

Galileo Was Wrong

**The Scientific, Scriptural, Ecclesiastical and Patristic
Evidence for Geocentrism**

**Volume I
The Scientific Evidence**

**Robert A. Sungenis, Ph.D.
and
Robert J. Bennett, Ph.D.**

Copyright: Robert A. Sungenis, Sr. and assigns

All rights reserved

No part of the contents of this Compact Disc version of the book titled *Galileo Was Wrong* is permitted to be reproduced or copied by any means whatsoever without written consent from the copyright holder, except for quotations to be used in various print or electronic mediums.

ISBN: 0-9779640-0-0

Cover Design and Production: Jason Corsetti

Many of the illustrations and photographs in *Galileo Was Wrong*, are copyrighted by Mark J. Wyatt or others (generally noted on images or headers), and used by permission for this publication.

Animations presented in the CD version of *Galileo Was Wrong* are copyrighted by Douglas Rudd, and are used by permission for this publication.

A galley copy of *Galileo Was Wrong* has been submitted to William Joseph Cardinal Levada, Prefect for the Congregation of the Doctrine of the Faith, to obtain an Imprimatur.

Galileo Was Wrong is published by:

Catholic Apologetics International Publishing
Post Office Box 278
State Line, Pennsylvania, 17263
www.galileowaswrong.com

Produced in the United States of America

This book is dedicated to:

St. Robert Cardinal Bellarmine

For his courage and foresight in standing up
to the unproven theories
of Galileo Galilei

Special Appreciation

Our thanks to the following individuals and institutions for helping in the content and publishing of this book:

A special thanks to Mark Wyatt for his insight and advice during the entire course of this project, and for the production of the photographs and charts.

A special thanks to Gerald Margand, Paul Melka and Kari Oppliger for their proof reading of this book.

A special thanks to Mario Dierksen for his translation of the German texts, and Fr. Brian Harrison, for his translation of the Italian texts. (The Hebrew, Greek and Latin texts were translated by Robert Sungenis).

A special thanks to Douglas Rudd for his production of the geocentric animations.

A special thanks to Jason Corsetti for the design and production of the book cover and CD cover.

A special thanks to Gerardus Bouw and Martin Selbrede for providing their expertise and consultations.

A special thanks to the Britons Catholic Library, Catholic University of America, Georgetown University, George Washington University and the Washington Theological Union.

About the Authors:

Robert A. Sungenis, Ph.D., is the president of Catholic Apologetics International. He holds advanced degrees in Theology and Religious Studies from Calamus International University, George Washington University and Westminster Theological Seminary. He also has an undergraduate emphasis in physics and general science. His dissertation: “Heliocentrism is an Unproven Scientific Hypothesis” serves as the primary source for the book *Galileo Was Wrong*. Robert is the author of several other books and many articles on religion, politics, science and culture including: *The Catholic Apologetics Study Bible, Vol. 2, The Apocalypse of St. John* (Queenship Publishing, 2006); *The Catholic Apologetics Study Bible, Vol. 1, The Gospel According to St. Matthew* (Queenship Publishing, 2003); *Not By Bread Alone: The Biblical and Historical Evidence for the Eucharistic Sacrifice* (Queenship Publishing, 2000); *How Can I Get to Heaven: The Bible’s Teaching on Salvation Made Easy to Understand* (Queenship Publishing, 1998); *Not By Faith Alone: The Biblical Evidence for the Catholic Doctrine of Justification* (Queenship Publishing, 1997); *Not By Scripture Alone: A Catholic Critique of the Protestant Doctrine of Sola Scriptura* (Queenship Publishing, 1997); *Shockwave 2000* (New Leaf Press, 1994). He also has appeared on radio and television, including programs on CNN and EWTN. Robert is the principal author of *Galileo Was Wrong*.

Robert J. Bennett, Ph.D., holds a doctorate in Physics from Stevens Institute of Technology and focused on general relativity in his dissertation on “Relativistic Rigid Body Motion.” He served as a physics instructor at Manhattan College and Bergen Community College from 1967-1983, and is presently doing private tutoring in physics and mathematics. In Chapter 12, Robert has written a detailed, technical and mathematical explanation for the various arguments for Geocentrism presented in Chapters 1-11. He has served as a consultant for the entire *Galileo Was Wrong* project.

Contents

Notes on Terminology	xiii
Introduction	1
Chapter 1	
The New Galileo and the Real Truth about Copernicanism	
Galileo's Conversion to Geocentrism	19
Copernicanism's Procrustean Bed	28
The Real Truth about Copernicus' Solar System	32
The Real Truth about Kepler's Solar System	55
What was the Attraction to Copernicanism?	62
Is There a Copernican Conspiracy?	69
The Demise of Modern Cosmology	79
Chapter 2	
Science and Its Problems	
Critical Remarks from its Own Ranks	94
The Guardians at the Gate of Knowledge	100
Is Modern Science Corrupt?	115
The Changing Tide	122
Strength and Weakness in the Catholic Hierarchy	124
Chapter 3	
Evidence of Geocentrism in the Cosmos	
The "Intolerable" Evidence of Geocentrism	136
Gamma-Ray Bursts: The Copernican Dilemma	156
Quasars: Spherical Shells around the Earth as Center	167
BLac and X-Ray Bursts: Earth-centered Periodicity	176
Galaxies: Spheres of Stars around the Earth as Center	178
Spectroscopic Binaries and Globular Clusters	185
Quantized Planetary Orbits	188
The Sloan Digital Sky Survey	190
A Few Words about the Discovery of the CMB	192

Chapter 4

Answering Common Objections

Doesn't the Smaller Revolve Around the Larger?	197
Doesn't Stellar Parallax Prove Heliocentrism?	200
Doesn't the Foucault Pendulum Prove Earth is Rotating?	203
Doesn't Retrograde Motion Prove Heliocentrism?	205
Doesn't NASA Use the Heliocentrism for Space Probes?	207
Don't the Phases of Venus Disprove Ptolemy?	210
Isn't it Impossible for the Stars to Travel so Fast?	214
Didn't Science Prove that Ether Doesn't Exist?	219
Isn't the Bible Merely Using Figurative Language?	224

Chapter 5

Albert Einstein and the Interferometers: The Frightening Possibility of a Motionless Earth

The "Unthinkable" Proposition	230
The Significance of the Michelson-Morley Experiment	236
Einstein's Concern for the Fizeau and Airy Experiments	237
The Experiments of Dominique Arago	241
The Experiments of Augustin Fresnel	242
The Experiments of Armand Fizeau	246
The Experiments of George Airy and James Bradley	249
The Experiments of Martinus Hoek, Eleuthère Mascart	253
The 1881 Michelson Experiment	258
The 1887 Michelson-Morley Experiment	261
The Fitzgerald/Lorentz Contraction Hypothesis	265
Albert Einstein Enters the Fray	283
Einstein Invents Special Relativity to Answer Michelson	295
Herbert Dingle's Critique of Einstein	303
Martin Gardner and the Inherent Flaws of Relativity	309
The Case of the μ -meson	312
Einstein Reinterprets Maxwell's Equations	318
Einstein Invents General Relativity	327
The Failure of General Relativity	334
The Maze of Relativity Theory	339

Chapter 6

What Did Michelson-Morley Actually Demonstrate?

What is at Stake?	347
Interferometer Experiments Subsequent to 1905	351
What does this mean for Geocentrism?	355
What About the Copernican Non-Relativists?	356
Correctly Interpreting the Interferometers	358
Georges Sagnac: Rediscovery of Absolute Motion	361
The Michelson-Gale Experiment	369
The Dayton Miller Experiments	373
Recent Ether-Drift Experiments	389

Chapter 7

What is Space?

The Philosophical Problem of Extension and Divisibility	395
Einstein's Ether	400
More Concrete Candidates for Material Ether	411
The Ether of Quantum Mechanics and String Theory	421
String Theory: Seeking to Bridge Einstein and Quantum	429
Can Man Live in the World he has Created?	433
The Copenhagen Perspective	436
The Demise of Relativity Theory	441
Newton's Absolute Space and Spinning Water Bucket	446
The "Space" of Diggs, Bruno, and Descartes	449
The "Space" of Leibniz, Euler, and Kant	452
Ernst Mach, Albert Einstein and Modern Philosophy	453
Mach's Interpretation of Newton's Bucket	459
Einstein's Interpretation of Newton's Bucket	462
The Inherent Problems of Newton and Einstein's Physics	467
Are There Universal Connections in Space?	470
The Geocentric Connection	477

Chapter 8

The Physical Cause of Gravity

The Theories of Isaac Newton	487
The Theories of De Duiller and Le Sage	491
The Problems with General Relativity's Gravity	494
"Dark" Problems for Modern Notions of Gravity	503
The Physical Cause of Gravity	512

Chapter 9

How Old and How Big is the Universe?

Modern Science and Atheistic Philosophy	519
The Influence of Isaac Newton	524
The Influence of Immanuel Kant	532
Infinite Problems with an Infinite Universe	535
Olbers' Paradox	535
Gravity's Paradox	538
Einstein's Fudge Factor: The Cosmological Constant	539
Edwin Hubble and Cosmology's Wax Nose	543
The Proposed Solutions of Lemaître, Eddington, et al.	557
The Galaxy Formation Problem	561
George Gamow and the Birth of the Big Bang	565
The Anit-Big Bang Movement	568
Redshift and the New Alternative	571
The Use and Abuse of Stellar Parallax	576

Chapter 10

Mathematical Models of a Geocentric Universe

Geostatism and Geocentrism	590
Absolute Rest versus Relative Motion	591
Fred Hoyle's Geocentrism	594
The Gyroscopic Effect on Earth	599
Einstein's Geocentrism	607
Thirring's Geocentrism	611
Rosser's Geocentrism	616
Bondi's Geocentrism	619
Brill and Cohen's Geocentrism	623
Moon and Spencer's Geocentrism	623
Møller's Geocentrism	624
Brown's Geocentrism	625
Nightingale's Geocentrism	625
Lynden-Bell's Geocentrism	626
Barbour and Bertotti's Geocentrism	628
Fred Hoyle's Problem's with Earth's Diurnal Motion	631

Chapter 11

Hildegardian Geocentrism:

Aristotelian Cosmology Meets Modern Science

A Brief History of Hildegard's Life	638
Earth: The Center of Six Cosmic Layers	642
Water in the Remote Recesses of Outer Space	644
Scriptural Accounts of Primordial Water and Plasma	647

The Sequence of Events from the First to Fourth Day	651
The Outer Layer of Plasma and Modern Science	653
Purpose of the CMB's 2.73° Kelvin Temperature	656
The Four Elements of the Universe	657
The Rotation of the Firmament	661
The Local Cosmic Counter-Current	664
The Force that Moves the Planets	667
The Cause of the Four Seasons	668
The Universe Flips Over	669
Behavior of Man and the Reaction of the Cosmos	671
The Constitution of the Firmament	673
Hildegard and the Cause of Gravity	681
The Physical Cause of Gravity	685
The Twelve Cosmic Winds	687
The Sixteen Controlling Stars	689
The Effects of the Cosmos upon Earth	691
Energy Supplied to the Sun	694
Mathematical Constants in the Geosystem	694
No Ellipses for the Solar Movements	696

Chapter 12

Technical and Summary Analysis of Geocentric Cosmology

Part 1: Does the Earth Rotate? 710

The Opposing Formal Proof	713
Physical Constituents of a Geocentric Universe	715
The Sagnac Effect: Claims and Responses	730
Michelson-Gale: Claims and Responses	745
Hefele-Keating: Claims and Responses	748
Global Positioning System: Claims and Responses	760
Ives-Stilwell: Claims and Responses	783
Atmospheric Circulation is Anti-Geokinetic	787

Part 2: Does the Earth Revolve Around the Sun? 791

Parallax vrs. Aberration: Claims and Responses	792
Binary Stars: Claims and Responses	823
Faraday Rotor Generator: Claims and Responses	831
More on Parallax	833
The 1887 Michelson-Morley Experiment	842
The Oliver Lodge Experiment	854
The Trouton-Noble Experiment	855
The Trouton-Rankine Experiment	856
The Kennedy-Thorndike Experiment	858

The Hamar Experiment	859
The Frisch-Smith Experiment	859
The DePalma Spinning Ball Drop	861
Tiff't's Quantum Redshifts: Claims and Responses	862
Superluminal Motion: Claims and Responses	867
Binary Star Precession	868
The Aspden Effect	869
Marinov's Self-Accelerating Plasma Tube	871
The Casimir Force	872
Magnetic Memory	873
Wang Superluminality	874
The Holger Müller Experiment	875
Quasars in Galaxies	877
Redshift Surveys: Claims and Responses	878
Gamma Ray Bursts	880
Gravitomagnetic London Moment	885
Part 3: Does the Solar System Move Through Space?	886
Interferometers: Dayton Miller	887
Michelson-Morley versus Miller	896
Einstein versus Miller	898
Cosmic Ether Drift	898
Maurice Allais Analysis	900
Illingworth, Joos: Claims and Responses	901
The Jaseja Experiment	905
Spinning Mössbauer Effect	906
Shapiro Venus Radar	910
The Brilliet-Hall Experiment	913
The Torr-Kolen Experiment	914
Silvertooth Experiment: Claims and Responses	916
The DeWitte Experiment	917
CMB Dipole Evidence: Claims and Responses	920
Nodland-Ralston Evidence: Claims and Responses	928
Tegmark's CMB Quadrupole-Octopole	932
The Galaev Evidence	941
More on the Miller Interferometer Experiments	947
The Pioneer Anomalies: Claims and Responses	949
Conclusion	959

Appendices:

Appendix 1: Anomalies Concerning the Speed of Light	960
Appendix 2: The Stars and the Speed of Light in Genesis 1	970
Appendix 3: The Origin of the Equation $E = mc^2$	978
Appendix 4: Do the 1919 Eclipse Photographs Prove General Relativity?	984
Appendix 5: Does Mercury's Residual Perihelion Prove General Relativity?	999
Appendix 6: Does the Hafele-Keating Experiment Prove General Relativity?	1018
Appendix 7: Do the Global Positioning Satellites Prove General Relativity?	1025
Appendix 8: The De Broglie Wavelength	1035
Appendix 9: The Personal Lives of: Copernicus, Kepler, Galileo, Newton, Einstein	1039
Bibliography	1073

Notes Regarding terminology:

This book is written for both layman and scientist. The main text of the book seeks to explain the scientific information in a simple and entertaining way. The footnotes contain the technical information and sources for the scientist and scholar.

Regarding terminology, for simplicity's sake *Galileo Was Wrong* employs the term "geocentrism" to represent the scientific position which holds that the Earth is motionless in space at the center of the universe with neither diurnal rotation on its axis nor translational movement around the sun. For sake of the same simplicity, we have adopted the term "heliocentrism" to represent the views of Copernicus, Galileo, Kepler, Newton and Einstein, even though there are various differences among them.

Some geocentrists employ the terms "geocentricity" or "geostatism" to represent the motionless Earth, and employ "geokineticism" or "antigeostatism" to represent a moving Earth. Although these are good terms in their own right, we have opted not to use them due to the popularity of the terms "geocentrism" and "heliocentrism." The term "geocentrism" will stand for any scientific theory that holds the Earth is either the center of the universe or motionless in space. The term "heliocentrism" will stand for any scientific theory that holds that the Earth is not in the center, or that the sun is the center, or that there is no center of the universe, and that the Earth is in constant motion in the universe.

In addition to the above, we have adopted the spelling "ether" rather than "aether," since most scientific texts have employed the former. For the most part, all the spellings of words have retained the reference's original spelling, especially when quotes are made from British sources. We have also adopted to capitalize titles such as Special Relativity, General Relativity, Quantum Mechanics, the Big Bang, String Theory, etc., in order to emphasize that a particular but controversial theory is being discussed. The word "Earth" has been consistently capitalized in distinction to "sun," "moon," "stars" or "universe" which have been left in the lower case. The cosmic microwave background radiation is abbreviated with the acronym "CMB."

So as to limit the confusion often inherent in the words rotation and revolution, *Galileo Was Wrong* uses the word "rotation" to refer to the turning of an object upon its own axis, including the turn of the entire universe around the north-south axis of the Earth; whereas "revolution" refers to the angular movement of one object around another object wherein both objects are separated by space, as in saying "the planet Mercury revolves around the sun."

Galileo Was Wrong will sometimes repeat concepts or quotes from various authors in different parts of the book when appropriate.

Introduction

Galileo Was Wrong will, at the least, be viewed as an unusual book by the world at large. In modern times, everyone is taught from early childhood through old age that the Earth rotates on its axis and revolves around the sun. It is considered a bedrock of truth so firmly established that only the most daring of skeptics would doubt or question it. Unbeknownst to most people, however, is the fact that no one in all of history has ever *proven* that the Earth moves in space, much less rotates or revolves. As one honest scientist put it in a book endorsed by Albert Einstein: "...nor has any physical experiment ever proved that the Earth actually is in motion."¹ The evidence shows that heliocentrism is merely the *preferred* model of cosmology for modern science. Although various scientists and historians have certainly made it *appear* as if many and varied proofs exist for heliocentrism, and thereby they have convinced a rather naïve public, in reality, modern science is actually covering up the fact that it has no proof for its cherished view of cosmology. As [Einstein](#) himself once admitted, dependence today on the doctrine of Copernicus is little more than wishful thinking:

Since the time of Copernicus we have known that the Earth rotates on its axis and moves around the sun. Even this simple idea, so clear to everyone, was not left untouched by the advance of science. But let us leave this question for the time being and accept Copernicus' point of view.²

Modern science has, indeed, been very happy to follow Einstein's prescription. Although the theory of Relativity, by its very nature, at best brings Copernican cosmology under great suspicion and ultimately forces it into becoming just one perspective among others, these implications have been ignored, and subsequently the science community has decided to "leave this question for the time being and accept Copernicus' point of view," hoping that few people will be bold enough to follow the implications to their logical conclusion and ask the all important questions. It is just a matter of time, however, before books and articles like the one you are reading will begin to reveal this information to the public. Up until now almost all of it has been hidden from their eyes. Little is revealed at the university level, and virtually none of it has been divulged in the secondary curriculum, and we certainly haven't read it on the pages of *Time* or *USA Today*, except

¹ Lincoln Barnett, *The Universe and Dr. Einstein*, New York, New American Library, 2nd revised edition, 1957, p. 73.

² Albert Einstein and Leopold Infeld, *The Evolution of Physics*, New York, Simon and Shuster, 1938, 1966, pp. 154-155.

perhaps for the occasional ridiculing of “fundamentalists” and their offshoots for even broaching such subjects. There is a good reason why such reticence exists – there is simply too much at stake. The mere thought of having to tell the world that it might have to turn back the clock and admit that science took a wrong turn when it accepted the Copernican theory as a scientific fact is, as Einstein’s biographer once put it, “unthinkable.”³

We can, however, sympathize with their plight. One can imagine the sheer embarrassment modern science would face if it were forced to apologize for 500 years of propagating one of the biggest blunders since the dawn of time. This is not the Middle Ages, a time in which mistakes can be excused due to primitive scientific tools and superstitious notions. This is the era of Newton, Maxwell, Faraday, Darwin, Einstein, Edison, Planck, Hubble, Hawking, and scores of other heroes of science. If heliocentrism is wrong, how could modern science ever face the world again? How could it ever hold to the legacy left by these scientific giants if it were forced to admit it was wrong about one of its most sacrosanct and fundamental beliefs? Admitting such a possibility would put question marks around every discovery, every theory, every scientific career, every university curriculum. The very foundations of modern life would crumble before their eyes. Not only would Earth literally become immobile, but it would figuratively come to a halt as well, for men would be required to revamp their whole view of the universe, and consider the most frightening reality of all – that a supreme Creator actually *did* put our tiny globe in the most prestigious place in the universe, since only fools would dare to conclude that Earth could occupy the center of the universe by chance. Most of all, science would be compelled to hand the reins of power and influence back to the Church and to Scripture, since it is from these sources alone that the teaching of a motionless Earth never succumbed.

In order to reveal the full details behind this story, *Galileo Was Wrong* will not only critique the belief that the Earth revolves around the sun, it will also uncover the many misleading hypotheses from science and philosophy that led us there, and which continue to lead the world into various and sundry fallacies about the cosmos and life in general. This will require a critique of all the major players in cosmology, including Copernicus, Galileo, Kepler, Newton, Einstein, Hubble, Sagan, Hawking and many more. What we will find is, although we can all agree that modern science certainly has more sophisticated instruments today that allows it to gather thousands of bits of data about the universe, the problem is that scientists are at a loss how to interpret that information correctly and put it into a coherent and comprehensive understanding of the universe. Knowledge is plentiful, but wisdom is severely lacking. As one astronomer admitted: “Perhaps it is time for

³ Ronald W. Clark, *Einstein: The Life and Times*, New York, Avon Books, Harper Collins, 1984, p. 110.

astronomers to pause and wonder whether they know too much and understand too little.”⁴

The Church Confronts Galileo

The ecclesiastical side of the issue is also significant. In 1615, 1616, 1633 and 1664 the Catholic Church issued various formal and informal judgments against the Copernican theory, and especially against its main purveyor, [Galileo Galilei](#). One of the early warnings appeared on April 12, 1615 when [Robert Cardinal Bellarmine](#) wrote a personal letter to Paolo Antonio Foscarini who had been advocating the heliocentric view for some time. In the letter Bellarmine states:

Second, I say that, as you know, the Council prohibits interpreting Scripture against the common consensus of the Holy Fathers; and if Your Reverence wants to read not only the Holy Fathers, but also the modern commentaries on Genesis, the Psalms, Ecclesiastes, and Joshua, you will find all agreeing in the literal interpretation that the sun is in heaven and turns around the earth with great speed, and that the earth is very far from heaven and sits motionless at the center of the world. Consider now, with your sense of prudence, whether the Church can tolerate giving Scripture a meaning contrary to the Holy Fathers and to all the Greek and Latin commentators.

With Foscarini as the target, on February 24, 1616 an ecclesiastical commission of eleven clerics (most of them cardinals) under the direction of Cardinal Bellarmine, condemned Copernicanism as “formally heretical” and a cosmology that “contradicts the express wording of Scripture in many places.”⁵ Since Foscarini had already

⁴ Herbert Friedman, *The Amazing Universe*, National Geographic Society, 1975, p. 180.

⁵ Original Latin: “Prima: Sol est centrum mundi, et omnino immobilis motu locali” (Translation: “First: The sun is in the center of the world, and is completely immobile in its location”). “Censura: Omnes dixerunt, dictum propositionem esse stultam et absurdam in philosophia, et formaliter haeticam, quatenus contradicit expresse sentiis Sacrae Scripturae in multis locis secundum proprietatem verborum et secundum communem expositionem et sensum Sanctorum Patrum et theologorum doctorum” (Translation: “Censored: We declare, the stated proposition is foolish and absurd in philosophy, and formally heretical, inasmuch as it contradicts the express wording of Sacred Scripture in many places, according to the meaning of the words and the common interpretation and sense of the Fathers and the doctors of theology”). “2. Terra non est centrum mundi nec immobilis, sed secundum se totam movetur, etiam motu diurno” (Translation: “The Earth is not the center of the universe nor immobile, but is itself completely moved, and also moves diurnally”). “Censura: Omnes dixerunt, hanc propositionem recipere eandem censuram in philosophia; et spectando veritatem theologicam, ad minus esse in Fide erroneam” (Translation: “We declare, this proposition receives the same censure in philosophy, and in regard to its theological truth, it at least is erroneous in Faith”). (Antonio Favaro, *Galileo e l’Inquisizione*,

published his book, it could not be corrected; and thus the Church's only choice was to condemn the book and its contents.⁶ As regards Galileo, on February 26, 1616, [Pope Paul V](#) ordered Cardinal Bellarmine to summon him to Rome and, "in the presence of a notary and witnesses lest he should prove recusant, warn him to abandon the condemned opinion and in every way abstain from teaching, defending or discussing it."⁷ This was followed by a formal decree issued by the *Sacred Congregation of Cardinals under Pope Paul V, Authorized by the Apostolic Chair to the Index of Forbidden Books* on March 5, 1616 containing six explicit paragraphs reiterating the condemnation not only of the book written by "[Nicolaus Copernicus](#)" but, more deeply, the original Greek inventors of heliocentrism as represented by "the false doctrine of Pythagorus, concerning the mobility of the Earth and the immobility of the sun, as completely adversarial to the divine Scriptures."⁸ In the midst of these events, Galileo wrote to Cardinal Bellarmine in May 1616 asking for a clarification of what occurred in the March 1616 session, prompting Bellarmine to write a certificate for Galileo saying that, at that specific time, he was neither forced to renounce his opinions nor punished for them, but that he was:

...informed of the declaration made by his Holiness and published by the Sacred Congregation of the Index, in which it is stated that the doctrine attributed to Copernicus – that the

Documenti de Processo Galileiano...per la prima volta integralmente pubicati, Florence, 1907, p. 61).

⁶ Foscarini published his work in Naples in 1615, titled: *Lettera Sopra L'Opinione de' Pittagorici e del Copernico, della Mobilita della Terra e Stabilita del Sole, e il Nuovo Pittagorico Sistema del Mondo*.

⁷ Dorothy Stimson, *The Gradual Acceptance of the Copernican Theory of the Universe*, New York, Baker and Taylor, 1917, p. 58. Favaro has the following: "...supradictus P. Commissarius praedicto Galileo adhuc ibidem praesenti et constituto praecepit et ordinavit [proprio nomine] S. D. N. Papae et totius Congregationis S. Officii, ut supradictam opinionem, quod sol sit centrum mundi et imbolilis et terra moveatur, omnino relinquat, nec eam de caetero, quovis modo, teneat, doceat aut defendat, verbo aut scriptis; alias, contra ipsum procedetur in S. Officio. Cui praecepto idem Galileus aquievit et parere promisit" (Antonio Favaro, *Galileo e l'Inquisizione, Documenti de Processo Galileiano...per la prima volta integralmente pubicati*, Florence, 1907, p. 62).

⁸ "Decretum: Sacrae Congregationis Illustrissimorum S.R.E. Cardinalium, a S.D.N. Paulo Papa V Sanctaque Sede Apostolica ad Indicem librorum...falsam illam doctrinam Pithagoricam, divinaeque Scriptureae omnino adversantem, de mobilitate terrae et immobilitate solis, quam Nicolaus Copernicus De revolutionibus orbium coelestium..." Added to the condemnation were: "Didacus Astunica," "Padre Maestro Paolo Antonio Foscarini Carmelitano" and "Lazzaro Scoriggio" in the most explicit and repetitive language condemning any advocacy of the immobility of the sun and the mobility of the Earth (Antonio Favaro, *Galileo e l'Inquisizione, Documenti de Processo Galileiano...per la prima volta integralmente pubicati*, Florence, 1907, pp. 62-63).

earth moves around the sun and that the sun stands in the center of the world without moving from the east to the west – is contrary to the Holy Scriptures and therefore cannot be defended nor held.⁹

The letter from Bellarmine would prove to be an important document, since it later served as evidence against Galileo seventeen years later in 1633 when [Pope Urban VIII](#) reminded him that he was under strict orders not to teach the heliocentric system, which decree Galileo had broken many times since 1616. In April 1633, the pope thus forced Galileo to renounce his views and write a detailed abjuration.¹⁰ Urban then sent a formal letter to the inquisitors and papal nuncios of Europe announcing Galileo's abjuration and requiring them to heed the Vatican's condemnation of Copernicanism.¹¹ Thirty-one years later, in 1664, [Pope Alexander VII](#) attached condemnations of the works of Copernicus, Galileo, and Kepler to a papal bull appropriately titled *Speculatores domus Israel* ("Spies in the House of Israel"), signed by the pope himself.¹²

Despite these official ecclesiastical injunctions against Copernicanism, the sun-centered theory slowly but surely became the settled thinking of modern man. Perhaps wishing to reassess the Church's prior condemnation of heliocentrism, in 1979, [Pope John Paul II](#) set up an

⁹ Original Italian: "...ma solo gl'è stata denunciata la dichiarazione fatta da Nostro Signore et publicata dalla Sacra Congregatione dell' Indice, nella quale si contiene che la dottrina attribuita al Copernico, che la terra si muova intorno al sole et che il sole stia nel centro del mondo senza muoversi da oriente ad occidente, sia contraria alle Sacre Scritture, et però non si possa difendere nè tenere" signed by Bellarmine on May 26, 1616 (Antonio Favaro, *Galileo e l'Inquisizione, Documenti de Processo Galileiano...per la prima volta integralmente publicati*, Florence, 1907, pp. 82, 88).

¹⁰ Antonio Favaro, *Galileo e l'Inquisizione, Documenti de Processo Galileiano...per la prima volta integralmente publicati*, Florence, 1907, pp. 76-85; 142-151.

¹¹ Dorothy Stimson, *The Gradual Acceptance of the Copernican Theory of the Universe*, New York, Baker and Taylor, 1917, p. 59

¹² *Index Librorum Prohibitorum et Expurgandorum Novissimus, Pro Catholicis Hispaniarum*, Regnis Philippi IV, Regis Cathol., Ill., AC. R. D.D. Antonii A Sotomaior O.P., Supremi Præfidis, & in Regnis Hispaniarum, Siciliae, & Indiarum Generalis Inquifitoris, c. juffu ac ftudiis, luculenter & vigilantiffimè recognitus, Madriti [Madrid], Ex Typographæo Didaci Diaz, Subfignatum Lldo Huerta, M. DC. LXXVII [1667]. "*Index Librorum Prohibitorum*, Alexandri Septimi [Alexander VII] Pontificis Maximi juffu editus: Copernicanæ Aftronomiæ Epitome. vide, Ioannis Kepleri; Copernicus. vide, Nicolaus." (p. 30); "Galileo Galilei. Vide, Dialogo di Galileo." (p. 52); "Ioannis Keppleti Epitome Aftronomiæ Copernicanæ" (p. 73), attached to: "...Bullam Alexandri VII, P. M. qualis est in limine Editionis Superioris Anni, qui est M, DC, LXIV [1664]. Nam licèt nonnulla contineat, quæ ad illam Editionem, ejusque dispositionem speciatim pertinent, non sufficiebat tamen ea ratio, vt ejus lectione non fruerentur hic Fideles. Alexander Papa VII, Ad perpetua rei Memoriam. Speculatores Domus Israel..." (p. 137).

ecclesiastical commission to reinvestigate the Galileo affair. After receiving the commission's results in 1981, eleven years later the pope gave a short speech on the matter to the Pontifical Academy of Science in 1992. Overall, the speech seeks to strike a balance between both sides of the issue. On the one hand, John Paul II seems to echo the position we quoted earlier from Albert Einstein:

...an absolute physical reference point...in the Earth or in the sun....Today, after Einstein and within the perspective of contemporary cosmology neither of these two reference points has the importance they once had.¹³

Perhaps desiring to give some credence to both the heliocentric and geocentric cosmologies, the pope adds that because of

...the problem of the emergence of complexity in mathematics, physics, chemistry and biology...indicates precisely that, in order to account for the rich variety of reality, we must have recourse to a number of different models.

On the other hand, although John Paul II never directly concedes that heliocentrism is correct, some might conclude that he implies as much.¹⁴ At this point he takes the opportunity to say that the Church must coincide her beliefs with the truths of science:

By virtue of her own mission, the Church has the duty to be attentive to the pastoral consequences of her teaching. Before all else, let it be clear that this teaching must correspond to the truth. But it is a question of knowing how to judge a new scientific datum when it seems to contradict the truths of faith. The pastoral judgment which the Copernican theory required

¹³ John Paul II, address to the Pontifical Academy of Science, November 4, 1992, paragraph 11.

¹⁴ The same type of concession without admission is noted in his September 22, 1989 remarks at Pisa: "How can one not recall at least the name of that great man, who was born here and from here took the first steps towards an imperishable fame? I speak of Galileo Galilei, whose scientific works, unfortunately obstructed at first, are now recognized by all as an essential stage in the methodology and, in general, on the journey towards the world's knowledge of nature" (*L'Osservatore Romano*, October 10, 1989). Here the pope says only that Galileo was "an essential stage in the methodology," and that his work was merely part of "the journey towards the world's knowledge of nature," not that heliocentrism is a proven fact of science. In fact, with regards to the pope's suggestion that this is a "journey," one could say that the errors modern science has subsequently discovered in Galileo's non-elliptical model forces us to look even closer at the merits of the Ptolemaic and Tychonian geocentric models.

was difficult to make, in so far as geocentrism seemed to be a part of scriptural teaching itself.¹⁵

In similar fashion, he seems to distance himself and the modern Church from the Church of the seventeenth century by such statements as:

The majority of theologians did not recognize the formal distinction between Sacred Scripture and its interpretation, and this led them unduly to transpose into the realm of the doctrine of the faith a question which in fact pertained to scientific investigation...[Cardinal Poupard](#) has also reminded us that the sentence of 1633 was not irreformable...The error of the theologians of the time, when they maintained the centrality of the Earth, was to think that our understanding of the physical world's structure was, in some way, imposed by the literal sense of Sacred Scripture.¹⁶

But whatever the implications of the above statement for the favoring of heliocentrism, they are as quickly neutralized if one important fact is never forgotten: once it is posited that the former “theologians” of the Catholic Church made a “pastoral error” by refusing to listen to science and by insisting on a literal interpretation of Scripture, this assessment, by force of logic, leaves modern theologians of the Catholic Church open to the same error and stubbornness. That is, they themselves may be refusing to listen to the scientific evidence against their view, and, consequently, they may be giving the wrong “pastoral” advice to their flock by erroneously promoting a non-literal interpretation of Scripture.

This is the inevitable trap Church officials create when they question or reject previous high-level decisions in the ecclesiastical Tradition, for no one can deny this simple logic: if the “theologians” of the past can err, then the theologians of the present can err. It is inevitable that if the modern Church doubts or questions the traditional Church's prior rejection of Copernicanism, the modern Church calls into question its own ability to judge the issue correctly. The modern Church is, in an ironic way, ‘hoist by its own petard,’¹⁷ for if the Holy Spirit, who does not lie, was not guiding the three aforementioned popes and

¹⁵ John Paul II, address to the Pontifical Academy of Science, November 4, 1992, paragraph 7.

¹⁶ John Paul II, address to the Pontifical Academy of Science, November 4, 1992, paragraphs 9, 12.

¹⁷ The expression “hoist by one's own petard” first appeared in Shakespeare's play, *Hamlet*, meaning “to blow oneself up with one's own bomb, be undone by one's own devices.”

their Sacred Congregations during the inquisition of Galileo on an issue of such great pastoral importance (not to mention the Church Fathers and their medieval successors who, based on their consensus of the proper interpretation of Scripture, were all geocentrists), how can they be sure the Holy Spirit is guiding the present pastors of the Church? The intractable nature of this problem is reinforced by the fact that, according to the modern Church, neither the seventeenth century papal sanction of the condemnation of Copernicanism, namely, that it was “opposed to Scripture,” nor the twentieth century papal speech that “theologians did not recognize the formal distinction between Sacred Scripture and its interpretation,” are “irreformable.”

What is the way out of this dilemma? The answer is to apply John Paul II’s words to his own requirements for discerning truth. He writes in the same document:

It is a duty for theologians to keep themselves regularly informed of scientific advances in order to examine...whether or not there are reasons for taking them into account in their reflection or for introducing changes in their teaching.¹⁸

Keeping “regularly informed of scientific advances” so that theologians can “introduce changes in their teaching” is precisely what this book, *Galileo Was Wrong*, will encourage modern “theologians” to do. When they see that there is no scientific proof for heliocentrism, and that geocentrism has much more scientific credibility than previously reported, they will, as John Paul II predicted, have enough information to “introduce changes in their teaching” as they consider the facts of science in a whole new way, leading, hopefully, to a moratorium on apologizing for the popes and cardinals of the seventeenth century and, in turn, giving them the respect they are due as stewards of the Gospel. Once an honest, studious and open-minded analysis is made of the scientific evidence, we will see that the Holy Spirit was, indeed, guiding the Church of yesteryear to censor Copernicanism and, in turn, insisting that we take Scripture’s propositions at face value. Without scientific proof for heliocentrism, today’s Church is under no obligation to entertain it as more than a curious hypothesis, and, consequently, she is neither under divine compulsion nor can she claim any justifiable reason to abandon the literal interpretation of Scripture. **As St. Augustine once said:**

*But if they are able to establish their doctrine with proofs that cannot be denied, we must show that this statement of Scripture...is not opposed to the truth of their conclusions.*¹⁹

¹⁸ John Paul II, address to the Pontifical Academy of Science, November 4, 1992, paragraph 8.

¹⁹ *The Literal Interpretation of Genesis* Book 2, Chapter 9, paragraph 21.

Suffice it to say, modern science has never provided the world with “proofs that cannot be denied” to back up its steadfast devotion to heliocentrism. In that light, [Pope Leo XIII](#) made Augustine’s teaching concerning the interpretation of Scripture into Catholic doctrine, following the Tradition of the Church:

But he must not on that account consider that it is forbidden, when just cause exists, to push inquiry and exposition beyond what the Fathers have done; provided he carefully observes the rule so wisely laid down by St. Augustine – not to depart from the literal and obvious sense, except only where reason makes it untenable or necessity require.²⁰

Simply put, without scientific proof for heliocentrism, there is no “reason” or “necessity” to “depart from the literal and obvious sense” of Scripture. As physicist Henri Poincaré put it: “We do not have and cannot have any means of discovering whether or not we are carried along in a uniform motion of translation.”²¹ Einstein thus concluded:

Either coordinate system could be used with equal justification. The two sentences: “the sun is at rest and the Earth moves,” or “the sun moves and the Earth is at rest,” would simply mean two different conventions concerning two different coordinate systems.”²²

In an ironic sort of way, is not Einstein’s statement about the essential equality of differing “coordinate systems” remarkably similar to what Robert Cardinal Bellarmine told Paolo Antonio Foscarini when the latter insisted upon forcing the heliocentric system on the world? Being the astute intellectual he was, Bellarmine, like Einstein, easily saw how mathematics could save the appearances of either system, and thus his following words to Foscarini have echoed through the halls of relativistic science as no others from the sixteenth century. But, going beyond

²⁰ Encyclical letter of 1893, *Providentissimus Deus*. The “Fathers,” as we will see in Volume II of this series, were all avowed geocentrists in the face of many of the Greek philosophers and astronomers who were espousing heliocentrism.

²¹ Poincaré’s lecture titled: “L’état actuel et l’avenir de la physique mathématique,” St. Louis, Sept. 24, 1904, *Scientific Monthly*, April, 1956.

²² *The Evolution of Physics: From Early Concepts to Relativity and Quanta*, Albert Einstein and Leopold Infeld, New York, Simon and Schuster, 1938, 1966, p. 212. As Fred Hoyle notes: “...according to the physical theory developed by Albert Einstein [the heliocentric and geocentric systems] are indeed physically equivalent to each other” (*Astronomy and Cosmology*, p. 8).

relativity, he also knew that, for higher reasons, only one system could be the correct one. Thus, to Foscarini he writes:

First. I say that it seems to me that Your Reverence and Galileo did prudently to content yourself with speaking hypothetically, and not absolutely, as I have always believed that Copernicus spoke. For to say that, assuming the earth moves and the sun stands still, all the appearances are saved better than with eccentrics and epicycles, is to speak well; there is no danger in this, and it is sufficient for mathematicians. But to want to affirm that the sun really is fixed in the center of the heavens and only revolves around itself without traveling from east to west, and that the earth is situated in the third sphere and revolves with great speed around the sun, is a very dangerous thing, not only by irritating all the philosophers and scholastic theologians, but also by injuring our holy faith and rendering the Holy Scriptures false.

As we will see in the following pages, the evidence is so revealing that, in consideration of the fact that modern science has admitted both that it cannot prove heliocentrism and that geocentrism is not only a perfectly viable model of the universe but in many respects it is the more logical answer to the scientific data, it is the world who now owes an apology to the Catholic Church.

Scripture is Not a Science Book

As someone once said, and we agree, “Scripture is not a science book.” But that truth, unfortunately, has been badly misrepresented and invariably used to silence theologians who seek to extract at least some truth from Scripture with which to build an understanding of the universe. Although Scripture does not reach the level of a science book, that does not mean that it cannot, or does not, speak about scientific issues on various occasions. The difference is subtle, but it is very important. For example, we can all agree that the *Declaration of Independence* and the *United States Constitution* are not religious documents. Most see them as political documents. But every American will agree that when either of them address a matter of religion, such as when the Declaration says: “We hold these truths to be self-evident, that all men are created equal, that they are endowed by their Creator with certain unalienable Rights, that among these are Life, Liberty and the pursuit of Happiness,” all ears stop to listen, since everyone acknowledges that the *Declaration* is giving factual and authoritative statements about religion that form the basis of the country’s foundation of government. The *Declaration* is certainly not a religious treatise, but it is, nevertheless, addressing an important area of religion in this particular instance, and it holds the same authority here as it does when it speaks about political and governmental issues.

In the same way, although Scripture is not a science book and does not employ formulas such as $E = mc^2$ or $F = ma$, nevertheless, when it touches upon an area of science, men need to listen, for it is giving factual and authoritative statements that form the basis of our cosmogony and cosmology. Discovering the scientific formulas that coincide with those foundational truths has been assigned to man's labor under the six days God has given him to work by the sweat of his brow, and as such, man's science can safely supplement divine revelation. Revelation does not seek to impinge upon man's freedoms and intellectual pursuits, but only to save him from the heartache and frustration of proceeding down the wrong scientific path, especially in areas regarding the creation of the world that no human being was present to witness, or with the structure of the cosmos from which no man has a high enough platform to determine which bodies are moving and which are not. As [Pope St. Pius X](#) once wrote:

Human science gains greatly from revelation, for the latter opens out new horizons and makes known sooner other truths of the natural order, and because it opens the true road to investigation and keeps it safe from errors of application and of method. Thus does the lighthouse show many things they otherwise would not see, while it points out the rocks on which the vessel would suffer shipwreck.²³

Accordingly, God drops small and precious rose petals of knowledge down from heaven to guide man in the paths of truth about the cosmos. It is only when we ignore this sweet-smelling flora that we soon go off into the myriad of conflicting theories man has concocted since the time of Copernicus, and which, as we will show, are unfortunately being added to the unhealthy diet of modern science on a daily basis.

Overview

With these facts in the background, the first volume of *Galileo Was Wrong* will be devoted mainly to the scientific evidence concerning cosmology. Since modern science has made itself into such an imposing authority on the minds of men today, no study of this kind could possibly be adequate until the scientific assertions are thoroughly addressed and rebutted. We believe we have compiled the most comprehensive and detailed scientific treatise on the issue of heliocentric versus geocentric cosmology ever offered to the public.

In addition to the information supporting a geocentric universe, we have also addressed related issues, such as: the physical cause of gravity and inertia; the flaws and fallacies in the theories of Special and General Relativity, the Big Bang, Quantum Mechanics, String Theory,

²³ Pope Pius X, encyclical of March 12, 1904, *Iucunda Sane*, 35.

the Newtonian formulas concerning force and gravity, and the modern interpretation of Maxwell's equations. We will examine all the interferometer experiments of the late 1800s and early 1900s; the electron/positron relationship; the phenomenon of entanglement; the reason for the 2.73° Kelvin temperature; the reason for the solar day and the sidereal day; the nature of the light of Genesis 1:3; the speed of light and the creation of the stars in Genesis 1:16; the components of the firmament and the water above it in Genesis 1:6-9; the scientific problems for a diurnally moving Earth; the corruption in modern science; the relationship between theology, philosophy and science; the personal lives of well-known scientists, and many more scientific issues related to cosmology and cosmogony.

The second volume of *Galileo Was Wrong* will be devoted mainly to the scriptural, ecclesiastical and patristic evidence supporting the cosmology of geocentrism. The decision was made to treat these three theological aspects in the second volume rather than the first since we believe that unless the scientific prejudices that led to adopting heliocentrism are adequately answered by science itself, there will be little room left to convince skeptics and non-believers of the theological side of the debate. We believe the first volume will adequately show that, with regard to heliocentrism, the greatest opponent of science is science itself.

But whether it is the first volume or the second, we only ask that you, the reader, contemplate the issue with an open mind. All too often when controversial subjects of this nature arise, those who wish to protect the *status quo* are quick to demonize their opponents, choosing instead to associate them with such institutions as the "Flat-earth society," or characterize them as geeks who don tin foil hats and receive messages from outer space. Hopefully, you will not fall into that trap of bigotry and censorship. Rest assured, the authors of this book do not identify with any of the above caricatures, but are dedicated solely to the cause of truth, both scientific and theological, and will seek to do their task in the face of any criticism.

We encourage everyone to consider the merits of geocentric cosmology not merely for the sake of truth and scientific knowledge, but mainly because we insist that the world will be a better place to live once this foundational view of the universe seeps back into the psyche of modern man. The world today has lost sight of its purpose for existence. Corruption, apathy and decadence have penetrated almost every level of society. Consequently, the human soul desperately needs a refresher course on the meaning of life. Only a few have realized what a large part Copernicanism has played in the overall deterioration of society. As the poet [Johann Wolfgang von Goethe](#) once wrote:

But among all the discoveries and corrections probably none has resulted in a deeper influence on the human spirit than the doctrine of Copernicus....Possibly mankind has never been

demanded to do more, for considering all that went up in smoke as a result of realizing this change: a second Paradise, a world of innocence, poetry and piety: the witness of the senses, the conviction of a poetical and religious faith. No wonder his contemporaries did not wish to let all this go and offered every possible resistance to a doctrine which in its converts authorized and demanded a freedom of view and greatness of thought so far unknown, indeed not even dreamed of.²⁴

Herbert Butterfield, one of the more prominent scientific historians of our day, proffered the same assessment when he noted that the Copernican revolution

...outshines everything since the rise of Christianity and reduces the Renaissance and Reformation to the rank of mere episodes, mere internal displacements, within the system of medieval Christendom. Since it changed the character of men's habitual mental operations even in the conduct of the non-material sciences, while transforming the whole diagram of the physical universe and the very texture of human life itself, it looms so large as the real origin both of the modern world and of the modern mentality, that our customary periodisation of European history has become an anachronism and an encumbrance.²⁵

Or in a more succinct yet blunt manner of speaking, perhaps the Copernican revolution has done what Slotte once said to Natalie in *The Winds of War*: "Christianity is dead and rotting since Galileo cut its throat."²⁶

Barring a conversion to geocentric cosmology, our modest goal is that, whoever reads these volumes will not leave them without realizing that what he has been taught about the Earth's annual journey around the sun is not so certain after all, and that similar to the rationale for deciding verdicts in a court of law, one should realize that there is enough evidence supporting geocentrism to cause a reasonable doubt in the minds of intelligent people.

Robert Sungenis
April 25, 2006

²⁴ Johann Wolfgang v. Goethe, *Zur Farbenlehre, Materialien zur Geschichte der Farbenlehre, Vierte Abteilung, Zwischenbetrachtung*, Deutscher Klassiker Verlag, Frankfurt am Main, 1991, Seite 666.

²⁵ Herbert Butterfield, *The Origins of Modern Science: 1300-1800*, New York, The Free Press, 1957, pp. 7-8.

²⁶ The words of Slotte to Natalie to prove the philosophical basis (as opposed to the economic basis) for the impetus to the 20th century German revolution (Herman Wouk, *The Winds of War*, Pocket Edition, 1973, p. 610).

For it is He who gave me unerring knowledge
of what exists, to know the structure of the world and
the activity of the elements;
the beginning and end and middle of times,
the alternations of the solstices
and the changes of the seasons,
the cycles of the year
and the constellations of the stars...
I learned both what is secret and what is manifest,
for wisdom, the fashioner of all things, taught me.

Wisdom 7:17-19, 21

"...the unsuccessful attempts to establish a motion of the Earth..."

[Albert Einstein](#)²⁷

"Briefly, everything occurs as if the Earth were at rest..."

[Henrick Lorentz](#)²⁸

"There was just one alternative; the earth's true velocity through space might happen to have been nil..."

[Arthur Eddington](#)²⁹

"The failure of the many attempts to measure terrestrially any effects of the earth's motion..."

[Wolfgang Pauli](#)³⁰

²⁷ Albert Einstein, "Zur Elektrodynamik bewegter Körper," *Annalen der Physik*, Vol. 17, 1905, pp. 891-892. In the same paragraph he writes: "...the same dynamic and optical laws are valid, as this for first-order magnitudes already has been proven," showing Einstein based Relativity on his supposition that Copernicanism is a "proven" fact, which it is not.

²⁸ From Lorentz's 1886 paper, "On the Influence of the Earth's Motion of Luminiferous Phenomena," as quoted in Arthur Miller's *Albert Einstein's Special Theory of Relativity*, p. 20.

²⁹ Arthur Eddington, *The Nature of the Physical World*, New York, Macmillan Company and Cambridge University Press, 1929, pp. 11, 8, in sequence.

³⁰ Wolfgang Pauli, *The Theory of Relativity*, New York, Dover Publications, 1958, p. 4.

"We do not have and cannot have any means of discovering whether or not we are carried along in a uniform motion of translation."

Henri Poincaré³¹

"A great deal of research has been carried out concerning the influence of the Earth's movement. The results were always negative.

Henri Poincaré³²

"This conclusion directly contradicts the explanation... which presupposes that the Earth moves..."

Albert Michelson³³

"The data were almost unbelievable.... There was only one other possible conclusion to draw — that the Earth was at rest."

Bernard Jaffe³⁴

"...nor has any physical experiment ever proved that the Earth actually is in motion."

Lincoln Barnett³⁵

³¹ From Poincaré's lecture titled: "L'état actuel et l'avenir de la physique mathématique," St. Louis, Sept. 24, 1904, *Scientific Monthly*, April, 1956.

³² From Poincaré's report *La science et l'hypothèse* ("Science and Hypothesis") published in 1901, now published in Paris, Flammarion, 1968, p. 182, as cited in Ludwik Kostro's, *Einstein and the Ether*, Aperion, 2000, p. 30.

³³ Albert A. Michelson, "The Relative Motion of the Earth and the Luminiferous Ether," *American Journal of Science*, Vol. 22, August 1881, p. 125, said after his first interferometer experiment could not detect the movement of ether against the Earth.

³⁴ Bernard Jaffe, *Michelson and the Speed of Light*, New York, Doubleday, 1960, p. 76. Jaffe, however, adds this conclusion on to the above sentence: "This, of course, was preposterous."

³⁵ Lincoln Barnett, *The Universe and Dr. Einstein*, New York, New American Library, 2nd revised edition, 1957, p. 73.

Chapter 1

The New Galileo and The Real Truth about Copernicanism

Galileo Was Wrong? How could modern men from the twenty-first century dare to name a book with such a title? No doubt, almost every book written about the Galileo affair in modern times begins with the premise that Galileo's cosmology was correct and the Catholic Church that condemned him was very mistaken. Typical remarks in a book about Galileo begin with very stern and foreboding words. The reader is simply not permitted to entertain any other possibility. As one author put it: "Galileo...who produced *the irrefutable proofs of the Sun-centered system*...came into direct and disastrous conflict with the Church."³⁶ Another says: "Readers, who know quite well that the Earth goes around the sun..."³⁷ The reader, not knowing any differently, doesn't give the author's assertion a second thought. All his life he has been taught that the Earth revolves around the sun, and he has placed himself under the edict that this particular teaching of modern science is no more to be doubted than the fact that fish swim or that birds fly.

As the typical author begins from the unquestioned premise that Galileo's sun-centered world was correct, he will postulate various reasons why the Catholic Church did not accept this new and improved model of the universe. The suggestions are many and varied, ranging from "ecclesiastical bureaucracy," "deliberate chicanery," "religious fundamentalism," "corporate interests" to "unfair tactics,"³⁸ but there is little doubt that virtually all the biographers and historians will invariably dismiss the possibility that Galileo could have been wrong.

³⁶ Ivan R. King, *The Unfolding Universe*, New York, W. H. Freeman, 1976, p. 132, emphasis added. Ivan King was professor of astronomy at the University of California, Berkeley.

³⁷ Giorgio de Santillana, *The Crime of Galileo*, New York, Time Inc., 1962, editor's preface, pp. viii-ix. De Santillana's major thesis is stated very early in the book: "...the tragedy was the result of a plot of which the hierarchies themselves turned out to be the victims no less than Galileo – an intrigue engineered by a group of obscure and disparate characters in strange collusion who planted false documents in the file, who later misinformed the Pope and then presented to him a misleading account of the trial for decision" (p. xx). Suffice it to say, our book will show that it is de Santillana who has been the victim of an intrigue engineered by a group of prominent and influential scientists in collusion, who made false conclusions from scientific experiments and then presented a misleading account to the public.

³⁸ These are some of the various reasons given for the Church's rejection of Galileo's theory in the opening pages of Santillana's *The Crime of Galileo* (pp. ix, xv, xx).

Galileo Conversion to Geocentrism

Although it will certainly come as a shock to most people, one very important reason we argue against heliocentrism is that we are revealing the wishes of none other than [Galileo](#)³⁹ himself. Unbeknownst to almost every modern reader, and even most historians, is the fact that just one year prior to his death Galileo made it very clear to his former allies where he now stood on the subject of cosmology. On the 29th of March 1641, Galileo responded to a letter that he received from his colleague Francesco Rinuccini, dated the 23rd of March 1641, containing discoveries made by the astronomer Giovanni Pieroni concerning the parallax motion of certain stars, from which both Rinuccini and Pieroni believed they had uncovered proof of the heliocentric system. Rinuccini writes to Galileo:

Your Illustrious Excellency, Signor Giovanni Pieroni has written to me in recent months telling how he had clearly observed with an optical instrument the movement of a few minutes or seconds in the fixed stars, but with just that level of certainty that the human eye can attain in observing a degree. All this afforded me the greatest pleasure - witnessing such a conclusive argument for the validity of the Copernican system! However, I have felt no little confusion because of something I read a few days ago in a bookshop. I happened to look at a book that is just now on the verge of being published. According to the author, if it were true that the sun is the center of the universe, and that the Earth travels around it once every year, it would follow that we would never be able to see half of the whole sky by night, because the line passing through the center and the horizons of the Earth, touching the periphery of the great orb, is a cord of a piece of the arc of the circle of the starry heavens, the diameter of which passes through the center of the sun. And since I have always believed it to be true - not having personally witnessed it - that the first [star] of Libra rises at the same moment as the first [star] of Aries sets, my limited intelligence has been unable to arrive at a solution. I therefore implore you, in your very great kindness, to remove this doubt from my mind. I will be very greatly obliged to you. Reverently kissing your hand, etc. Francesco Rinuccini.”⁴⁰

³⁹ Galileo Galilei was also Latinized to Galileus Galileus, which was often the way Galileo signed his name, as for example in his exchange of letters with Kelper in 1597. He was also called Galileo Galilei Linceo.

⁴⁰ The original Italian reads: “Dal Sig^r Cap. Giovanni Pieroni mi fu scritto a’ passati mesi [3960, 3966, 3980], come haveva chiaramente osservato con l’occhiale il moto nelle stelle fisse di alquanti minuti secondi, ma con tanta sicurezza quanta con l’occhio si saria potuto osservare un grado; che fu da me inteso con sommo gusto, per vedere così concludente argomento per la validatà del sistema Copernicano. Ma mi è vento non poco intorbidato dalla lettura che a questi giorni feci, in bottega di un librarò,

Galileo, not being particularly moved by the assertions, writes this surprising response to Rinuccini:

The falsity of the Copernican system should not in any way be called into question, above all, not by Catholics, since we have the unshakeable authority of the Sacred Scripture, interpreted by the most erudite theologians, whose consensus gives us certainty regarding the stability of the Earth, situated in the center, and the motion of the sun around the Earth. The conjectures employed by Copernicus and his followers in maintaining the contrary thesis are all sufficiently rebutted by that most solid argument deriving from the omnipotence of God. He is able to bring about in different ways, indeed, in an infinite number of ways, things that, according to our opinion and observation, appear to happen in one particular way. We should not seek to shorten the hand of God and boldly insist on something beyond the limits of our competence.... D'Arcetri, March 29, 1641. I am writing the enclosed letter to Rev. Fr. Fulgenzio, from whom I have heard no news lately. I entrust it to Your Excellency to kindly make sure he receives it.”⁴¹

casualmente di un libro che sta per uscire in luce, dove lessi che se fusse vero che il sole fusse nel centro e la terra gli girasse intorno per l'orbe magno nello spatio di un anno, seguirebbe che da noi non si vedrebbe mai la notte la metà del cielo, poichè la linea che passa per il centro e per gli orizzonti della terra, toccando la periferia dell'orbe magno, è una corda di un pezzo d'arco del cerchio del cielo stellato, il cui diametro passa, per il centro del sole. E perchè io ho sempre creduto che sia vero, non l'havendo visto per esperienza, che quando nasce il primo di Libra tramonti il primo di Ariete, non arrivo con la mia poca intelligenza a trovarne la solutione. Supplico dunque l'immensa sua gentilezza a rimuovere dalla mia mente questa dubitatione, che glie ne restero con soma obligatione: e gli bacio reverentemente le mani. Venetia, 23 marzo 1641. Di V.S. molto Ill.^{re} et Ecc.^{ma} Aff.^{mo} et Obb.^{mo} Se.^{re} S.^r Galileo Galilei. Fran.^{co} Rinuccini” (*Le Opere Di Galileo Galilei*, Nuova Ristampa Della Edizione Nazionale, Sotto L'Alto Patronato Del Presidente Della Repubblica Italiana, Giuseppe Saragat, direttore: Antonio Favaro, Vol. XVIII, Firenze, G. Barbèra – Editore, 1968, p. 311. Translated by Fr. Brian Harrison.

⁴¹ The original Italian reads: “Ill.^{mo} Sig.^r et P.ron mio Col.^{mo}. La falsità del sistema Copernicano non deve essere in conto alcuno messa in dubbio, e massime da noi Cattolici, havendo la inregrabile autorità delle Scritture Sacre, interpretate da I maestri sommi in teologia, il concorde assenso de' quali ci rende certi della stabilità della terra, posta nel centro, e della mobilità del sole intorno ad essa. Le congetture poi per le quali il Copernico et altri suoi seguaci hanno profferito il contrario si levono tutte con quell saldissimo argomento preso dalla onnipotenza di Iddio, la quale potendo fare in diversi, anzi in infiniti, modi quello che alla nostra opinione e osservazione par fatto in un tal particolare, non doviamo volere abbreviare la mano di Dio, e tenacemente sostenere quello in che possiamo essere ingannati...D'Arcetri, li 29 Marzo 1641. Scrivo l'alligata al R. P. Fulgenzio, dal quale è un pezzo che non ho nuove, e la raccomando a V. S. per il sicuro ricapito” (*Le Opere Di Galileo Galilei*, Nuova Ristampa Della Edizione Nazionale, Sotto L'Alto Patronato Del Presidente Della Repubblica Italiana, Giuseppe Saragat, direttore: Antonio Favaro, Vol. XVIII, Firenze, G. Barbèra – Editore, 1968, p. 316). A note added by the editor states: “Bibl. Naz. Fir.

Search as one might, few today will find Galileo's retraction of Copernicanism cited in books or articles written on the subject of his life and work. Fewer still are those in public conversation about Galileo who have ever heard that he recanted his earlier view. The reason is, quite simply, that the letter has been obscured from the public's eye for the last four centuries. As Galileo historian Klaus Fischer has admitted: "The ruling historiographers of science cannot be freed from the reproach that they have read Galileo's writings too selectively."⁴² Fortunately, Galileo's retraction managed to escape censorship and find its way among the rest of his letters in the twenty-volume compendium *Le Opere di Galileo Galilei* finally published in 1968. Centuries prior to its publication, there was a concerted effort by either Rinuccini or someone behind the scenes to cover up the fact that the letter was, indeed, written and sent by Galileo. We know this to be the case since a rather obvious attempt was made to erase Galileo's name as the signatory of the letter. The compiler of the original letter makes this startling notation: "The signature 'Galileo Galilei' has been very deliberately and repeatedly rubbed over, with the manifest intention of rendering it illegible."⁴³

Stillman Drake, one of the top Galileo historians in the world, noticed the subterfuge and commented:

Among all Galileo's surviving letters, it is only this one on which his name at the end was scratched out heavily in ink. I presume that Rinuccini valued and preserved Galileo's letters no matter what they said, but did not want others to see this declaration by Galileo that the Copernican system was false, lest he be thought a hypocrite.⁴⁴

Banco Rari, Armadio 9, Cartella 5, 33. – Originale, di mano di Vincenzo Viviani." This means that the letter is stored in the rare archives of the National Library at Florence in the rare books department, in cabinet #9, folder #5, 33 and written in the original hand of Vincenzo Viviani, since Galileo was blind in both eyes in 1641. Viviani was Galileo's last pupil and first biographer. NB: Viviani had performed the first Foucault-type pendulum experiment in 1661. Galileo's letter to Rinuccini was translated into English by Fr. Brian Harrison upon request. Stillman Drake contains a similar translation in *Galileo At Work: His Scientific Biography*, Chicago, London, The University of Chicago Press, 1978, p. 417.

⁴² Klaus Fischer, *Galileo Galilei*, Munich, Germany, Beck, 1983, p. 114.

⁴³ The original Italian reads: "La firma 'Galileo Galilei' è stata accuratissimamente coperta di fregghi, con manifesta intenzione di renderla illeggibile" (*Le Opere Di Galileo Galilei*, p. 316, footnote #2). Translated by Fr. Brian Harrison.

⁴⁴ Stillman Drake, *Galileo At Work: His Scientific Biography*, Chicago, London, The University of Chicago Press, 1978, p. 418.

Judging from the contents of his letter to Rinuccini, it seems that for quite some time Galileo had been contemplating the problems inherent in the Copernican system, as well as his desire to convert back to an Earth-centered cosmology. The wording in his letter is rather settled and direct as it does not reflect someone who is confused or equivocating; rather, it holds the convictions of a man who has been swept off his feet by a more convincing position.

So startling are Galileo's remarks that Stillman Drake attempts to soften their impact and do his best to rehabilitate Galileo as a heliocentrist. Commenting on the letter, Drake says:

Galileo's reply to Rinuccini on 29 March may at first astonish the reader....Yet there was nothing hypocritical in Galileo's saying that all science, including astronomy, is a fiction to the extent that it lies beyond the range of practicable observations; indeed, astronomy as Copernicus left it could not be reconciled with many actually observed facts known to Galileo...more important yet is Galileo's flat statement that the traditional geocentric astronomy was even more erroneous than the heliocentric.⁴⁵

Here we see Drake implying that Galileo was denying Copernicanism merely because he saw both it and the Ptolemaic system as unable to explain the motions of the sun and planets. This is based on the part of Galileo's letter that says:

“And just as I deem inadequate the Copernican observations and conjectures, so I judge equally, and more, fallacious and erroneous those of Ptolemy, Aristotle, and their followers, when [even] without going beyond the bounds of human reasoning their inconclusiveness can be very easily discovered.”⁴⁶

⁴⁵ *Galileo At Work: His Scientific Biography*, Chicago, London, The University of Chicago Press, 1978, pp. 418-419. Drake adds: “Thanks to Galileo's own telescopic discoveries that was certainly true, while that astronomical instruments could not establish stellar parallax was not only true in his time but remained so for two centuries afterward.” Although this is true, Drake is basing his defense on the mistaken notion that authentic measurements of stellar parallax would have proved the case for heliocentrism. It would not, since, as we will see later in this volume, stellar parallax is easily explained from a geocentric model of the universe, and which fact honest scientists readily admit. Of note here also is that in 1669 Robert Hooke, and John Flamsteed a few years afterward, attempted to prove the motion of the Earth by stellar parallax, yet both failed (John Flamsteed, *Historia Coelestis Britannica*, 1725, ed., Allan Chapman, trans., Alison D. Johnson, National Maritime Museum Monograph, No. 52, 1982, pp. 179-180). Hooke writes about this experience in his book: *An Attempt to Prove the Motion of the Earth by Observation*, London, 1674. It was also in this book that Hooke presented the Inverse Square Law of the force of gravity, thirteen years before Newton published the same law in his famous *Principia*.

But Galileo's wording is much more explicit than what Drake admits. Even if we were to grant to Drake that Galileo saw various problems in the Ptolemaic system, his letter to Rinuccini is clearly setting in opposition the entire "Copernican system" over against "the unshakeable authority of the Sacred Scripture, interpreted by the most erudite theologians, whose consensus gives us certainty regarding the stability of the Earth, situated in the center, and the motion of the sun around the Earth." These carefully chosen words are not, as Drake would have it, merely an attempt to point out the difficulties in the Copernican system prior to Kepler's discovery of the elliptical orbits of the planets. Rather, Galileo's words are identical to those of [St. Robert Bellarmine](#) stated some twenty-five years earlier, when the heliocentric system was first condemned under [Pope Paul V](#) and the Holy Office because it attempted to put the Earth in motion against the solemn words of Holy Scripture. Whereas in 1616 Galileo was arguing that Scripture should *not* be taken literally when it spoke on cosmology, now, in 1641, Scripture's literal interpretation is Galileo's hammer, just as it was for Bellarmine.

That Galileo is renouncing the entire foundation of heliocentric cosmology is noted both in his unqualified acceptance of the "stability of the Earth, situated in the center, and the motion of the sun around the Earth," and his reference to "the conjectures of Copernicus *and other followers*," of whom [Kepler](#), having been the first astronomer publicly to endorse Copernicus, was indeed one of his most ardent "followers," and one to whom Galileo was in correspondence on brief occasions. Not only is Galileo condemning Copernicanism by indicating that it is contrary to Scripture, he reinforces his line of reasoning by arguing that "the omnipotence of God" is "able to bring about in different ways, indeed, in an infinite number of ways" things we regard as improbable or impossible.

Galileo concludes his letter to Rinuccini by two other revealing statements. In the first, Galileo asserts that he can discredit the findings of Pieroni by an *a priori* assumption – that the Earth is in the center of the universe; and in the second, by renouncing his "unfortunate Dialogue" – the now famous book, titled more fully *The Dialogue Concerning the Two Chief World Systems* that [Pope Urban VIII](#) and the Sacred Congregation condemned in 1633 for its unqualified support of heliocentrism. He writes:

And since you say you are perplexed and disturbed by [that is, in answering] the argument taken from our always seeing one-half the sky above the horizon from which it can be concluded

⁴⁶ Original Italian: "E come che io stimi insufficienti le osservazioni e conietture Copernicane, altr'e tanto reputo più fallacy et erronee quelle di Tolomeo, di Aristotele e de'loro seguaci, mentre che, senza uscire de' termini de' discorsi humani, si può assai chiaramente scoprire la non concludenza di quelle" (*Le Opere Di Galileo Galilei*, p. 315).

with Ptolemy that the Earth is in the center of the stellar sphere...reply to the author [Pieroni] that truly one-half the sky is not seen, and deny this to him until he makes you certain that exactly half is seen – which he will never do. For whoever has said positively that half the sky is seen, and that therefore the Earth is established at the center, has it in his head to begin with that the Earth is established at the center, which is why he says that half the sky is seen – because that is what would have to happen if the Earth were at the center. So it is not from seeing half the sky that the Earth's being in the center is inferred [by these men], but it is deduced from the assumption that the Earth is at the center that half the sky is seen...⁴⁷

Now let us add that if the observations of Captain Pieroni be true about the motions of some fixed stars, made through a few seconds of arc, [then] small as these are, [this] implies to human reasoning changes by the Earth different from any that can be attributed to it [while] retained at the center. And if there is such a change, and it is observed to be less than one minute of arc, who wants to guarantee to me that when the first point of Aries rises, the first point of Libra sets so precisely that there is not even a difference to us of one minute of arc?...Hence what should we want to deduce, in a very delicate and subtle observation, from experiences that are crass and even impossible to make? I might add other things on this subject, *but what was already said in my unfortunate Dialogue may suffice.*⁴⁸

⁴⁷ Translation by Stillman Drake, *Galileo At Work*, pp. 417-418, emphasis added. Original Italian without the ellipse reads: “E poi che V. S. Ill. Dice restar perplessa e perturbata dall’argomento preso dal vedersi continuamente la metà del cielo sopra l’orizzonte, onde si possa con Tolomeo concludere la terra esser nel centro della sfera stellata, e non da esso lontana quanto è il semidiametro dell’orbe magno, risponda all’autore che è vero che non si vede la metà del cielo, e glie lo neghi sin che egli non la rende sicura che si vegga giustamente tal metà; il che non farà egli già mai. Et assolutamente chi ha detto, vedersi la metà del cielo, e però esser la terra collocata nel centro, ha prima nel suo cervello la terra stabilita nel centro, e quindi affermato vedersi la metà del cielo, perchè così dovrebbe accadere quando la terra fusse nel centro; sì che non dal vedersi la metà del cielo si è inferito la terra esser nel centro, ma raccolto dalla supposizione che la terra sia nel centro, vedersi la metà del cielo” (*Le Opere Di Galileo Galilei*, p. 315).

⁴⁸ Translation by Stillman Drake, *Galileo At Work*, p. 418, emphasis added. Original Italian without the ellipse reads: “Aggiunghiamo hora che sia vera la osservazione del Sig. Capitan Pieroni del moto di alcuna fissa, fatto con alcuni minuti secondi: per piccolo che egli sia, inferisce, a gli humani discorsi, mutazione nella terra diversa da ognuna che, ritenendola nel centro, potesse essergli attribuita. E se tal mutazione è, et si osserva esser meno di un minuto primo, chi vorrà assicurarmi se, nascendo il primo punto d’Ariete, tramonti il primo di Libra così puntualmente che non ci sia differenza nè anco di un minuto primo? Sono tali punti invisibili; gli orizzonti, non così precisi in terra, nè anco tal volta in mare; strumenti astronomici ordinarii non possono essere così esquisiti che ci assicurino in cotali osservazioni dall’errore di un minuto; e finalmente, le refrazioni appresso all’orizzonte posson fare alterazioni tali, che portion inganno non

Hence, far from being a hero of modern cosmology, shortly before his death Galileo had become its worst adversary – a fact of history that has been either quietly ignored or deliberately suppressed. Of course, there are some who might refute this dramatic conversion of the former troublemaker by pointing out that Galileo was under house arrest beginning in 1633 by order of Pope Urban VIII. One might conjecture that, not wishing to agitate the pope, Galileo was merely speaking under duress, and thus his words are not to be considered convincing evidence that he had abandoned his former views of cosmology. Although such a rationale is certainly possible, we get no hint of it in Galileo’s carefully chosen words. Drake certainly didn’t see Galileo’s letter that way, since he interprets it with all the seriousness with which he assumes Galileo wrote it. Being the proud man Galileo was known to be, if his motive was merely to keep peace with the pope and preserve his fortunes, a simple and polite denial to Rinuccini’s claims was all that was necessary. Instead, Galileo is defending the immobility of the Earth with such an exuberance of spirit and logic that he appears to be the epitome of a man who has had his ‘eureka’ moment and will not be denied. Charlatans have few convictions; those under duress guard their words and often equivocate; politicians often play favorites and say what will bring them

sol di uno, ma di molti e molti minuti, come questi medisimi osservatori concederanno. Adunque, che vogliamo raccorre in una delicatissima e sottilissima osservazione da esperienze grosso lanissime et anco impossibili a farsi? Potrei soggiugner alter cose in questo proposito, ma il già detto nel mio Dialogo sfortunato dice tanto che può bastare” (*Le Opere Di Galileo Galilei*, pp. 315-316). The final paragraph appearing in *Le Opere Di Galileo Galilei* is: “Il Sig.^f Liceti debbe star rispondendo a quella mia lettera, la quale gli darà campo di portare nuovi et acutissimi pensieri; et il medesimo Sig.^f Liceti haverà comoda occasione di farsi sentire ancora ad un altro suo antagonista, coìe al nostro qua Sig.^f midico Nardi, il quale ha mandato nuovamente in luce un trattato de’ fuochi sutterranei, al quale egli Annette cento problemi naturali con le loro risoluzioni. Vegga V.S. Ill.^{ma} il libro, et in particolare I problemi, che son tutti investigati dal proprio ingegno dell’autore; et in una lettura di poco più di un’ ora vedrà la soluzione di tanti mirabili effetti della natura, che un solo mi ha messo in disperazione di intenderlo con la contemplazione del tempo di tutta mia vita. Nè mi occorrendo altro per ora, finisco con augurargli felice questa Santa Pasqua, con confermarmegli devotissimo servitore.” The following is its translation: “Signor Liceti should be responding to that letter of mine, which will afford him the opportunity to contribute new and very penetrating ideas. And the same Signor Liceti will thus have a convenient occasion to get his message through once again to another of his opponents, namely, our medical friend Signor Nardi. The latter has just published another treatise on the fires beneath the Earth’s surface, this time with an Addendum setting out one hundred problems of natural science, together with their solutions. I warmly recommend that Your Excellency look at this book, especially the aforesaid problems, all of which the author has investigated personally, and with great skill. In a little over an hour’s reading you will see the explanation of a great number of marvelous natural phenomena. Just one of these had been the object of my own studies over a lifetime, but I had despaired of ever being able to understand it. Since I have nothing more to add at this moment, I will end by wishing you a happy and holy Easter. While assuring you that I remain, Your most devoted servant, Galileo Galilei” (Translation by Fr. Brian Harrison).

popularity; but Galileo exhibits none of these vices in his letter. He takes sides with no one; rather, he equally condemns Ptolemy, Copernicus and Kepler, for he realizes that none of them have answered all that he has seen in his telescope, and only God Himself knows how it fits together.⁴⁹ Hence, he rests his case not with *any* scientific theory but with the “omnipotence of God,” Who merely speaks and all is accomplished. In fact, Rinuccini, after reading Galileo’s letter, was so thoroughly convinced of its sincerity that it became the very reason he attempted to scratch Galileo’s signature off what he knew would change the course of history had it been revealed to the public.

Where might Galileo have heard the persuasive “omnipotence of God” line of argumentation? It most likely came from [Pope Urban VIII](#) in 1633. Scientifically speaking, by this time Urban was already armed with [Tycho de Brahe’s alternative model of cosmology](#), which was presented to the world a half century earlier and which graphically demonstrated how easy it is to envision the sun and planets circling the Earth while adhering to all the proportions and motions that were in Galileo’s heliocentric model. Knowing this, Urban could then speak quite confidently from both a scientific and theological perspective, and thus assure Galileo that not only was the weight of the evidence against him, but in refusing to accept the Church’s verdict he would then find himself contending with the Almighty. In the pope’s words to Galileo:

Let Us remind you of something that We had occasion to tell you many years ago, speaking as one philosopher to another; and, if We remember, you were not willing then to offer Us any definite refutation.

Let Us grant you that all of your demonstrations are sound and that it is entirely possible for things to stand as you say. But now tell Us, do you really maintain that God could not have wished or known how to move the heavens and the stars in some other way? We suppose you will say ‘Yes,’ because We do not see how you could answer otherwise. Very well then, if you still want to save your contention, you would have to prove to Us that, if the heavenly movements took place in another manner than the one you suggest, it would imply a logical contradiction at some point, since God in His infinite power can do anything that does not imply a contradiction. Are you prepared to prove as much? No? Then you will have to concede

⁴⁹ As Imre Lakatos notes: “One can hardly claim that Copernicus deduced his heliocentrism from the facts. Indeed, now it is acknowledged that both Ptolemy’s and Copernicus’s theories were inconsistent with known observational results” (*The Methodology of Scientific Research Programmes*, p. 170). Lakatos adds a comment from Gingerich: “...in Tycho’s observation books, we can see occasional examples where the older scheme based on the Alfonsine Tables yielded better predictions than could be obtained from the Copernican Prutenic Tables” (“The Copernican Celebration,” *Science Year*, 1973, pp. 266-267).

to Us that God can, conceivably, have arranged things in an entirely different manner, while yet bringing about the effects that we see. And if this possibility exists, which might still preserve in their literal truth the sayings of Scripture, it is not for us mortals to try to force those holy words to mean what to Us, from here, may appear to be the situation.

Have you got anything to object? We are glad to see that you are of Our opinion. Indeed, as a good Catholic, how could you hold any other? To speak otherwise than hypothetically on the subject would be tantamount to constraining the infinite power and wisdom of God within the limits of your personal ideas [*fantasie particolari*]. You cannot say that this is the only way God could have brought it about, because there may be many, and perchance infinite, ways that He could have thought of and which are inaccessible to our limited minds. We trust you see now what We meant by telling you to leave the theology alone.⁵⁰

⁵⁰ Giorgio de Santillana, *The Crime of Galileo*, New York, Time Inc., 1962, pp. 175-176. Santillana adds: "Historians usually date this idea from the conversation of 1630. But we have seen (p. 135) that it is mentioned in Oregius' *Praeludium*, whence we have paraphrased the statement quoted below. The passage in question, according to Berti, occurs also in the first edition of 1629. Hence the argument dates back at least to 1624 and probably, as Oregius implies, was used for the first time in 1616."

Copernicanism's Procrustean Bed

Opposed to the repentant and converted Galileo, however, most of today's scientists impose on us to believe, so said [Carl Sagan](#) (d. 1996), that "we live on an insignificant planet of a humdrum star lost in a galaxy tucked away in some forgotten corner of a universe in which there are far more galaxies than people," and all of which popped into existence, by chance, "billions and billions" of years ago.⁵¹ Unfortunately, this glum picture of our place in the universe is, in the estimation of its most cherished icons, the springboard of all modern science. In the words of one of its leading figures, [Stephen Jay Gould](#) (d. 2002):

The most important scientific revolutions all include, as their only common feature, the dethronement of human arrogance from one pedestal after another of previous convictions about our centrality in the cosmos.⁵²

There is probably no statement better than Gould's that sums up the motivations, aspirations, and convictions of the modern scientific community. All of modern science, in one form or another, is based on the Copernican premise that the Earth revolves around the sun. To posit otherwise is, as one scientist put it, "a depressing thought."⁵³ In brief, heliocentrism has served as the quintessential catapult to release science from the so-called 'constraints of religion,' and it has never looked back.

Of course, the other side of the story is, if Gould and his colleagues are wrong, then "the most important scientific revolution" of all time waits to be restored to its rightful place. Earth, as the center of the universe, motionless in space wherein all other celestial bodies revolve around it, would destroy, in one mortal blow, the theories of evolution, paleontology, cosmology, cosmogony, relativity, and many

⁵¹ Carl Sagan, "On the Significance of Man," *Time*, October 20, 1980, p. 61.

⁵² Stephen Jay Gould, *Dinosaur in a Haystack: Reflections in Natural History*, New York: Harmony Books, 1996. When it comes to proving the implications of heliocentrism, Gould is not so self-assured: "These are two things that we can't comprehend. And yet theory almost demands that we deal with it. It's probably because we're not thinking about them right. Infinity is a paradox within Cartesian space, right? When I was eight or nine I used to say, 'Well, there's a brick wall out there.' Well, what's beyond the brick wall? But that's Cartesian space, and even if space is curved you still can't help thinking what's beyond the curve, even if that's not the right way of thinking about it. Maybe all of that's just wrong! Maybe it's a universe of fractal expansions! I don't know what it is. Maybe there are ways in which this universe is structured we just can't think about" (Interview with John Horgan, cited in *The End of Science*, New York: Broadway Books, 1996, p. 125).

⁵³ Donald Goldsmith, *The Evolving Universe*, Menlo Park, CA, The Benjamin/Cummings Publishing Company, 1985, p. 140.

other modern disciplines, placing them all on the dust heap of history. If Earth is in the center of the universe, it means, with little argument from the science community, that Someone placed it there by design. Gould realized that fact better than anyone else. But with all due respect to Gould, it is not “arrogance” that leads one to see the Earth as the center of the universe. Rather, humility guides the human soul to recognize that there is Someone much higher than we Who has esteemed Earth so much that He put it in a most unique place in the universe to be the apple of His eye. Arrogance is on the side of those who would seek to remove that Someone from our immediate purview by throwing the Earth into the remote recesses of space. As Galileo historian Arthur Koestler concluded:

The notion of limitlessness or infinity, which the Copernican system implied, was bound to devour the space reserved for God...This meant, among other things the end of intimacy between man and God. Homo sapiens had dwelt in a universe enveloped by divinity as by a womb; now he was being expelled from the womb. Hence Pascal’s cry of horror.⁵⁴

Not far behind Gould’s sentiments is another science icon, [Stephen Hawking](#):

[We have moved] from the revolutionary claim of Nicolaus Copernicus that the Earth orbits the sun to the equally revolutionary proposal of Albert Einstein that space and time are curved and warped by mass and energy. It is a compelling story because both Copernicus and Einstein have brought about profound changes in what we see as our position in the order of things. Gone is our privileged place at the center of the universe, gone are eternity and certainty, and gone are absolute space and time...⁵⁵

So not only does science wish to remove Earth from the center, the demotion also dictates that the things we have always held as reliable

⁵⁴ Arthur Koestler, *The Sleepwalkers: A History of Man’s Changing Vision of the Universe*, Peilican Books Ltd., England, 1959, reprinted 1979, p. 222. Koestler is referring to Blaise Pascal (d. 1662), a Catholic (Jansenist) philosopher/scientist who was unsure of God’s existence and desperately tried to fill the void. He is noted for saying: “I am terrified by the emptiness of these infinite spaces” (*Pensées sur la religion*, 1669). Echoing similar sentiments, Edmund Burke stated in 1757: “Infinity has a tendency to fill the mind with that sort of delightful horror...” *A Philosophical Enquiry into the Origin of Our Ideas of the Sublime and Beautiful*, Oxford: Basial Blackwell, pp. 129, 431.

⁵⁵ *On the Shoulders of Giants*, ed., Stephen Hawking, Phila., PA, Running Press Book Publishers, 2002, p. ix.

guideposts to our lives are suddenly torn away from us. An Earth set adrift will invariably make everything else relative and thus, as Hawking admits, will turn the notions of “certainty” and “absolutes” into mere figments of our imagination.

Curiously, Gould and Hawking don’t seem bothered by this insidious unsettling of our world. In fact, they seem rather predisposed to it. They would have surely been opposed to Galileo’s conversion (which Galileo based on his Catholic faith), and the reason, perhaps, has something to do with their self-attested atheism and their allegiance to rationalism and materialism. They know deep down in their souls that if they can keep the Earth in the outer recesses of space, there is no longer clear evidence that the Someone exists, and they can live their lives happily ever after.

Thus, the message of modern man, enshrined as it is in the gospel of [Nicolaus Copernicus](#),⁵⁶ has literally, and figuratively, turned the world upside down. Copernicanism is the foundation for modern man’s independence from God, a connection that was recognized by none other than the editor of the world’s most prestigious scientific journal. When confronted in the late 1970s with the new model of cosmology invented by the well-known physicist George F. R. Ellis (a cosmology that proposed the Earth was in a central position in the universe), [Paul C. W. Davies](#), the editor of *Nature*, was forced to reply: “His new theory seems quite consistent with our astronomical observations, even though it clashes with the thought that we are godless and making it on our own.”⁵⁷

⁵⁶ Nicolaus Copernicus is the Latinized version of the original Polish name Nicklaus Koppemigk. While the spelling of the first name varies between Nicklaus, Niklas, and Nicolaus, the last name has had more of a variety: Coppernic, Koppemieck, Koppemik, Koppemigk, Cupernick, and Kupernick. Copernicus signed his name in various ways as well: Copernic, Coppemig, Coppemik, Coppemnic, but in later years mostly as Copernicus. He is also referred to as Nicklaus Koppemigk Warmiensis, since he was from the province of Warmia in Poland. Ironically, in the Frankonian local dialect of Poland, *koepperneksch* still means “a far-fetched, cockeyed proposition” (Koestler, *The Sleepwalkers*, p. 191).

⁵⁷ P. C. W. Davies, “Cosmic Heresy?” *Nature*, 273:336, 1978. In the same article Davies admits: “...as we see only redshifts whichever direction we look in the sky, the only way in which this could be consistent with a gravitational explanation is if the Earth is situated at the center of an inhomogeneous Universe.” Confirming Davies’ agnosticism is a letter he wrote to me on August 9, 2004, stating: “I have long argued against the notion of any sort of God who resides within time, and who preceded the universe.” Davies, however, is honest enough to admit he cannot lightly dismiss Ellis’ science or mathematics that connect the Earth with the center of the universe. As for Ellis, he believes in a spherical dipole universe in which the Earth is the south pole position or “antipole,” while the point at which the Big Bang exploded is the north pole or “center.” The diameter between the center and antipole is the longest distance in the universe. His model merely takes the singularity from the past and puts it in the present. As he says in another paper: “In the FRW [Friedmann-Robertson-Walker] universes [viz., the Big Bang], the singularity is hidden away inaccessibly in the past; in these universes, it is sitting ‘over there’ (in a sense, surrounding the Universe), where it

[Albert Einstein](#), whose theory of Relativity sought to eliminate the possibility of having any point in the cosmos serve as a center, knew instinctively that the choice between a heliocentric or geocentric system was, from both a scientific and philosophical point of view, totally arbitrary. From the scientific viewpoint he enlightens us with these words:

The struggle, so violent in the early days of science, between the views of Ptolemy and Copernicus would then be quite meaningless. Either CS [coordinate system] could be used with equal justification. The two sentences: “the sun is at rest and the Earth moves,” or “the sun moves and the Earth is at rest,” would simply mean two different conventions concerning two different CS [coordinate systems].⁵⁸

Consequently, Einstein concludes:

When two theories are available and both are compatible with the given arsenal of facts, then there are no other criteria to prefer one over the other except the intuition of the researcher. Therefore one can understand why intelligent scientists, cognizant both of theories and of facts, can still be passionate adherents of opposing theories.⁵⁹

Physicist Herbert Dingle, one of Einstein’s most vehement critics, understood the implications very well. He writes:

But velocity has no meaning apart from an accepted standard of rest, and the principle of relativity is the principle that there

can influence, and be influenced by, the Universe continually...for this continuing interaction might be envisaged as the process which keeps the Universe in existence” (“Ellis, Maartens and Nel, “The Expansion of the Universe,” *Monthly Notices of the Royal Astronomical Society*, 1978, p. 447). Ellis presented his radical view in a 1979 essay contest sponsored by the Gravity Research Foundation. Our point here, however, is not to condone Ellis’ model of the universe, but only to show that even a hint of Earth’s centrality prompts scientific philosophers such as Davies to recognize its divine implications.

⁵⁸ *The Evolution of Physics: From Early Concepts to Relativity and Quanta*, Albert Einstein and Leopold Infeld, New York, Simon and Schuster, 1938, 1966, p. 212. In another sense, Relativity has no basis making such judgments, for as Einstein himself notes: “The theory of relativity states: ‘The laws of nature are to be formulated free of any specific coordinates because a coordinate system does not conform to anything real’” (*Annalen der Physik* 69, 1922, 438, cited in *The Expanded Quotable Einstein*, p. 244).

⁵⁹ “Induction and Deduction in Physics,” *Berliner Tageblatt*, December 25, 1919. Cited in *The Expanded Quotable Einstein*, p. 237.

is no such standard fixed by nature but that you may adopt any standard you wish.⁶⁰

We, of course, offer a return to an immobile Earth as the “accepted standard of rest,” which, of course, will terminate any dependence on Relativity theory. Still, even though Relativity theory, if followed to its logical conclusion will not allow anyone to rest his case with Copernicus, most of the world will cling to it, either from sentiment or personal preference. Einstein knew this too. From a more philosophical point of view he admits that we pick the universe with which we are most emotionally comfortable:

This is what the painter, the poet, the speculative philosopher, and the natural scientists do, each in his own fashion. Each makes the cosmos and its construction the pivot of his emotional life, in order to find in this way peace and security which he can not find in the narrow whirlpool of personal experience.⁶¹

Until these admissions were afforded to us, however, the dawn of Copernicanism faced mankind with a revolution in human thinking unsurpassed by any single event, save Noah’s flood and the advent of Jesus Christ. As Alexander Koyré understood it:

The dissolution of the Cosmos...this seems to me to be the most profound revolution achieved or suffered by the human mind since the invention of the Cosmos by the Greeks. It is a revolution so profound and so far-reaching that mankind – with very few exceptions, of whom Pascal was one – for centuries did not grasp its bearing and its meaning; which, even now, is often misvalued and misunderstood. Therefore what the founders of modern science, among them Galileo, had to do, was not to criticize and to combat certain faulty theories, and to correct or to replace them by better ones. They had to do something quite different. They had to destroy one world and to replace it by another. They had to reshape the framework of our intellect itself, to restate and reform its concepts, to evolve a new approach to Being, a new concept of knowledge, a new concept of science – and even to replace a pretty natural

⁶⁰ Herbert Dingle, *The Special Theory of Relativity*, London, Methuen & Co, New York, John Wiley and Sons, 1961, p. vii. Dingle adds: “That makes ‘length’ of a body indefinite, and that means that all other physical measurements that are definitely related to length (i.e. all other physical measurements) must share that indefiniteness.”

⁶¹ Albert Einstein, *Ideas and Opinions*, Dell, Pinebrook, NJ, 1954; Wings, reprint edition, 1988.

approach, that of common sense, by another which is not natural at all.⁶²

Arthur Koestler says it this way:

The new philosophy destroyed the mediaeval vision of an immutable social order in a walled-in universe together with its fixed hierarchy of moral values, and transformed the European landscape, society, culture, habits and general outlook as thoroughly as if a new species had arisen on this planet.⁶³

James Burke adds:

The work, published in 1543, was called *On the Revolution of the Celestial Spheres*. It stated that the center of the universe was a spot somewhere near the sun...The scheme met the requirements of philosophical and theological belief in circular motion. In every other respect, however, Copernicus struck at the heart of Aristotelian and Christian belief. He removed the Earth from the center of the universe and so from the focus of God's purpose. In the new scheme man was no longer the creature for whose use and elucidation the cosmos had been created. His system also placed the Earth in the heavens, and in doing so removed the barrier separating the incorruptible from the corruptible.⁶⁴

Owen Barfield, in his penetrating book on human thought, suggests that the Copernican revolution dwarfs any other:

The real turning-point in the history of astronomy and of science in general was...when Copernicus...began to think, and others, like Kepler and Galileo, began to affirm that the heliocentric hypothesis not only saved the appearances, but was physically true. It was this, this novel idea that the Copernican (and therefore any other) hypothesis might not be a hypothesis at all but the ultimate truth, that was almost enough in itself to constitute the "scientific revolution," of which Professor Butterfield has written: "it outshines everything since the rise

⁶² Alexandre Koyré, "Galileo and Plato," *Journal of the History of Ideas*, vol. 4, no. 4, Oct. 1943. Koyré adds elsewhere: "The infinite Universe of the New Cosmology, infinite in Duration as well as in Extension, in which eternal matter in accordance with eternal and necessary laws moves endlessly and aimlessly in eternal space, inherited all the ontological attributes of Divinity. Yet only those – all the others the departed God took away with Him" (Alexandre Koyré, *From the Closed World to the Infinite Universe*, Johns Hopkins University Press, 1968, p. 276.)

⁶³ Arthur Koestler, *The Sleepwalkers*, p. 13.

⁶⁴ James Burke, *The Day the Universe Changed*, p. 135.

of Christianity and reduces the Renaissance and Reformation to the rank of mere episodes, mere internal displacements, within the system of medieval Christendom"...It was not simply a new theory of the nature of the celestial movements that was feared, but a new theory of the nature of theory; namely, that, if a hypothesis saves all the appearances, it is identical with truth.⁶⁵

Although Barfield does not give the citation, he is referring to the quote in Herbert Butterfield's book *The Origins of Modern Science: 1300-1800*.⁶⁶ Yet he left out the more significant of Butterfield's words:

Since it [the Copernican Revolution] changed the character of men's habitual mental operations even in the conduct of the non-material sciences, while transforming the whole diagram of the physical universe and the very texture of human life itself, it looms so large as the real origin both of the modern world and of the modern mentality, that our customary periodisation of European history has become an anachronism and an encumbrance.⁶⁷

E. A. Burt adds that after the Copernican revolution...

Man begins to appear for the first time in the history of thought as an irrelevant spectator and insignificant effect of the great mathematical system which is the substance of reality.⁶⁸

[Johann Wolfgang von Goethe](#) (d. 1832) said it even more poetically:

But among all the discoveries and corrections probably none has resulted in a deeper influence on the human spirit than the doctrine of Copernicus....Possibly mankind has never been demanded to do more, for considering all that went up in smoke as a result of realizing this change: a second Paradise, a world of innocence, poetry and piety: the witness of the senses, the conviction of a poetical and religious faith. No wonder his contemporaries did not wish to let all this go and offered every possible resistance to a doctrine which in its converts

⁶⁵ Owen Barfield, *Saving the Appearances: A Study in Idolatry*, 2nd edition, Wesleyan University Press, 1988, pp. 50-51.

⁶⁶ Herbert Butterfield, *The Origins of Modern Science: 1300-1800*, New York, The Free Press, 1957, p. 7.

⁶⁷ Herbert Butterfield, *The Origins of Modern Science: 1300-1800*, New York, The Free Press, 1957, pp. 7-8.

⁶⁸ E. A. Burt, *The Metaphysical Foundations of Modern Science*, Garden City, NY, Doubleday, Anchor Books, p. 90.

authorized and demanded a freedom of view and greatness of thought so far unknown, indeed not even dreamed of.⁶⁹

Friedrich Engels, co-author with Karl Marx of the *Communist Manifesto*, reveals that the Copernican revolution was the beginning of modern man's humanistic religion, and for added flavor, he describes its advancement in Newtonian terms:

What Luther's burning of the papal Bull was in the religious field, in the field of natural science was the great work of Copernicus...from then on the development of science went forward in great strides, increasing, so to speak, proportionately to the square of the distance in time of its point of departure...⁷⁰

C. S. Lewis adds:

Go out on a starry night and walk alone for half an hour, resolutely assuming that the pre-Copernican astronomy is true. Look up at the sky with that assumption in your mind. The real difference between living in that universe and living in ours will then, I predict, begin to dawn on you.⁷¹

The nihilist **Friedrich Nietzsche**, after seeing what the scientific revolution did to mankind, despondently concluded: "God is dead." What is even more significant is why Nietzsche proffered such sentiments. He writes:

"Where has God gone?" he cried. "I shall tell you. We have killed him – you and I. We are his murderers. But how have we done this? How were we able to drink up the sea? Who gave us the sponge to wipe away the entire horizon? What did we do when we unchained the Earth from its sun? Whither is it moving now? Whither are we moving now? Away from all suns? Are we not perpetually falling? Backward, sideward, forward, in all directions? Is there any up or down left? Are we not straying as through an infinite nothing? Do we not feel the

⁶⁹ Johann Wolfgang v. Goethe, *Zur Farbenlehre*, Materialien zur Geschichte der Farbenlehre, Vierte Abteilung, Zwischenbetrachtung, Deutscher Klassiker Verlag, Frankfurt am Main, 1991, Seite 666.

⁷⁰ Nicholas Rescher, *Scientific Progress*, Oxford, United Kingdom, Basil Blackwell, 1978, pp. 123-124. It is commonly admitted by historians that the Copernican Revolution spawned both the French and Bolshevik Revolutions. Karl Marx also remarks on his indebtedness to Copernicus.

⁷¹ C. S. Lewis, *Studies in Medieval and Renaissance Literature*, Cambridge University Press, 1966, p. 47. See also Lewis' other work: *The Discarded Image*, Cambridge University Press, 1964.

breath of empty space? Has it not become colder? Is it not more and more night coming on all the time? Must not lanterns be lit in the morning? Do we not hear anything yet of the noise of the gravediggers who are burying God? Do we not smell anything yet of God's decomposition? Gods, too, decompose. God is dead. God remains dead. And we have killed him. How shall we, murderers of all murderers, console ourselves?"⁷²

The references to "What did we do when we unchained the Earth from its sun?" or "Is there any up or down left?" show that Nietzsche is speaking about none other than the Copernican revolution and the cataclysmic upheaval it ignited in the hearts of men. Many moderns have repeated Nietzsche's quote with the interpolation "God is dead...Our science has killed him," but few have noticed that the science to which Nietzsche was referring is Copernicanism and its offshoots, regardless of whether Nietzsche agreed or disagreed with heliocentric cosmology. The poet John Donne expressed a similar sentiment:

The sun is lost, and th' Earth, and no man's wit
Can well direct him where to look for it.
And freely men confess that this world's spent,
When in the planets and the firmament
They seek so many new; they see that this
Is crumbled out again to his atomies
'Tis all in pieces, all coherence gone⁷³

⁷² "The Gay Science" in Nietzsche's *Thus Spoke Zarathustra* (1885). The above quote is not chosen to suggest that Nietzsche had any sympathies or sentiments towards God or religion, but only that, in his inimitable way, he saw the obvious truth that, to whatever degree, Copernicanism separated man from God. Rest assured, many other quotes reveal Nietzsche's negative feelings about God and religion: "I cannot believe in a God who wants to be praised all the time." "After coming in contact with a religious man, I always feel that I must wash my hands." Nietzsche eventually contracted syphilis and committed suicide.

⁷³ John Donne (d. 1631). The seven lines extracted above are from a 238-line poem titled, *An Anatomy of the World*.

The Real Truth About the Copernican Solar System

Unbeknownst to almost all modern-day believers in Copernicanism is one stark but incontrovertible fact: the popular idea of the Earth revolving around the sun has never been proven. Despite all the pretentious claims purporting to have proof for heliocentrism (which are made on the basis of such phenomena as stellar parallax, retrograde motion, the Foucault pendulum, the Coriolis effect, meteor showers, red shift, ring lasers, the equatorial bulge of the Earth and geosynchronous satellites: all of which, as we will demonstrate later in this volume, do not prove, in the least, the heliocentric system), honest scientists will candidly admit that heliocentrism is merely their *preferred* model of cosmology, but certainly not the proven one. Their numerous quotes to this effect are meticulously catalogued in our treatise. Historically speaking, stellar parallax is particularly important to this debate, since it was precisely a false claim of finding the first parallax (and hence the equally false claim that heliocentrism was a proven fact), that may have had an influence upon the authorities of the Catholic Church under Pope Gregory XVI who removed Copernicus and Galileo's works from the Index of Forbidden Books in 1835.⁷⁴ It is safe to conclude that if Pope Gregory had the information from modern science now available to the world, the Church would have never seen fit to give either Copernicus or Galileo even a tiny reprieve.

A thorough study of the original Copernican system, the very system the pre-1641 Galileo brought to the Catholic Church and demanded she accept, reveals a model racked with so many problems one wonders how it ever saw the light of day. In 1514 [Copernicus](#) was asked by [Pope Leo X](#) to use his talents to help fix the calendar. The calendar had been causing slight but pestering problems for many centuries. The last revision was initiated by Julius Caesar, who employed his astronomers to create what we now know as the Julian calendar, a calibration that incorporated 365¼ days per year, a marked improvement

⁷⁴ As cited by Owen Gingerich at St. Edmunds Public Lecture series, titled: "Empirical Proof and/or Persuasion," wherein he writes: "Hence, ironically, what persuaded the Catholic Church to take Copernicus' book off the Index was an ultimately false claim for the discovery of an annual stellar parallax. The new edition of the Index appearing in 1835 finally omitted *De Revolutionibus*, three years before a convincing stellar parallax observation was at last published." Gingerich cites his source for this information as Pierre-Noël Mayaud, S.J., *La Condamnation des Livres Coperniciens et sa Révocation: à la lumière de documents inédits des Congrégation de l'Index et de l'Inquisition* (Rome: Editrice Pontificia Università Gregoriana, 1997), no page number given. The thesis of our book, *Galileo Was Wrong*, is that, not only was the 1835 rescission of Copernicus' and Galileo's works presumptuous in light of the false parallax claims, even after 1838 (when Bessel published the first authenticated parallax) the case for heliocentrism was not proven, since parallax can also be explained equally well from a geocentric model. (See the *Galileo Was Wrong* CD program which shows the animation of both heliocentric and geocentric parallax).

from the previous 355 days per year.⁷⁵ One of the reasons Copernicus was invited to this project was that he had published a precursor of his heliocentric theory about the year 1510, titled *Commentariolus* (“Little Commentary”) antedating his more famous work *De revolutionibus orbium coelestium*, which was released some thirty years later, in 1543, the year of Copernicus’ death.⁷⁶ It is in the *Commentariolus* that Copernicus makes his first claim that the Ptolemaic system is unsatisfactory. Among the more salient features of the treatise are Copernicus’ three major premises: (1) “That the Earth is not the center of the universe, only of the moon’s orbit and of terrestrial gravity”; (2) “That the apparent daily revolution of the firmament is due to the Earth’s rotation on its own axis”; (3) “That the apparent annual motion of the sun is due to the fact that the Earth, like the other planets, revolves around the sun.”

Since the *Commentariolus* allowed Copernicus to enjoy a certain distinction among various astronomers and intellectuals, he seemed a likely candidate to offer some help in fixing the calendar. Copernicus informed the pope, however, that a further improvement could not be made until the motions of the sun and moon were more precisely coordinated, and thus he declined the pope’s invitation.⁷⁷ Still, various

⁷⁵ In the pre-Christian era, there were two dating systems: (1) a dating system based on the dates of the reigning monarch. In this system, the foundation date is 753 BC, which is the foundation date of Rome under the auspices of Romulus. The Romans titled this foundation date *ab urbe condita* (meaning: “from the foundation of the city”). Their year began on April 21st and they had 355 days in their calendar. This inaccurate calendar remained in force until the time of Julius Caesar, who in 46 BC, under the tutelage of the Greek astronomer Sisogenes, increased the number of days in the year 46 BC to 445. Thereafter (45 BC and onward) there were 365¼ days in the year, and the year would begin on January 1st. (2) a dating system based on the dates of significant events. In this system, the commencement of the Olympic games in 776 BC is the foundation date. Every four years, the Greeks would record the date of the games or “Olympiads,” and the event was abbreviated “OL.” Hence, 1 AD would either be the 754th year of the foundation of Rome, or the fourth year of the 194th Olympiad.

⁷⁶ The full title of the work is: *Nicolai Copernici de hypothesibus motuum coelestium a se constitutes commentariolus*. The exact date of the *Commentariolus* is uncertain, but internal evidence points to the years 1510-1514, thus predating the publication of *De revolutionibus orbium coelestium* by at least three decades. Koestler remarks on the effect of *Commentariolus*: “...the first pebble had fallen into the pond and gradually, in the course of the following years, the ripples spread by rumour and hearsay in the Republic of Letters. This led to the paradoxical result that Canon Koppernigk enjoyed a certain fame, or notoriety, among scholars for some thirty years without publishing anything in print, without teaching at a university or recruiting disciples. It is a unique case in the history of science. The Copernican system spread by evaporation or osmosis, as it were” (*The Sleepwalkers*, p. 149).

⁷⁷ Copernicus was indeed correct concerning the difficulty in coordinating the motions of the sun and moon, but it is also known now that such precision is not needed to coordinate a calendar. Nevertheless, to this day the moon’s orbit remains one of the most complicated of all celestial bodies. As Thomas Kuhn notes: “The moon travels around the ecliptic faster and less steadily than the sun. On the average it completes one

Vatican officials continued to make overtures toward Copernicus. For example, in 1532, the personal secretary of Pope Leo X gave a lecture on the heliocentric system to a chosen audience in the Vatican gardens. Then, in 1535, Cardinal Schönberg, who was very close to Pope Leo, encouraged Copernicus “to communicate your discoveries to the learned world” by publishing the heliocentric theory.⁷⁸

Six years later, in 1541, Copernicus summoned the courage to present his work to the next pope, **Paul III**, at least under the pretext that his work was merely a “hypothetical” model, and that he had no intentions of promoting it as the actual system.⁷⁹ Copernicus records this sequence of events in the Introduction to *De revolutionibus*:

For not many years ago under Leo X when the Lateran Council was considering the question of reforming the Ecclesiastical Calendar, no decision was reached, for the sole reason that the magnitude of the year and the months and the movements of the sun and moon had not yet been measured with sufficient accuracy. From that time on I gave attention to making more exact observations of these things and was encouraged to do so

journey through the zodiac in 27½ days, but the time required for any single journey may differ from the average by as much as 7 hours...Successive new moons may be separated by intervals of either 29 or 30 days, and only a complex mathematical theory, demanding generations of systematic observation and study, can determine the length of a specified future month. Other difficulties derive from the incommensurable lengths of the average lunar and solar cycles” (*The Copernican Revolution*, pp. 46-47). It is also known that the moon drifts tangentially from its orbit about 4cm/year. As such, astronomer Fred Hoyle adds: “The two most striking bodies in the sky, the Sun and Moon, cause difficulties at the outset, even before we come to the planets” (*Nicolaus Copernicus*, p. 53).

⁷⁸ Cited by Koestler in “The Greatest Scandal in Christendom,” *The Critic*, October-November, 1964, p. 16.

⁷⁹ Protestant reformer, Andreas Osiander, who wrote the Introduction to *De revolutionibus* (although he did so anonymously so as to leave room for the inference that Copernicus himself wrote it) and George Rheticus, Copernicus’ Protestant confidant who vigorously sought for the publication of the book against his master’s reticence, had different plans, however. Osiander’s April 20, 1541 letter to Rheticus reveals the ploy: “The Aristotelians and theologians will easily be placated if they are told that several hypotheses can be used to explain the same apparent motions...and eventually they will go over to the opinion of the author” (quoted in Johannes Kepler’s *Apologia Tychonis contra Ursum*, and published in the same’s *Opera Omnia*, ed. Frisch, I, pp. 236-276, cited in Koestler’s, *The Sleepwalkers*, p. 171). Based on a June 1542 letter from T. Forsther to J. Schrad, Koestler reasons that Copernicus knew of Osiander’s Introduction but allowed it to be attributed to himself, and thus it became “the greatest scandal in the history of science” (*ibid.*, p. 169). Koestler concludes: “There is a strangely consistent parallel between Copernicus’ character, and the humble, devious manner in which the Copernican revolution entered through the back door of history, preceded by the apologetic remark: ‘Please don’t take seriously – it is all meant in fun, for mathematicians only, and highly improbable indeed’” (*ibid.*, p. 175).

by that most distinguished man, Paul, Bishop of Fossombrone, who had been present at those deliberations. But what have I accomplished in this matter I leave to the judgment of Your Holiness in particular and to that of all other learned mathematicians.⁸⁰

Despite all the introductory fanfare, *De revolutionibus* was certainly not a smash hit in the annals of book publishing. The first run was a thousand copies, which never sold out. There were only four reprints in the next four hundred years. Compared to other books on astronomy being sold at that time, including [Claudius Ptolemy's](#) *Almagest*, whose reprints were in the hundreds, *De revolutionibus* had one reprint prior to 1700.⁸¹ One reason for its unpopularity was its unreadability. It was choppy, obtuse, and pedantic. The thrust of the theory fills fewer than twenty pages at the beginning of the book, roughly five percent of the whole treatise. When the book reaches its end, there is little left of the original teaching, and thus Copernicus can offer no concluding statement, even though it was promised many times in the text.

Truth be told, the main reason for its unpopularity was that it offered no real improvement over Ptolemy's system. In the Introduction, Copernicus claims to have rid cosmology of Ptolemy's somewhat cumbersome epicyclical system, which had been in use for over a thousand years. To Paul III he writes:

For some make use of homocentric circles only, others of eccentric circles and epicycles, by means of which however they do not fully attain what they seek. For although those who have put their trust in homocentric circles have shown that various different movement can be composed of such circles, nevertheless they have not been able to establish anything for

⁸⁰ *On the Revolutions of Heavenly Spheres*, translated by Charles Glen Wallis, New York: Prometheus Books, 1995, p. 7.

⁸¹ These included Jesuit Christopher Clavius' book *Treatise on the Sphere*, reprinted nineteen times; Philip Melancthon's *Doctrine of Physics*, reprinted seventeen times, which refuted Copernicus' book. Claudius Ptolemaeus' book was originally titled μαθηματικὴ σύνταξις (*Mathematike Syntaxis*) in AD 142 but was renamed by Arab astronomers to *Almagest*, which means "the greatest." As Toomer notes: "It was dominant to an extent and for a length of time which is unsurpassed by any scientific work except Euclid's *Elements*....In the late eighth and ninth centuries, with the growth of interest in Greek science in the Islamic world, the *Almagest* was translated, first into Syriac, then, several times, into Arabic. In the middle of the twelfth century no less than five such versions were still available....Two of these translations are still extant, those of al-Hajjāj and Ishāq-Thābit. In them we find the title of Ptolemy's treatise given as 'al-mjsty'. This is undoubtedly derived...from a Greek form μέγιστη (?sc. σύνταξις), meaning 'greatest [treatise]', but it is only later that it was incorrectly vocalized as al-majastī, whence are derived the mediaeval Latin 'almagesti,' 'almagestum,' the ancestors of the modern title 'Almagest'" (G. J. Toomer, *Ptolemy's Almagest*, London, Gerald Duckworth and Co, 1984, pp. 1-2)

certain that would fully correspond to the phenomena. But even if those who have thought up eccentric circles seem to have been able for the most part to compute the apparent movements numerically by those means, they have in the meanwhile admitted a great deal which seems to contradict the first principles of regularity of movement.⁸²

Theologically speaking, Paul III wasn't bothered by this assertion, since it appeared that Copernicus made no insistence on making the heliocentric model more than an intriguing hypothesis. Unbeknownst to the pope, however, Copernicus' solar system was in many instances more complicated than Ptolemy's. What Copernicus claimed as simplicity is one thing; what his work shows is quite another. Even a cursory reading of *De revolutionibus* reveals that the model he proposed was complicated and tenuous.⁸³ As one author observes:

What we call the Copernican revolution was not made by Canon Koppernigk. His book was not intended to cause a revolution. He knew that much of it was unsound, contrary to evidence, and its basic assumption unprovable.⁸⁴As a result of all this, Canon Koppernigk's lifework seemed to be, for all useful purposes, wasted. From the seafarers' and stargazers' point of view, the Copernican planetary tables were only a slight improvement on the earlier Alphonsine tables, and were soon abandoned. And insofar as the theory of the universe is concerned, the Copernican system, bristling with inconsistencies, anomalies, and arbitrary constructions, was equally unsatisfactory, most of all to himself. In the lucid intervals between the long periods of torpor, the dying Canon must have been painfully aware that he had failed.⁸⁵

⁸² *On the Revolutions of Heavenly Spheres*, p. 5.

⁸³ Some of the things with which Copernicus had to contend are: the obliquity of the ecliptic; the intersection of the equator, ecliptic and meridian; declinations and ascensions of stars; angles of the ecliptic with the horizon; precessions of solstices and equinoxes; irregularities of the equinoctial precession; the magnitude and difference of the solar year; the irregularity of the sun's movement; the changes of the apsides; regular and apparent movement; the moon's very complicated and irregular movement; the unequal apparent diameter of the moon and its parallaxes; the mean oppositions and conjunctions of the sun and moon; ecliptic conjunctions; the irregular movements of the other planets; the latitudes of the planets; the planets' angles of obliquation; and many other issues.

⁸⁴ *The Sleepwalkers*, p. 151. So reticent was Copernicus to publish his work for fear of ridicule that Rheticus, wishing to obscure the true author, published a summary of the contents and attributed the work to "the learned Dr. Nicolas of Torun," the town in which Copernicus was born.

⁸⁵ Arthur Koestler, *The Sleepwalkers*, p. 126.

One of the more obvious faults of *De revolutionibus* was that for all its complaints against ancient epicycles, Copernicus actually produced more epicycles than Ptolemy! Ptolemy's system has forty epicycles, whereas Copernicus ends up with forty-eight. Yet in the earlier work, the *Commentariolus*, Copernicus stated that his heliocentric system needed [only thirty-four epicycles](#), and even this numeration was off by four.⁸⁶ What happened, of course, was that since the *Commentariolus* was merely a preliminary thesis, Copernicus soon discovered that when the time came to work out the finer details of his system a couple of decades later, he was forced to add fourteen more epicycles just to make his version of celestial mechanics come close to the accuracy of Ptolemy's.⁸⁷ As one source puts it: "...recent computer

⁸⁶ Copernicus writes in the *Commentariolus*: "Behold! Only 34 circles are required to explain the entire structure of the universe and the dance of the planets!" (Gingerich, *The Book that Nobody Read*, p. 56). But Koestler remarks: "Incidentally, as Zinner has pointed out, even the famous count at the end of the *Commentariolus* is wrong as Copernicus forgot to account for the precession, the motions of the aphelia and the lunar nodes. Taking these into account, the *Commentariolus* uses thirty-eight not thirty-four circles," adding that Copernicus makes no mention of the total number of epicycles in *De revolutionibus*: "Apart from the erroneous reference to 34 epicycles, I have nowhere see a count made of the number of circles in *De revolutionibus*" (*The Sleepwalkers*, p. 580), perhaps hiding the fact from his reader that it contained more epicycles than the *Commentariolus*. Gingerich adds: "Copernicus must have realized that with his small epicyclets he actually had more circles than the Ptolemaic computational scheme used in the Alfonsine Tables or for the Stoeffler ephemerides" (op. cit., p. 58). Regarding the discrepancies among the orbits of Mars, Jupiter and Saturn in 1504, Gingerich writes: "...the evidence is firm that he had observed the cosmic dance at this time [1504] and was fully aware of the discrepancies in the tables. But what is most astonishing is that Copernicus never mentioned his observation, and his own tables made no improvement in tracking these conjunctions" (ibid., p. 59).

⁸⁷ *The Sleepwalkers*, p. 194-195. One reason Copernicus had so many epicycles is, rather than placing the sun in the center of the universe, he placed the Earth's entire orbit in the center (although, according to Gingerich: "this was an unresolved mystery in the book, for Copernicus hedged on the issue," *The Book that Nobody Read*, p. 163). Koestler remarks that discrepancies in the biographical literature on the number of epicycles in Copernicus' system is due to the fact that most historians have not read Copernicus' book but have depended on other biographers for their information. Koestler's notes show that he did a painstaking analysis of *De revolutionibus* that allows him to conclude Copernicus used forty-eight epicycles (pp. 579-580). Gingerich accounts for these extra epicycles as follows: "While he [Copernicus] had eliminated all of Ptolemy's major epicycles, merging them all into the Earth's orbit, he then introduced a series of little epicyclets to replace the equant, one per planet" (*The Book that Nobody Read*, pp. 54-55). For mistaken scholarly accounts that settled on Copernicus having only 34 epicycles, Koestler cites the *Chamber's Encyclopedia* as stating the Copernican system reduced the epicycles "from eighty to thirty-four," as is the case with Herbert Dingle's address to the *Royal Astronomical Society* in 1943. In my research I found the same discrepancies. Ivars Peterson writes: "Copernicus needed more circles in his sun-centered model than Ptolemy did in his Earth-centered scheme [a] total of 34 circles for all the planets and the moon" (*Newton's Clock: Chaos in the Solar System*, New York: William H. Freeman and Co. 1993, p. 54). Some add even

analyses...have shown the Copernican Prutenic Tables – so named because they were dedicated to the duke of Prussia – to have been scarcely more accurate.”⁸⁸

More disturbing is the fact that, to make Ptolemy’s model appear worse than it really was, Copernicus exaggerated the number of epicycles employed by his ancient rival. Although Ptolemy used only forty epicycles, Copernicus asserted that he had eighty!⁸⁹ This gives us a strong hint that Copernicus was not in this game merely to give the world a better model of cosmology; rather, he thought of it as an historic competition that allowed him to inflate his opponent’s errors.

The complexity of Copernicus’ heliocentric system stems in part from the fact that most of the charts and figures in *De revolutionibus* were not original. Copernicus merely borrowed them from the Greeks and then reworked the figures to fit his heliocentric model:

Canon Koppernigk was not particularly fond of star-gazing. He preferred to rely on the observations of Chaldeans, Greeks, and Arabs – a preference that led to some embarrassing results. *The Book of the Revolutions* contains, altogether, only twenty-seven observations made by the Canon himself; and these were spread over thirty-two years!...Even in the position he assumed for his basic star, the Spica, which he used as a landmark, was erroneous by about forty minutes’ arc, more than the width of the moon.⁹⁰

Alexandrian astronomers can hardly be accused of ignorance. They had more precise instruments for observing the universe than Copernicus had; Copernicus himself hardly bothered with star-gazing; he relied on the observations of Hipparchus and

more epicycles to Copernicus, as is the case with James Burke: “To account for the apparent alterations in speed and movement of the planets, Copernicus was obliged to use as many as ninety Ptolemaic epicycles” (*The Day the Universe Changed*, p. 134).

⁸⁸ Joshua Gilder and Anne-Lee Gilder, *Heavenly Intrigue: Johannes Kepler, Tycho Brahe, and the Murder Behind One of History’s Greatest Scientific Discoveries*, New York: Doubleday, 2004, p. 38.

⁸⁹ Owen Gingerich adds that the myth of having to put up with an inordinate amount of Ptolemaic epicycles perpetuated itself like an out-of-control gossip chain. He writes: “The legend reached its apotheosis when the 1969 *Encyclopedia Britannica* announced that, by the time of King Alfonso, *each planet* required 40 to 60 epicycles! The article concluded, ‘After surviving more than a millennium, the Ptolemaic system failed; its geometrical clockwork had become unbelievably cumbersome and without satisfactory improvements in its effectiveness.’ When I challenged them, the *Britannica* editors replied lamely that the author of the article was no longer living, and they hadn’t the faintest idea if or where any evidence for the epicycles on epicycles could be found” (*The Book that Nobody Read*, pp. 56-57).

⁹⁰ Arthur Koestler, *The Sleepwalkers*, p. 125.

Ptolemy. He knew no more about the actual motions of the stars than they did. Hipparchus' Catalogue of the fixed stars and Ptolemy's Tables for calculating planetary motions were so reliable and precise that they served, with insignificant corrections, as navigational aids to Columbus and Vasco da Gama. Eratosthenes, another Alexandrian, computed the diameter of the Earth as 7,850 miles with an error of only ½ per cent. Hipparchus calculated the distance of the moon as 30¼ Earth diameters – with an error of only 0.3 per cent. Thus, insofar as factual knowledge is concerned, Copernicus was no better off, and in some respects worse off, than the Greek astronomers of Alexandria who lived at the time of Jesus Christ.⁹¹

Along these lines, Thomas Kuhn reveals the modern misconception of Copernicus:

But this apparent economy of the Copernican system, though it is a propaganda victory that the proponents of the new astronomy rarely failed to emphasize, is largely an illusion...The seven-circle system presented in the First Book of the *De revolutionibus*, and in many modern elementary accounts of the Copernican system, is a wonderfully economical system, but it does not work. It will not predict the position of planets with an accuracy comparable to that supplied by Ptolemy's system.⁹²

To drive home the point, Kuhn adds:

...this brief sketch of the complex system of...Copernicus...indicates the third great incongruity of the *De revolutionibus* and the immense irony of Copernicus' lifework. The preface to the *De revolutionibus* opens with a forceful indictment of Ptolemaic astronomy for its inaccuracy, complexity, and inconsistency, yet before Copernicus' text closes, it has convicted itself of exactly the same shortcomings. Copernicus' system is neither simpler nor more accurate than

⁹¹ Arthur Koestler, *The Sleepwalkers*, p. 73. NB: Before the invention of the telescope, an accurate measurement of the distance between the sun and the Earth was not possible. Ptolemy had estimated the distance to be 610 Earth diameters, while Copernicus estimated it to be 571 Earth diameters. The actual distance is 11,500 Earth diameters.

⁹² Thomas S. Kuhn, *The Copernican Revolution: Planetary Astronomy in the Development of Western Thought*, New York: Random House, 1957, 1959, p. 169. N. R. Hanson adds: "...in no ordinary sense of 'simplicity' is the Copernican theory simpler than the Ptolemaic" (*Constellations and Conjectures*, Dordrecht, D. Reidel, 1973. Cited in Imre Lakatos' *The Methodology of Scientific Research Programmes*, p. 175).

Ptolemy's. And the methods that Copernicus employed in constructing it seem just as little likely as the methods of Ptolemy to produce a single consistent solution of the problem of the planets. The *De revolutionibus* itself is not consistent with the single surviving early version of the system, described by Copernicus in the early manuscript *Commentariolus*. Even Copernicus could not derive from his hypothesis a single and unique combination of interlocking circles, and his successors did not do so...Judged on purely practical grounds, Copernicus' new planetary system was a failure; it was neither more accurate nor significantly simpler than its Ptolemaic predecessors.⁹³

[Sir Fred Hoyle](#), one of the better known celestial mechanics of our generation, provides a similar observation:

...the geocentric theory of Ptolemy had proved more successful than the heliocentric of Aristarchus. Until Copernicus, experience was just the other way around. Indeed, Copernicus had to struggle long and hard over many years before he equaled Ptolemy, and in the end the Copernican theory did not greatly surpass that of Ptolemy.⁹⁴

Accordingly, no less a scientific luminary than [Stephen Hawking](#) admits the same:

We now have a tendency to dismiss as primitive the earlier world picture of Aristotle and Ptolemy in which the Earth was at the center and the sun went around it. However we should not be too scornful of their model, which was anything but simple-minded. It incorporated Aristotle's deduction that the Earth is a round ball rather than a flat plate and it was reasonably accurate in its main function, that of predicting the apparent positions of the heavenly bodies in the sky for astrological purposes. In fact, it was about as accurate as the heretical suggestion put forward in 1543 by Copernicus that the Earth and the planets moved in circular orbits around the sun.

⁹³ Thomas S. Kuhn, *The Copernican Revolution: Planetary Astronomy in the Development of Western Thought*, New York: Random House, 1957, 1959, p. 171. Herbert Butterfield adds: "[Copernicus] was puzzled by the variations he had observed in the brightness of the planet Mars...Copernicus' own system was so far from answering to the phenomena in the case of Mars that Galileo in his main work on this subject praises him for clinging to his new theory though it contradicted observation..." (*The Origins of Modern Science: 1300-1800*, New York, The Free Press, 1957, p. 37).

⁹⁴ Fred Hoyle, *Nicolaus Copernicus: An Essay on his Life and Work*, New York: Harper and Row Publishers, 1973, p. 5.

Galileo found Copernicus' proposal convincing not because it better fit the observations of planetary positions but because of its simplicity and elegance, in contrast to the complicated epicycles of the Ptolemaic model. In *Dialogues Concerning Two Sciences*, Galileo's characters, Salviati and Sagredo, put forward persuasive arguments in support of Copernicus. Yet, it was still possible for his third character, Simplicio, to defend Aristotle and Ptolemy and to maintain that in reality the Earth was at rest and the sun went round the Earth.⁹⁵

Even though Hawking betrays the fact that he hasn't thoroughly studied Copernicus' *De revolutionibus* and is thus under the false impression that only Ptolemy, not Copernicus, had "complicated epicycles," still, he reveals the distinct advantage a twentieth-century astronomer possesses over his sixteenth-century counterpart, that is, in the science of kinematics it is possible to make any point in space the center, and subsequently coordinate all of the other bodies around it. As Hoyle notes again:

Let it be understood at the outset that it makes no difference, from the point of view of describing planetary motion, whether we take the Earth or the Sun as the center of the solar system. Since the issue is one of relative motion only, there are infinitely many exactly equivalent descriptions referred to different centers – in principle any point will do, the Moon, Jupiter... So the passions loosed on the world by the publication of Copernicus' book, *De revolutionibus orbium caelestium libri VI*, were logically irrelevant...⁹⁶

In other words, mathematically and relatively speaking, we can make any planet, or even the moon, the center of the solar system, and the geometric proportions will turn out precisely the same as having the sun at the center. He further adds:

...we can take either the Earth or the Sun, or any other point for that matter, as the center of the solar system. This is certainly so for the purely kinematical problem of describing the planetary motions. It is also possible to take any point as

⁹⁵ *On the Shoulders of Giants*, ed., Stephen Hawking, Running Press Book Publishers, Phila., PA, 2002, pp. ix-x.

⁹⁶ Fred Hoyle, *Nicolaus Copernicus: An Essay on his Life and Work*, New York: Harper and Row Publishers, 1973, p. 1. Two years later he wrote: "We know that the difference between a heliocentric theory and a geocentric theory is one of relative motion only, and that such a difference has no physical significance. But such an understanding had to await Einstein's theory of gravitation in order to be fully clarified" (*Astronomy and Cosmology*, 1975, p. 416).

the center even in dynamics, although recognition of this freedom of choice had to await the present century.⁹⁷

Or we can quote other notables who recognize the same principle, for instance, the noted physicist **Max Born**:

...Thus we may return to **Ptolemy's point of view** of a "motionless Earth." This would mean that we use a system of reference rigidly fixed to the Earth in which all stars are performing a rotational motion with the same angular velocity around the Earth's axis...one has to show that the transformed metric can be regarded as produced according to Einstein's field equations, by distant rotating masses. This has been done by Thirring. He calculated a field due to a rotating, hollow, thick-walled sphere and proved that inside the cavity it behaved as though there were centrifugal and other inertial forces usually attributed to absolute space. Thus from Einstein's point of view, Ptolemy and Copernicus are equally right. What point of view is chosen is a matter of expediency.⁹⁸

Martin Gardner, who authored one of the most popular and well-written books on Einstein's theory of Relativity, states quite candidly:

⁹⁷ Fred Hoyle, *Nicolaus Copernicus: An Essay on his Life and Work*, New York: Harper and Row Publishers, 1973, p. 82. Also from the same book: "Today we cannot say that the Copernican theory is "right" and the Ptolemaic theory is "wrong" in any meaningful sense. The two theories are...physically equivalent to one another" (*ibid*, p. 88). Physicist J. L. McCauley who reviewed Hoyle's book stated it was "The only brief account, using understandable modern terminology, of what Ptolemy and Copernicus really did. Epicycles are just data analysis (Fourier series), they don't imply any underlying theory of mechanics. Copernicus did not prove that the Earth moves, he made the equivalent of a coordinate transformation and showed that an Earth-centered system and a sun-centered system describe the data with about the same number of epicycles. For the reader who wants to understand the history of ideas of motion, this is the only book aside from Barbour's far more exhaustive treatment" (Letters on File, 10-1-04).

⁹⁸ Max Born, *Einstein's Theory of Relativity*, New York, Dover Publications, 1962, 1965, pp. 344-345. We will delve much more deeply into Relativity and Hans Thirring's work later in this volume. Nevertheless, being a Copernican at heart, Born has his preference, but not at the cost of logic: "For the mechanics of the planetary system the view of Copernicus is certainly the more convenient. But it is meaningless to call the gravitational fields that occur when a different system of reference is chosen 'fictitious' in contrast with the 'real' fields produced by near masses: it is just as meaningless as the question of the 'real' length of a rod in the special theory of relativity. A gravitational field is neither 'real' nor 'fictitious' in itself. It has no meaning at all independent of the choice of co-ordinates just as in the case of the length of a rod. Nor are the fields distinguished by the fact that some are directly produced by masses while others are not; in the one case it particularly is the near masses that produce an effect; in the other it is the distant masses of the cosmos."

The ancient argument over whether the Earth rotates or the heavens revolve around it (as Aristotle taught) is seen to be no more than an argument over the simplest choice of a frame of reference. Obviously, the most convenient choice is the universe...Nothing except inconvenience prevents us from choosing the Earth as a fixed frame of reference...If we choose to make the Earth our fixed frame of reference, we do not even do violence to everyday speech. We say that the sun rises in the morning, sets in the evening; the Big Dipper revolves around the North Star. Which point of view is “correct”? Do the heavens revolve or does the Earth rotate. The question is meaningless.⁹⁹

In the late 1800s, author and scientist J. L. E. Dreyer adds that the **Earth-centered system** developed in 1583 by **Tycho Brahe** “...is in reality absolutely identical with the system of Copernicus and all computation of the places of the planets are the same for the two systems.”¹⁰⁰ Physicist Hans Reichenbach, contemporary of and firm supporter of Einstein, admits:

...it is very important to acknowledge that the Copernican theory offers a very exact calculation of the apparent movements of the planets...even though it must be conceded that, from the modern standpoint practically identical results could be obtained by means of a somewhat revised Ptolemaic system...It makes no sense, accordingly, to speak of a difference in truth between Copernicus and Ptolemy: both conceptions are equally permissible descriptions. What has been considered as the greatest discovery of occidental wisdom, as opposed to that of antiquity, is questioned as to its truth value.¹⁰¹

⁹⁹ *The Relativity Explosion*, New York, Vintage Books/Random House, 1976, pp. 86-87. The previous edition was published in 1962 under the title: *Relativity for the Million*.

¹⁰⁰ Dreyer, J. L. E., *A History of Astronomy from Thales to Kepler*, New York, Dover Publications reprint, 1953, p. 363. See also his 1890 work *Tycho Brahe*, (New York, Dover Publications reprint, 1963). Modern astronomy admits that the Tychonian planetary model is observationally indistinguishable from the Copernican model, yet in that model the Earth remains absolutely fixed while the universe revolves around the sun, and the sun, in turn, revolves around Earth. For a simulation, please employ the enclosed CD program or visit a similar demonstration on the Internet at: (www.pwr-tools.com/simsolar). It is recommended that one check the boxes for “orbit to scale,” “planets to scale,” and “sun to scale” and run the program with a speed of 0.25. One can then “zoom” in and out to observe various dimensions of the system. Another program of this type can be found at: (<http://jove.geol.niu.edu/faculty/stoddard/JAVA/ptolemy.html>).

¹⁰¹ *From Copernicus to Einstein*, translated by Ralph B. Winn, New York, Dover Publications, 1970, pp, 18, 82.

Lincoln Barnett, another Einstein disciple, is quite honest about science's inability to prove Copernicanism and disprove geocentrism. He writes: "We can't feel our motion through space; nor has any experiment ever proved that the Earth actually is in motion."¹⁰² Henri Poincaré admits: "A great deal of research has been carried out concerning the influence of the Earth's movement. The results were always negative."¹⁰³ Carl E. Wulfman adds: "I tell my classes that had Galileo confronted the Church in Einstein's day, he would have lost the argument for better reasons."¹⁰⁴ Philosopher and scientist **Bertrand Russell** reveals:

Whether the Earth rotates once a day from west to east, as Copernicus taught, or the heavens revolve once a day from east to west, as his predecessors believed, the observable phenomena will be exactly the same. This shows a defect in Newtonian dynamics, since an empirical science ought not to contain a metaphysical assumption, which can never be proved or disproved by observation.¹⁰⁵

Before Copernicus, people thought that the Earth stood still and that the heavens revolved about it once a day. Copernicus taught that 'really' the Earth revolves once a day, and the daily rotation of sun and stars is only 'apparent.' Galileo and Newton endorsed this view, and many things were thought to prove it – for example, the flattening of the Earth at the poles, and the fact that bodies are heavier there than at the equator. But in the modern theory the question between Copernicus and his predecessors is merely one of convenience; all motion is relative, and there is no difference between the two statements: 'the earth rotates once a day' and 'the heavens revolve about the Earth once a day.' The two mean exactly the same thing,

¹⁰² Lincoln Barnett, *The Universe and Dr. Einstein*, New York: New American Library, 1957, p. 73. Albert Einstein wrote the Foreword to Barnett's book, yet while Barnett says in his book that there is no proof to Copernicanism, in Einstein's famous 1905 paper it is stated: "...the same dynamic and optical laws are valid, as this for first-order magnitudes already has been proven," showing that Einstein based Relativity on his belief that Copernicanism was, indeed, a "proven" fact ("Zur Elektrodynamik bewegter Körper," *Annalen der Physik*, Vol. 17, 1905, pp. 891-892). In addition, Barnett's book contains Einstein's following endorsement: "Lincoln Barnett's book represents a valuable contribution to popular scientific writing. The main ideas of the theory of relativity are extremely well presented: Princeton, New Jersey, September 10, 1948."

¹⁰³ Stated in 1901 in *La science et l'hypothèse*, Paris, Flammarion, 1968, p. 182.

¹⁰⁴ Letter from Carl Wufman (University of the Pacific, California) to Peter Wilders, Nov. 2, 1975, cited in "Galileo to Darwin" by Peter Wilders, *Christian Order*, April 1993, p. 225.

¹⁰⁵ Quoted from Dennis W. Sciama's, *The Unity of the Universe*, New York: Doubleday, 1961, p. 102-103.

just as it means the same thing if I say that a certain length is six feet or two yards. Astronomy is easier if we take the sun as fixed than if we take the Earth, just as accounts are easier in decimal coinage. But to say more for Copernicus is to assume absolute motion, which is a fiction. All motion is relative, and it is a mere convention to take one body as at rest. All such conventions are equally legitimate, though not all are equally convenient.¹⁰⁶

Physicist I. Bernard Cohen wrote in 1960:

There is no planetary observation by which we on Earth can prove that the Earth is moving in an orbit around the sun. Thus all Galileo's discoveries with the telescope can be accommodated to the system invented by Tycho Brahe just before Galileo began his observations of the heavens. In this Tychonic system, the planets...move in orbits around the sun, while the sun moves in an orbit around the Earth in a year. Furthermore, the daily rotation of the heavens is communicated to the sun and planets, so that the Earth itself neither rotates nor revolves in an orbit.¹⁰⁷

In the 1930s, physicist Arthur Lynch saw the same truth:

Descartes is, however, doubly interesting to us in the discussion of Relativity, for at one time when the Inquisition was becoming uneasy about his scientific researches, he gave them a reply that satisfied them, or perhaps he merely gained time, which was long, while they were trying to understand its meaning. He declared that the sun went around the Earth, and that when he said that the Earth revolved round the sun that was merely another manner of expressing the same occurrence. I met with this saying first from Henri Poincaré, and I thought then that it was a witty, epigrammatic way of compelling thought to the question; but on reflection I saw that it was a statement of actual fact. The movements of the two bodies are relative one to the other, and it is a matter of choice as to which we take as our place of observation.¹⁰⁸

And once again from the celebrated astronomer, **Fred Hoyle**:

¹⁰⁶ Bertrand Russell, *The ABC of Relativity*, London, revised edition, editor Felix Pirani, New York, Signet Books, New American Library; England, George Allen and Unwin, 1958, pp. 13-14.

¹⁰⁷ I. Bernard Cohen, *Birth of a New Physics*, revised and updated, New York: W. W. Norton, 1985, p. 78.

¹⁰⁸ Arthur Lynch, *The Case Against Einstein*, p. 22.

Tycho Brahe proposed a dualistic scheme, with the Sun going around the Earth but with all other planets going around the Sun, and in making this proposal he thought he was offering something radically different from Copernicus. And in rejecting Tycho's scheme, Kepler obviously thought so too. Yet in principle there is no difference.¹⁰⁹

We know now that the difference between a heliocentric and a geocentric theory is one of motions only, and that such a difference has no physical significance," [the Ptolemaic and Copernican views], "when improved by adding terms involving the square and higher powers of the eccentricities of the planetary orbits, are physically equivalent to one another."¹¹⁰

Even college physics textbooks make it known to their students that geocentrism has not been dethroned. The authors of these texts know the relevance of the question, since virtually every physics book published in the last two centuries begins its lessons by making reference to the debate between the Ptolemaic and Copernican systems. One text puts it this way:

Does the Earth really go around the Sun? Or is it also valid to say that the Sun goes around the Earth? Discuss in view of the first principle of relativity (that there is no best reference frame).¹¹¹

Obviously, in light of the principle of Relativity to which the student was introduced earlier, the above questions are merely rhetorical. The textbook is actually preparing the student for the fact that modern science will no longer allow anyone to lay claim to the Copernican principle, and the text further implies that it has no way of determining which model is correct, the heliocentric or the geocentric. The author, Douglas Giancoli, attempts to reinforce the relativity principle with a

¹⁰⁹ Fred Hoyle, *Nicolaus Copernicus: An Essay on His Life and Work*, New York: Harper and Row, 1973, p. 3. Hoyle continues: "So what was the issue? The issue was to obtain even *one* substantially correct empirical description of the planetary motions. The issue was to find out *how* the planets moved...With knowledgeable hindsight, the situation may not seem unduly complicated, but looked at without foreknowledge the problem of *how* is anything but simple" (emphasis his). In the same book, Hoyle adds a time-lapsed photograph of the motions of the planets as seen from Earth. The photo shows looping motions, zig-zagging motions, abrupt reversal motions, in short, a dizzying array of complexity.

¹¹⁰ The first quote taken from Fred Hoyle's *Astronomy and Cosmology*, San Francisco, W. H. Freeman and Co, 1975, p. 416; the second, from Hoyle's *Nicolaus Copernicus: An Essay on His Life and Work*, p. 88.

¹¹¹ *Physics: Principles with Applications*, fourth edition, Douglas C. Giancoli, New Jersey, Prentice Hall, 1995, p. 767.

discussion of the famous 1887 Michelson-Morley experiment, which, he states: "...was intended to measure the motion of the Earth relative to an absolute reference frame. Its failure to do so implies the absence of any such preferred frame."¹¹² Of course, the alternative he fails to offer his reader is that, in line with his rhetorical question above ("Or is it also valid to say that the Sun goes around the Earth?"), a perfectly valid "implication" of the Michelson-Morley experiment is that *no* "motion of the Earth" exists and, consequently, the Earth itself is the "preferred frame."

Interestingly enough, in the first edition of the same physics textbook, Giancoli freely admitted the geocentric "implications" of the Michelson-Morley experiment:

But this implies that the earth is somehow a preferred object; only with respect to the earth would the speed of light be c as predicted by Maxwell's equations. This is tantamount to assuming that the earth is the central body of the universe.¹¹³

¹¹² *Physics: Principles with Applications*, fifth edition, Douglas C. Giancoli, New Jersey, Prentice Hall, 1998, p. 800.

¹¹³ Douglas C. Giancoli, *Physics: Principles with Applications*, New Jersey, Prentice Hall, 1980, p. 625. Beginning at page 621 and ending with page 625 in the 1980 edition, the text reads: "However, it appeared that Maxwell's equations did not satisfy the relativity principle. They were not the same in all inertial frames. They were simplest in the frame where $c = 3.00 \times 10^8$ m/s; that is, in a reference frame at rest in the ether. In any other reference frame, extra terms would have to be added to take into account the relative velocity. Thus, although most of the laws of physics obeyed the relativity principle, the laws of electricity and magnetism apparently did not. Instead, they seemed to single out one reference frame that was better than any other – a reference frame that could be considered absolutely at rest. Scientists soon set out to determine the speed of the Earth relative to this absolute frame, whatever it might be. A number of clever experiments were designed. The most direct were performed by A. A. Michelson and E. W. Morley in the 1880s. . . Michelson and Morley should have noted a movement in the interference pattern of $(7.0 \times 10^{-16}\text{s})/(1.8 \times 10^{-15}\text{s}) = 0.4$ fringe. They could have easily detected this, since their apparatus was capable of observing a fringe shift as small as 0.01 fringe. But they found no significant fringe shift whatever! They set their apparatus at various orientations. They made observations day and night, so that they would be at various orientations with respect to the sun. They tried at different seasons of the year (the Earth at different locations due to its orbit around the Sun). Never did they observe a significant fringe shift. This "null" result was one of the great puzzles of physics at the end of the nineteenth century. One possibility was that... v would be zero and no fringe shift would be expected. But this implies that the earth is somehow a preferred object; only with respect to the earth would the speed of light be c as predicted by Maxwell's equations. *This is tantamount to assuming that the earth is the central body of the universe.*" The fourth and fifth editions read as follows: "However, it appeared that Maxwell's equations did not satisfy the relativity principle. They were not the same in all inertial frames. They were simplest in the frame where $c = 3.00 \times 10^8$ m/s; that is, in a reference frame at rest in the ether. In any other reference frame, extra terms would have to be added to take into account the relative velocity. Thus, although most of the laws of physics obeyed the relativity principle, the laws of electricity and magnetism apparently did not. Instead, they seemed to single out one reference frame that was better than any other – a reference frame that could be

Perhaps the editors were embarrassed by the devastating alternative and thus felt the need to excise it from future editions; or worse, in order to obscure the true state of affairs regarding the once sacrosanct world of Copernicus, they made a deliberate decision to conceal their previous analysis from the public in hopes that no one would notice the missing words.

In a similar fashion, today's Protestant conservatives who advocate an *ex nihilo* six-day creation but seem to have an aversion to entertaining the possibility of a geocentric universe, admit, nevertheless, that the whole matter is one of perspective, such that heliocentrism is merely a preferred model, but certainly not the proven one. Popular author Jonathan Sarfati writes:

Both sides should have realized that all movement must be described in relation to something else – a reference frame – and from a descriptive point of view, all reference frames are equally valid...Using the sun (or center of mass of the solar system) is the most convenient for discussing planetary motions.¹¹⁴

This very question had troubled the Greeks and Romans over two thousand years ago. Seneca, for example, writes a description very similar to what Born, Hoyle, or Hawking write today, only back then he didn't have anyone to provide him a scientific answer:

It will be proper to discuss this, in order that we may know whether the universe revolves and the Earth stands still, or the universe stands still and the Earth rotates. For there have been

considered absolutely at rest. Scientists soon set out to determine the speed of the Earth relative to this absolute frame, whatever it might be. A number of clever experiments were designed. The most direct were performed by A. A. Michelson and E. W. Morley in the 1880s...Michelson and Morley should have noted a movement in the interference pattern of $(7.0 \times 10^{-16}\text{s}) / (1.8 \times 10^{-15}\text{s}) = 0.4$ fringe. They could have easily detected this, since their apparatus was capable of observing a fringe shift as small as 0.01 fringe. But they found no significant fringe shift whatever! They set their apparatus at various orientations. They made observations day and night, so that they would be at various orientations with respect to the sun. They tried at different seasons of the year (the Earth at different locations due to its orbit around the Sun). Never did they observe a significant fringe shift. This "null" result was one of the great puzzles of physics at the end of the nineteenth century. To explain it was a difficult challenge. One possibility to explain the null result was to apply an idea put forth independently by G. F. Fitzgerald and H. A. Lorentz (in the 1890s) in which they proposed that any length (including the arm of an interferometer) contracts by a factor of $\sqrt{(1-v^2/c^2)}$ in the direction of motion through the ether" (Douglas C. Giancoli, *Physics: Principles with Applications*, fourth edition, pp. 746, 749, and fifth edition, pp. 796, 799).

¹¹⁴ Jonathan Sarfati, "The Sun: Our Special Star," subtitle: "Sunspots, Galileo and Heliocentrism," *Answers in Genesis*, Vol. 22, Issue 1, p. 5.

those who asserted that...risings and settings do not occur by virtue of the motion of the heaven, but that we ourselves rise and set. The subject is worthy of consideration...whether the abode allotted to us is the most slowly or the most quickly moving, whether God moves everything around us or ourselves instead.¹¹⁵

Almost two thousand years later, however, modern science hasn't provided Seneca with a good answer. From Born, Hoyle and Hawking we see that the only response science can give to Seneca is that science doesn't know the answer. In fact, as we will see in this intriguing saga, science has come full circle. It wasn't until the dawn of Relativity (which, as we will see later, was the very physics invented in hopes of saving mankind from having to revert back to geocentrism), that science realized it could never prove heliocentrism, and thus, in every experiment devised since then to show otherwise, science became like Sisyphus pushing the rock up the mountain hoping to reach the summit, only to find that the weight of the evidence could not be overcome, and thus it would be forced to watch the heliocentric rock roll down time after time.

Although many more scientists could be cited, the above quotes give a sufficient across-the-board sampling of the consensus. The irony about the above citations is that they all come from the pens of those who have been classed as heliocentrists. Obviously, then, we can conclude that each scientist will, if he is honest, admit that his advocacy for heliocentrism is merely a preference, and more often a bias, but certainly not the proven system.

¹¹⁵ Seneca, *Nat. Quaest.* vii. 2, 3. Cited in *Aristarchus of Samos: The Ancient Copernicus*, Sir Thomas Heath, Oxford, Clarendon Press, 1913, p. 308.

The Real Truth about Kepler's Solar System

After Copernicus there were, of course, refinements, such as [Johannes Kepler](#)'s elliptical orbits of the planets, which seemed to make things run a bit more smoothly for the heliocentric system. Contrary to popular opinion, however, Kepler's geometrical modification didn't prove Copernicus was right. It merely revealed Kepler's preferences, since he knew that, if the same elliptical modifications were made to the reigning [geocentric model of Tycho Brahe](#), or even to Ptolemy's model, they would have shown heliocentrism to be merely an alternative system, not a superior one. As one physics course puts it: "However, one could also construct a 'Tychoean' model with elliptical orbits."¹¹⁶ In fact, it is well known among historians that although Kepler claimed the discovery of elliptical orbits was supported by independent computations of planetary positions, in actuality he employed the elliptical theory in order to derive his "observations."¹¹⁷ Be that as it may, the ellipses merely helped both the heliocentric and geocentric models to resolve that planetary orbits were not necessarily perfect circles, as opposed to Aristotle's "crystalline spheres" (although some are very close to perfect circles).¹¹⁸

¹¹⁶ University of Illinois, Physics 319, Spring 2004, Lecture 03, p. 11.

¹¹⁷ Knowing this fact, historian Owen Gingerich says that Kepler's ploy "may simply have been a legitimate flourish meant to persuade recalcitrant colleagues of the correctness of his insight" (As cited in the *Bulletin of the Tychoonian Society*, No. 53, 1990, p. 32). Gingerich also suggests that elliptical orbits may not have been the brainchild of Kepler, but of Jerome Schreiber. He writes: "On folio 143 [of Kepler's copy of *De revolutionibus*] there appears the single Greek word *ελλειψις* – that is, ellipse – together with the same sort of emphasis marks that Schreiber used to highlight the passage on folio 96. When I first saw that book in Leipzig, I assumed that it was Kepler who had written *ελλειψις* in the margin, and I hadn't made a color slide of it. Later, when I had discovered more information about the double layer of annotations and the evidence that it was likely Schreiber's handiwork, I had to worry about which one wrote it. ... Eventually I obtained excellent transparencies, which left no doubt that it was indeed Schreiber's ink in the book Kepler had inherited" (*The Book that Nobody Read*, p. 165).

¹¹⁸ Interestingly enough, Kepler was not the first to introduce elliptical orbits of the planets. That honor belongs to the Greeks. As Koestler notes: "There exist some fragmentary remains, dating from the first century AD, of a small-sized Greek planetarium – a mechanical model designed to reproduce the motions of sun, moon, and perhaps also of the planets. But its wheels, or at least some of them, are not circular – they are egg-shaped [footnote: Ernst Zinner, *Entstehung und Ausbreitung der Copernicanischen Lehre* (Erlangen, 1943), p. 48]. Gingerich adds: "The equant got Ptolemy into a lot of trouble as far as many of his successors were concerned. It wasn't that his model didn't predict the angular positions satisfactorily. Rather, the equant forced the epicycle to move nonuniformly around the deferent circle, and that was somehow seen as a deviation from the pure principle of uniform circular motion. Ptolemy himself was apologetic about it, but he used it because it generated the motion that was observed in the heavens. Altogether his system was admirably simple

Even after Kepler's modifications, anomalies regarding the motions of the heavenly bodies remained, and stubbornly so. Although geometrically speaking the orbits are not perfect circles, they are not perfect ellipses either, but precess at different rates and contain various eccentricities. Quoting Hoyle again:

The planetary orbits are not strictly ellipses, as we have so far taken them to be, because one planet disturbs the order of another through the gravitational force that it exerts.... In all cases the orbits are nearly circles.... It is curious that although the actual orbits do not differ in shape much from circles the errors of a circular model can nevertheless be quite large. Indeed, errors as large as this were quite unacceptable to Greek astronomers of the stature of Hipparchus and Ptolemy. It was this, rather than prejudice, which caused them to reject the simply heliocentric theory of Aristarchus.... The Hipparchus theory grapples with the facts whereas the circular picture of Aristarchus fails to do so.... The theory of Ptolemy, a few minor imperfections apart, worked correctly to the first order in explaining the planetary eccentricities. Copernicus with his heliocentric theory had to do at least as well as this, which meant that he had to produce something much better than the simple heliocentric picture of Aristarchus.... Kepler achieved improvements, but not complete success, and always at the expense of increasing complexity. Kepler and his successors might well have gone on in this style for generations without arriving at a satisfactory final solution, for a reason we now understand clearly. There is no simple mathematical expression for the way in which the direction of a planet – its heliocentric longitude – changes with time. Even today we must express the longitude as an infinite series of terms when we use time as the free variable. What Ptolemy, Copernicus, and Kepler, in his early long calculations, were trying to do was to discover by trial and error the terms of this series. Since the terms become more complicated as one goes to higher orders in the eccentricity, the task became successively harder and harder...¹¹⁹

Professor of celestial mechanics at Columbia University, Charles Lane Poor, says the same:

From the time of Newton, it has been known that Kepler's laws are mere approximations, computer's fictions, handy

considering the apparent complexity and variety of the retrograde loops" (*The Book that Nobody Read*, p. 53).

¹¹⁹ Fred Hoyle, *Nicolaus Copernicus: An Essay on his Life and Work*, New York: Harper and Row Publishers, 1973, pp. 73, 8, 9, 53, 11-12, 13-14, in the order of my ellipses.

mathematical devices for finding the approximate place of a planet in the heavens. They apply with greater accuracy to some planets than to others. Jupiter and Saturn show the greatest deviations from strictly elliptical motion. The latter body is often nearly a degree away from the place it would have been had its motion about the sun been strictly in accord with Kepler's laws. This is such a large discrepancy that it can be detected by the unaided eye. The moon is approximately half a degree in diameter, so that the discrepancy in the motion of Saturn is about twice the apparent diameter of the moon. In a single year, during the course of one revolution about the sun, the Earth may depart from the theoretical ellipse by an amount sufficient to appreciably change the apparent place of the sun in the heavens.¹²⁰

Expanding on Hoyle and Poor's argument, it is clear from the historical record that heliocentric cosmology has been built upon the myth of "simplicity," or what is often referred to in science disciplines as "Occam's razor," that is, "the simplest solution is the best solution."¹²¹ It was the same logic employed in Galileo's time to promote the heliocentric system, with such clichés as: "*natura simplicitatem amat*" (nature loves simplicity); "*natura semper quod potest per faciliora, non agit per ambages difficiles*" (nature always decides to go through the easy path, it does not seek difficult paths). In 1674, the famous scientist [Robert Hooke](#) (contemporary of Newton), in his book *An Attempt to Prove the Motion of the Earth from Observation*, admitted he could not show the Earth was moving in space. He gave two rationalizations for his failure. In the first he claimed it was more or less a psychological problem:

[The Earth's mobility] hath much exercised the Wits of our best modern Astronomers and Philosophers, amongst which notwithstanding there hath not been any one who hath found out a certain manifestation either of the one or the other Doctrine...[Some] have been instructed in the Ptolemaik or Tichonick System, and by the Authority of their Tutors, over-

¹²⁰ Charles Lane Poor, *Gravitation versus Relativity*, p. 129. Astrophysicist and historian, Owen Gingerich adds: "Naturally astronomy textbooks don't show it this way, because they can't make the point about ellipses unless they enormously exaggerate the eccentricity of the ellipse. So for centuries, beginning with Kepler himself, a false impression has been created about the elliptical shape of planetary orbits. The eccentricity of planetary orbits (that is, their off-centeredness) is quite noticeable – even Ptolemy had to copy with that – but the ellipticity (the degree the figure bows in at the sides) is very subtle indeed. Observations of Mars must be accurate to a few minutes of arc for this tiny ellipticity to reveal itself" (*The Book that Nobody Read*, p. 166).

¹²¹ From the writings of William of Occam (1300-1349) who stated: "Essentia non sunt multiplicanda praeter necessitatem."

awed into a belief, if not a veneration thereof: Whence for the most part such persons will not indure to hear Arguments against it, and if they do, 'tis only to find Answers to confute them.¹²²

In the second he tries to settle the issue by an appeal to Occam's razor, but in the end, Hooke himself sees the fallacy of such an approach:

On the other side, some out of a contradicting nature to their Tutors; others, by as great a prejudice of institution; and some few others upon better reasoned grounds, from the proportion and harmony of the World, cannot but embrace the Copernican Arguments.

[But] what way of demonstration have we that the frame and constitution of the World is so harmonious according to our notion of its harmony, as we suppose? Is there not a possibility that things may be otherwise? Nay, is there not something of a probability? May not the Sun move as Ticho supposes, and that the Planets make their Revolutions about it whilst the Earth stands still, and by its magnetism attracts the Sun and so keeps him moving about it?¹²³

The pretentious appeal to Occam has never subsided. When, because of his presupposition toward Relativity, physicist and mathematician [Henri Poincaré](#) was faced with the question of whether the Earth rotated within fixed stars or the stars rotated around a fixed Earth, his only recourse was to assert that the former should be accepted because it enables us to devise a simpler mathematical theory of astronomy.¹²⁴ But the reality is, not only is the dependence on simplicity an unproven assumption, the heliocentric system is not any simpler than the geocentric system. As Imre Lakatos admits:

The superior simplicity of the Copernican theory was just as much of a myth as its superior accuracy. The myth of superior simplicity was dispelled by the careful and professional work

¹²² Robert Hooke, *An Attempt to Prove the Motion of the Earth from Observations*, London, 1674, pp. 1, 3, as cited in Owen Gingerich's St. Edmunds lecture, "Empirical Proof and/or Persuasion," March 13, 2003.

¹²³ Robert Hooke, *An Attempt to Prove the Motion of the Earth from Observations*, London, 1674, pp. 1, 3, as cited in Owen Gingerich's St. Edmunds lecture, "Empirical Proof and/or Persuasion," March 13, 2003.

¹²⁴ As summarized by Morris Kline in *Mathematics: The Loss of Certainty*, Oxford University Press, reprint, 1982, p. 344. Kline himself goes on to argue: "And in fact simplicity of the mathematical theory was the only argument Copernicus and Kepler could advance in favor of their heliocentric theory as opposed to the older Ptolemaic theory."

of modern historians. They reminded us that while Copernican theory solves certain problems in a simpler way than does the Ptolemaic one, the price of the simplification is unexpected complications in the solution of other problems. The Copernican system is certainly simpler since it dispenses with equants and some eccentrics; but each equant and eccentric removed has to be replaced by new epicycles and epicyclets...he also has to put the center of the universe not at the Sun, as he originally intended, but at an empty point fairly near to it....I think it is fair to say that the ‘simplicity balance’ between Ptolemy’s and Copernicus’ system is roughly even.¹²⁵

In fact, considering how mathematically complex the motions of the celestial bodies really are (e.g., the complex motions of the sun and moon cited earlier; Newton’s “three-body” problem and the “perturbations” of the planets, all requiring the use of complex differential and integral calculus to chart their motions), no cosmological system should base its appeal on the simplicity of its system, for in the case of celestial motion, modern science has actually found that if the solution is too simple it is probably wrong, for it means that it isn’t taking everything into account.¹²⁶

Even more revealing is the fact that, as modern science prides itself on having dispensed with Ptolemy’s epicycles, conceptually speaking they are still very much in use, although they are labeled with

¹²⁵ Imre Lakatos, *The Methodology of Scientific Research Programmes: Philosophical Papers*, edited by J. Worrall and G. Currie, Vol. 1, Cambridge University Press, 1978, 1999, pp. 173-174. He adds: “Koestler correctly points out that only Galileo created the myth that the Copernican theory was simple [*The Sleepwalkers*, p. 476]; in fact, [quoting J. L. E. Dreyer, 1906, chapter xiii] ‘the motion of the Earth had not done much to simplify the old theories, for though the objectionable equants had disappeared, the system was still bristling with auxiliary circles’” (*ibid.*, p. 33); “The Copernican revolution was generally taken to be the paradigm of *conventionalist historiography*, and it is still so regarded in many quarters. For instance Polanyi tells us that Copernicus’s ‘simpler picture’ had ‘striking beauty’ and ‘justly carried great powers of conviction’ [M. Polanyi, *The Logic of Liberty*, 1951, p. 70]. But modern study of primary sources, particularly by Kuhn [*The Copernican Revolution*, 1957], has dispelled this myth and presented a clear-cut historiographical refutation of the conventionalist account. It is now agreed that the Copernican system was ‘at least as complex as the Ptolemaic’ [I. Bernard Cohen, *The Birth of a New Physics*, p. 61]. But if this is so, then, if the acceptance of Copernican theory was rational, it was not for its superlative objective simplicity” (Lakatos, *Methodology*, p. 129).

¹²⁶ Philosopher of science Mario Bunge has shown how presumptuous and naïve it is to assume that the scientifically correct solution always turns out to be the least complex (*The Myth of Simplicity*, Englewood Cliffs, New Jersey: Prentice Hall, 1963). Regarding the three-body problem, Lagrange offered a partial solution by assuming one of the three bodies had negligible mass. If a small mass is placed at a *Lagrangian Point*, it will remain stationary in the rotating system. In 1912, K. F. Sundman attempted a solution based on a converging infinite series, but it converges much too slowly to be of any practical use. As it stands, no method has been developed to solve the equations of motion for a system with four or more bodies.

different names in order to conceal their identity. Charles Lane Poor revealed this secret back in the 1920s:

The deviations from the “ideal” in the elements of a planet’s orbit are called “perturbations” or “variations”.... In calculating the perturbations, the mathematician is forced to adopt the old device of Hipparchus, the discredited and discarded epicycle. It is true that the name, epicycle, is no longer used, and that one may hunt in vain through astronomical text-books for the slightest hint of the present day use of this device, which in the popular mind is connected with absurd and fantastic theories. The physicist and the mathematician now speak of harmonic motion, of Fourier’s series, of the development of a function into a series of sines and cosines. The name has been changed, but the essentials of the device remain. And the essential, the fundamental point of the device, under whatever name is may be concealed, is the representation of an irregular motion as the combination of a number of simple, uniform circular motions.¹²⁷

In essence, Poor tells us that the introduction of the Fourier series, invented by [Jean Baptiste Joseph Fourier](#) (d. 1830),¹²⁸ takes the veil off the Copernican system and re-establishes geocentrism to its rightful place. The Fourier series plainly shows that any cosmological system can be demonstrated within reasonable accuracy simply by introducing the proper amount of cyclical modulations (or “circular arguments,” if you will, including, as we will see, the “curved space” of General Relativity). In other words, one can create any mathematical system and then “curve-fit” any deviations or discrepancies back into the system. In the end, Fourier inadvertently exposed the shaky foundations of modern cosmology by showing that there is simply no possibility of being certain about the coordinates of any rotating system, since the math and geometry can be manipulated to fit the observations. In fact, based on Fourier analysis one could design a universe that is constructed from the foundation of a flat Earth (as we see in a two-dimensional map)

¹²⁷ Charles Lane Poor, *Gravitation versus Relativity*, New York: G. P. Putnam’s Sons, Knickerbocker Press, 1922, p. 132. See also Robert W. Brehme, “A New Look at the Ptolemaic System,” *American Journal of Physics*, 44:506-514, 1976. Brehme examines in detail the Ptolemaic system of planetary motions in order to demonstrate its direct kinematical connection with a heliocentric system. Ptolemy’s planetary parameters are shown to be in good agreement, upon transformation, with modern values. See also Bina Chatterjee, “Geometrical Interpretation of the Motion of the Sun, Moon and the Five Planets as Found in the Mathematical Syntaxis of Ptolemy and in the Hindu Astronomical Works,” *Journal of the Royal Asiatic Society of Bengal*, 15:41-88, 1947.

¹²⁸ Joseph B. J. Fourier, *Théorie analytique de la chaleur* [The Analytic Theory of Heat], 1822.

and make it mathematically indistinguishable from one based on a spherical Earth. Math works wonders, but it doesn't provide us with the knowledge of how the actual physical system work. As Poor notes:

No more did Hipparchus believe that the bodies of the solar system were actually attached to the radial arms of his epicycles; his was a mere mathematical, or graphical device for representing irregular, complicated motions. While the graphical, or mechanical method is limited to a few terms, the trigonometrical, or analytical method is unlimited. It is possible to pile epicycle upon epicycle, the number being limited only by the patience of the mathematician and computer. The expressions for the disturbing action of one planet upon another, due the attraction of gravitation, involve an unlimited number of such terms; or, as the mathematician puts it, the series is infinite.¹²⁹

Koestler adds:

The Copernican system is not a discovery...but a last attempt to patch up an out-dated machinery by reversing the arrangement of its wheels. As a modern historian put it, the fact that the Earth moves is "almost an incidental matter in the system of Copernicus which, viewed geometrically, is just the old Ptolemaic pattern of the skies, with one or two wheels interchanged and one or two of them taken out."¹³⁰

¹²⁹ Charles Lane Poor, *Gravitation versus Relativity*, p. 139. In practical terms, Fourier analysis, or harmonic motion, amounts to employing the use of as many circles of motion as needed in order to create the path that coincides most accurately with the actual path of the planet. Astronomer George Abell adds another insight: "Quite likely, however, the spheres of Eudoxus and Callippus were intended as a mere mathematical representation of the motions of the planets. It was a scheme that 'saved the phenomena' better than ones before it, and in this respect it was successful. The epicycles of Ptolemy, developed later, may similarly be regarded as mathematical representations not intended to describe reality. Modern science does no more. The laws of nature 'discovered' by science are merely mathematical or mechanical models that describe how nature behaves, not why, nor what nature 'actually' is" (*Exploration of the Universe*, New York, Holt, Rinehart and Winston, 1969, p. 16).

¹³⁰ *The Sleepwalkers*, pp. 214-215.

What Was the Attraction to the Copernican System?

All this evidence provokes the question as to how the [Copernican system](#) gained such popularity. How is it that a treatise riddled with geometrical and mathematical presumptions, in addition to being one of the less-popular and least-studied books of its day, became the world's most sacrosanct "fact" of existence? Koestler offers at least one plausible answer, one very similar to that with which we opened this chapter:

The answer is that the details did not matter, and that it was not necessary to read the book to grasp its essence. Ideas which have the power to alter the habits of human thought do not act on the conscious mind alone; they seep through to those deeper strata which are indifferent to logical contradictions. They influence not some specific concept, but the total outlook of the mind. The heliocentric idea of the universe, crystallized into a system by Copernicus, and restated in modern form by Kepler, altered the climate of thought not by what it expressly stated, but by what it implied...¹³¹

¹³¹ *The Sleepwalkers*, p. 218. Kepler was the first astronomer to publicly endorse Copernicus. Koestler adds: "The *Mysterium*...the first chapter, which is an enthusiastic and lucid profession of faith in Copernicus. It was the first unequivocal, public commitment by a professional astronomer which appeared in print fifty years after Canon Koppernigk's death...Galileo...and astronomers like Maestlin, were still either silent on Copernicus, or agreed with him only in cautious privacy" (*ibid.*, p. 255). Yet he found out quickly the muddle of Copernicus' figures. Kepler writes: "How human Copernicus himself was in adopting figures which within certain limits accorded with his wishes and served his purpose...He selects observations from Ptolemy, Walter, and others with a view to making his computations easier, and he does not scruple to neglect or to alter occasional hours in observed time and quarter degrees of angle" (*Mysterium Cosmographicum*, Gesammelte Werke, vol. I, note 8). Owen Gingerich takes a different view, claiming that *De revolutionibus* was more popular than Koestler admits. Having found a marked copy of the technical parts of Copernicus' book among the effects of Erasmus Reinhold, Gingerich was prompted to do a worldwide search for evidence of who, precisely, possessed an original edition of *De revolutionibus*, leading him to conclude: "I found copies owned by saints, heretics, and scoundrels, by musicians, movie stars, medicine men, and bibliomaniacs. But most interesting are the exemplars once owned and annotated by astronomers." Gingerich's findings amount to "six hundred printed copies of Copernicus' magnum opus," which coincides with the fact that the first edition was only a thousand copies (*The Book Nobody Read: Chasing the Revolutions of Nicolaus Copernicus*, Owen Gingerich, New York: Walker and Co., 2004, pp. ix-x). Gingerich adds: "Clearly, when Arthur Koestler wrote that *De revolutionibus* was 'the book that nobody read' and 'an all time worst seller,' he couldn't have been more mistaken. He was wrong. Dead wrong" (*ibid.*, p. 255). Gingerich, however, has the tendency throughout his book to insulate Copernicus and his work from negative criticism. Moreover, Koestler's thesis is not based on the number of people who possessed copies of Copernicus' book, but on the number who actually read it completely and did a thorough study of its contents. In that sense, Gingerich does not prove his point against Koestler.

As we opened this chapter with Gould's bold proclamation that modern science has founded itself upon a non-centered, infinite universe, so the same rationale had been employed in previous eras. As Solomon said, "There is nothing new under the sun" – a statement which we can now take both literally and figuratively. The theological, philosophical, social, and intellectual fabric of history has been divided right down the middle by those who have taken one side or the other in the on-going debate as to what revolves around what; a debate that stretches as far back as written records take us. Long before Galileo met his match with the Catholic Church, it was the Babylonians versus the Hebrews, the former advocating the sun-centered model, the latter the Earth-centered system of the Pentateuch.¹³² By the time of the Greeks, it was the Pythagorean school of heliocentrists: [Plato](#), Philolaus, Pliny, Aristarchus, and Seleucus versus the geocentric school of [Aristotle](#), Hipparchus, Theon of Smyrna, Appolonius and [Ptolemy](#).¹³³ Even the Latin geocentrists, unbeknownst to them because no one had translated his works, were in competition with the Indian astronomer Aryabhata who had advocated a heliocentric system.

In the second millennium AD, the drama played itself out much faster since the invention of the printing press made it possible to publish one's views far and wide. Moreover, the arguments on either side became more technical and refined. On this stage the next combatants were the Scholastic astronomers who brought their intellectual muscle against Nicolaus of Cusa and Nicolaus Copernicus. Then, of course, there was Johannes Kepler versus Tycho Brahe, and then Galileo Galilei versus Robert Cardinal Bellarmine, and Isaac Newton versus the Jesuits

¹³² As Tycho Brahe said to Jewish astronomer David Gans: "Your sages were wrong to submit to the non-Jewish scholars. They assented to a lie for the truth lay with the Jewish sages." (André Neher, *Jewish Thought and the Scientific Revolution of the Sixteenth Century: David Gans (1541-1613) and His Times*, translated from the French by David Maisel, Oxford University Press, 1986, p. 218). Moreover, the Babylonians were avid astronomers who believed that the sun god controlled the world, and naturally the sun occupied the center of the universe. Hipparchus is known to have published a star catalogue taken from the Babylonians but written as if it were made from his own observations (See G. J. Toomer, "Ptolemy," *Dictionary of Scientific Biography*, NY: Charles Scribner and Sons, 1975, p. 191).

¹³³ Other Greeks include: Anaximander (580), who held to a central Earth surrounded by spherical heavens; Parmenides (450) held to a central Earth with evenly spaced concentric spheres surrounding it; Xenophanes (550) held to a central Earth and stars that moved rectilinearly; Empedocles (450) also held to a central Earth but an infinite universe; whereas Hiketas (450) Heraklides (350) and Ekphantus (450) held that the Earth rotates in a non-moving heavens. See J. L. E. Dreyer, *A History of Astronomy from Thales to Kepler*, New York, Dover Publications; originally under the 1905 title: *History of Planetary Systems from Thales to Kepler*, Dublin, Ireland; Olaf Pederson, *A Survey of the Almagest*, Odense, Denmark, Odense University Press, 1974; Pierre Dunhem, *To Save the Phenomena: An Essay on the Idea of Physical Theory from Plato to Galileo*, University of Chicago Press, 1969.

and Dominicans,¹³⁴ and James Bradley versus George Airy’s “failure.” After this, geocentrism had a new challenger, the Relativity of Albert Einstein, which, faced with experiments by Albert Michelson and Edward Morley that demonstrated the distinct possibility of a motionless Earth, sought to win the battle of the cosmos by decentralizing the whole universe, since the very idea of having to return to geocentrism was “unthinkable.”¹³⁵

As we saw earlier, Einstein himself concluded: “The struggle, so violent in the early days of science, between the views of Ptolemy and Copernicus would then be quite meaningless. Either... could be used with equal justification.”¹³⁶ A fair question to ask in light of Einstein’s remarkable admission of the viability of geocentric cosmology is: how many people have been enlightened to this knowledge? The answer is: hardly anyone. They have been duly shrouded from the implications of Relativity theory by a campaign engineered like no other in history. The evidence, as we have seen, is just dripping from the textbooks, but very few have been forthright enough to advertise it. Einstein’s contemporary and a world-renowned physicist in his own right, [Willem de Sitter](#), admitted much the same: “The difference between the system of Ptolemy and that of Copernicus is a purely formal one, a difference of interpretation only.”¹³⁷ **Ernst Mach**, who more or less was the pioneer in

¹³⁴ Dorothy Stimson lists the advocates and dissidents of the Copernican theory as catalogued by Giovanni Riccioli, SJ, who held that there were “40 new arguments in behalf of Copernicus and 77 against him.” The list is as follows: Those advocating heliocentrism were: Copernicus, Rheticus, Mæstlin, Kepler, Rothman, Galileo, Gilbert, Foscarini, Didacus Stunica, Ismael Bullialdus, Jacob Lansberg, Peter Herigonius, Gassendi (“but submits his intellect captive to the Church decrees”), Descartes (“inclines to this belief”), A. L. Politianus, Bruno. Those disavowing heliocentrism were: Aristotle, Ptolemy, Theon the Alexandrine, Regiomontanus, Alfraganus, Macrobius, Cleomedes, Petrus Aliacensis, George Buchanan, Maurolycus, Clavius, Barocius, Michael Neander, Telesius, Martinengus, Justus-Lipsius, Scheiner, Tycho, Tasso, Scipio Claramontius, Michael Incofer, Fromundus, Jacob Ascarisius, Julius Cæsar La Galla, Tanner, Bartholomæus Amicus, Antonio Rocce, Marinus Mersennius, Polacco, Kircher, Spinella, Pineda, Lorinis, Mastrius, Bellutris, Poncius, Delphinus, Elephantutius (*The Gradual Acceptance of the Copernican Theory of the Universe*, p. 81-82). Jean Buridan (1300-1358) had once entertained the possibility of a heliocentric system based on its reciprocity with the geocentric, but opted to reject it in favor of Aristotle. Others not on Riccioli’s list who advocated geocentrism are: Francis Bacon, Feyens, Froidmont, Gerogius Agricola, Johann Henrich Voight, Tacquet, Cassini.

¹³⁵ “Unthinkable” is the word employed by Einstein’s biographer Ronald W. Clark to describe Einstein’s reaction to the famous 1887 Michelson-Morley experiment, which, to the consternation of its scientists, offered as one solution to its puzzling results that the Earth was not moving in space (*Einstein: The Life and Times*, p. 110).

¹³⁶ *The Evolution of Physics: From Early Concepts to Relativity and Quanta*, Albert Einstein and Leopold Infeld, New York, Simon and Schuster, 1938, 1966, p. 212.

¹³⁷ Willem de Sitter, *Kosmos*, Cambridge, Harvard University Press, 1932, p. 17.

taking Newtonian relativity to its logical conclusion, stated it quite plainly:

Obviously it matters little if we think of the Earth as turning about on its axis, or if we view it at rest while the fixed stars revolve around it. Geometrically these are exactly the same case of a relative rotation of the Earth and the fixed stars with respect to one another.¹³⁸

All masses, all velocities, thus all forces are relative. There is no basis for us to decide between relative and absolute motion....If there are still modern authors who, through the Newtonian water bucket arguments, allow themselves to be misled into differentiating between relative and absolute motion, they fail to take into account that the world system has been given to us only once, but the Ptolemaic and Copernican views are only our interpretations, but both equally true.¹³⁹

Gerald Holton and Stephen Brush, two well-known physicists, agree with the consensus:

To us it is clear, although it did not enter the argument then, that the scientific content of both theories [Ptolemy's and Copernicus'], the power of prediction of planetary motion, was about the same at that time.... In our modern terminology we would say...that the rival systems differed mainly in the choice of the coordinate system used to describe the observed movements.¹⁴⁰

¹³⁸ Ernst Mach, *Die Mechanik in Ihrer Entwicklung Historisch-Kritisch Dargestellt*, Leipzig: Brokhaus, 1883. English title: *The Science of Mechanics: A Critical and Historical Account of its Development*, translated by T. J. Macormack, La Salle, Open Court Publishing, 1960, 6th edition, p. 201. The seventh edition of Mach's book was published in 1912. Although in this treatise Mach does not himself adopt geocentrism, he repeatedly challenges modern science with the fact that geocentrism is not only a viable alternative, but that a fixed-Earth cosmology substantially answers the famous 1887 Michelson-Morley experiment.

¹³⁹ Ernst Mach, *Die Mechanik in Ihrer Entwicklung Historisch-Kritisch Dargestellt*, Leipzig: Brokhaus, 1883, p. 222. The original German reads: "Alle Massen, alle Geschwindigkeiten, demnach alle Kräfte sind relativ. Es gibt keine Entscheidung über Relatives und Absolutes, welche wir treffen könnten, zu welcher wir gedrängt wären....Wenn noch immer moderne Autoren durch die Newtonschen, vom Wassergefäß hergenommenen Argumente sich verleiten lassen, zwischen relativer und absoluter Bewegung zu unterscheiden, so bedenken sie nicht, daß das Weltsystem uns nur einmal gegeben, die ptolemäische oder kopernikanische Auffassung aber unsere Interpretationen, aber beide gleich wirklich sind" (Translated by Mario Dierksen). NB: Although Mach forbids modern Copernican science from making any distinctions, he cannot forbid the same to Geocentric science, for it is upon divine revelation that the distinction is made, that is, the Earth is motionless and our absolute rest frame.

Holton admitted the same in another book with two other physicists, showing how practical a geocentric system really is:

Copernicus and those who followed him felt that the heliocentric system was right in some absolute sense – that the sun was really fixed in space...But the modern attitude is that the choice of a frame of reference depends mainly on which frame will allow the simplest discussion of the problem being studied. We should not speak of a reference system being right or wrong, but rather as being convenient or inconvenient. (To this day, navigators use a geocentric model for their calculations.)¹⁴¹

In addition to contemplating the numerous quotes we have cited from qualified scientists who have concluded that there is no superiority of the heliocentric system over the geocentric system, the layman can afford himself the opportunity to come to the same conclusion by means of a simple mechanical device. If the opportunity affords itself, make a visit to the nearest planetarium. Inside, one will find what astronomers know as an orrery. An orrery, named after the Earl of Orrery, is a moving mechanical model of the sun and planets. Since almost all orreries are heliocentric models, the sun will be placed in the center and all the planets will be revolving around the sun in their proportionate sizes and speeds. Holding the sun stationary in hand, one can watch all the other planets revolve around it. But with a repositioning of one's hand, the same orrery will demonstrate the geocentric system. Instead of holding the sun, hold the Earth. One will now see the sun and the planets **revolve around the Earth**, *and they will do so in precisely the same relation to one another as when the sun was held in the center*. If one cannot locate an orrery, simply draw a heliocentric model of the sun and planets on a piece of paper and place the point of the pencil in the middle of the sun and then rotate the paper. This will simulate the planets revolving around the sun (as we imagine them in their own paces). But now, put the pencil in the middle of the Earth and rotate the paper. One will discover that the only difference between the two models is that the sun will assume the orbit the Earth had.¹⁴² As one astronomer remarked:

¹⁴⁰ Gerald Holton and Stephen G. Brush, *Introduction to Concepts and Theories in Physical Science*, Reading, MA, Addison-Wesley Publishing Co., 1973, p. 28.

¹⁴¹ James F. Rutherford, Gerald Holton and Fletcher G. Watson, *The Project Physics Course*, New York, Holt, Rinehart and Winston, Inc., 1970, Unit, p. 40.

¹⁴² One can also consult Henry C. King's *Geared to the Stars: The Evolution of Planetariums, Orreries and Astronomical Clocks*, University of Toronto Press, 1978, pp. 442. King shows both geocentric and heliocentric orreries in use beginning from 1650.

“The equivalence of these two pictures was already known to Apollonius, who lived in the third century, BC, long before Ptolemy (ca. AD 150).”¹⁴³ Or, as Thomas Kuhn has noted about the above demonstration:

Now imagine that...the whole mechanism is picked up...and put down again with the sun fixed at the central position formerly held by the Earth...All of the geometric spatial relations of the Earth, sun and Mars...are preserved...and since only the fixed point of the mechanism has been changed, all the relative motions must be identical...the Tychonic system is transformed to the Copernican system simply by holding the sun fixed instead of the Earth. The relative motion of the planets are the same in both systems, and the harmonies are therefore preserved.¹⁴⁴

Ironically, the very theory that was invented to escape geocentrism, Relativity, is now the one that gives it *carte blanche* privileges. Honest scientists admit these facts. Once again, [Fred Hoyle](#), one of the more outspoken and candid astronomers of the twentieth century, is unafraid to cross the scientific picket line and admit the errors and shortcomings of his own field of endeavor. He writes:

We might hope therefore that the Einstein theory, which is well suited to such problems, would throw more light on the matter. But instead of adding further support to the heliocentric picture of the planetary motions, the Einstein theory goes in the opposite direction, giving increased respectability to the geocentric picture. The relation of the two pictures is reduced to a mere coordinate transformation, and it is the main tenet of the Einstein theory that any two ways of looking at the world which are related to each other by a coordinate transformation are entirely equivalent from a physical point of view.¹⁴⁵

Science writer Kitty Ferguson goes one step farther:

Fred Hoyle has argued that a subtler understanding of Einstein’s theories reveals they may actually slightly favor an Earth-centered model. Had Galileo had Hoyle at his elbow, he

¹⁴³ Fred Hoyle, *Nicolaus Copernicus*, New York: Harper and Row, 1973, p. 63.

¹⁴⁴ Thomas S. Kuhn, *The Copernican Revolution*, New York, Random House, 1959, pp. 204-205.

¹⁴⁵ Fred Hoyle, *Nicolaus Copernicus: An Essay on His Life and Work*, New York: Harper and Row, 1973, p. 87.

might have produced the book that would have pleased the pope and not have been tried for heresy!”¹⁴⁶

Being completely honest with her reader, she adds:

Why, then, does Ptolemy come off so badly in this contest? Paradoxically, the enormous success of Ptolemaic astronomy is not an argument in its favor. It can account for all apparent movement in the heavens. It could also account for a great deal that never happens. It allows for too much. Copernican astronomy, as it has evolved, allows for far less. It's easier to think of something that Copernican theory could not explain. The more scientific way of putting this is that Copernican theory is more easily “falsifiable” than Ptolemy's, easier to disprove. Falsifiability is considered a strength...if new discoveries don't undermine it but fall neatly into place...

There is another criterion by which theories are judged, and, for better or worse, it shows that modern scientists do have a certain kinship with those recalcitrant seventeenth-century scholars they so disdain. When new theories and the implications of new discoveries disagree with the way a scientist personally feels the universe ought to run, he or she is reluctant to accept them.¹⁴⁷

¹⁴⁶ Kitty Ferguson, *Measuring the Universe* New York: Walker and Company, 1999, p. 106.

¹⁴⁷ Kitty Ferguson, *Measuring the Universe*, New York: Walker and Company, 1999, p. 107.

Is There a Copernican Conspiracy?

As there are many honest scientists and biblical exegetes who might reveal these facts to the public, there are just as many uneducated ones who are oblivious to them, or knowledgeable but dishonest ones who hide them. Still others are afraid to reveal them and hope that few people will seek to become educated and make provocative inquiries, for then the proverbial cat will be out of the bag. [Alexander von Humboldt](#) (d.1859), the founder of modern geography and of whom Charles Darwin said that he was “the greatest scientific traveler who ever lived,” and, of whom, after his death, Geoffrey Martin said “no individual scholar could hope any longer to master the world’s knowledge about the Earth,”¹⁴⁸ acknowledged the viability of geocentrism, but also the fear of revealing it:

I have known, too, for a long time, that we have no arguments for the Copernican system, but I shall never dare to be the first to attack it. Don’t rush into the wasp’s nest. You will but bring upon yourself the scorn of the thoughtless multitude. If once a famous astronomer arises against the present conception, I will communicate, too, my observations; but to come forth as the first against opinions which the world has become fond of – I don’t feel the courage.”¹⁴⁹

Not only can it be demonstrated mechanically, mathematically and scientifically that the sun and stars can revolve around the Earth, but using already-performed scientific experiments it can also be demonstrated that the Earth is in the center of the universe and motionless in space. In fact, the evidence is so plain that, in order to hide this information from the public, there is, as you will see before your eyes, a drama of cover-up and obfuscation that perhaps not even Hollywood could have dreamt up. Beneath it all is an intellectual war occurring between two opposing scientific philosophies that have been waging their respective campaigns for well nigh 500 years since its revival by Copernicus. Yet so successful have the heliocentrists been in their propaganda machine that the average person is completely unaware

¹⁴⁸ Geoffrey J. Martin and Preston E. James, *All Possible Worlds: A History of Geographical Ideas*, p. 131. If there was anyone who knew his trade, it was Humboldt. In addition to the thirty volumes he wrote about his geographical field studies, in 1845, at the age of 76, he wrote the book *Kosmos*, which is said to contain everything he knew about the Earth. The first volume, a general overview of the universe, sold out in two months and was promptly translated into many languages. Humboldt died in 1859 and the fifth and final volume was published in 1862, based on his notes for the work.

¹⁴⁹ Quoted in F. K. Schultze’s synopsis and translation of F. E. Pacshe’s *Christliche Weltanschauung* (cited in *De Labore Solis*, p. 133). Also cited in C. Schoepffer’s *The Earth Stands Fast*, C. H. Ludwig, 1900, p. 59.

there still might be a controversy. The main reason for the ignorance is that anyone who dares to question the *status quo* of current cosmology has been successfully ridiculed and silenced, many being threatened with the fate like that of Ignaz Semmelweiss.¹⁵⁰ As in any high-stakes game, there will be lying, cheating, theft, murder, twisting of evidence, political intrigue, religious skirmishes, opposing philosophies, and fortunes and fame, which are all involved in the ongoing war between the sun-centered and Earth-centered systems. The stakes are indeed high; in fact, as we shall see, they are about as high as any stakes that history has to offer.

Various battles between the heliocentrists and the geocentrists continued many years after the Catholic Church's confrontation with Galileo. As noted earlier, [Tycho Brahe](#) and [Johannes Kepler](#) sparked another skirmish, and this one, so say current historians, ended in the murder of Brahe at the hands of Kepler.¹⁵¹ As we touched upon earlier, the next climactic point came when the interferometer was invented – a device that could measure minute differences in the speed of light. The prevailing thought was, if the Earth is moving around the sun at 30 km/sec, this should have some effect on the speed of light discharged in the direction of that motion. A whole host of experimenters in the 1800s (e.g., Arago, Airy, Hoek, Fizeau, Fresnel, Michelson, Morley, Roentgen, Lodge, Rayleigh, Brace, et al.) confirmed to their satisfaction that the Earth was having no effect on the speed of light. In fact, it can be safely said that no experiment has ever been performed with such agonizing persistence and meticulous precision, and in every conceivable way, as that of determining whether the Earth is indeed moving through space. The haunting fact is: all of them have failed to detect any motion. By the time of physicist [Henrick Lorentz](#) in the early 1890s, it was obvious to many what the experimental results were saying. In Lorentz's own words: "Briefly, everything occurs as if the Earth were at rest..."¹⁵²

¹⁵⁰ Dr. Ignaz Semmelweiss (d. 1865) suggested to his medical colleagues that the reason women were dying after they gave birth is that the doctors who delivered their babies were carrying germs from the cadavers they had been dissecting previously. Semmelweiss suggested that these medical students wash their hands before attempting to assist in childbirth. Prior to Semmelweiss's solution, one woman in six died during childbirth. Unfortunately, Semmelweiss was ridiculed so severely by his medical colleagues that he suffered a mental breakdown and was committed to an insane asylum.

¹⁵¹ Joshua Gilder and Anne-Lee Gilder, *Heavenly Intrigue: Johannes Kepler, Tycho Brahe, and the Murder Behind One of History's Greatest Scientific Discoveries*, New York: Doubleday, 2004.

¹⁵² From Lorentz's 1886 paper, "On the Influence of the Earth's Motion on Luminiferous Phenomena," as quoted in Arthur Miller's *Albert Einstein's Special Theory of Relativity*, p. 20.

Lorentz knew the profound implications of his statement. He was very familiar with the dizzying world created by Einstein's Relativity, which was desperately commandeered to answer the failure of the interferometers to detect any motion of the Earth. In a personal letter he wrote to Einstein in 1915, it is apparent that he was feeling the effects of the drift into which Einstein forced the human race. In a moment of seeming desperation Lorentz wishes for a divine being that could hold it all together and make it work. He writes to Einstein:

A "world spirit," who would permeate the whole system under consideration without being tied to a particular place or "in whom" the system would consist, and for whom it would be possible to "feel" all events directly would obviously immediately single out one of the frames of reference over all others.¹⁵³

This is an amazing admission from Lorentz. Despite popular opinion, he was the impetus for Relativity, since it was his "transformation" equation that was the brains behind Einstein's Special Relativity.¹⁵⁴ In any case, it is obvious from the above quote that Lorentz could not live in the universe he created for himself. Consequently, he searched for a ubiquitous entity that could not only sense and coordinate all events instantaneously, but one that could also provide him with an absolute frame of reference. Why? Because Lorentz knew deep within his soul that it can work no other way. Things are an absolute mess without an absolute frame of reference from which everything else can be set and measured. As Einstein himself said:

It has, of course, been known since the days of the ancient Greeks that in order to describe the movement of a body, a second body is needed to which the movement of the first is referred."¹⁵⁵

¹⁵³ Henrick Lorentz to Albert Einstein, January 1915, Robert Schulmann, A. J. Kox, Michael Janssen and József Illy, editors, *The Collected Papers of Albert Einstein, Correspondence 1914-1918*. Princeton: Princeton University Press, 1998, Document 43.

¹⁵⁴ The basic formula undergirding all of Lorentzian and Einsteinian Relativity is $L = L\sqrt{1 - v^2/c^2}$, where L = length, v = velocity and c = the speed of light. Yet even though Einstein borrowed Lorentz's formula, Lorentz acknowledged: "the theory of relativity is really solely Einstein's work" (*Astrophysical Journal*, 68, 350, 1928). Historian Edmund Whittaker, however, believes that Lorentz and Poincaré were the creators of Relativity (*A History of the Theories of Ether and Electricity*, vol. 1-2, New York, Harper and Brothers, 1953, pp. 27-77).

¹⁵⁵ Article written by Einstein at the request of the *London Times*, November 28, 1919, as cited in Einstein's *Ideas and Opinions*, Wings Books, Crown Publishers, 1954, p. 229.

But alas, once the Copernican system came into vogue, no longer was there a comforting reference point. Consequently, [Isaac Newton](#) soon discovered that: “It may well be that there is no body really at rest to which the places and motions of others may be referred.”¹⁵⁶ Even with his alternative concept of “absolute space,” Newton found no solace. He writes:

It is indeed a matter of great difficulty to discover and effectually to distinguish the true motions of particular bodies from the apparent, because the parts of that immovable space in which these motions are performed do by no means come under the observations of our senses.¹⁵⁷

Likewise, [Arthur Eddington](#) laments:

...for there is nothing to guide him as to the planet to be selected for the standard of rest....There is no answer, and so far as we can see no possibility of an answer....Our common knowledge of where things are is not a miraculous revelation of unquestionable authority....Location is not something supernaturally revealed to the mind....It would explain for instance, why all the forces of Nature seem to have entered into a conspiracy to prevent our discovering the definite location of any object...naturally they cannot reveal it, if it does not exist....Nature has been too subtle...she has not left anything to betray the frame which she used....Our predecessors were wise in referring all distances to a single frame of space...”¹⁵⁸

We write our treatise offering to Eddington and the rest of the world that, indeed, there is “a guide as to the planet to be selected as the standard or rest”; that Nature has not “betrayed” or formed a

¹⁵⁶ Isaac Newton, *Philosophiae Naturalis Principia Mathematica*, Bk. 1 (1689); translated by Andrew Motte (1729), revised by Florian Cajori, Berkeley: University of California Press, 1934, Definition VII, p. 8. Newton continues in Definition VIII with: “And therefore as it is possible, that in the remote regions of the fixed stars, or perhaps far beyond them, there may be some body absolutely at rest; but impossible to know from the position of bodies to one another in our regions, whether any of these do keep the same position to that remote body; it follows that absolute rest cannot be determined from the position of bodies in our regions” All of Newton’s hand-wringing is, of course, superfluous if the Earth is fixed in space.

¹⁵⁷ Isaac Newton, *Philosophiae Naturalis Principia Mathematica*, Bk. 1 (1689); translated by Andrew Motte (1729), revised by Florian Cajori, Berkeley: University of California Press, 1934, Definition XIV, p. 12.

¹⁵⁸ Arthur Eddington, *The Nature of the Physical World*, New York, MacMillian Company and Cambridge University Press, 1929, pp. 15, 17, 18, 27, 25, in order of ellipses.

“conspiracy” against us; rather her knowledge comes from a “miraculous revelation of unquestionable authority” – God through Holy Writ. [Pope Pius X](#) once wrote:

Human science gains greatly from revelation, for the latter opens out new horizons and makes known sooner other truths of the natural order, and because it opens the true road to investigation and keeps it safe from errors of application and of method. Thus does the lighthouse show many things they otherwise would not see, while it points out the rocks on which the vessel would suffer shipwreck.¹⁵⁹

As even [Andreas Osiander](#) admitted in the Foreword he wrote for the book that started it all, Copernicus’ *De revolutionibus*:

But since for one and the same movement varying hypotheses are proposed from time to time...the astronomer much prefers to take the one which is easiest to grasp. Maybe the philosopher demands probability instead; but neither of them will grasp anything certain or hand it on, unless it has been divinely revealed to him....And as far as hypotheses go, let no one expect anything in the way of certainty from astronomy, since astronomy can offer us nothing certain, lest, if anyone take as true that which has been constructed for another use, he go away from this discipline a bigger fool than when he came to it.¹⁶⁰

If science chooses against this path, indeed, life will seem like a “conspiracy” against mankind, for he will be forever mired in the haunted house of moving targets and elusive shadows. Without a standard of rest, simply put, man will never find rest. As [George Berkeley](#) once registered against Newton as he recognized the full implications of the Copernican theory, if we start off with relative observations but end up with an absolute reference frame, then somewhere along the way we must have been duly influenced by philosophical preferences. Accordingly he observes:

If every place is relative, then every motion is relative and as motion cannot be understood without a determination of its direction which in its turn cannot be understood except in relation to our or some other body. Up, down, right, left, all directions and places are based on some relation and it is necessary to suppose another body distant from the moving one.¹⁶¹

¹⁵⁹ Pope Pius X, encyclical of March 12, 1904, *Iucunda Sane*, 35.

¹⁶⁰ *On the Revolution of the Heavenly Spheres*, translated by Charles Glenn Wallis, New York, Prometheus Books, 1995, p. 4.

Following the Greek astronomer Heraclides, Berkeley was one of the first moderns to suggest that it would be possible to construct a system in which the universe rotates around a fixed Earth, and one which will produce the same mechanical effects as when the Earth rotates in a fixed universe. He writes:

But suppose the heaven of fixed stars were suddenly created and we shall be in a position to imagine the motion of the globes by their relative position to the different parts of the heaven.”¹⁶²

Over a hundred years later, Ernst Mach put the idea and its mathematics on paper. But without a sure footing as to which system was actually correct, Mach’s observation led inevitably to the theory of Relativity.

Alas, late 19th century man came ever so close to discovering, scientifically, the correct system, but faced with such an unexpected and overwhelming truth, he, as the common saying goes, blinked first, and things have never been the same since. Einstein was well aware of the anti-Copernican implications of the interferometer experiments. In the words of one of his biographers:

The problem which now faced science was considerable. For there seemed to be only three alternatives. The first was that the Earth was standing still, which meant scuttling the whole Copernican theory and was unthinkable.¹⁶³

Everyone in the physics establishment saw the same implications, and they were beside themselves with consternation. As several authors describe it:

The data [of the interferometers] were almost unbelievable...There was only one other possible conclusion to draw – that the Earth was at rest. This, of course, was preposterous.¹⁶⁴

¹⁶¹ *De Motu* (“On Motion”), 1721, as cited in William G. V. Rosser’s *The Theory of General Relativity*, pp. 453-454 who cites Dennis Sciama’s *The Unity of the Universe*, Anchor Books, New York, 1959, p. 97.

¹⁶² Dennis Sciama, *The Unity of the Universe*, Anchor Books, New York, 1959, p. 98.

¹⁶³ *Einstein: The Life and Times*, Avon Book, New York, NY, 1984, p. 109-110.

¹⁶⁴ Bernard Jaffe, *Michelson and the Speed of Light*, Garden City, NY, Doubleday and Company, 1960, p. 76.

Always the speed of light was precisely the same...Thus, failure [of Michelson-Morley] to observe different speeds of light at different times of the year suggested that the Earth must be 'at rest'...It was therefore the 'preferred' frame for measuring absolute motion in space. Yet we have known since Galileo that the Earth is not the center of the universe. Why should it be at rest in space?¹⁶⁵

In the effort to explain the Michelson-Morley experiment...the thought was advanced that the Earth might be stationary....Such an idea was not considered seriously, since it would mean in effect that our Earth occupied the omnipotent position in the universe, with all the other heavenly bodies paying homage by revolving around it.¹⁶⁶

Even [Albert Michelson](#) couldn't avoid the implications of his own experiment:

This conclusion directly contradicts the explanation of the phenomenon of aberration which has been hitherto generally accepted, and which presupposes that the Earth moves..."¹⁶⁷

But....

As Einstein wrestled with the cosmological implications of the General Theory, the first of these alternatives, the Earth-centered universe of the Middle Ages, was effectively ruled out...¹⁶⁸

Indeed it was "ruled out," yet not by any scientific proof but only because, after having five hundred years of Copernicanism drummed into one's head from childhood, it was "unthinkable" to believe that mankind got it wrong and that the Earth was actually motionless in space. But there was a price to pay for this presumption. Rejecting what was "unthinkable" created what was unmanageable. Since, on the one hand, an Earth-centered cosmos was "ruled out," but, on the other hand, Einstein was forced to answer both the results of the interferometer experiments and Maxwell's electromagnetic equations, his only

¹⁶⁵ Adolf Baker, *Modern Physics and Antiphysics*, Reading, MA, Addison-Wesley Publishing Company, 1970, pp. 53-54.

¹⁶⁶ Arthur S. Otis, *Light Velocity and Relativity*, Yonkers-on-Hudson, NY, Christian E. Burckel and Associates, 1963, p. 58.

¹⁶⁷ Albert A. Michelson, "The Relative Motion of the Earth and the Luminiferous Ether," *American Journal of Science*, Vol. 22, August 1881, p. 125.

¹⁶⁸ *Einstein: The Life and Times*, p. 267.

“alternative” was to invent a whole new physics; in fact, it was necessary to adopt a whole new way of looking at the world. If the Earth wouldn’t budge, then science had to budge. Consequently, Relativity theory advanced principles and postulates that heretofore would have been considered completely absurd by previous scientists, things such as matter shrinking, clocks slowing down, and mass growing larger; that two people could age at different rates, that space was curved, that light travels at the same speed for all observers (even observers moving at the speed of light); that time and space are one entity, and many other strange and bizarre concepts, all in an effort to answer the numerous experiments that showed the Earth was motionless in space. In that day *The Times* of London called Einstein’s Relativity “an affront to common sense.”¹⁶⁹ Indeed it was, and still is.

In the face of Relativity’s fantastic postulates and the utter upheaval it caused in science and culture, one would expect that the burden of proof would be completely on Einstein and his fellow Relativists to show that his theory was the only viable explanation of reality, not merely an *ad hoc* alternative that was created under the pressure of unexplainable experiments. But the historical record shows that this was never done. By 1920, Relativity was accepted with impunity,¹⁷⁰ for up to that time, and still today, it is the only way to escape the “unthinkable” alternative – a motionless Earth in the center of the universe. But what the public at large is kept from knowing is that, if Relativity fails, there is no other answer for modern man. Men will be forced to accept an Earth-centered cosmos, for that is what all the interferometer experiments dictate. As even his biographer suggests, we will discover that Einstein’s Relativity was invented for the express purpose of freeing the world from having to adopt the “unthinkable” immobile Earth – the very one Tycho Brahe had bequeathed to Kepler and which the latter refused to accept for his own devious purposes. In fact, Einstein would be called “a new Copernicus.”¹⁷¹

As this book progresses, because there is such an intimate link between the heliocentric/geocentric battle and the cosmology of [Albert Einstein](#), much of the time will be spent unraveling and critiquing the theories of Relativity. We will seek to break down the façade upon which Relativity is built. Although Relativity proponents will claim that,

¹⁶⁹ *Einstein: The Life and Times*, p. 101. In 1920, physicist Oliver Lodge said that Relativity was “repugnant to common sense” and of Relativists he said “however much we may admire their skill and ability, I ask whether they ought not to be regarded as Bolsheviks and pulled up” (“Popularity Relativity and the Velocity of Light,” *Nature*, vol. CVI, November 4, 1920, p. 326).

¹⁷⁰ We will address the supposed “proof” of General Relativity from the 1919 eclipse photographs in Appendix 4: “Do the 1919 Eclipse Photographs Prove General Relativity?” later in this volume.

¹⁷¹ *Einstein: The Life and Times*, p. 192.

since Einstein's mathematics can be made to work, even then, the question that haunts Relativity is whether Einstein's math is merely a case of saying that $3 + 1 = 4$ when in reality the correct equation is $2 + 2 = 4$. In other words, does Einstein's math represent what is occurring in physical reality, or does the math merely save the appearances? As the scientific philosopher, [Karl Popper](#) observes:

Properly understood, a mathematical hypothesis does not claim that anything exists in nature which corresponds to it...It erects, as it were, a fictitious mathematical world behind that of appearance, but without the claim that this world exists. [It is] to be regarded only as a mathematical hypothesis, and not as anything really existing in nature.¹⁷²

Certainly, if the Earth is fixed, then space and time are fixed, and consequently Einstein's model is fallacious, even though the math can be made to look as if it is correct. As physicist Herbert Dingle pointed out about mathematics:

...in the language of mathematics we can tell lies as well as truths, and within the scope of mathematics itself there is no possible way of telling one from the other. We can distinguish them only by experience or by reasoning outside the mathematics, applied to the possible relation between the mathematical solution and its supposed physical correlate.¹⁷³

As we will see in the following pages, however, although mathematics is touted as the hand-maiden of modern Copernican cosmology, in reality it has become its worst enemy. In every case, the mathematics reveals insurmountable flaws in whatever cosmological model is being proposed. Whether it's the Big Bang theory, the Steady State theory, the closed universe, the open universe, the Friedman-Robertson-Walker model or the dozens of other possibilities available from plugging in different numbers to Einstein's field equations, the math always reveals incongruities. None of them can claim supremacy. As Omer noted in 1948:

E. Hubble has shown that the observational data which he has obtained do not agree satisfactorily with the homogeneous relativistic cosmological models [Big Bang models]...the

¹⁷² Karl Popper, *Conjectures and Refutations*, p. 169, commenting on the concepts of George Berkeley, *Siris*, 1744, p. 234, and *De Motu*, pp. 18, 39. Popper adds: "But it can easily be misinterpreted as claiming more, as claiming to describe a real world behind the world of appearance. But no such world *could* be described; for the description would necessarily be meaningless" (*ibid.*).

¹⁷³ *Science at the Crossroads*, p. 33.

homogeneous models give an unrealistic picture of the physical universe. Perhaps this should not be too surprising, since Tolman [*Proceedings of the National Academy of Sciences*, 20, 169, 1934] has shown that, subject to certain simplifying conditions, a homogeneous model is unstable under perturbations in density. Any local tendency to expand would be emphasized by further expansion. Likewise, any local tendency to contract would be followed by further contraction. Thus if a homogeneous model is disturbed, it becomes nonhomogeneous.¹⁷⁴

¹⁷⁴ Guy C. Omer, Jr., "A Nonhomogeneous Cosmological Model," *Journal of the American Astronomical Society*, vol. 109, 1949, pp. 165-166. See also W. B. Bonnor, "The Instability of the Einstein Universe,"

The Demise of Modern Cosmology

Beyond the math, most physicists have begun to see the flaws in Einstein's theories on merely a practical level. They have been quietly burying his theories for the past few decades, but are somewhat reluctant to invite the public to the funeral for fear of demoralizing them, so it has been decided to let them die a slow but inevitable death by themselves. It was no less a scientific luminary than [Stephen Hawking](#) who revealed the awful truth:

We already know that general relativity must be altered. By predicting points of infinite density – singularities – classical general relativity predicts its own downfall....When a theory predicts singularities such as infinite density and curvature, it is a sign that the theory must somehow be modified.¹⁷⁵

Einstein knew this as well. He struggled his whole life to produce singularity-free equations, but was never successful. Hawking continues:

If general relativity is wrong, why have all experiments thus far supported it? The reason that we haven't yet noticed any discrepancy with observation is that all the gravitational fields that we normally experience are very weak.¹⁷⁶

In reality, it is not only strong gravitational fields that demonstrate the erroneous tenets of General Relativity but, as we will see in the appendices of our treatise, even what Hawking understands as the so-called “experiments thus far supporting it,” in reality, do not support Relativity theory at all. When examined very closely, they actually disprove it. We speak here mainly of Einstein's explanation for the perihelion of Mercury and the bending of starlight near the sun.¹⁷⁷

Hence, it is not just singularities and blackholes that are the problem with Relativity. The whole theory has become suspect of being flawed. A *Discover* magazine issue commemorating the 100th anniversary of Einstein's 1905 Relativity theory put it even more candidly:

Albert Einstein got it wrong. Not once, not twice, but countless times. He made subtle blunders, he made outright goofs, his

¹⁷⁵ *A Briefer History of Time*, New York, Bantam Dell, 2005, pp. 102, 84; *Black Holes and Baby Universes*, New York, Bantam Books, 1994, p. 92.

¹⁷⁶ *A Briefer History of Time*, New York, Bantam Dell, 2005, pp. 102.

¹⁷⁷ See Appendix 4: “Do the 1919 Eclipse Photographs Prove General Relativity?”; Appendix 5: “Does Mercury's Residual Perihelion Prove General Relativity?”; and Appendix 6: “Does the Hefe-Keating Experiment Prove General Relativity?”

oversights were glaring. Error infiltrated every aspect of his thinking. He was wrong about the universe, wrong about its contents, wrong about the inner workings of atoms...In 1911 Einstein predicted [by Relativity] how much the sun's gravity would deflect nearby starlight and got it wrong by half. He rigged the equations of general relativity to explain why the cosmos was standing still when it wasn't. Beginning in the mid-1920s, he churned out faulty unified field theories at a prodigious rate. American physicist Wolfgang Pauli complained that Einstein's 'tenacious energy guarantees us on the average one theory per annum,' each of which 'is usually considered by its author to be the "definitive solution."' ¹⁷⁸

As the popular and technical magazine *Scientific American* gently put it:

Einstein has become such an icon that it sounds sacrilegious to suggest he was wrong...But if most laypeople are scandalized by claims that Einstein may have been wrong, most theoretical physicists would be much more startled if he had been right. ¹⁷⁹

In 1920, just after the famous eclipse photographs produced by Sir Arthur Eddington in 1919 (which purportedly showed at least one photograph of starlight bending near the sun at the angle Einstein predicted), Einstein's "curved space" became the major plank of modern cosmology. Overnight all of modern science was turned upside down. Einstein went so far as to claim that nothing in the universe can be absolutely straight. He asserted that a disc whirling at high speed would be shorter around its rim and thus upset the value of π and all the rest of Euclidean geometry. The impact of his theory was overwhelming. But in the mid-1920s, [Willem de Sitter](#), who made a thorough use of Einstein's equations, demonstrated that his "curved" universe could not be proven. De Sitter consulted with Einstein and showed him the mathematical proofs. By 1932, Einstein and de Sitter co-wrote an article, which included the statement: "We must conclude that at the present time it is

¹⁷⁸ Karen Wright, *Discover* contributing editor, "The Master's Mistakes," September 2004, p. 50. Wright was apparently chosen to diffuse the Einstein mystique, since the other articles in the issue are mostly positive. She concludes: "Yet Einstein's mistakes could be compelling and instructive, and some were even essential to the progress of modern physics." Another writer from the same magazine, Robert Kunzig, states: "It's just a matter of time, most physicists think, before Einstein fails. Relativity touches so much of physics that a violation could show up almost anywhere" (*ibid.*, p. 60).

¹⁷⁹ *Scientific American*, "Was Einstein Right?" by George Musser, September 2004, p. 88. Continuing, he writes: "...when the general theory of relativity...meets quantum mechanics...it is relativity that must give way. Einstein's masterpiece, though not strictly 'wrong,' will ultimately be exposed as mere approximation."

possible to represent the facts without assuming a curvature of three dimensional space.”¹⁸⁰ The *Science News Letter* of April 2, 1932 stated:

Einstein and De Sitter Return to Euclidean Idea of Cosmos:
Prof. Albert Einstein, father of relativity, says that space may be and probably is the sort of uncurved, three-dimensional space that Euclid imagined and countless generations of schoolboys have learned...Prof. Willem de Sitter, Dutch astronomer, who had built his own shape of universe on Einsteinian foundations, joins with Prof. Einstein in espousing space which is on the average Euclidean....This joint announcement...is sure to cause a furor in the world of science....In the Euclidean universe now re-enthroned, light travels in straight lines and goes on and on forever and ever.

Four years later, the famous astronomer [Edwin Hubble](#) wrote: “if redshifts are not primarily due to velocity shifts...there is no evidence of expansion, no trace of curvature, no restriction of the time scale.”¹⁸¹ Hubble’s complaint is related to the issue we hear about so often today concerning “Dark Matter.” The main reason the majority of modern scientists are still clinging so closely to the existence of Dark Matter – to the tune of having it comprise a whopping 95% of the known universe, even though no one has ever seen a trace of it – is that without it Einstein’s field equations simply will not work. If Einstein’s field equations are invalid, then so is the Big Bang to which they gave birth. As one author put it:

Dark matter is needed if one assumes Einstein’s field equations to be valid. However, there is no single observational hint at particles which could make up this dark matter. As a consequence, there are attempts to describe the same effects by a modification of the gravitational field equations, e.g. of Yukawa form, or by a modification of the dynamics of particles, like the MOND ansatz, recently formulated in a relativistic frame. Due to the lack of direct detection of Dark Matter particles, all those attempts are on the same footing.¹⁸²

After Hubble, three years later, in 1939, Herbert Ives demonstrated that the bending of starlight near the sun is a result of the *slowing down* of light in gravitational fields, not because of a warping of space-time. As a beam of light passes the sun, the part of the beam that is

¹⁸⁰ *Proceedings of the National Academy of Sciences*, Washington, 18, 1932, pp. 213-214.

¹⁸¹ *Astrophysical Journal* 84, 517, 1936, p. 553.

¹⁸² C. Lämmerzahl, O. Preuss and H. Dittus, “Is the Physics within the Solar System Really Understood,” ZARM, University of Bremen, Germany; Max Planck Institute for Solar System Research, Germany, April 12, 2006, p. 2.

nearer to the sun will be slowed more than the part of the beam further away. (Analogously, hair curls because one side of the shaft grows slower than the other). The sun acts the same as a lens, since lenses slow the speed of light, which we see as refraction.¹⁸³

The problems continue for Relativity. Physicists who have put their whole careers behind Einstein's theory admit that it cannot be reconciled with the burgeoning field of Quantum Mechanics, which has been so successful at predicting the inner workings of nature. In fact, not only is there no reconciliation for the two theories, they actually obliterate one another. Popular science writer and physicist [Brian Greene](#) adds:

Bell's reasoning and Aspect's experiments show that the kind of universe Einstein envisioned may exist in the mind, but not in reality...we now see that the data rule out this kind of thinking; the data rule out this kind of universe.¹⁸⁴

After spending over one thousand pages convincing their readers of the glories of General Relativity, Charles Misner, Kip Thorne and John Wheeler (some of the more authoritative names in modern physics), finally admit that:

The uncertainty principle [of Quantum Mechanics] thus deprives one of any way whatsoever to predict, or even to give meaning to, "the deterministic classical history of space evolving in time." No prediction of spacetime, therefore no meaning for spacetime, is the verdict of the quantum principle. That object which is central to all of classical general relativity, the four-dimensional spacetime geometry, simply does not exist, except in a classical approximation.¹⁸⁵

¹⁸³ *Journal of the Optical Society of America*, 29:183-187, 1939.

¹⁸⁴ Brian Greene, *The Fabric of the Cosmos: Space, Time and the Texture of Reality*, New York, Alfred A. Knopf, 2004, pp. 120-121. For more information on the nature of Bell's Theorem and Aspect's experiments, see Chapter 7. NB: Although we quote Greene, we are not hereby adopting his advocacy for String Theory.

¹⁸⁵ *Gravitation*, New York, W. H. Freeman and Company, 1973, 25th printing, pp. 1182-1183. That two diametrically opposed theories (General Relativity and Quantum Mechanics) can both hold center stage in physics today, reveals like nothing else the shaky foundation upon which modern cosmology is built. On the one hand, Misner, et al., state that "the standard Big-Bang model of the universe [is] predicted by General Relativity," but admit that "General Relativity is incapable of projecting backward through the singularity to say what 'preceded'" the Big Bang, "and, unfortunately, no problem is farther from solution," since General Relativity totally breaks down at that point (*ibid.*, p. 770).

Long before these current scientists finally discovered the flaws in Einstein's system, his critics in earlier times were quite numerous. Herbert Dingle, at first one of the scientists chosen to write popular editions of the General Theory of Relativity in the 1920s, and whose supportive essay was included in Schlipp's 1949 compendium *Albert Einstein: Philosopher-Scientist*, eventually found serious anomalies in Relativity.¹⁸⁶ By the 1960s he became Einstein's most formidable critic. Siding with Einstein, *Nature*, the most prestigious science journal known then and today, simply refused to publish Dingle's critique, resorting instead to accusing him of "dishonesty" for his work. In Dingle's own words:

"...one of the chief stumbling-blocks to the general reader, as I know from my wide correspondence, is the difficulty of believing that, if the theory [of Einstein] is so plainly wrong, it could have been believed by everyone for more than 50 years. The book [of Dingle's] explains the very peculiar historical circumstances that have brought this about. I think I can say without conceit that there is no one now living who has had so much experience as I of the whole course of development and had personal contact with practically all the pioneers of the subject, and so is able to give a credible explanation of the

¹⁸⁶ In Dingle's own words: "To the best of my knowledge there is no one now living who can give objective evidence that he is more competent in the subject than I am...I have been studying relativity for more than 50 years. I learnt it in the first place from the late professor A[lfred] N[orth] Whitehead, who encouraged me to write my first book on the subject (*Relativity for All* – Methuen). During the following half-century I have studied intensively the field of investigation to which it belongs, and discussed the theory with practically all those physicists whose names are best known in connection with it – Einstein, Eddington, Tolman, Whittaker, Schrödinger, Born, Bridgman, to name a few: I knew some of them intimately. I worked for a year (1932-3) with Tolman while he was writing his now standard work, *Relativity Thermodynamics and Cosmology* (Clarendon Press)...When in 1940, I published my second book on the subject (*The Special Theory of Relativity* – Methuen)...Max Born wrote me: 'I have enjoyed it very much, as your explanations of the difficult subject are very clear and well presented.'...Whittaker...published his history of the whole field of thought of which special relativity forms a part...I sent him some comments...to which he replied: 'Many thanks for the corrections and comments. You have detected several mistakes...and some of the remarks and suggestions you make could have originated only from a vast background of knowledge, which fills me with admiration.' When the volume on Einstein in *The Library of Living Philosophers* (published in 1949) was prepared, there were only two Englishmen among the twenty-five contributors selected from the world; I was one....When Einstein died I was summoned to broadcast a tribute to him on BBC television, which I did. Later, Granada television invited me to give a course on relativity, but by that time I was fairly well convinced that the special theory was untenable, so I refused. There are two articles on the subject in the *Encyclopedia Britannica*, one by an American and the other by me. It was written before I had reason to reject the special theory...I could continue in this vein, but it is distasteful and, moreover, I consider that the question should be decided on its intrinsic merits and not by a comparison of personal records" (Herbert Dingle, *Science at the Crossroads*, pp. 106-107).

apparently incredible. That, notwithstanding its incredibility, the simple error in the theory is indeed a fact is shown by the unbreakable silence of all the leading authorities (except McCrea and Lyttleton) on my criticism, and the failure of NATURE to keep its promise to comment (which could only be a climbdown)...¹⁸⁷

“The absurdity which Mr. Stadlen re-affirms illustrates ‘the present state of the scientific world’: scientists have lost the power to believe that special relativity may be wrong...they resort to any absurdity to escape the inescapable. The change in ‘the state of the scientific world’ is that whereas, according to accepted tradition, in these circumstances the theory would at once be rejected, I have not found one of the ‘authorities’ with the courage either to make this choice or to admit his change of criterion for truth; the book records ample instances of my efforts and their futility. To take but one of its examples, a universally acknowledged authority on the theory, after a long correspondence, asked me if I was hoaxing, for ‘I cannot bring myself to believe that you are as stupid as you make yourself out to be’ – my stupidity lying in the fact that I subjected special relativity to criticism. Not only could one of the acutest minds in the business not see through the “hoax,” he could not even decide it is was a hoax, so he gave me up. That is the universal state of affairs, and it was to inform the unsuspecting public – and with a faint hope that the exposure might stab the “establishment” broad awake before anything disastrous happens...¹⁸⁸

“I am not so much interested in the scientific reviews – after all, there is nothing they can do but evade the point and misrepresent the book, as NATURE and NEW SCIENTIST have done...¹⁸⁹

“A recent issue of NATURE contains a review [241, 143 (1973)], by Professor John Ziman, of my book, Science at the Crossroads...But Professor Ziman calls the book ‘sincere, dishonest’. I do not understand how it can be both, but to the charge of dishonesty I cannot be indifferent. Not only does it defame my moral character, but also, since I have stated plainly

¹⁸⁷ Personal letter signed by Herbert Dingle written to Timothy O’Keeffe of Martin, Brian and O’Keeffe, Ltd, London, England, on March 20, 1972. Copy on file.

¹⁸⁸ Personal letter signed by Dingle to Timothy O’Keeffe dated October 14, 1972, emphasis, including capitals and underlining, in the original. “Mr. Stadlen” was hired by *The Listener* to review Dingle’s book, *Science at the Crossroads*, eventually published by O’Keeffe. Copy on file.

¹⁸⁹ Personal letter signed by Dingle to Timothy O’Keeffe, dated October 26, 1972. Copy on file. Emphasis, including capitals and underlining, in the original

that ‘The primary and inescapable purpose of this book is to make known, to those with an infeasible right to the knowledge, the present state of the scientific world as revealed by its practice, and to bring it into comparison with what is generally believed, and implicitly trusted, to be its state’...a conviction of dishonesty would entitle – indeed, compel – both actual and intending serious readers to dismiss my whole account as culpably untrustworthy. I must therefore ask Professor Ziman either to substantiate his charge or publicly, unambiguously and unreservedly to withdraw it.”¹⁹⁰

After some legal haggling, *Nature* eventually wrote an apology to Dingle that was published in its June 8, 1973, issue. *Science* also issued a similar apology on June 15, 1973.

Other well-known and accomplished physicists, many of them having received their own Nobel Prizes, rejected Einstein’s Relativity theories in the early going, and more came on board as time progressed. Respected scientists such as Appell, Aspden, Barter, Beckmann, Bergson, Bouasse, Bragg, Brown, Brillouin, Callahan, Cauchy, Champeney, Cullwic, Darboux, Denisov, Dingler, Dudley, Duport, Essen, Galeczki, Gehrcke, Graneau, Guillaume, Hatch, Heaviside, Henderson, Ives, Kantor, Kanarev, Kastler, Kraus, Lallemand, Larmour, LeCornu, Lenard, LeRoux, Levi-Civita, Lodge, Lorentz, Lovejoy, Lynch, Mach, MacMillan, Magie, McCausland, Michelson, Miller, Montague, Moon, Moulton, O’Rahilly, Painlevé, Phipps, Picard, Planck, Poincaré, Poor, Radakov, Ricci, Rutherford, Sagnac, Seeliger, Selleri, Soddy, Stark, Turner, Weyland, et al., discovered the same anomalies, and many of them wrote major critiques against Einstein between the 1920s and 1960s. Even Leopold Infeld, although authoring a book with Einstein in 1938 titled *The Evolution of Physics*, ten years later, when applying Einstein’s formulas to the structure of the universe, writes: “Einstein’s original ideas, as viewed from the perspective of our present day, are antiquated if not even wrong.”¹⁹¹

¹⁹⁰ Personal unsigned letter from Dingle “To the Editor of NATURE,” no date given. Copy on file. The only scientist of international repute to offer a critique of Dingle was Max Born. Born writes only the following words: “The simple fact that all relations between space co-ordinates and time expressed by the Lorentz transformations can be represented geometrically by Minkowski diagrams should suffice to show that there can be no logical contradiction in the theory.” Dingle replied but there was no follow up from Born. Born’s answer was hardly sufficient, since as Dr. Ian McCausland stated: “Since the Lorentz transformation is contained in the special theory, but is not the whole theory, it is illogical to claim that any property of the Lorentz transformation is a sufficient condition for the whole theory to be free of logical contradiction” (“The Twins Paradox of Relativity,” *Wireless World*, July 1981).

¹⁹¹ Leopold Infeld, “On the Structure of the Universe,” in *Albert Einstein: Philosopher-Scientist*, p. 477.

If these evidences fail to give pause, then perhaps a few statements from Einstein himself at the end of his career will help put things in proper perspective. Whether he meant it as an omen or an obituary, nevertheless, Einstein was apparently feeling the depression of over half a century of doubt about his theories when, on his seventieth birthday he remarked in a March 28, 1949 letter to his old friend Maurice Solovine:

You imagine that I regard my life's work with calm satisfaction. But a close look yields a completely different picture. I am not convinced of the certainty of a simple [single] concept, and I am uncertain as to whether I was both a heretic and reactionary who has, so to speak, survived himself.¹⁹²

These thoughts had been brewing in Einstein's mind for a few years. In a letter to J. Lee in 1945 he wrote:

A scientific person will never understand why he should believe opinions only because they are written in a certain book. Furthermore, he will never believe that the results of his own attempts are final.¹⁹³

In 1948 Einstein wrote the following words in the Foreword to a popular book on Relativity:

Moreover, the present state of our knowledge in physics is aptly characterized. The author shows how the growth of our factual knowledge, together with the striving for a unified theoretical conception comprising all empirical data, has led to the present situation which is characterized – notwithstanding all successes – by an uncertainty concerning the choice of the basic theoretical concepts.¹⁹⁴

Here we see in Einstein an introspection that he rarely revealed to his physics colleagues, many who were in intense competition with him.

¹⁹² *Letters to Solovine*, translated by Wade Baskin from the French *Lettres à Maurice Solovine*, New York: Philosophical Library, Inc., 1987, p. 111. Einstein's wording in the original German of the sentence "Da ist kein einzeiger Begriff..." more likely refers to "not a single concept," since *einzeiger* is closer to the meaning of "one" or "single," whereas *einfach* would be the more common word for "simple." In the same set of letters Einstein reveals his doubts about General Relativity.

¹⁹³ Alice Calaprice, editor, *The Expanded Quotable Einstein*, Princeton University Press, Princeton, NJ, 2000, p. 14.

¹⁹⁴ Lincoln Barnett, *The Universe and Dr. Einstein*, Mentor Books, The New American Library of World Literature, revised edition, 1950, p. 10.

But they are rather disheartening words from a man who turned the world upside down with his highfalutin theories. In locating his target of derision as “the basic theoretical concepts,” Einstein is casting doubt on the whole enterprise of modern physics, admitting that his and other theories may, in fact, be totally mistaken regarding how the universe operates.

Einstein’s intimate thoughts were revealed only to the best of his personal friends, the people who really knew the man behind the persona. To them Einstein’s negative assessment of his life’s work was not merely an exercise in self-deprecation. This is noted also by yet another revealing comment Einstein made to Michel Besso, his closest confidant, in a 1954 letter:

I consider it quite possible that physics cannot be based on the field concept, i.e., continuous structures. In that case, *nothing* remains of my entire castle in the air, gravitation theory included, [and of] the rest of modern physics.¹⁹⁵

Two months before his death, he admitted that he could not make the mathematics of his theory of gravitation work correctly. To Solovine he writes:

I have finally managed to introduce another noteworthy improvement into the theory of the gravitational field (theory of the nonsymmetrical field). But not even these simplified equations can be verified by the facts as yet because of mathematical difficulties. Warmest greetings to you and your wife. Your[s], A. Einstein.¹⁹⁶

After remarking about “...the odd arguments which Ptolemy advances against Aristarchus’ opinion that the world rotates and even moves around the sun,” Einstein ironically admits to Solovine in the same November 25, 1948, letter:

In my scientific activity, I am always hampered by the same mathematical difficulties, which make it impossible for me to confirm or refute my general relativist field theory.

¹⁹⁵ Abraham Pais, *Subtle is the Lord: The Science and the Life of Albert Einstein*, Oxford University Press, 1982, 2005, p. 467. Pais argues that Einstein’s self-assessment was “unreasonably harsh” (*ibid*), a downplaying that shows Pais knows how damaging the quote is to the reputation of Einstein. Still, Pais admits to other such sentiments from Einstein, such as the letter to Born in 1940: “Our respective hobby-horses have irretrievably run off in different directions....Even I cannot adhere to [mine] with absolute confidence” (*ibid*).

¹⁹⁶ *Letters to Solovine*, translated by Wade Baskin from the French *Lettres à Maurice Solovine*, New York: Philosophical Library, Inc., 1987, pp. 159, written on February 27, 1955, Einstein’s death coming on April 18, 1955.

As we noted previously, the mathematics Einstein employed to help bolster his Relativity theory is the same mathematics that shows geocentrism as a viable alternative to heliocentrism, therefore Einstein could never be sure which one was the correct model. Like many, he ignored the implications of his own theory and decided to “leave this question for the time being and accept Copernicus’ point of view.”¹⁹⁷

After Einstein, men began to look more deeply into the starry cosmos. Evidence that Earth was in the center of the universe was discovered by one of the world’s most famous astronomers, [Edwin Hubble](#), the man after whom the *Hubble Space Telescope* is named. So shocked was Hubble when he examined the peculiar light coming from the stars that the only thing he could offer to refute an Earth-centered cosmos was to say:

...Such a condition would imply that we occupy a unique position in the universe, analogous, in a sense, to the ancient conception of a central Earth...This hypothesis cannot be disproved, but it is unwelcome and would only be accepted as a last resort in order to save the phenomena. Therefore we disregard this possibility.... the unwelcome position of a favored location must be avoided at all costs.... such a favored position is intolerable...Therefore, in order to restore homogeneity, and to escape the horror of a unique position...must be compensated by spatial curvature. There seems to be no other escape.¹⁹⁸

After Hubble, all kinds of interesting objects and forces were being found in man’s telescope, e.g., quasars, gamma-ray and X-ray bursters, cosmic background microwave radiation, and a wide assortment of galaxies and star clusters. To the utter consternation of the world’s scientists, each of the newfound discoveries kept revealing the same piece of startling information – that Earth was right smack in the center of it all. In the words of astrophysicist [Yatendra P. Varshni](#) of the University of Ottawa who specialized in quasars:

The Earth is indeed the center of the Universe. The arrangement of quasars on certain spherical shells is only with respect to the Earth. These shells would disappear if viewed from another galaxy or quasar. This means that the cosmological principle will have to go. Also it implies that a coordinate system fixed to the Earth will be a preferred frame of reference in the Universe. Consequently, both the Special

¹⁹⁷ Albert Einstein and Leopold Infeld, *The Evolution of Physics*, New York, Simon and Shuster, 1938, 1966, pp. 154-155.

¹⁹⁸ *The Observational Approach to Cosmology*, Clarendon Press, 1937, pp. 50, 51, 58.

and General Theory of Relativity must be abandoned for cosmological purposes.¹⁹⁹

As one might expect from data that overturned the *status quo* of modern cosmology, the intrigue soon followed. Varshni was more or less ostracized by the science community until he capitulated to providing an alternative way of looking at the evidence, which he eventually did. But the milk, as they say, had already been spilt, and Varshni's "alternative" was not convincing to anyone. In fact, many astronomers after Varshni found the same evidence of an Earth-centered cosmos, and by this time it was quite difficult for the science community to keep them all quiet, even though we will never see these discoveries advertised by NASA or the CBS evening news.

As for NASA, while a third of the world goes to bed hungry at night, the space agency continues to consume billions of tax dollars for the sole purpose of trying to find evidence of life on other planets, for this, in their estimation, will finally vindicate modern science and show that all of life evolved from a primordial explosion; and that Earth is not something special but is merely a product of time and chance, resigned to spin around the universe like every other heavenly body. Their latest fallacious claims of finding the rudiments of life on Mars is just one example of the agenda lying just beneath the surface of their prestigious image.²⁰⁰

The connection between modern man's quest to deny the Earth a central place in the cosmos and the search for life on other planets was stated no better than in a recent article by *National Geographic*:

It's hard to overstate the excitement scientists feel at the prospect of seeing that faint blue dot. If it told of a watery, temperate place, humanity would face a 21st-century version of Copernicus's realization nearly 500 years ago that the Earth is not the center of the solar system. The discovery would show "that we're not in a special place, that we might be part of a continuum of life in the cosmos, and that life might be very common," says Michael Meyer, an astronomer at the University of Arizona.²⁰¹

¹⁹⁹ Y. P. Varshni, *Astrophysics and Space Science*, 43:3 (1976), p. 8.

²⁰⁰ See "Death knell for Martian life," *New Scientist*, December 21/28, 1996. Few noticed that NASA's claim to have found traces of primitive life on Martian rocks came at the same time NASA desperately needed government funding to continue its slated projects.

²⁰¹ Cited in "The History and the Pseudo-History of Science," by Gene Callahan, January 25, 2005.

Indeed, it is the quest of today's scientists to silence all challengers to modern cosmology. For them, the Earth must remain in the remote recesses of space so that mankind need not be troubled by the possibility that Someone is behind it all and a Someone to whom they must hold themselves accountable. This is, indeed, a high-stakes game and it is as old as the devil's temptation of Adam and Eve.

For the wrath of God is revealed from heaven against all
ungodliness and wickedness of men who by their
wickedness suppress the truth.

For what can be known about God is plain to them,
because God has shown it to them.

Ever since the creation of the world his invisible nature,
namely, his eternal power and deity, has been clearly
perceived in the things that have been made. So they are
without excuse;

for although they knew God they did not honor him as
God or give thanks to him, but they became futile in
their thinking and their senseless minds were darkened.

Romans 1:18-21

"Scientists are not the paragons of rationality, objectivity, openmindedness and humility that many of them might like others to believe."

Marcello Truzzi²⁰²

"...the tail is just as capable of wagging the dog in science as anywhere else."

Robert Laughlin²⁰³

The common idea that scientists reject a theory as soon as it leads to a contradiction is just not so. When they get something that works at all they plunge ahead with it and ignore its weak spots...scientists are just as bad as the rest of the public in following fads and being influenced by mass enthusiasm."

Vannevar Bush²⁰⁴

"Science is the culture of doubt."

Richard Feynman²⁰⁵

²⁰² Marcello Truzzi, former editor journal of The Committee for the Scientific Investigation of the Claims of the Paranormal, *The Skeptical Inquirer*.

²⁰³ Robert Laughlin, *A Different Universe, Reinventing Physics from the Bottom Down*, New York, Basic Books, 2005, p. 100.

²⁰⁴ Vannevar Bush, MIT Dean of Engineering (d. 1974).

²⁰⁵ Attributed.

"It is not uncommon for engineers to accept the reality of phenomena that are not yet understood, as it is very common for physicists to disbelieve the reality of phenomena that seem to contradict contemporary beliefs in physics."

Henry H. Bauer²⁰⁶

"Hypothesis...establishes itself by a cumulative process...if you make the same guess often enough it ceases to be a guess and becomes a scientific fact."

C. S. Lewis²⁰⁷

"The main source of the present-day conflicts between the spheres of religion and of science lies in this concept of a personal God."

Albert Einstein²⁰⁸

"Next in line are the scientists...they feel that they are the only men with any wisdom, and all other men float about as shadows....They can never explain why they always disagree with each other on every subject. In summation, knowing nothing in general they profess to know everything in particular."

Desiderius Erasmus²⁰⁹

²⁰⁶ Henry H. Bauer, professor emeritus of chemistry at Virginia Polytechnic in "The So-Called Scientific Method," in *Scientific Literacy and the Myth of the Scientific Method*, University of Illinois Press, 1992.

²⁰⁷ C. S. Lewis, *The Pilgrim's Regress*, Grand Rapids, W. B. Erdmans, 1958, p. 37.

²⁰⁸ Albert Einstein, *Ideas and Opinions*, New York, Crown Publishers, 1954, Wing Books, 1984, p. 47.

²⁰⁹ Erasmus' *The Praise of Folly*, translated by J. P. Dolan, p. 142.

Chapter 2

Science and Its Problems

Critical Remarks from Its Own Ranks

Today, science lives in the aura of being a monolithic consensus of truth and impartiality. Unfortunately, nothing could be further from the truth. Science, like any other project of man, is subject to the weal or woe of human participation and its common foibles. As science walks in the precarious halls of trial and error, it is, contrary to popular opinion, particularly prone to mistaken notions. As scientist Lewis Thomas (d. 1993) recently confided:

Science is founded on uncertainty....We are always, as it turns out, fundamentally wrong....The only solid piece of scientific truth about which I feel totally confident is that we are profoundly ignorant about nature.... It is this sudden confrontation with the depth and scope of ignorance that represents the most significant contribution of twentieth-century science to the human intellect.”²¹⁰

And again:

The principle discoveries in this [20th] century, taking all in all, are the glimpses of the depth of our ignorance about nature. Things that used to seem clear and rational, matters of absolute certainty – Newtonian mechanics for example – have slipped through our fingers, and we are left with a new set of gigantic puzzles, cosmic uncertainties, ambiguities. Some of the laws of physics require footnotes every few years, some are cancelled outright, some undergo revised versions of legislative intent like acts of Congress.²¹¹

²¹⁰ Lewis Thomas, “On Science and Certainty,” *Discover Magazine*, 1980, p. 58. Lewis also quips: “On any Tuesday morning, if asked, a good working scientist will tell you with some self-satisfaction that the affairs of his field are nicely in order, that things are finally looking clear and making sense, and all is well. But come back again on another Tuesday, and the roof may have just fallen in on his life’s work”; “In real life, every field of science is incomplete, and most of them – whatever the record of accomplishment during the last 200 years – are still in their very earliest stages.”

²¹¹ Lewis Thomas, “Making Science Work,” *Discover*, March 1981, p. 88.

[Karl Popper](#), one of the more respected secular philosophers, issued major critiques throughout his life on the industry of science. He writes:

For us therefore, science has nothing to do with the quest for certainty or probability or reliability. We are not interested in establishing scientific theories as secure or certain, or probable....It can even be shown that all theories, including the best, have the same probability, namely zero....the realization that our attempts to see and to find the truth are not final, but open to improvement; that our knowledge, our doctrine, is conjectural; that it consists of guesses, of hypotheses rather than of final and certain truths.²¹²

Since most people are not familiar with the intricacies of science, the doctrines concerning the mechanical workings of the universe are inevitably left to what modern society has come to know as “the scientist.” Those with credentials in theology, or even philosophy, are usually ignored when the crucial decisions are made regarding what will be taught in the universities. The sad truth is, however, that an inordinate number of scientists are employed for their own selfish interests, and never consider, let alone seek, an authority above themselves. Statistics reveal just how bad it has become. *Scientific American* carried an article a few years ago on the work of James H. Leuba, a statistician who both in 1914 and 1933 surveyed the religious beliefs of American biological and physical scientists regarding their views on two fundamental beliefs in Christianity: (1) the worship of God and (2) the existence of an afterlife. This study was important to Leuba since, as he said, “scientists enjoy great influence in the modern world, even in matters religious.”²¹³ At first glance, Leuba’s results seem somewhat reassuring. Among a general cross section of scientists, he found that 40% believed in God. But then he concentrated on the more elite scientists, those whose names are in the newspapers, who write the major books and articles, and who have the most influence on what the public believes. He found that an astonishing “80 percent of top natural scientists rejected both cardinal beliefs of traditional Christianity.” *Scientific American* then did its own study and found even worse results. Using the 1,800 members of the 1998 *National Academy of Sciences* as its measure of who comprised the “elite scientists” of the day, the editors found that:

²¹² Karl Popper, *Conjectures and Refutations: The Growth of Scientific Knowledge*, New York, Harpers and Row, 1963, 1965, pp. 229, 192, 151. Popper opens with: “The title of this lecture is likely, I fear, to offend some critical ears. For although ‘Sources of Knowledge’ is in order, and ‘Sources of Error’ would have been in order too...” (*ibid.*, p. 3).

²¹³ “Scientists and Religion in America,” Edward J. Larson and Larry Witham, *Scientific American*, September 1999, p. 89.

Disbelief among NAS members responding to our survey exceeded 90 percent...NAS biologists are the most skeptical, with 95 percent of our respondents evincing atheism and agnosticism. Mathematicians in the NAS are more accepting: one in every six of them [17%] expressed belief in a personal God.²¹⁴

Commenting further, the article shows that atheism is encouraged in academic circles, and those who have any Christian beliefs are quietly suppressed:

University of Washington sociologist Rodney Stark...points out, "There's been 200 years of marketing that if you want to be a scientific person you've got to keep your mind free of the fetters of religion."...higher education on the whole winnows out the idea of God or people who hold it. In research universities, "the religious people keep their mouths shut," Stark says. "And the irreligious people discriminate. There's a reward system to being irreligious in the upper echelons."²¹⁵

The reasons for this rampant atheism are then discovered:

Legendary evolutionary biologist Ernst Mayr, an NAS member since 1954, made a study of disbelief among his Harvard University colleagues in the academy. "It turned out we were all atheists," he recalls. "I found that there were two sources." One Mayr typified as, "Oh, I became an atheist very early. I just couldn't believe all that supernatural stuff." But others told him, "I just couldn't believe that there could be a God with all this evil in the world." Mayr adds, "Most atheists combine the two. This combination makes it impossible to believe in God."²¹⁶

How ironic is it that atheistic men are using religious and moral principles to judge whether God exists! With the audacity of a woman of the night, they dare blame God for the evil in the world.²¹⁷ Scripture has

²¹⁴ "Scientists and Religion in America," Edward J. Larson and Larry Witham, *Scientific American*, September 1999, p. 90.

²¹⁵ "Scientists and Religion in America," Edward J. Larson and Larry Witham, *Scientific American*, September 1999, p. 91.

²¹⁶ "Scientists and Religion in America," Edward J. Larson and Larry Witham, *Scientific American*, September 1999, p. 91.

²¹⁷ Proverbs 30:20: "Such is the way of an adulterous woman: she eats, wipes her mouth, and says, 'I have done no wrong.'"

quite a different story. It solemnly testifies that God blames man for the evil in the world. As Genesis 6:5-6 laments before the Great Flood:

The Lord saw that the wickedness of man was great in the earth, and that every imagination of the thoughts of his heart was only evil continually. And the Lord was sorry that he had made man on the earth, and it grieved him to his heart.

Thus, we would ask, rhetorically: who is right about the cause of the world's evil? Is it the scientist (as we will see later in Appendix 9 when we discuss the decadent lives of its most cherished icons), or is it God who cannot lie and declares in Romans 3:10-18:

There is none is righteous, no, not one; no one understands, no one seeks for God. All have turned aside, together they have gone wrong; no one does good, not even one. Their throat is an open grave, they use their tongues to deceive. The venom of asps is under their lips. Their mouth is full of curses and bitterness. Their feet are swift to shed blood, in their paths are ruin and misery, and the way of peace they do not know. There is no fear of God before their eyes.

Although there are many examples of atheist-driven scientific agendas in the halls of modern science today, one person who particularly fills that description in the field of cosmology is the late [Carl Sagan](#). One of the first exposures a novice has to the godless world of Sagan is this sad statement ascribed to one of his characters in his novel, *Contact*:

“If God is omnipotent and omniscient, why didn't he start the universe out in the first place so it would come out the way he wants? Why's he constantly repairing and complaining? No, there's one thing the Bible makes clear: The biblical God is a sloppy manufacturer. He's not good at design, he's not good at execution. He'd be out of business if there was any competition”²¹⁸

Autonomy was Sagan's gospel. As he himself stated: “First: there are no sacred truths...arguments from authority are worthless,”²¹⁹ and in the context Sagan is referring to religious authority. In its place, science

²¹⁸ Spoken by the character Sol Hadden, Carl Sagan, *Contact*, New York: Pocket Books, Simon and Shuster, 1985, 1997, p. 285. The prior sentences state: “If God didn't want Lot's wife to look back, why didn't he make her obedient, so she'd do what her husband told her? Of if he hadn't made Lot such a %&#head [expletive deleted], maybe she would've listened to him more.”

²¹⁹ Carl Sagan, *Cosmos*, New York: Random House, 1980, p. 333, and *Broca's Brain*, New York: Random House, 1979, p. 62.

has become a religion in its own right. In essence, it has been turned from science to *Scientism*. Its advocates preach its subjective beliefs just as strongly as any modern gospel evangelist. Whereas in the past the Church was the supreme authority, *Scientism* has no peer today. As it seeks converts, it presents as its foundation stone the Copernican revolution. In the words of Gunther Stent, a biologist at Berkeley:

In the wake of the publication of Darwin's *On the Origin of Species*, the idea of progress was raised to the level of a scientific religion.... This optimistic view came to be so widely embraced in the industrialized nations...that the claim that progress could presently come to an end is now widely regarded as outlandish a notion as was in earlier times the claim that the Earth moves around the sun.²²⁰

The public, pacified by such things as cell phones, antibiotics, jet planes, and computers, will rarely challenge the claims of modern science or attempt to upset the *status quo*, since whatever problems science may have, still, it makes our lives more comfortable than those who lived in the medieval era. But the sad fact is, except for a few basic ideas, today's science is very confused and it is at a loss to explain most of what it observes in nature, especially in the areas of cosmology and cosmogony. In most cases it is completely on the wrong track. As John Horgan notes:

...sometimes the clearest science writing is the most dishonest...Much of modern cosmology, particularly those aspects inspired by unified theories of particle physics and other esoteric ideas, is preposterous. Or, rather, it is ironic science, science that is not experimentally testable or resolvable even in principle and therefore is not science in the strict sense at all. Its primary function is to keep us awestruck before the mystery of the cosmos.²²¹

The universe is so complex and so bewildering that honest scientists are only too willing to admit that the more data scientific instruments attain, the more difficult becomes the task to make sense of it all. As astronomer [Fred Hoyle](#) summed it up: "The whole history of science shows that each generation finds the universe to be stranger than the preceding generation ever conceived it to be."²²² Biologist J. B. S.

²²⁰ Gunther Stent, *The Paradoxes of Progress*, San Francisco: W. H. Freeman, 1978, p. 27.

²²¹ John Horgan, *The End of Science: Facing the Limits of Knowledge in the Twilight of the Scientific Age*, New York: Broadway Books, 1997, pp. 93-94.

Haldane quipped: “The universe is not only queerer than we supposed, but queerer than we can suppose.” In brief, knowledge is abundant; but proper interpretation of the knowledge is severely lacking. Astronomer [Halton Arp](#) reminds us: “Really all we have for data in astronomy is photons as a function of x and y and frequency. The challenging puzzle is then to try to reason out how nature works,”²²³ and that, indeed, is a very difficult task without the proper guidance.

²²² Fred Hoyle, *Astronomy and Cosmology*, San Francisco, W. H. Freeman and Co, 1975, p. 48. Interestingly enough, Hoyle makes the comment in a context concerning whether the heliocentric or geocentric system is the correct model.

²²³ Halton Arp, *Seeing Red: Redshifts, Cosmology and Academic Science*, Montreal, *Aperion*, 1998, p. 208.

The Guardians at the Gate of Knowledge

Unfortunately, as scientists placate the populace with creature comforts, they have rather enjoyed the god-like status they have attained in the eyes of the adoring public. But the real truth is that today's gods of science fight amongst themselves just like the mythical gods of ancient Greece or Rome because, when all is said and done, they really know very little of what is going on in the universe. They have lots of information but in the main they are at a loss to make sense of it all. Everyone has an assortment of facts. Correct interpretation of the facts is the key to truth, and most scientists simply don't have that gift. The universe is simply too complex for their tiny theories.

Nevertheless, since almost everyone has been convinced that the Earth revolves around the sun, anyone who even attempts to espouse the opposite view is immediately classified as a *bona fide* lunatic; someone who still believes in a flat Earth and perhaps spends his day walking around with an aluminum foil hat on his head waiting for messages from outer space. Whatever their reasons, most scientists and layman will simply not consider the possibility of a motionless Earth in the center of the universe, no matter what the evidence shows them. If one should dare to persist and challenge them, they will not hesitate to become abusive.

As Thomas Kuhn observes:

During the century and a half following Galileo's death in 1642, a belief in the Earth-centered universe was gradually transformed from an essential sign of sanity to an index, first, of inflexible conservatism, then of excessive parochialism, and finally of complete fanaticism. By the middle of the seventeenth century it is difficult to find an important astronomer who is not Copernican; by the end of the century it is impossible...²²⁴

Or as Lakatos notes:

The Ptolamaists did their thing and the Copernicans did theirs and at the end the Copernicans scored a propaganda victory....Therefore the acceptance of the Copernican theory becomes a matter of metaphysical belief.²²⁵

People are set free by truth. Falsehoods keep them in darkness and force them to live in an illusion, under oppression, ultimately

²²⁴ Thomas S. Kuhn, *The Copernican Revolution*, New York, Random House, 1959, p. 227.

²²⁵ Imre Lakatos and Elie Zahar, "Why Did Copernicus' Research Program Supersede Ptolemy's," *The Copernican Achievement*, ed. Robert S. Westman, University of California Press, 1975, p. 367.

destroying them. Fortunately, man is blessed with an innate desire to find the truth, put there by his Creator. Often, however, this desire is difficult to satisfy because various ideologues of the world have a vested interest in keeping the rest of the human race in ignorance in order to advance their own atheistic agenda, while casting aspersions on those who reject their godless worldview. But as you read the evidence in this book, you might find yourself asking that haunting question: who, in fact, are the real lunatics? Are the lunatics people who have put their trust in divine revelation with a corresponding interpretation of scientific facts, or are they people like [Carl Sagan](#) who espouse such celestial gods as:

We are the local embodiment of a Cosmos grown to self-awareness. We have begun to contemplate our origins. We are star-stuff pondering the stars! Our ancestors worshipped the Sun, and they were not that foolish. It makes sense to revere the Sun and the stars, for we are their children.²²⁶

Indeed, the same thing happened among Sagan's "ancestors." As the Old Testament records:

All men are vain, in whom there is not the knowledge of God: and who by these good things that are seen, could not understand Him that is, neither by attending to the works have acknowledged who was the workman: But have imagined either the fire, or the wind, or the swift air, or the circle of the stars, or the great water, or the sun and moon, to be the gods that rule the world. With whose beauty, if they, being delighted, took them to be gods: let them know how much the Lord of them is more beautiful than they: for the first author of beauty made all those things. Or if they admired their power, and their effects, let them understand by them, that He that made them, is mightier than they: For by the greatness of the beauty, and of the creature, the Creator of them may be seen, so as to be known thereby.²²⁷

²²⁶ Carl Sagan, *Cosmos*, Random House, 1980, p. 243. As the rock icon Joni Mitchell sang: "I came upon a child of God / He was walking along the road / And I asked him, where are you going / And this he told me... / We are stardust, billion year old carbon. / We are golden. / And we've got to get ourselves back to the garden" (Woodstock, 1969). The Vatican's liberal-minded astronomer, Fr. George V. Coyne, S.J., said much the same in a recent interview: "There is no other way...to have the abundance of carbon necessary to make a toenail than through the thermonuclear processes in stars. We are all literally born of stardust" (*The Catholic Review*, 8-18-2005, p. A32). Suffice it to say, stellar "thermonuclear process" is an unproven science, and is now facing considerable contradictions from Plasma cosmology.

²²⁷ Wisdom 13:1-5 (RSV).

Coming from the same background, former cabinet member of the Clinton administration, [Robert Reich](#), knows who the real combatants are. In a recent article he stated:

The great conflict of the 21st century will not be between the West and terrorism. Terrorism is a tactic, not a belief. The true battle will be between modern civilization and anti-modernists; between those who believe in the primacy of the individual and those who believe that human beings owe their allegiance and identity to a higher authority; between those who give priority to life in this world and those who believe that human life is mere preparation for an existence beyond life; between those who believe in science, reason, and logic and those who believe that truth is revealed through Scripture and religious dogma.²²⁸

Reich, of course, is on the side of the modernists, the individualists, and the here-and-now autonomous logicians. In short, those who believe in God are Reich's enemies.

Why do men succumb to such alternatives when they know the path of truth and goodness? Scripture calls it "the *mystery* of iniquity," and, seeing how many terrible consequences men suffer because of their evil, to witness their continual denial of God is, indeed, a great mystery. Modern man seems to do whatever he can to make himself god-like so as to push the true God off the stage. In no better place is this evident than in modern man's cosmological theories. With a whisk of his mathematical wand, he, like God, can create any universe of his choosing. As physicist [J. J. Thomson](#) once noted:

We have Einstein's space, de Sitter's space, expanding universes, contracting universes, vibrating universes, mysterious universes. In fact the pure mathematician may create universes just by writing down an equation, and indeed if he is an individualist he can have a universe of his own.²²⁹

As astrophysicist Gerard de Vaucouleurs put it:

Less than 50 years after the birth of what we are pleased to call "modern cosmology," when so few empirical facts are passably well established, when so many different over-simplified models of the universe are still competing for attention, it is, may we ask, really credible to claim, or even reasonable to

²²⁸ Robert Reich, "The Last Word," *The American Prospect*, July 1, 2004.

²²⁹ *Einstein: Life and Times*, p. 301. Misner, Thorne and Wheeler list seven distinct universes that can come from changing the mathematical variables of General Relativity (*Gravitation*, p. 747), let alone the numerous variations of other models, such as the Steady State and Plasma universes.

hope, that we are presently close to a definitive solution of the cosmological problem?...Unfortunately, a study of the history of cosmology reveals disturbing parallelisms between modern cosmology and medieval scholasticism; often the borderline between sophistication and sophistry, between numeration and numerology, seems very precarious indeed. Above all I am concerned by an apparent loss of contact with empirical evidence and observational facts, and, worse, by a deliberate refusal on the part of some theorists to accept such results when they appear to be in conflict with some of the present oversimplified and therefore intellectually appealing theories of the universe...doctrines that frequently seem to be more concerned with the fictitious properties of ideal (and therefore nonexistent) universes than with the actual world revealed by observations.

He adds:

With few exceptions modern theories of cosmology have come to be variations on the homogeneous, isotropic models of general relativity. Other theories are usually referred to as 'unorthodox,' probably as a warning to students against heresy. When inhomogeneities [NB: theories that can lead to an Earth-centered universe] are considered (if at all), they are treated as unimportant fluctuations amenable to first-order variational treatment....But if nature refuses to cooperate, or for a time remains silent, there is a serious danger that the constant repetition of what is in truth merely a set of a priori assumptions (however rational, plausible, or otherwise commendable) will in time become accepted dogma that the unwary may uncritically accept as established fact or as an unescapable logical requirement. There is also the danger inherent in all established dogmas that the surfacing of contrary opinion and evidence will be resisted in every way.²³⁰

Much of today's confusion is due to the spooky world of Quantum Mechanics, which hasn't fared any better than Einstein's Relativity in making sense of it all. Faced with atomic particles that seem to have a mind of their own and don't obey the laws that the experimenters demand from them, today's scientists have left us with some of the wildest and most fantastic speculations and theories ever dreamed up by grown men. As Stephen Weinberg notes, "The techniques by which we decide on the acceptance of physical theories are extremely subjective."²³¹ Or as Robert Matthews reviews it:

²³⁰ Gerard de Vaucouleurs, "The Case for a Hierarchical Cosmology," *Science*, vol. 167, No. 3922, 1970, pp. 1203-1204.

²³¹ As quoted in an interview with John Horgan and cited in John Horgan, *The End of Science*, New York, Broadway Books, 1996, p.74. In the interview Horgan notes:

Take quantum theory, the laws of the subatomic world. Over the past century it has passed every single test with flying colours, with some predictions vindicated to ten places of decimals. Not surprisingly, physicists claim quantum theory as one of their greatest triumphs. But behind their boasts lies a guilty secret: they haven't the slightest idea why the laws work, or where they come from. All their vaunted equations are just mathematical lash-ups, made out of bits and pieces from other parts of physics whose main justification is that they seem to work.²³²

The newest twist for Quantum Mechanics is the “anthropic principle” wherein man becomes the creator of the universe because, it is claimed, his mere observation brings it into existence. Such self-deification, to create matter *ex nihilo* like God, is the ultimate quest of modern science.²³³

As Einstein made a wrong turn when he interpreted the Michelson-Morley experiment, so Quantum scientists took a dangerous detour when, after [Paul Dirac's](#) prediction and [Carl Anderson's](#) discovery of the positron, they concluded that matter and energy could be created and destroyed. Since this interpretation, even though it produced absurd results,²³⁴ helped save the reigning paradigm, it was all kept very quiet. The inventor of this methodology was physicist [Richard Feynman](#), but he was honest enough to admit that it was a “...shell game...Having to resort to such hocus-pocus...[it] is a dippy process.” Asked, then, why he was awarded the Nobel Prize, Feynman replied, “For sweeping them...under the rug.”²³⁵

“Weinberg retorted, in effect, that he does not see why we should be interested in a God who seems so little interested in us, however good he is at geometry” (*ibid.*, p. 77).

²³² Robert Matthews, *New Scientist*, 30, 1, 1999, p. 24.

²³³ John D. Barrow and Frank J. Tipler, *The Anthropic Cosmological Principle*, New York: Oxford University Press, 1986, pp. 677f. Nick Herbert, *Quantum Reality: Beyond the New Physics: An Excursion into Metaphysics and the Meaning of Reality*, New York: Anchor Books, c/o Doubleday, 1987, pp. 16-29. John A. Wheeler, “Bohr, Einstein, and the Strange Lesson of the Quantum,” *Mind and Nature*, ed., Richard Q. Elvee, New York: Harper and Row, 1981, pp. 18-20. George Greenstein, *The Symbiotic Universe: Life and Mind in the Cosmos*, New York: William Morrow, 1988, pp. 222-224.

²³⁴ The mathematics of the so-called “Standard Model” of the atom has the unfortunate anomaly of producing an electron with infinite rest mass. Since by other means science has determined the rest mass to be 0.511 MeV, it requires a “renormalization” of the Standard Model’s mathematics, namely, the 0.511 value is added in by hand, and no one is the wiser.

²³⁵ Quoted from James Gleick’s *Genius: The Life and Science of Richard Feynman*, New York: Vintage Books, 1992, reprint 1993, as cited in the article by D. L. Hotson

Irrespective of the exploits of the Quantum world, in the macro-world Copernican cosmology is the *sine qua non* of the science establishment. It goes by one of two names in today's scientific literature: *The Copernican Principle* (for those who are bold enough to admit the basis for their agenda), or *The Cosmological Principle* (for those who believe Copernicus is the foundation for modern science but choose labels that are less ostentatious). Whatever the name, it is a fact that no other scientific hypothesis comes close to the effect that removing the Earth from the center of the universe has had upon the thinking and aspirations of mankind. As we noted in chapter 1, Stephen Gould claimed that the common feature of all science is the removal of Earth from the center of the universe, and Stephen Hawking added that this removal has divested mankind of certainty, eternity, and absolutes. What a wonderful world they have created for themselves, a world in which they can be judged by nothing bigger than themselves.

Diametrically opposed to Gould's and Hawking's doctrine, of course, is the God of Scripture. The fact that man was placed in the center of the universe was apparently a very important piece of information to reveal to us, since the opening words of Genesis begin not with a detailed description about God, but about the Earth that God created before anything else, and which existed and furbished several days before the other celestial bodies were placed as its surrounding adornment.²³⁶ Unfortunately, men have long since forgotten Genesis, relegating it to the dustbin of myths and legends. In fact, with the coming and going of about a dozen or so cosmological theories since the time of Galileo, we will see that each one has systematically tried to eliminate the need for the Genesis Creator. In their pursuit, however, they soon found that each cosmology proposed by their best and brightest was seriously flawed, and, by their own calculations, men were stuck with the reality that the universe had a beginning, whether they liked it or not.

Still, they try to escape the inevitable and, like [Stephen Hawking](#), ask silly questions such as: "What place, then, for a creator?"²³⁷ Or, they seek to convince the public with absurd tautologies

"Dirac's Equation and the Sea of Negative Energy" *Infinite Energy*, Issue 43, 2002, p. 1. Concerning physics' newest brainchild, String Theory, Feynman states: "I am an old man now, and these are new ideas, and they look crazy to me, and they look like they're on the wrong track....I do feel very strongly that this is nonsense" (P. C. W. Davies and J. Brown, *Superstrings – A Theory of Everything*, Cambridge University Press, 1998, pp. 193-194).

²³⁶ "In the beginning God created the heavens and the earth. The earth was without form and void, and darkness was upon the face of the deep; and the Spirit of God was moving over the face of the waters. And God said, 'Let there be light'; and there was light."

²³⁷ Stephen Hawking, *A Brief History of Time: From the Big Bang to Black Holes* (Bantam Books, 1988), p. 141. In his second book Hawking expands on the idea, treating the universe as being god-like, without beginning or end: "The universe would

like those of [Carl Sagan](#): “A universe that is infinitely old requires no Creator.”²³⁸ In essence, infinity has become science’s god – a cold, impersonal, and unfathomable entity that mankind can neither comprehend nor is expected to repay in any way. Through these false gods man attempts to dethrone the true God of heaven and Earth. This quest is nothing new, of course. It was the very lie with which the devil tempted our first parents, saying: “God knows in the day you eat of it *you shall become as gods*, knowing good and evil.”²³⁹

The innate desire to imitate our Creator, which God has instilled in man as a worthy goal to attain, took a terrible detour with our first parents. Failing, however, to learn from this tragic lesson, modern man, including the ecclesiastics who have bowed themselves to science’s whims through the maze of “biblical criticism,” do everything they can to erase the existence of Adam and Eve from our collective consciences, preferring instead to believe that monkeys are our uncles. Instead of bowing before Him in respect of St. Paul’s admonition that “...ever since the creation of the world, His invisible attributes of eternal power and divinity have been able to be understood and perceived in what He has

be completely self-contained and not affected by anything outside of itself. It would neither be created nor destroyed. It would just BE. As long as we believed the universe had a beginning, the role of a creator seemed clear. But if the universe is really completely self-contained, having no boundary or edge, having neither beginning nor end, then the answer is not so obvious: what is the role of a creator?” (*A Briefer History of Time*, Bantam Dell, 2005, p. 103); later adding the naïve remarks: “Or does it need a creator, and if so, does He have any other effect on the universe? And who created Him?” (*ibid.*, p. 142). According to John Horgan: “There is no place, was his reply; a final theory would exclude God from the universe, and with him all mystery. Like Stephen Weinberg, Hawking hoped to rout mysticism, vitalism, creationism from one of their last refuges, the origin of the universe. According to one biographer, Hawking and his wife, Jane, separated in 1990 in part because she, as a devout Christian, had become increasingly offended by his atheism” (*The End of Science*, pp. 94-95). In another place Hawking wrote: “What I have done is to show that it is possible for the way the universe began to be determined by the laws of science. In that case, it would not be necessary to appeal to God to decide how the universe began. This doesn’t prove that there is no God, only that God is not necessary.” Sometimes Hawking seems to deify the universe, or attribute things to it that religion attributes to God alone. He writes: “Yet in another kind of time, the universe has no boundary. It is neither created nor destroyed. It just is....The inflation was a good thing in that it produced all the content of the universe quite literally out of nothing. When the universe was a single point, like the North Pole, it contained nothing” (*Black Holes and Baby Universes*, pp. 68, 97).

²³⁸ Carl Sagan, *Cosmos*, Random House, 1980, p. 249. See also Sagan’s contemptuous books against religion, e.g., *Broca’s Brain*, New York: Random House, 1979, and *Dragons of Eden*, New York: Random House, 1977.

²³⁹ Genesis 3:5.

made,”²⁴⁰ they make silly caricatures of God and, as St. Paul forewarns us, they “worship the creation rather than the Creator,”²⁴¹ as Carl Sagan proves for us:

The idea that God is an oversized white male with a flowing beard who sits in the sky and tallies the fall of every sparrow is ludicrous. But if by God one means the set of physical laws that govern the universe, then clearly there is such a God. This God is emotionally unsatisfying. It does not make much sense to pray to the law of gravity.²⁴²

Poor Carl. There is probably no better example of the dilemma of modern man than he. God, however, is no fool. As Scripture declares, He is never mocked.²⁴³ Anyone with a proper understanding of God, which he can quickly glean from even a cursory reading of the narratives of Scripture, will realize that He often gives man the godless world that he wants – as punishment for ignoring Him.²⁴⁴ In turn, He will laugh from heaven when their calamities strike.²⁴⁵ Dr. Gould, Dr. Sagan and Dr. Einstein, all of them now deceased, should have known these Scriptures very well, since at least those coming from the Old Testament were part of their formative years.²⁴⁶

²⁴⁰ Romans 1:20. As Immanuel Kant once noted: “Two things fill the mind with ever new and increasing wonder and awe...the starry heaven above me, and the moral law within me.”

²⁴¹ Romans 1:25.

²⁴² The quote is attributed to Sagan, but is invariably included among other quotes from Carl Sagan. Other interesting quotes attributed to Sagan include: “If we long to believe that the stars rise and set for us, that we are the reason there is a Universe, does science do us a disservice in deflating our conceits?...For me, it is far better to grasp the Universe as it really is than to persist in delusion, however satisfying and reassuring” (Carl Sagan, *The Demon-Haunted World: Science As a Candle in the Dark*, Random House, 1996). “In many cultures it is customary to answer that God created the universe out of nothing. But this is mere temporizing. If we wish courageously to pursue the question, we must, of course ask next where God comes from? And if we decide this to be unanswerable, why not save a step and conclude that the universe has always existed?” (Carl Sagan, *Cosmos*, p. 257).

²⁴³ Galatians 6:7 (“Make no mistake: God is not mocked, for a person will reap only what he sows”).

²⁴⁴ Cf. 2 Thessalonians 2:11; Romans 1:24-31; Numbers 11:18-20.

²⁴⁵ Psalm 37:13; 59:9; Proverbs 1:26; Habakkuk 1:10; Wisdom 4:18.

²⁴⁶ Sagan writes: “...as is plainly stated at every Rosh Hashonhan and every Jewish wedding ceremony, the Universe is less than 6,000 years old” (Carl Sagan, *The Demon-Haunted World: Science as a Candle in the Dark*, p. 325). Sagan would also be familiar with the following teaching in Deuteronomy 4:19: “And *beware* not to lift up your eyes to heaven and see the sun and the moon and the stars, all the host of heaven, and be

The bare truth is: if you act like an animal (which is the case when men pretend God doesn't exist), then God will allow you to believe that you descended from an animal. [Stephen Gould](#) reflects this very fact when he states that we have become “large reasoning animals” and we owe this to “our lucky stars.”²⁴⁷ Ironically, like pigs wallowing in the mud or dogs eating their own vomit, modern man seems all too comfortable with such demotion and degradation. He'll accept any hair brain idea, as long as it allows him to escape bowing down to an Almighty Being. Alan Rauch shows us why, and not surprisingly, it all goes back to the disdain for an Earth-centered cosmos:

Darwin's theory neatly summed up a view of the natural world that did not privilege any living thing over another. Instead, all organisms (including, by implication, humans) were subject to the physical forces of nature and, of course, to each other. Combined with new perspectives on space, time, and matter, *this view removed man from centrality in the universe*. The age-old idea that man was a creature revered by nature and favored by God could no longer be professed without serious misgivings.²⁴⁸

Although some scientists pay lip service to “searching for God,” in reality the quest of modern man has been a continual effort to remove God from the stage of human history. *Time* magazine, popular for its avant-garde liberalism, recently concluded concerning mankind's accomplishments in the last millennium:

Charles Darwin didn't want to murder God, as he once put it. But he did.... Darwinism remains one of the most successful scientific theories ever promulgated.²⁴⁹

In reality, the only thing successful about Darwinism is the propaganda machine it has cleverly devised to make people believe that rabbits actually come out of hats. Ever since the time of Galileo, man has tried to become a god by relying on his own knowledge and effort. Unfortunately, the more he does so, the more stupid he becomes and the further away he remains from becoming like God. This is the secret of life. Those who discover it are blessed, indeed. Those who refuse will be

drawn away and worship them and serve them, those which the LORD your God has allotted to all the peoples under the whole heaven.”

²⁴⁷ Stephen Gould, *Wonderful Life*, New York: W. W. Norton and Co., 1989, p. 318.

²⁴⁸ Alan Rauch, *Useful Knowledge: The Victorians, Morality And The March of Intellect*, Durham: Duke University Press, 2001, p. 12, emphasis added.

²⁴⁹ *Time*, December 31, 1999.

forever mired in futility and frustration. Even DNA discoverer James D. Watson admitted:

One could not be a successful scientist without realizing that, in contrast to the popular conception supported by newspapers and mothers of scientists, a goodly number of scientists are not only narrow-minded and dull, but also just stupid.²⁵⁰

In spite of this, science has become the weapon of choice for modern man in order to make himself the god of this world, answerable to no one but himself. But he only deceives himself. Although he fights to suppress it, inside each man God has instilled the knowledge that he will one day face judgment for his beliefs and actions. As Sirach assures us:

Much labor was created for every man, and a heavy yoke is upon the sons of Adam, from the day they come forth from their mother's womb till the day they return to the mother of all. Their perplexities and fear of heart – their anxious thought is the day of death, from the man who sits on a splendid throne to the one who is humbled in dust and ashes, from the man who wears purple and a crown to the one who is clothed in burlap; there is anger and envy and trouble and unrest, and fear of death, and fury and strife. And when one rests upon his bed, his sleep at night confuses his mind. He gets little or no rest, and afterward in his sleep, as though he were on watch, he is troubled by the visions of his mind like one who has escaped from the battlefield; at the moment of his rescue he wakes up, and wonders that his fear came to nothing.²⁵¹

²⁵⁰ Unfortunately, Watson was a religious skeptic. At the age of 74 he stated that religious explanations are “myths from the past....Every time you understand something, religion becomes less likely. Only with the discovery of the double helix and the ensuing genetic revolution have we had grounds for thinking that the powers held traditionally to be the exclusive property of the gods might one day be ours.” Crick and Watson boasted that their chief goal was to “discredit the existence of God.” Francis Crick (d. 2004), recently stated: “The God hypothesis is rather discredited....Archbishop Ussher claimed the world was created in 4004 B.C. Now we *know* it is 4.5 billion old. It's astonishing to me that people continue to accept religious claims. People like myself get along perfectly well with no religious views” (*London Daily Telegraph*, cited in *The Washington Times*, 3-24-2003). But in his more somber moments Crick admitted: “The origin of life appears almost a miracle, so many are the conditions which would have had to be satisfied to get it going....Every time I write a paper on the origin of life, I swear I will never write another one, because there is too much speculation running after too few facts.”

²⁵¹ Sirach (Ecclesiasticus) 40:1-7.

There have been three major attempts in the last five hundred years to make man's dream of removing God from the stage come true. The first was Copernicus' heliocentrism, the second was Darwin's evolution, and the third was Einstein's relativity. Modern scientists instinctively know that all three are immediately falsified if the Earth is motionless in the center of the universe. But if they are successful in dismissing that proposition as "unthinkable," these three theories will continue to rule the hearts of men like no other before them, each propped up by a pseudo-science that purports to know the real truth when in fact it knows very little. Each in its own right is a direct assault on what men previous to them believed to be true based upon a face value reading of the Old and New Testaments. As the modern scientific icon Paul Davies confirms for us:

Could this have happened without any supernatural input? Quantum physics seems to provide a loophole to the age-old assumption that "you can't get something for nothing." Physicists are now talking about "the self-creating universe": a cosmos that erupts into existence spontaneously...The question of whether the details of this theory are right or wrong are not so very important. It is now possible to conceive of a scientific explanation for all creation...Has modern physics abolished God altogether?²⁵²

The implication of Davies' statement is that modern physics has, indeed, abolished the need for God. Unfortunately, Davies is not alone. As we saw with Stephen Hawking's "what place, then, for a creator?" this convenient '*sine Deo et ex nihilo*' universe is a common belief among today's cosmologists.²⁵³ Being a little more honest about modern cosmology's naked emperor, astrophysicist **Andrei Linde** revealed why many have been forced to the absurd "something from nothing" position:

²⁵² Paul Davies, *God and the New Physics*, New York: Touchstone, Simon and Schuster, 1983, p. viii. In two letters sent to me, dated August 8-9, 2004, Davies confirmed my assessment of his views, stating: "In a nutshell, I have always argued against invoking any sort of God to create the universe in the big bang. I think physics can explain the big bang without supernatural input. The correct place to locate God-questions is in the laws of physics, not the initial conditions....I have long argued against the notion of any sort of God who resides within time, and who preceded the universe...The classical Christian doctrine of creation "ex nihilo" does NOT mean that God created the world at some moment in time as a temporal act. This is a mis-reading of classical theology" (Letters on file). Ralph Estling states that he also contacted Davies about this question. Estling writes: "I've had correspondence with Paul Davies on cosmological theory...I asked him what he meant by 'Nothing.' He wrote back that he had asked Alexander Vilenkin...and Vilenkin had replied, 'By Nothing I mean Nothing'" (*Skeptical Inquirer*, January/February, 1995, pp. 69-70).

²⁵³ Meaning: "Without God and out of nothing."

The first, and main, problem is the very existence of the Big Bang. One may wonder, What came before? If space-time did not exist then, how could everything appear from nothing? What arose first: the universe or the laws determining its evolution? Explaining this initial singularity – where and when it all began – still remains the most intractable problem of modern cosmology.²⁵⁴

A few physicists tried to answer the question. In 1973 Edward P. Tryon fired the first shot: “I proposed that our Universe had been created spontaneously from nothing, as a result of the established principles of physics.”²⁵⁵ Alan Guth of M.I.T. and Paul Steinhardt of Princeton followed in 1984 with an article stating:

The inflationary model of the universe provides a possible mechanism by which the observed universe could have evolved from an infinitesimal region. It is then tempting to go one step further and speculate that the entire universe evolved from literally nothing.²⁵⁶

More Big Bang theorists jumped on the bandwagon. Physicist John Gribbin followed two years later with these words: “the new

²⁵⁴ Andrei Linde, “The Self-Producing Inflationary Universe,” *Scientific American*, Magnificent Cosmos, 1998, p. 99. Linde then reveals five other problems with the traditional Big Bang theory. To overcome these, Linde posits that “energy in the scalar field” and “quantum fluctuations” produce all the proper ingredients in a super expansion. He writes: “Our universe appears smooth and uniform because all inhomogeneities were stretched $10^{10^{12}}$ – that is, a 1 followed by a trillion zeros.... This tremendous spurt immediately solves most of the problems of the old cosmological theory” (*ibid.* p. 101). But, he realizes this “may seem too good to be true. Indeed, if all inhomogeneities were stretched away, how did galaxies form? The answer is that while removing previously existing inhomogeneities, inflation at the same time made new ones.... The evolution of inflationary theory has given rise to a completely new cosmological paradigm, which differs considerably from the old Big Bang theory and even from the first versions of the inflationary scenario. In it the universe appears to be both chaotic and homogeneous, expanding and stationary. Our cosmic home grows, fluctuates and eternally reproduces itself in all possible forms, as if adjusting itself for all possible types of life” (*ibid.*, p. 102).

²⁵⁵ Edward P. Tryon, “What Made the World?” *New Scientist*, March 1984, p. 15. In another work he stated: “Our universe is simply one of those things which happen from time to time” (“Is the Universe a Vacuum Fluctuation?” *Nature*, 246, December 1973, pp. 396-397).

²⁵⁶ Alan Guth and Paul Steinhardt, “The Inflationary Universe,” *Scientific American*, May 1984, p. 128. To Guth, David Berlinski replied: “Thus, Alan Guth writes in pleased astonishment that the universe really did arise from ‘essentially nothing at all’... It would appear, then, that ‘essentially nothing’ has both spatial extension and mass. While these facts may strike Guth as inconspicuous, others may suspect that nothingness, like death, is not a matter that admits of degrees” (“Was There a Big Bang?” *Commentary*, February 1998, p. 37). Berlinski is a member of the Discovery Institute and a Ph.D. in philosophy from Princeton.

models are based on the concept that particles can be created out of nothing at all...matter might suddenly appear in large quantities.”²⁵⁷ Victor Stenger adds: “What caused it? Not everything requires a cause. It could have just happened spontaneously...”²⁵⁸ which led scientific satirist Terry Pratchett to conclude: “The current state of knowledge can be summarized thus: In the beginning, there was nothing, which exploded.”²⁵⁹ Or as Lynda Williams, professional entertainer and physics teacher at San Francisco State University, sang in her latest “Cosmic Cabaret”: “In the beginning, there was nothing” she whispers, and then “BIG BANG!” she screams.²⁶⁰ The *New York Times* concluded: “The only thing that all the experts agree on is that no idea works – yet.”²⁶¹

Finally, Linde answered his own question by positing that the universe “grows, fluctuates and eternally reproduces itself in all possible forms, as if adjusting itself for all possible types of life.”²⁶² Assertions such as these prove to us once again how cosmologists can create any universe they wish just by the stroke of a pen. Linde’s universe apparently has a mind of its own, in addition to being eternal. In his logic, one deals with the problem of the origin of the Big Bang by simply claiming that the Big Bang itself is eternal; that one Big Bang produces another Big Bang, *ad infinitum*. In short, the Big Bang becomes man’s god. That grown men would actually come to the point in which they speak of something coming from nothing, or matter having its own

²⁵⁷ John Gribbin, “Cosmologists Move Beyond the Big Bang,” *New Scientist*, 110, No. 1511, 1986, p. 30.

²⁵⁸ Victor Stenger, “Was the Universe Created,” *Free Inquiry* 7, 3, Summer, 1987, p. 26. Stenger was a physicist at the University of Hawaii. In a later publication, Stenger added: “The Universe revealed by science shows humanity as an infinitesimal speck in space and time with random with random chance as an important factor affecting events” (*Free Inquiry* 23, September 2003, p. 40)

²⁵⁹ Terry Pratchett, *Lords and Ladies*, New York, Harper Torch, 1996, p. 7.

²⁶⁰ Philip and Phylis Morrison, “The Big Bang: Wit or Wisdom?” *Scientific American*, February 2001, p. 93. After giving a short history of the repertoire of cosmological theories that have all been overturned, the Morrison’s add: “We simply do not know our cosmic origins; intriguing alternatives abound, but none yet compel. We do not know the details of inflation, nor what came before, nor the nature of the dark, unseen material, nor the nature of the repulsive forces that dilute gravity. The book of the cosmos is still open. Note carefully: we no longer see a Big Bang as a direct solution. Inflation erases evidence of past space, time and matter. The beginning – if any – is still unread. It is deceptive to maintain so long the very term that stood for a beginning out of nothing. The chanteuse will compose a clever new song once the case is clear” (*ibid.*, p. 95).

²⁶¹ “Before the Big Bang There Was...What?” *The New York Times*, May 22, 2001.

²⁶² Andrei Linde, “The Self-Producing Inflationary Universe,” *Scientific American*, Magnificent Cosmos, 1998, p. 102.

eternity, all in an effort to eliminate the biblical God as the miraculous *ex nihilo* Creator of the universe, is one of the surest signs of modern man's insanity. But this is the religion of *Scientism*, and its believers hold to it just as tenaciously as a Christian holds to Christianity.

For almost a thousand years, beginning from the time of Constantine in the early fourth century to the birth of Copernicus in the late fifteenth century, all men of godly heritage believed that the sun and stars revolved around the Earth; that all we see was created directly by God, and that the universe was limited and ordered. Ironically, modern man often calls this period of time (circa 400-1400 AD) the "Dark Ages" because of what they deem as "superstitious" beliefs, but, in reality, a more ominous Dark Ages began about 1400 AD with the advent of Copernicus, since man, spiritually speaking, has been on a steady decline ever since. True, man has invented many material things during this latter period that give the illusion of progress, but Scripture foresaw all of it and wasn't impressed. As God predicted to Daniel concerning our age:

Many shall run to and fro, and knowledge shall increase.... when the shattering of the power of the holy people comes to an end all these things would be accomplished.... the wicked shall do wickedly; and none of the wicked shall understand; but those who are wise shall understand.²⁶³

As the context reveals, however, this increased knowledge has only led man to accelerate and to magnify the evil residing in him, an evil that he has never conquered, but only camouflaged or ignored altogether. There are still barbarians today, only they use pens and computers rather than clubs and swords. When all is said and done, modern technology has only prompted man to do evil more quickly and efficiently, while he ignores God more boldly and pridefully than he ever did before, and *Scientism* has been his blind guide.

Solomon, the wisest of all men, put the attainment of knowledge into proper perspective:

...He has put eternity into man's mind, yet so that he cannot find out what God has done from the beginning to the end....And I saw every work of God, I concluded that man cannot discover the work which has been done under the sun. Even though man should seek laboriously, he will not discover it; and though the wise man should say, "I know," he cannot discover it.²⁶⁴

²⁶³ Daniel 12:4, 7, 10 (RSV).

²⁶⁴ Ecclesiastes 3:11; 8:17.

Fortunately, however, science is a two-edged sword. True science will never oppose God or His revelation to us, but today's scientists desperately want us to believe otherwise. Separating science from God is the ultimate quest of modern man.

Is Modern Science Corrupt?

Does modern man possess true science? The answer, in most cases, is no, especially in the field of cosmology. As the Russian Nobel Prize-winning physicist Lev Landau put it: “Cosmologists are often wrong, but never in doubt.” Or as [Halton Arp](#) noted: “After a ridiculously long time it has finally dawned on me that establishment scientists actually proceed on the belief that theories tell you what is true and what is not true.”²⁶⁵ Modern man has only made it appear as if he possesses the truth, since he has learned quite handily that only by giving such impressions can he rule the hearts of men. And that’s what it is all about – power over the people.

Most people are under the illusion that science is a monolithic consensus of truth and certainty. The reality is that science is subject to the same forces of fame, fortune, pride, position, politics, ignorance and bias as is any other venture of life. These human frailties often dictate the direction science will take, whether the course turns out to be right or wrong. M.I.T. professor Thomas Kuhn has shaken up quite a few of his scientific colleagues by pointing out these unpleasant realities. In his book *The Structure of Scientific Revolutions*²⁶⁶ he notes that personalities and politics play a large role in science and its theories. He concludes that scientists can never truly understand the real world, and they understand each other even less. Kuhn, the first to coin the word *paradigm* to describe the scientific process, reveals that scientists are molded in their thinking by the reigning models of the day, solving problems only within the accepted constraints, and rarely, if ever, challenging those constraints. He shows that the reigning paradigm at first appears to reconcile all experimental results. With time, anomalies begin to appear, which then give way to a new paradigm, but not without a long and arduous fight. As Fred Hoyle notes:

Science today is locked into paradigms. Every avenue is blocked by beliefs that are wrong, and if you try to get anything published in a journal today, you will run up against a paradigm, and the editors will turn you down.²⁶⁷

²⁶⁵ *Seeing Red: Redshifts, Cosmology and Academic Science*, Montreal, Aperia, 1998, p. 239.

²⁶⁶ Thomas Kuhn, *The Structure of Scientific Revolutions*, 3rd ed., University of Chicago Press, 1996.

²⁶⁷ *Scientific American*, “Profile: Fred Hoyle: The Return of the Maverick,” by John Horgan, March 1995, p. 47. In the same article, Horgan notes that, even though Hoyle had some “bizarre ideas,” *Nature* dubbed him “one of this century’s leading scientists.” Horgan begins his article with “...a special fear may creep into the hearts of scientists: What if Fred Hoyle is right? Then astronomy is a sham, biology a house of cards and modern medicine an illusion” (*ibid.*, p. 46).

Kuhn adds that anomalies in scientific experiments are often ignored, at least until so many of them accumulate that scientists are forced to find a new paradigm. Changes occur when someone young and not fully indoctrinated makes a successful bid to overcome past failures. Still, many adopt a new paradigm simply because it is supported by other scientists with strong reputations.

Reflecting on the views of Michael Polanyi, Catholic historian Philip Sherrard writes:

Other philosophers of science like Michael Polanyi have spoken of how impossible it is for the scientist not to be influenced by purely subjective factors such as what he expects to see, what other people have persuaded him that he should see, and so on – factors which mean that measurements of temporal and spatial intervals are not just given to the mind but are given to a particular mind deeply and inextricably involved with its own subjective personal prejudices and requirements.

In short, it could be argued that scientists themselves now admit that the best of their theories are but hypotheses, and that these, far from being reached inductively on the basis of objective data, as the old-fashioned empiricist would have it, are for the most part simply postulated as the most probable explanation or interpretation of certain data in accordance with a specific model which the scientist in question happens to have accepted.²⁶⁸

Going deeper into our subject, Sherrard compares modern science to Eastern mysticism:

Indeed, some scientists...claim that what they call the new physics has entirely emancipated itself from the mechanistic worldview of Cartesian and Newtonian physics and has in fact moved close to the worldview of Eastern mysticism. The two basic theories of modern physics – the quantum theory and the theory of relativity – exhibit...all the main features of the Eastern world view.²⁶⁹

Ultimately, if the ‘new physics’ has performed any positive service it is that it demonstrates more clearly than ever before the total incompetence of modern science to say anything about

²⁶⁸ Philip Sherrard, *The Rape of Man and Nature: An Enquiry into the Origins and Consequences of Modern Science*, Suffolk, Golgonooza Press, 1987, p. 74.

²⁶⁹ Philip Sherrard, *The Rape of Man and Nature: An Enquiry into the Origins and Consequences of Modern Science*, Suffolk, Golgonooza Press, 1987, p. 75.

the nature of the universe in which one can place any trust at all...their attempt to explain many phenomena by their examination of a few is a purely arbitrary process and cannot have anything to do with knowledge in the real sense of the word. Yet this on their own confession is all they are capable of doing: That all scientific theories and models are by definition approximations, and may be totally inadequate to convey a true picture of the reality with which they purport to be dealing, is a conclusion to which all modern scientific research is condemned by the premises from which it starts.²⁷⁰

Finally, an observation that relates directly to our present cosmological debate, Sherrard states:

In its turn, this revolution may be said to have two main characteristics, which are closely interconnected. The first is that it assumed that knowledge must be based on the observation of external phenomena: it must be based on sense-data without reference to the divine or indeed to any preconceived *a priori* ideas. The second is that it concluded that in order to reduce the data obtained from the observation of external phenomena to a coherent and reliable system of knowledge they must be submitted to the discipline of mathematics....The divorce between religion and philosophy is absolute: concern for the spiritual is banished from the study of physical phenomena and all scientific knowledge must be derived from the observation of a natural world regarded as a self-subsistent entity.²⁷¹

Astronomer [Tom van Flandern](#), once a card-carrying member of the scientific elite, writes how amazed he became when he discovered that almost every theory he had been taught in his professional career was wrong:

I particularly noted a regular practice of not re-examining the fundamental assumptions underlying a theory once it gained “accepted” status, almost no matter how incompatible some new observations or experiment might be. And I saw powerful vested interests in a “status quo” develop around certain accepted theories. It gradually became clear that a lot of people had a lot to lose if an accepted theory or practice were challenged; the authors of the original theory, whose names had become well-known; all those who published papers which

²⁷⁰ Philip Sherrard, *The Rape of Man and Nature: An Enquiry into the Origins and Consequences of Modern Science*, Suffolk, Golgonooza Press, 1987, p. 76.

²⁷¹ Philip Sherrard, *The Rape of Man and Nature: An Enquiry into the Origins and Consequences of Modern Science*, Suffolk, Golgonooza Press, 1987, p. 95.

reference or depend on the theory; journal editors and referees who have made decisions or criticized other works based on a theory; funding agencies which have paid for research which presupposes a theory; instrument builders and experiment designers who spend career time testing ideas which spring from a theory; journalists and writings whose publications have featured or promoted a theory; teachers and interested members of the public who have learned a theory, been impressed by the wonder of it, and who have no wish to have to teach or learn a new theory; and students, who need to find a job in their field of training. It has been my sad observation that by mid-career there are very few professionals left truly working for the advancement of science, as opposed to the advancement of self. And given enough people with strong enough interests, professional peer pressure takes over from there. Peer pressure in science, as elsewhere in society, consists of alternately attacking and ignoring the people who advocate a contrary idea, and discrediting their motives and/or competence, in order to achieve conformity.

Adding to the list of obstacles, Van Flandern speaks about specialization actually working against the attainment of scientific truth rather than fostering it:

As if there weren't already enough inertia to major changes of models, I see yet another phenomenon – new to our era of rapid progress in science – which mitigates against change even in the face of overwhelming need for it. Few scientists consider themselves qualified very far outside their own areas of expertise. Since each expert can account for only a small portion of the data dealing with a model, he defers to the other experts to support the model in other areas. Few, if any, scientists have the breadth of knowledge to see the full picture for a given model. So the model remains supported because many individual authorities support it, none of whom have the expertise to criticize the model overall, and all of whom have the utmost confidence in the others collectively. Authorities can continue to multiply indefinitely, with no one taking responsibility for integrating all their combined knowledge. As a result, the existing models get perpetuated regardless of merit or the extent of counter-evidence, because “so many experts can't all be wrong.” Thus each expert is persuaded to force-fit his own data into the accepted model.²⁷²

The truth is, not only does modern man know very little about true science, he makes a concerted effort to suppress true science when it

²⁷² Tom van Flandern, *Dark Matter, Missing Planets and New Comets*, rev. ed., Berkeley, CA: North Atlantic Books, 1993, pp. xvii-xviii.

conflicts with his pseudo-scientific presuppositions and personal agendas. When their errors can no longer be suppressed, scientists will eventually capitulate, resulting in theories that change every 50-100 years or so. As [Max Planck](#) once said: “Science proceeds funeral by funeral.”²⁷³ Rather than admitting their past failures, however, modern man hails the newest theory as evidence of his own intellectual prowess, until, of course, his new theory is eventually put on the chopping block and obliterated by the next genius.

After examining several cases of fraud in the science establishment, William Broad and Nicholas Wade made a thorough search into many of its claims. They provide us with the dismal results:

Our conclusion, in brief, is that science bears little resemblance to its conventional portrait...In the acquisition of new knowledge, scientists are not guided by logic and objectivity alone, but also by such nonrational factors as rhetoric, propaganda, and personal prejudice. Scientists do not depend solely on rational thought, and have no monopoly on it. Science should not be considered the guardian of rationality in society, but merely one major form of its cultural expression.²⁷⁴

Others have revealed the same corruption. Robert Bell, author of *Impure Science: Fraud, Compromise and Political Influence in Scientific Research*,²⁷⁵ is one of the better. As one reviewer states:

Bell shows time and again how the supposedly ‘objective’ scientific-research process is subverted by ego, infighting, and the lure of cold cash....Bell opens his well-researched account with a stunning attack on the scientific community’s sacrosanct system of ‘peer-review,’ which he says often means ‘review by

²⁷³ Anecdotal, and possibly an interpolation from his more complete remark: “A new scientific truth does not triumph by convincing its opponents and making them see the light, but rather because its opponents die and a new generation grows up that is familiar with it.” Max Planck’s physics teacher once advised him: “Physics is finished, young man. It’s a dead-end street,” then advised Planck to become a concert pianist instead” (Nick Herbert, *Quantum Reality*, p. 31). A similar statement comes from Mark Twain: “When the human race has once acquired a superstition, nothing short of death is ever likely to remove it” (Autobiography of Mark Twain).

²⁷⁴ *Betrayers of the Truth*, William Broad and Nicholas Wade, New York: Simon and Schuster, 1982, pp. 8-9. Broad and Wade point out the problems with “peer review” (pp. 18-21, 89-102), faulty data collection (pp. 107-125), desire for advancement and continuation of government funding (pp. 88-106), non replication of experiments (pp. 60-87), *status-quo* obstacles (pp. 126-160), protecting popular scientists and pet projects from scrutiny (pp. 161-180), personal agendas (pp. 181-211). Broad and Wade uncover many discrepancies and problems with Galileo, Newton, Einstein, Darwin, and many other scientists involved with cosmological issues.

²⁷⁵ Robert Bell, *Impure Science: Fraud, Compromise and Political Influence in Scientific Research*, New York, John Wiley and Sons, 1992.

one's competition' in today's highly competitive world of scientific research...all too often peer review simply becomes a process by which powerful, well-established scientists can reward their friends and frustrate their rivals...the greatest problem in today's scientific community may well be fraud...particularly in the field of medical research, has resulted in deadly drugs being left on the market and faulty heart valves being implanted in people's chests.²⁷⁶

The problems haven't lessened since Wade (1982) and Bell (1992) revealed their statistics. Horace Judson, from my alma mater, George Washington University, published *The Great Betrayal: Fraud in Science* in 2004 showing that the problems are much worse than two decades ago. As the title denotes, Judson concentrates on the problem of fraud. As the reader digests the case studies Judson presents, he often has to reposition his jaw from the constant downward reflex it is prone to assume.²⁷⁷ Recently, researcher Woo Suk Hwang dazzled the world with

²⁷⁶ Simon Garfinkel, "When Fraud Taints Science," *Christian Science Monitor*, July 1992.

²⁷⁷ Horace F. Judson, *The Great Betrayal: Fraud in Science*, Harcourt, Inc., Orlando, Florida, 2004, p. 463. A recent article titled "Most Scientific Papers are Probably Wrong" in *Science Medicine* says: "Most published scientific research papers are wrong, according to a new analysis. Assuming that the new paper is itself correct, problems with experimental and statistical methods mean that there is less than a 50% chance that the results of any randomly chosen scientific paper are true. John Ioannidis, an epidemiologist at the University of Ioannina School of Medicine in Greece, says that small sample sizes, poor study design, researcher bias, and selective reporting and other problems combine to make most research findings false. But even large, well-designed studies are not always right, meaning that scientists and the public have to be wary of reported findings. 'We should accept that most research findings will be refuted. Some will be replicated and validated. The replication process is more important than the first discovery,' Ioannidis says. In the paper, Ioannidis does not show that any particular findings are false. Instead, he shows statistically how the many obstacles to getting research findings right combine to make most published research wrong. Massaged conclusions: Traditionally a study is said to be 'statistically significant' if the odds are only 1 in 20 that the result could be pure chance. But in a complicated field where there are many potential hypotheses to sift through - such as whether a particular gene influences a particular disease - it is easy to reach false conclusions using this standard. If you test 20 false hypotheses, one of them is likely to show up as true, on average. Odds get even worse for studies that are too small, studies that find small effects (for example, a drug that works for only 10% of patients), or studies where the protocol and endpoints are poorly defined, allowing researchers to massage their conclusions after the fact. Surprisingly, Ioannidis says another predictor of false findings is if a field is "hot", with many teams feeling pressure to beat the others to statistically significant findings. But Solomon Snyder, senior editor at the Proceedings of the National Academy of Sciences, and a neuroscientist at Johns Hopkins Medical School in Baltimore, US, says most working scientists understand the limitations of published research. 'When I read the literature, I'm not reading it to find proof like a textbook. I'm reading to get ideas. So even if something is wrong with the paper, if they have the

his claims of cloning human embryonic stem cells, until he was forced to admit that he fabricated all of it.²⁷⁸ For years the medical establishment told its patients that low-fat diets helped reduce stroke, heart disease and other such vascular maladies, but within a few short weeks into the year 2006 the same establishment told us that those studies were all erroneous based on the evidence from even “newer studies.”²⁷⁹ For years men and women advanced in years were told to take calcium supplements to strengthen their bones, and once again the year 2006 brought us the sad news that science, true to form, took a wrong turn, since other “studies” found that taking calcium supplements not only doesn’t strengthen the bones but increases the risk of other maladies. Where will it all end?

kernel of a novel idea, that's something to think about,' he says.” (Journal: Public Library of Science Medicine, DOI: 10.1371/journal.pmed.0020124).

See also: Richard Milton, *Forbidden Science: Exposing the Secrets of Suppressed Research*, Cox and Wyman Ltd., Great Britain, 1994; Anthony Standen, *Science is a Sacred Cow*, London, Sheed and Ward, 1952; E. P. Dutton Publishers, 2000. Standen writes: “Physics is *not* a body of indisputable and immutable Truth; it is a body of well-supported probable opinion only, and its ideas may be exploded at any time” (p. 49).

²⁷⁸ “Con Men in Lab Coats” *Scientific American*, March 2006, p. 10.

²⁷⁹ “Low-Fat Diet Falls Short,” *Science News*, February 11, 2006, vol. 169, p. 85.

The Changing Tide

So often we hear in the media of intellectuals in academia and the science community who ridicule those who take the Old and New Testaments at face value. With much ingratiating self-satisfaction they claim that literal interpretations of Scripture have been forever banished, since we have all come to accept that the Earth revolves around the sun. Once “biblical criticism” paved the way for scholars to ignore Scripture’s testimony that the Earth had no movement, it was only a matter of time before the next biblical pillar – a six-day creation – would be attacked and suppressed, along with a global flood and the Genesis genealogies to the first man that stretched no longer than about 10,000 years.

Beginning around the mid-1900s, things began to change in the world of science, however. It was at this time that those who accepted Scripture both as divine revelation and at face value, began to delve more deeply into the sciences than ever before. They began to see that a proper interpretation of scientific facts did not preclude a non-evolutionary origin for the Earth or a non-uniformitarian development of its terrain, but actually supported it much better than the opposing evolutionary views. There has been so much information made available that we are beginning to see universities and secondary schools take a second look at these issues. For example, the Intelligent Design argumentation has proven itself to be one of the more formidable weapons against evolutionary theory in the ongoing wars of cosmogony. Of course, the opposition against creationism and catastrophism has mounted in proportion, since many of today’s secular scientists refuse even to consider alternatives to their cherished atheistic evolutionary theories. As Oxford biologist Richard Dawkins put it: “Darwin made it possible to be an intellectually fulfilled atheist,” or as Richard Lewontin admitted:

It is not that the methods and institutions of science somehow compel us to accept a material explanation of the phenomenal world, but, on the contrary, that we are forced by our a priori adherence to material causes to create an apparatus of investigation and a set of concepts that produce material explanations, no matter how counterintuitive, no matter how mystifying to the uninitiated. Moreover, that materialism is absolute, for we cannot allow a Divine Foot in the door.²⁸⁰

But *Galileo Was Wrong* will not be addressing the arguments against evolution. Many well-qualified secular and biblical scientists

²⁸⁰ “Billions and Billions of Demons,” *The New York Review of Books*, January 9, 1997, pp. 28, 31.

have done their job quite well in refuting its precarious tenets. Our book will deal solely with the issue of Earth-centered cosmology, a subject that, unfortunately, many of the aforementioned biblical scientists have been somewhat reluctant to address, let alone support, perhaps for fear of appearing like the uneducated Neanderthals and stubborn academics that their evolutionary opponents accuse them of being.

Strengths and Weaknesses in the Catholic Hierarchy

Most Catholics today, including the present Vatican hierarchy, have been unnecessarily stigmatized by the Galileo affair. The Pontifical Academy of Science, commissioned in 1979 by [John Paul II](#) to do an investigation into Galileo's life and work, suppressed both Galileo's conversion to geocentrism and the scientific evidence demoting heliocentrism from its 500-year pedestal. Instead, they propped up Galileo as a martyr for the cause of both science and theology. But this turn of events is not surprising considering the composition of the Pontifical Academy of Science. It has approximately one hundred members, some of whom are avowed atheists, and all of whom have accepted the Darwinian and Copernican hypotheses, making it known to the world that they will entertain no other theories. Consequently, the Academy has fed the Catholic Magisterium a number of dubious interpretations about Galileo and cosmology in general, which, unfortunately, has led the public to think that the Vatican is apologizing to Galileo, while at the same time raising unfounded doubts and criticisms about the beliefs and motives of the many popes and cardinals who censored Galileo for his unproven scientific beliefs in the seventeenth century. As a result, most prelates have been very tepid about questioning the theories of modern science for fear of embroiling the Church in another "Galileo embarrassment." In their fear they have capitulated to the beliefs of the religion of *Scientism* and have more or less disowned their rich and stable Catholic heritage. They have chosen to play the conciliatory card, convincing themselves that science and ecclesiastics are finally dancing in tandem; and there exist precious few who have the courage to rock the boat. But it is high time for the Catholic Church to wake up to her posterity, for without it she is slowly being seduced. As Slote said to Natalie in the *The Winds of War*: "Christianity is dead and rotting since Galileo cut its throat."²⁸¹ Hence, the Church's wake-up call is long overdue.

The truth is, as this book will show, the Catholic Church of yesteryear was absolutely correct in censoring Galileo and rejecting the Copernican system. Although most Catholic apologists have made an art out of inventing excuses for the popes and cardinals who condemned Galileo's theories (with the implicit motivation "to save face" for the Church), it remains an undeniable fact of history that the Catholic Church put the official weight of its magisterium behind the condemnation of Copernicanism. As even the agnostic evolutionist Thomas Huxley admitted in a letter to Catholic priest George Mivart, speaking about the famous book by Fr. William Roberts in the late 1800s (Robert's positing that the condemnations against Galileo were infallible):

²⁸¹ Herman Wouk, *The Winds of War*, Pocket Edition, 1973, p. 610.

In your paper about scientific freedom, which I read some time ago with much interest, you alluded to a book or article by Father Roberts on the Galileo business. Will you kindly send me a postcard to say where and when it was published? I looked into the matter when I was in Italy, and I arrived at the conclusion that the Pope and the College of Cardinals had rather the best of it. It would complete the paradox if Father Roberts should help me to see the error of my ways. –Ever yours very faithfully, T. H. Huxley.²⁸²

As mentioned in our Introduction, and we repeat here for emphasis, on April 12, 1615, [Robert Cardinal Bellarmine](#) wrote a personal letter to Paolo Antonio Foscarini who had been advocating the heliocentric view for some time. Among other points, in the letter Bellarmine makes this emphasis:

Second, I say that, as you know, the Council prohibits interpreting Scripture against the common consensus of the Holy Fathers; and if Your Reverence wants to read not only the Holy Fathers, but also the modern commentaries on Genesis, the Psalms, Ecclesiastes, and Joshua, you will find all agreeing in the literal interpretation that the sun is in heaven and turns around the earth with great speed, and that the earth is very far from heaven and sits motionless at the center of the world. Consider now, with your sense of prudence, whether the Church can tolerate giving Scripture a meaning contrary to the Holy Fathers and to all the Greek and Latin commentators.

With Foscarini in view as the convicted, on February 24, 1616 an ecclesiastical commission of eleven clerics (most of them cardinals) under the direction of Cardinal Bellarmine, condemned Copernicanism as “formally heretical” and that “contradicts the express wording of Scripture in many places.”²⁸³ On February 26, 1616, [Pope Paul V](#)

²⁸² T. H. Huxley, *Letters and Diary 1885*, November 12, 1885.

²⁸³ Original Latin: “Prima: Sol est centrum mundi, et omnino immobilis motu locali” (Translation: “First: The sun is in the center of the world, and is completely immobile in its location”). “Censura: Omnes dixerunt, dictum propositionem esse stultam et absurdam in philosophia, et formaliter haeticam, quatenus contradicit expresse sententiis Sacrae Scripturae in multis locis secundum proprietatem verborum et secundum communem expositionem et sensum Sanctorum Patrum et theologorum doctorum” (Translation: “Censored: We declare, the stated proposition is foolish and absurd in philosophy, and formally heretical, inasmuch as it contradicts the express wording of Sacred Scripture in many places, according to the meaning of the words and the common interpretation and sense of the Fathers and the doctors of theology”). “2. Terra non est centrum mundi nec immobilis, sed secundum se totam movetur, etiam motu diurno” (Translation: “The Earth is not the center of the universe nor immobile, but is itself completely moved, and also moves diurnally”). “Censura: Omnes dixerunt, hanc propositionem recipere eandem censuram in philosophia; et spectando veritatem

ordered Bellarmine to summon Galileo to Rome and, “in the presence of a notary and witnesses lest he should prove recusant, warn him to abandon the condemned opinion and in every way abstain from teaching, defending or discussing it.”²⁸⁴ This was followed by a formal decree issued by the *Sacred Congregation of Cardinals under Pope Paul V, Authorized by the Apostolic Chair to the Index of Forbidden Books* on March 5, 1616 containing six explicit paragraphs reiterating the condemnation not only of the book written by “Nicolaus Copernicus” but, more deeply, the original Greek inventors of heliocentrism as represented by

...the false doctrine of Pythagorus, concerning the mobility of the Earth and the immobility of the sun, as completely adversarial to the divine Scriptures.²⁸⁵

In the midst of these events, Galileo wrote to Cardinal Bellarmine in May 1616 asking for a clarification of what occurred in the March 1616 session and whether the injunction applied to him personally, prompting Bellarmine to write a certificate for Galileo saying that, at that specific time, he was neither forced to renounce his opinions nor punished for them, but that he was:

...informed of the declaration made by his Holiness and published by the Sacred Congregation of the Index, in which it

theologicam, ad minus esse in Fide erroneam” (Translation: “We declare, this proposition receives the same censure in philosophy, and in regard to its theological truth, it at least is erroneous in Faith”). (Antonio Favaro, *Galileo e l’Inquisizione, Documenti de Processo Galileiano...per la prima volta integralmente pubicati*, Florence, 1907, p. 61).

²⁸⁴ Dorothy Stimson, *The Gradual Acceptance of the Copernican Theory of the Universe*, New York, Baker and Taylor, 1917, p. 58. Favaro has the following: “...supradictus P. Commissarius praedicto Galileo adhuc ibidem praesenti et constituto praecepit et ordinavit [proprio nomine] S. D. N. Papae et totius Congregationis S. Officii, ut supradictam opinionem, quod sol sit centrum mundi et immobilis et terra moveatur, omnino relinquat, nec eam de caetero, quovis modo, teneat, doceat aut defendat, verbo aut scriptis; alias, contra ipsum procedetur in S. Officio. Cui praecepto idem Galileus acquievit et parere promisit” (Antonio Favaro, *Galileo e l’Inquisizione, Documenti de Processo Galileiano...per la prima volta integralmente pubicati*, Florence, 1907, p. 62).

²⁸⁵ “Decretum: Sacrae Congregationis Illustrissimorum S.R.E. Cardinalium, a S.D.N. Paulo Papa V Sanctaque Sede Apostolica ad Indicem librorum...falsam illam doctrinam Pithagoricam, divinaeque Scriptureae omnino adversantem, de mobilitate terrae et immobilitate solis, quam Nicolaus Copernicus De revolutionibus orbium coelestium...” Added to the condemnation were: “Didacus Astunica,” “Padre Maestro Paolo Antonio Foscarini Carmelitano” and “Lazzaro Scoriggio” in the most explicit and repetitive language condemning any advocacy of the immobility of the sun and the mobility of the Earth (Antonio Favaro, *Galileo e l’Inquisizione, Documenti de Processo Galileiano...per la prima volta integralmente pubicati*, Florence, 1907, pp. 62-63).

is stated that the doctrine attributed to Copernicus – that the earth moves around the sun and that the sun stands in the center of the world without moving from the east to the west – is contrary to the Holy Scriptures and therefore cannot be defended nor held.²⁸⁶

The letter from Bellarmine would prove to be an important document since it later served as evidence against Galileo seventeen years later in 1633 when [Pope Urban VIII](#) reminded him that he was under strict orders not to teach the heliocentric system, which decree Galileo had apparently broken many times since 1616. In April 1633, the pope thus forced him to renounce his views and Galileo was required to write a detailed abjuration.²⁸⁷ Urban then sent a formal letter to the inquisitors and papal nuncios of Europe announcing Galileo's abjuration and requiring them to heed the Vatican's condemnation of Copernicanism.²⁸⁸ Thirty-one years later when the talk of Copernicanism was still prevalent, in 1664, [Pope Alexander VII](#) attached condemnations of the works of Copernicus, Galileo, and Kepler to a papal bull appropriately titled *Speculatores domus Israel* ("Spies in the

²⁸⁶ Original Italian: "...ma solo gl'è stata denunciata la dichiarazione fatta da Nostro Signore et publicata dalla Sacra Congregazione dell' Indice, nella quale si contiene che la dottrina attribuita al Copernico, che la terra si muova intorno al sole et che il sole stia nel centro del mondo senza muoversi da oriente ad occidente, sia contraria alle Sacre Scritture, et però non si possa difendere nè tenere" signed by Bellarmine on May 26, 1616 (Antonio Favaro, *Galileo e l'Inquisizione, Documenti de Processo Galileiano...per la prima volta integralmente pubicati*, Florence, 1907, pp. 82, 88).

²⁸⁷ Antonio Favaro, *Galileo e l'Inquisizione, Documenti de Processo Galileiano...per la prima volta integralmente pubicati*, Florence, 1907, pp. 76-85; 142-151.

²⁸⁸ Stimson writes: "On the third of March the Cardinal reported to the Congregation in the presence of the Pope that he had warned Galileo and that Galileo had acquiesced. The Congregation then reported its decree suspending 'until corrected' 'Nicolai Copernici De Revolutionibus Orbium Caelestium, et Didaci Astunica in Job,' and prohibiting 'Epistola Fratris Pauli Antonii Foscarini Carmelitae,' together with all other books dealing with this condemned and prohibited doctrine. The Pope ordered this decree to be published by the Master of the Sacred Palace, which was done two days later" (Dorothy Stimson, *The Gradual Acceptance of the Copernican Theory of the Universe*, New York, Baker and Taylor, 1917, p. 59-60). Stimson adds: "Pope Urban had no intention of concealing Galileo's abjuration and sentence. Instead, he ordered copies of both to be sent to all inquisitors and papal nuncios that they might notify all their clergy and especially all the professors of mathematics and philosophy within their districts, particularly those at Florence, Padua and Pisa. This was done during the summer and fall of 1633" (*ibid.*, p. 68). But Gingerich adds: "Then a very interesting result emerged, something the Inquisitors never knew. Roughly two-thirds of the copies [of *De revolutionibus*] in Italy were censored, but virtually none in other countries, including Catholic lands such as Spain and France....In fact, the Spanish version of the Index explicitly permitted the book!" (*The Book that Nobody Read*, p. 146).

House of Israel”), signed by the pope himself.²⁸⁹ Obviously, the pope wanted to protect the Church from the “spies” who were trying to infiltrate its walls.

Interestingly enough, the Catholic Church has always permitted the Copernican system as a “hypothesis,” beginning from the 1616 decree under Paul V and continuing through to 1820 under Pius VII and beyond.²⁹⁰ The original magisterial condemnation stated that, once [corrections were made](#), the heliocentric view could be presented as a hypothesis but *not as a scientific fact*, which was affirmed again in 1620 by a separate decree that has never been modified or rescinded.²⁹¹ As

²⁸⁹ *Index Librorum Prohibitorum et Expurgandorum Novissimus, Pro Catholicis Hispaniarum*, Regnis Philippi IV, Regis Cathol., Ill., AC. R. D.D. Antonii A Sotomaioir O.P., Supremi Præfidis, & in Regnis Hifpaniarum, Siciliae, & Indiarum Generalis Inquifitoris, c. juffu ac ftudiis, luculenter & vigilantiffimè recognitus, Madriti [Madrid], Ex Typographæo Didaci Diaz, Subfignatum Lldo Huerta, M. DC. LXVII [1667]. “*Index Librorum Prohibitorum, Alexandri Septimi [Alexander VII] Pontificis Maximi juffu editus: Copernicanæ Aftronomiæ Epitome. vide, Ioannis Kepleri; Copernicus. vide, Nicolaus.*” (p. 30); “Galileo Galilei. *Vide, Dialogo di Galileo.*” (p. 52); “Ioannis Keppleti Epitome Aftronomiæ Copernicanæ” (p. 73), attached to: “...Bullam Alexandri VII, P. M. qualis est in limine Editonis Superioris Anni, qui est M, DC, LXIV [1664]. Nam licèt nonnulla contineat, quæ ad illam Editionem, ejusque dispositionem speciatim pertinent, non sufficiebat tamen ea ratio, vt ejus lectione non fruerentur hic Fideles. Alexander Papa VII, Ad perpetua rei Memoriam. Speculatores Domus Israel...” (p. 137).

²⁹⁰ On August 16, 1820 a petition to write and publish about the Copernican theory was sent to the Vatican on behalf of Professor Jacob Settele. The petition reads: “Circa petitionem Professoris Iacobi Settele a SS.^{mo} remissam huic Sacred Congregationi, pro permissione impressionis sui operas super doctrina mobilitatis terrae...” (“Concerning the petition of Professor Jacob Settele sent to the Sacred Congregation for permission to have an edition of our work about the doctrine of the motion of the earth...”). On September 11, 1822, the Sacred Congregation gave a reply: “E.mi DD. Decreverunt, non esse a præfenti et futuris pro tempore Magistris Sacri Palatii Apostolici recusandam licentiam pro impressione et publicatione operum tractantium de mobilitate terrae et immobilitate solis iuxta communem modernorum astronomorum opinionem, dummodo nihil aliud obstet, ad formam Decretorum Sacrae Congregationis Indicis anni 1757, et huius Supremæ anni 1820 reluctantes et inobedientes, prævia, quatenus opus sit, derogatione prætensorum privilegiorum, coercendos esse poenis arbitrio S. Congregationis...” (“They have resolved not, in the present or future, to refuse a license for the editing and publication of works discussing the mobility of the earth and the immobility of the sun akin to the common opinion of modern astronomers...”) (Antonio Favaro, *Galileo e l’Inquisizione, Documenti de Processo Galileiano...per la prima volta integralmente publicati*, Florence, 1907, pp. 30-31). Two things are of note here: (a) Pius VII does not sign the license, and (b) the Sacred Congregation refers to the mobility of the earth as merely “the *common opinion* of modern astronomers,” which shows that the Church was still allowing Copernicanism to be put forward as a hypothesis or opinion, but certainly not as scientific fact.

²⁹¹ “Monito per l’emendazione dell’ opera De revolutionibus orbium caelestium di Niccolò Copernico, Roma, 15 maggio 1620” in which [nine corrections](#) were amended. One example of a correction, as illustrated in the link above, regards Copernicus’ statement in Book 1, Chapter 9: “Cum igitur nihil prohibet mobilitatem terra, videndum nunc arbitror, an etiam plures illi motus convenire ut poffint una errantium siderum

such, the seventeenth century decrees remain, heretofore, the highest declarations the Church has issued on the subject of heliocentrism concerning what is, and what is not, allowed to be believed by obedient Catholics. That being the case, there simply is no room for any faithful Catholic to assert Copernicanism *as a scientific fact*. In that regard, nothing has changed since the days of Galileo, for Galileo was also permitted to treat Copernicanism as a hypothesis, but *not as a scientific fact*.²⁹² Unfortunately, modern theologians are all too willing to sweep these crucial distinctions under the proverbial rug, yielding to the unmitigated pressure from the world's scientific elite. Most have forgotten or ignored the warning issued by [Pope Pius X](#):

You see clearly, Venerable Brethren, how mistaken are those who think they are doing service to the Church, and producing fruit for the salvation of souls, when by a kind of prudence of the flesh they show themselves liberal in concessions to science falsely so called [1Tim 6:20], under the fatal illusion that they are thus able more easily to win over those in error, but really with the continual danger of being lost themselves. The truth is one, and it cannot be halved; it lasts for ever, and is not subject to the vicissitudes of the times.²⁹³

Catholic scientist, author and former M.I.T. professor Wolfgang Smith writes:

Today, four centuries later, what lay concealed in that beginning has become clearly manifest, for all to see; as Arthur

enuntiare” (“Therefore since nothing hinders the mobility of the Earth, I think we should now see whether more than one movement belongs to it, so that it can be regarded as one of the wandering stars”), as appearing in the edition of *De Revolutionibus* by Nicolai Mulerii, Amsterdam, 1617. Mulerii shows the line in which the censor crossed out the above sentence and changed it in the margin to: “Cum igitur terram moveri assumpserim, videndum nunc arbitror, an etiam illi plures possint convenire motus...” (Therefore, with the assumption that the earth moves, I think we should now see whether more than one movement belongs to it...)”) The correction is noted also in Favaro’s *Galileo e l’Inquisizione, Documenti de Processo Galileiano...per la prima volta integralmente pubblicati*, Florence, 1907, p. 141. Gingerich notes the correction in Book 1, chapter 11, from Galileo’s personal copy of *De revolutionibus* which reads: “De triplici motu telluris demonfratio” (“The Demonstration of the Three-Fold Motion of the Earth”) was crossed out and replaced with “De hypothesi triplicis motus terre ciusq demonstratione” (“The Hypothesis of the Three-Fold Motion of the Earth and its Demonstration”).

²⁹² Gingerich adds this possible motivation: “*De revolutionibus* included observations of the Sun and Moon, of potential value to the Church, so it was inadvisable to ban the book outright. Nor could the heliocentrism simply be excised, for it was too firmly embedded in the text. The only path was to change a few places to make it patently obvious that the book was to be considered strictly hypothetical” (*The Book that Nobody Read*, p. 144).

²⁹³ Pops Pius X, encyclical of March 12, 1904, *Iucunda Sane*, 25.

Koestler has said, it is “as if a new race had arisen on this planet.” Could this be the reason why St. Malachy, in his famous prophecies, has characterized the reign of Pope Paul V (1605-1628) by alluding to the birth of “a perverse race”? One needs to recall that what is sometimes termed the first Galileo trial took place in the year 1616. What, then, could be the “perverse race” to which the saintly prophet refers? Given that Galileo is indeed “the father of modern science,” one is compelled to answer that it is none other than the race of modern scientists, and by extension, the community of individuals imbued with the modern scientific outlook....

As everyone knows, Galileo was formally tried in 1633 and forced to recant his Copernican convictions. The proposition that the Sun constitutes the immobile center of the universe was declared to be “formally heretical, because it is expressly contrary to the Holy Scriptures.” And so the matter stood until 1822, when, under the reign of Pius VII, the Church commenced to soften its stand with regard to what it termed “the general opinion of modern astronomers.” Thus began a process of accommodation with “the new race” which came to a head in 1979, when Pope John Paul II charged the Pontifical Academy of Sciences to re-open the Galileo case, and if need be, to reverse the verdict of 1633. Given the mentality which came to the fore in the wake of Vatican II, the outcome of that inquiry was never in doubt: Galileo was exonerated – some would say, “canonized” – following which Pope John Paul II in effect apologized to the world for wrongs committed by the Church. Could this be the reason, perhaps, why St. Malachy alludes to this Pope in the enigmatic words “*De Labore Solis*”? To be sure, the phrase, which traditionally refers to the movement of the Sun, does relate to Galileo, the man who denied that the Sun does move. Could it be, then, that St. Malachy, having previously signaled the birth of a “perverse race,” is now alluding to the fact that some four hundred years later the Church has reversed its stand and relinquished its opposition to that “race,” which is to say, to that new philosophy? Certainly St. Malachy’s allusion can be interpreted in other ways as well; for example, “*De Labore Solis*” might be taken as a reference to the fact that this Pope, who has traveled far more extensively than any of his predecessors, has so many times “circled the globe” in his papal airliner (named, interestingly enough, “Galileo”).

But be that as it may, the fact remains that the Church has now joined the rest of Western society in adopting a scientific worldview; during the reign of Pope John Paul II, and with his sanction, a Copernican Revolution has finally taken place within the Church itself. Yet, to be precise, it is not the Church as such that has undergone change – that has “evolved,” as the expression goes – but what has changed is simply the

orientation of its human representatives: it is Rome, let us say, that has reversed its position. Humanly speaking, the ecclesiastic establishment may have opted for the only viable course: given the sophistication and prowess of contemporary science – given the “great signs and wonders” that could deceive even the elect – it may not indeed be feasible to stem the mounting tide of scientific belief. Nonetheless one must insist, in light of our preceding analysis, that the contemporary cosmology, in any of its forms, is not in fact compatible with Christian doctrine. To the extent, therefore, that Rome has embraced a scientific outlook, it has compromised the true teaching of the Church: this is the crux of the matter. Call it human failing, call it “political correctness,” call it apostasy – the fact is that Rome has become “a house divided against itself.”²⁹⁴

Earlier in his book Dr. Smith writes concerning the fact that geocentrism is a science:

If there has been little debate in recent times on the subject of geocentrism, the reason is clear: almost everyone takes it for granted that the geocentrist claim is a dead issue, on a par, let us say, with the flat-Earth hypothesis. To be sure, the ancient doctrine has yet a few devoted advocates in Europe and America, whose arguments are neither trivial nor uninformed; the problem is that hardly anyone else seems to care, hardly anyone is listening. Even the biblically oriented creation-science movement, which of late has gained a certain prestige and influence, has for the most part disavowed geocentrism. The fact remains, however, that geocentrist cosmology constitutes not only an ancient, but indeed a traditional doctrine; should we not presume that as such it enshrines a perennial truth? To maintain, moreover, that this truth has nothing to say on a cosmographic plane – that the doctrine, in other words, is “merely symbolic or allegorical” – to think thus is to join the tribe of theologians who are ever willing to “demythologize” at the latest behest of the scientific establishment. It will not be without interest, therefore, to investigate whether the geocentrist claim – yes, understood cosmographically! – had indeed been ruled out of court. I shall urge that it has not. As regards the Galileo controversy, I propose to show that Galilean heliocentrism has proved to be

²⁹⁴ Wolfgang Smith, *The Wisdom of Ancient Cosmology: Contemporary Science in Light of Tradition*, Oakton, VA: Foundation for Traditional Studies, 2003, pp. 180-181. Dr. Smith’s other works include: *Cosmos and Transcendence* (1984), *Teilhardism and the New Religion* (1988), and *The Quantum Enigma* (1995).

scientifically untenable, and that in fact the palm of victory belongs to the wise saintly Cardinal Bellarmine.²⁹⁵

Perhaps there may be a few who will see the truth, but, the world's scientists, by and large, are the last on our list of concerns. We do not expect those whose careers, salaries, and Nobel Prizes depend upon supporting Copernicanism, Evolution, and Relativity to their dying breath, will ever consider that the Earth is motionless and in the center of the universe. As noted earlier, an immobile Earth in the center of the universe would destroy all three legs of *Scientism's* stool in one fell swoop. Sadly, rather than prompting such men to lift their eyes in awe, the information gathered herein may only harden their hearts even more, and thus serve as a testimony against them when they meet their Maker. As such, our audience is geared to the next generation of scientists and theologians who are tired of the cosmological shell game that has been going on for the last several centuries.

In closing this chapter, let us say that, in spite of the harsh criticisms we levy against modern scientists, we are not disparaging their intellects. The halls of science house some of the most intelligent men this world has ever known. One glance at their mathematical equations and we know we are not dealing with ordinary human beings. Most of these men are geniuses. But the sad fact is, it doesn't matter how smart you are, how many books you've written, what chairs of science or mathematics you hold, how many Nobel prizes you've won, or how popular you are. The difficult but undeniable truth is: if you start out with the wrong premise, you are going to end up with the wrong conclusion. With the wrong answers, as the saying goes, 'you may be able to fool some of the people some of the time, but you cannot fool all the people all of the time.' The advantage this work has is that it starts with the right premise, for it obtained that premise from divine revelation and was not afraid to accept it at face value, and now all that is left is to work backwards, as it were, and verify the premise by using the very tools with which modern man prides himself: science, math, and logic. As Scripture assures us: "But thou hast arranged all things by measure and number and weight."²⁹⁶

²⁹⁵ Wolfgang Smith, *The Wisdom of Ancient Cosmology: Contemporary Science in Light of Tradition*, Oakton, VA: Foundation for Traditional Studies, 2003, p. 149.

²⁹⁶ Wisdom 11:20 [Douay-Rheims: 11:21].

The heavens are telling the glory of God; and the
firmament proclaims his handiwork.
Day to day pours forth speech, and night to night
declares knowledge.
There is no speech, nor are there words; their voice is not
heard;
yet their voice goes out through all the earth, and their
words to the end of the world. In them he has set a tent
for the sun,
which comes forth like a bridegroom leaving his
chamber, and like a strong man runs its course with joy.
Its rising is from the end of the heavens, and its circuit
to the end of them; and there is nothing hid from its
heat.

Psalm 19:1-6 [18:1-6]

"Wrong is wrong even if everybody's doing it, and right is right, even if nobody's doing it."

St. Augustine

"Physics is much too difficult for physicists."

David Herbert²⁹⁷

"One may understand the cosmos, but never the ego; the self is more distant than any star."

G. K. Chesterton²⁹⁸

"...we are at the center of a series of explosions. This is an anti-Copernican embarrassment."

Halton Arp²⁹⁹

²⁹⁷ As cited in *Hilbert* by Constance Reid, New York, Springer-Verlag, 1907, p. 127. Hilbert helped develop the theory of Relativity.

²⁹⁸ G. K. Chesterton, *Orthodoxy*, New York, Doubleday, 1957, p. 54.

²⁹⁹ *Seeing Red: Redshifts, Cosmology and Academic Science* (Montreal, Aperia, 1998), p. 195 (emphasis added).

Chapter 3

The “Intolerable” Evidence Earth: The Center of the Universe

Edwin Hubble

The possibility that Earth is at the center of the universe was swirling in the minds of scientists for quite a while in the last century. In chapter 1 we made a brief survey of the scientific consensus beginning with [Edwin Hubble](#), and here we will add the detail.

Hubble was one of the 20th century’s most famous and celebrated astronomers. The *Hubble Space Telescope* is named after him, for his accomplishments were astounding. To his utter consternation, however, in the 1930s and 40s, Hubble discovered an inordinate amount of evidence through his work with the 100-inch telescope at Mount Palomar, California, that Earth was in the center of the universe. As he examined the light coming from stars, Hubble concluded that the spectrum of light, particularly the shift toward the red end of the spectrum, indicated Earth’s centrality quite clearly. But since Hubble was an avowed Copernican, he dismissed the geocentric evidence and countered with the following obstinate alternative:

...Such a condition would imply that we occupy a unique position in the universe, analogous, in a sense, to the ancient conception of a central Earth...This hypothesis cannot be disproved, but it is unwelcome and would only be accepted as a last resort in order to save the phenomena. Therefore we disregard this possibility...the unwelcome position of a favored location must be avoided at all costs... such a favored position is intolerable....Therefore, in order to restore homogeneity, and to escape the horror of a unique position...must be compensated by spatial curvature. There seems to be no other escape.³⁰⁰

Notice Hubble’s highly charged language. Although he admits it cannot be disproved, an Earth-centered universe is not only “unwelcome” but “must be avoided at all costs” and, in fact, it is a “horror” that is “intolerable.” As noted earlier, one scientist even calls it a “depressing thought.”³⁰¹ Notice also Hubble revealing to us that “space curvature” was invented (by Einstein) in order to escape the geocentric

³⁰⁰ *The Observational Approach to Cosmology*, Oxford, Clarendon Press, 1937, pp. 50, 51, 58.

³⁰¹ Donald Goldsmith, *The Evolving Universe*, Menlo Park, CA, The Benjamin/Cummings Publishing Company, 1985, p. 140.

implications from the evidence in his telescope of Earth's centrality. We will cover more of this issue in later chapters.

It is not difficult to conclude that the most gifted scientists of our day simply cannot overcome their prejudices and presuppositions when examining evidence that upsets their world-view. The thought of having to make an apology for the fact that science had misled the world for so many years is, indeed an "intolerable...horror" for today's scientists as well as it was for Hubble. As Van der Kamp observes:

For theoretical thinking and concluding are not self-sufficient. When – as it has happened! – a prominent astronomer tells us that scientifically the Tychonian [geocentric] system of the world cannot be disproven, but that philosophically it is unacceptable, then he bares thereby the pre-rational foundation of all human thought to be the starting point of his convictions. And that starting point determines his approach to his scientific labors, whether he is fully aware of it or not...his faith in human thinking's self-sufficiency misleads him into believing that this thinking can provide him with an unassailable truth.³⁰²

Mighty telescopes and super-sensitive scanners may deliver reams and reams of data – they deliver not a syllable of unassailable interpretation. At bottom we always see, as Wittgenstein put it, what we want to see. That is in astronomy: either a closed finite, an open finite, or a curved unbounded cosmos.³⁰³

James Burke, in his book describing how Galileo changed our whole outlook on the world, states:

Today we live according to the latest version of how the universe functions. This view affects our behavior and thought, just as previous versions affected those who lived with them. Like the people of the past, we disregard phenomena which do not fit our view because they are 'wrong.' Like our ancestors we know the real truth.

Has the course of learning about the universe been, as science would claim, a logical and objective search for the truth, or is each step taken for reasons related only to the theories of the time? Do scientific criteria change with changing social priorities? If they do, why is science accorded its privileged position? If all research is theory-laden, contextually determined, is knowledge merely what we decided it should

³⁰² *De Labore Solis*, p. 56.

³⁰³ *De Labore Solis*, p. 80.

be? Is the universe what we discover it is, or what we say it is?³⁰⁴

And later, to the question of what a geocentric universe would look like, Burke adds:

The point is that it would look exactly the same. When we observe nature we see what we want to see, according to what we believe we know about it at the time.³⁰⁵

Perhaps feeling the pressure upon him in light of the overwhelming evidence in his telescope, just prior to the end of his book Hubble took a cosmic swipe at Relativity and Dark Matter, and the universe that both entities envision:

Thus the theory might be valid provided the universe were packed with matter to the very threshold of perception. Nevertheless, the ever-expanding model of the first kind seems rather dubious. It cannot be ruled out by the observations, but it suggests a forced interpretation of the data. The disturbing features are all introduced by the recession factors, by the assumption that red-shifts are velocity-shifts. The departure from a linear law of red-shifts, the departure from uniform distribution, the curvature necessary to restore homogeneity, the excess material demanded by the curvature, each of these is merely the recession factor in another form...if the recession factor is dropped, if red-shifts are not primarily velocity-shifts, the picture is simple and plausible. There is no evidence of expansion and no restriction of the time-scale, no trace of spatial curvature, and no limitation of spatial dimensions. Moreover, there is no problem of inter-nebular material [today's "Dark Matter"].³⁰⁶

Hubble said much the same for the Royal Astronomical Society:

If the redshifts are a Doppler shift...the observations as they stand lead to the anomaly of a closed universe, curiously small and dense, and, it may be added, suspiciously young. On the other hand, if redshifts are not Doppler effects, these anomalies disappear and the region observed appears as a small,

³⁰⁴ James Burke, *The Day the Universe Changed: How Galileo's Telescope Changed the Truth and Other Events in History That Dramatically Altered Our Understanding of the World*, New York: Little, Brown and Co., 1985, preface.

³⁰⁵ James Burke, *The Day the Universe Changed*, p. 11.

³⁰⁶ *The Observational Approach to Cosmology*, p. 63.

homogeneous, but insignificant portion of a universe extended indefinitely in both space and time.³⁰⁷

To use an old cliché, we might say that Hubble was caught between a rock and a hard place. If he admits that redshift is a Doppler effect, then he is forced to an Earth-centered universe that is “closed, small, dense and young.” If he opts for the position that redshift is not a Doppler effect, he is left with an infinite universe that does not run by the Big Bang theory or even the theory of General Relativity. The bare truth is, here we have one of the greatest astronomers the world has ever known admitting possibilities from his telescopic observations that are completely opposed to the views held today by modern astronomy. Of course, the first view suggesting an Earth-centered universe was “intolerable” for Hubble, which is probably the reason that just before his death in 1953 he confided to Robert Millikan (1923 Nobel Prize winner) that redshift should not be interpreted as a Doppler shift, and thus Hubble led the way for the emergence of the Steady State theory in the 1960s.

Stephen Hawking

[Stephen Hawking](#), probably the world’s most famous living physicist, found himself in the same dilemma as did Hubble regarding the position of the Earth in the universe. He writes:

...all this evidence that the universe looks the same whichever direction we look in might seem to suggest there is something special about our place in the universe. In particular, it might seem that if we observe all other galaxies to be moving away from us, then we must be at the center of the universe.³⁰⁸

Since Hawking must give equal credibility to [Alexander Friedmann’s](#) first assumption (i.e., that the universe looks identical in whichever direction we look), he cannot deny the clear implications of that assumption – that the Earth is in the center of it all. In order to

³⁰⁷ *Monthly Notices of the Royal Astronomical Society*, 17, 506, 1937.

³⁰⁸ *A Brief History of Time*, Bantam Books, New York, 1988, p. 42. Hawking says the same on page 47: “This could mean that we are at the center of a great region in the universe...” The book was published on April Fool’s Day in 1988, six years after he started writing it. Since then it has been translated into thirty languages and has sold close to 10 million copies. A film has also been made as well as another book, *A Brief History of Time: A Reader’s Companion*. The latest edition, *The Illustrated A Brief History of Time*, has been translated into forty different languages and sold more than 10 million copies. This book was on the *London Sunday Times* Best Seller list for a record two hundred and thirty seven weeks, longer than any other book. Hawking adds, however, that this does not include Shakespeare or the Bible. Hawking recently published his updated sequel: *A Briefer History of Time*, Bantam Books, 2005.

attempt an escape from this implication, Hawking proposes an “alternate explanation”:

There is, however, an alternate explanation: the universe might look the same in every direction as seen from any other galaxy, too. This, as we have seen, was Friedmann’s second assumption. We have no scientific evidence for, or against, this assumption. We believe it only on grounds of modesty: it would be most remarkable if the universe looked the same in every direction around us, but not around other points in the universe.³⁰⁹

Since Hawking admits he has no irrefutable evidence for his alternative, his resorting to Friedmann’s second assumption rather than the first assumption is obviously an arbitrary decision. The criterion for his choice, he says, is based on “modesty.” In other words, Hawking wants us to believe that, of the two assumptions, he is purposely choosing the one that removes Earth from the center of the universe based on what he understands as the human virtue of taking the most humble position. This has become a common apologetic among secular cosmologists. Hawking isn’t the first. In 1972, W. B. Bonnor, faced with deciding between a homogeneous non-centered and an inhomogeneous centered universe, stated:

It seems that [$\rho \propto (\text{distance})^{-1.7}$], if extrapolated indefinitely, is at variance with the Cosmological Principle as ordinarily understood, since it implies that the Universe has a center at the present time....Nevertheless, that we happen to find ourselves so near the center is uncomfortable for human modesty.³¹⁰

³⁰⁹ *A Brief History of Time*, p. 42. Hawking is not the first to appeal to the “modesty” position. Hawking’s dependence on the “Cosmological Principle” to vindicate his position was appropriately critiqued by Van der Kamp: “...the cosmological principle...has about the same logical status as the view of an Indian in the Amazon jungles who concludes that, since he sees parrots in the palms, there must be parrots at the Poles” (*Bulletin of the Tychonian Society*, Jan-Feb, 1979, p. 7). Hawking suggests there is a mysterious connection to the fact that he was born three hundred years, to the day, after Galileo’s death. Accordingly, he is profuse with his admiration of Galileo: “Galileo, *perhaps more than any other single person*, was responsible for the birth of modern science. His renowned conflict with the Catholic Church was central to his philosophy, for Galileo was *one of the first to argue* that man could hope to understand how the world works, and, moreover, that we could do this by observing the real world” (*ibid.*, p. 179, emphasis added). It was Hawking’s desire to emulate his three favorite scientists in *A Brief History of Time*, and thus he writes three short essays on Einstein, Galileo, and Newton, respectively. In each essay, Hawking reveals his deep-seated, ideological motivations and treats the three scientists as if they were persecuted saints.

³¹⁰ W. B. Bonnor, “A Non-Uniform Relativistic Cosmological Model,” *Monthly Notices of the Royal Astronomical Society*, 1972, 159, p. 261. Bonnor was reacting to the article written by Gerard de Vaucouleurs titled: “The Case for a Hierarchical Cosmology,” *Science*, February 27, 1970, vol. 167, No 3922, p. 1203-1213, arguing that the position

In reality, this is merely a feigned humility; an attempt to engender the sympathies of the human audience so that the astronomer can appear noble and self-deprecating, and therefore more convincing; a way of making oneself appear gallant by choosing the less ingratiating option when in reality the choice is made simply in order to avoid the divine implications and harsh demands of an Earth in the center of everything. As we noted earlier from the remarks of Stephen Gould, man has been on a relentless quest since the days of Copernicus to keep Earth away from center of the universe, for the science community knows full well that admitting to a special place for the Earth means that Someone higher than us must have deliberately put it in that privileged position. Hawking more or less admits his motivations when he writes elsewhere:

We could still imagine that there is a set of laws that determines events completely for some supernatural being, who could observe the present state of the universe without disturbing it. However, such models of the universe are not of much interest to us ordinary mortals.³¹¹

Still, Hawking is not completely comfortable with the position he has adopted. Like a boy who steals from his mother's cookie jar and gorges himself in the serene satisfaction that he was able to outsmart her, he soon discovers that his stomach is upset and his whole body racked with pain. So Hawking second guesses his own philosophy:

It was quite a shift in our view of the universe: If we are not at the center, is our existence of any importance? Why should

of galaxies in the universe is no accident, but follows a hierarchial pattern, implying creation by design.

³¹¹ *Ibid.*, p. 55. Interestingly enough, Stephen Hawking sees in the Big Bang an affiliation with religion, since it implies a beginning to the universe. He writes: "Many people do not like the idea that time has a beginning, probably because it smacks of divine intervention. (The Catholic Church, on the other hand, seized on the big bang model and in 1951 officially pronounced it to be in accordance with the Bible.)" Suffice it to say, we will deal with Hawking's claims about "official" teachings of the Catholic Church in the second volume of *Galileo Was Wrong*. For now, we can say that his claims are fallacious. In order to escape the notion of a beginning, Hawking has invented the "no boundary" cosmos, wherein the universe is a "wave-function" that merely "popped" into existence. Hawking arrives at this understanding by the use of "imaginary" time, although he admits that "When one goes back to the real time in which we live...there will still appear to be singularities....In real time, the universe has a beginning and an end at singularities that form a boundary to space-time and at which the laws of science break down" (*ibid.*, p. 139). This is the kind of dream world in which today's scientists dabble, and yet they write about it in their books as if it is a reality all to itself; and the gullible audience accepts it with little question, for they also, having removed God from the picture, have no other choice but to accept the fantasies of modern science.

God or the laws of nature care about what happens on the third rock from the sun, which is where Copernicus has left us? Modern scientists have out-Copernicused Copernicus by seeking an account of the universe in which man (in the old pre-politically correct sense) played no role. Although this approach has succeeded in finding objective impersonal laws that govern the universe, it has not (so far at least) explained why the universe is the way it is rather than being one of the many other possible universes that would also be consistent with the laws....Many people (myself included) feel that the appearance of such a complex and structured universe from simple laws requires the invocation of something called the anthropic principle, which restores us to the central position we have been too modest to claim since the time of Copernicus.³¹²

Perhaps, as the old saying goes, Hawking wants to have his cake and eat it, too. He doesn't want to accept that the Earth is in the center of the universe, but he would like it just the same if science could figure out some way of *restoring* it to the center without it actually *being* in the center. Until that wishful thinking becomes a reality, the "alternate" explanation for what scientists of his imagination see in their telescopes seems to be the mantra they have all adopted to escape an Earth-centered cosmology.

Robert Dicke

The inner motivations and cosmological rationalizations of astronomer [Robert Dicke](#) are eerily similar to Hawking's:

Particularly significant in the distribution of galaxies about us is uniformity and isotropy. The galaxies appear to be uniformly distributed about us. Not only is the distribution uniform but the above described motions with respect to us represent a uniform dilation. How is this to be interpreted? We might be tempted to conclude that man occupies some special central point in the Universe, that galaxies move away from *us*. An alternative interpretation is that the Universe is uniform in structure and that all points are similar. Thus the Universe might appear isotropic from any particular galaxy in which man happened to be living...The mathematical transformation is easily carried out and leads to the conclusion that in the average the Universe would appear the same when seen from other galaxies. This is consistent with the assumption that the

³¹² *On the Shoulders of Giants*, ed., Stephen Hawking, Running Press Book Publishers, Phila., PA, 2002, pp. xi-xii.

Universe is uniform and that man does not occupy a preferred central galaxy.³¹³

Notice that in the last sentence Dicke bases his alternative explanation on the “assumption...that man does not occupy a preferred central galaxy,” not on any hard evidence at his disposal. The only thing he possesses that can give pause to examine his “alternative” is that he can produce a “mathematical transformation” that will make it a possibility. As we will see many times in this discourse, the pliable world of mathematics comes to the rescue for those who are looking for an escape from the observational evidence that places Earth in the center of the universe. Mathematically speaking, one could make Jupiter the center of the solar system and the universe, or Venus or Mars or Proxima Centauri, and have everything meet the mathematical specifications. Newtonian relativity, because it holds that everything is in motion, allows for any object to serve as the center insofar as the physical motions are involved.³¹⁴

In addition, Dicke’s physical explanation is certainly not convincing. He states: “Not only is the distribution uniform but the above described motions with respect to us represent a uniform dilation.” Analogously, place yourself in the middle of a merry-go-round. You will observe all the horses equidistant from your central location. Now

³¹³ Robert H. Dicke, *Gravitation and the Universe*, Jayne Lectures for 1969, American Philosophical Society, Philadelphia, 1970, p. 55. Later, Dicke continues to puzzle over galaxy distribution: “There are peculiar puzzles about this Universe of ours. As it gets older, more and more of the Universe comes into view, but when new matter appears it is isotropically [evenly] distributed about us, and it has the appropriate density and velocity to be part of a uniform Universe. How did this uniformity come about if the first communication of the various parts of the Universe with each other first occurred long after the start of the expansion?...The puzzle here is the following: how did the initial explosion [the Big Bang] become started with such precision, the outward radial motion became so finely adjusted as to enable the various parts of the Universe to fly apart while continuously slowing in the rate of expansion. There seems to be no fundamental theoretical reason for such a fine balance” (*ibid.*, pp. 61-62). We, of course, would answer that the galaxies appear as they are because they were created in that state, since it is quite apparent that science has no explanation how they could have evolved to their present state. Later Dicke admits that his Big Bang hypothesis could be “completely wrong” since “the observational basis for the analysis is meager” (*ibid.*, p. 72).

³¹⁴ As Fred Hoyle reminds us: “Let it be understood at the outset that it makes no difference, from the point of view of describing planetary motion, whether we take the Earth or the Sun as the center of the solar system. Since the issue is one of relative motion only, there are infinitely many exactly equivalent descriptions referred to different centers – in principle any point will do, the Moon, Jupiter...So the passions loosed on the world by the publication of Copernicus’ book, *De revolutionibus orbium caelestium libri VI*, were logically irrelevant...” (*Nicolaus Copernicus*, New York: Harper and Row, 1973, p. 1). Once, however, there is an immobile object in the mix, then there can only be one mechanical and mathematical center.

imagine the horses expanding outward away from you, at the same speed, in concentric circles. It is precisely this pattern and distribution that Dicke sees in his telescope when he looks at the galaxies. But now, place yourself on the outer rim of the merry-go-round. Since you are no longer in the center, you will be expanding away from the center with the horses. Will you see all the horses equidistant from you, and will they all be expanding away from you at the same speed? Obviously not. There is only one place, the center, in which equidistance and equal velocity can be satisfied together, and that is what Dicke's Earth-based telescope saw in its lens. The conclusion is inescapable but Dicke, not willing to accept the face-value evidence, desperately seeks for an alternative.

George F. R. Ellis

A few pages later, Hawking is again confronted with evidence that places Earth in the center of the universe. In the early 1960s a group of astronomers known as the Cambridge group, led by Martin Ryle, examined sources of radio waves from outer space. They found a variety of intensities. Their results led Hawking to conclude: "This could mean that we are at the center of a great region in the universe in which the sources are fewer than elsewhere." Of course, as he did with the previous evidence, Hawking gives himself an "alternative" to the data, stating: "Alternatively, it could mean that the sources were more numerous in the past, at the time that the radio waves left on their journey to us, than they are now."³¹⁵

That these kinds of decisions are based on Hawking's ideology is confirmed in his book *The Large Scale Structure of Space-Time*, in which he and co-author George Ellis admit the driving force leading to their conclusions. They write:

However we are not able to make cosmological models without some admixture of ideology. In the earliest cosmologies, man placed himself in a commanding position at the center of the universe. Since the time of Copernicus we have been steadily demoted to a medium sized planet going round a medium sized star on the outer edge of a fairly average galaxy, which is itself simply one of a local group of galaxies. Indeed we are now so democratic that we would not claim that our position in space is specially distinguished in any way. We shall, following Bondi (1960), call this assumption the Copernican principle.³¹⁶

³¹⁵ *A Brief History of Time*, Bantam Books, New York, 1988, p. 47.

³¹⁶ Hawking, S. W. And Ellis, G. F. R., *The Large Scale Structure of Space-Time*, Cambridge University Press, Cambridge, 1973, p. 134. Bondi, Hermann, *Cosmology*, Cambridge University Press, Cambridge, 1960. Bondi is very important to Hawking since, as we will see later, Bondi was the first to realize the implications of the Stefan-Boltzmann law concerning radiation emission, which, in turn, denied the possibility of an infinite universe, since radiation would also be infinite. Bondi's model, which held

Downright fearful of geocentrism and desiring to keep the *status quo*, Ellis stated in 1979: “Any weakening at all of the homogeneity principle implies a preferred position for our world – which is what the [cosmological] principle was designed to avoid.”³¹⁷ Hence, the “Copernican principle,” nowadays camouflaged by the term “cosmological principle,” is a driving force among today’s agnostic scientists. It is taken as an *a-priori* truth to which the rest of cosmology must conform. All evidence must be interpreted in light of this principle. As one author put it:

The concept that underlies much of modern cosmology is called the Copernican principle. Its origins can be traced to the assertion made in 1543 by Nicolaus Copernicus that the Earth is not the center of the universe. The modern, extended form of the principle was not stated explicitly, however, until 1948 by Hermann Bondi of the University of Cambridge....A generalization of the Copernican principle has come to be known as the cosmological principle. It states that not only is the position of the solar system without privileged status but furthermore no position anywhere in the universe is privileged.³¹⁸

There may be no privileged observers. Cosmology was not to repeat the pre-Copernican mistake of placing humans in the center of things....The large scale look of things from every point in the cosmos must in general resemble ours, that in any plausible model of the cosmos our perspective must be assumed ordinary.³¹⁹

Two decades later, the same George Ellis, while allowing for at least the possibility of an Earth-centered cosmology, reinforced the fact that one’s philosophical persuasion plays the major role in deciding between the two. In an interview with *Scientific American* he states:

that energy creates matter, was proposed in 1960 to satisfy the Stefan-Boltzmann law, and became known as the “steady-state” theory. By the same token, however, Bondi denied that there is no privileged position in the universe (i.e., there is no center which is distinguished from other points in the universe).

³¹⁷ George Ellis, “The Homogeneity of the Universe,” paper submitted to Gravity Research Foundation, March 1979, p. 2.

³¹⁸ George Gale, “The Anthropic Principle,” *Scientific American*, vol. 245, December 1981, p. 154.

³¹⁹ Timothy Ferris, *The Red Limit: The Search for the Edge of the Universe*, New York, Quill, 1983, p. 160.

People need to be aware that there is a range of models that could explain the observations. For instance, I can construct [for] you a spherically symmetrical universe with Earth at its center, and you cannot disprove it based on observations. You can only exclude it on philosophical grounds. In my view there is absolutely nothing wrong in that. What I want to bring into the open is the fact that we are using philosophical criteria in choosing our models. A lot of cosmology tries to hide that.³²⁰

In a 1995 paper, however, Ellis seems to have been sufficiently dismayed by the confusion caused by General Relativity's allowance of alternate cosmologies that he suggested physicists "should reconsider and perhaps refine the dogma of General Covariance." In brief, Ellis argues:

The essential point is that while all coordinate systems are mathematically allowed, most of them are far too wiggly and unruly to be of any physical interest; for purposes of application, it makes sense, and indeed is desirable, to restrict coordinates to those that are suitably 'smooth' from a physical and geometric viewpoint....there is a preferred rest frame and time coordinate in standard cosmology, and using any other coordinates simply obscures what is happening. The Cosmic Microwave Background Radiation determines the preferred rest frame (and associated time coordinate) to high accuracy....The subject is completely opaque if other, ill-adapted coordinates are used.³²¹

Here we see that Relativity's builders cannot live comfortably in the house they have framed, and thus they seek to alleviate the difficulty by taking a page from geocentric cosmology, only in Ellis' universe the Earth is not allowed to be the "preferred rest frame" for reasons he does not reveal, and thus the CMB becomes his crutch of choice. But it makes little difference upon which crutch Ellis props himself, despite the fact that he picks a rest frame that is, ironically, moving at the speed of light. He has shown us once again that Relativity is a contradiction in terms. Pure Relativity won't allow "rest frames," and if Ellis insists upon creating them, he merely exposes Relativity's inherent weakness, that is, its mathematics tells us nothing about physical reality.

Still, although Ellis made at least some concessions based on "philosophical grounds," Stephen Hawking, with the whisk of his ideological wand, turned the "Copernican Dilemma" into the "Copernican Principle." It is obvious that he has no intentions of viewing

³²⁰ "Profile: George F. R. Ellis," W. Wayt Gibbs, *Scientific American*, October 1995, Vol. 273, No. 4, p. 55.

³²¹ G. F. R. Ellis and D. R. Matravers, "General Covariance in General Relativity?" in *General Relativity and Gravitation*, Vol. 27, No. 7, 1995, pp. 778, 781.

the cosmos as an Earth-centered universe, despite the lack of scientific evidence for his own view. A special place for Earth is as distasteful to him as it was an “intolerable horror” to Edwin Hubble. Going a step beyond Hubble, Hawking tries to promote his view by making it sound as if, of the two cosmologies, his is the more “modest,” and thus the more legitimate. With all that we know about Hawking’s philosophy, it is not difficult to see past this smoke screen. He is merely using the cosmos as a mirror to reflect his own agnosticism. In the end, Hawking’s “Copernican principle” is based on false modesty, for although he gives the impression that his choice is from humility, in reality, it is based on a desire to escape from having to submit himself to a divine being who, his own evidence shows, placed Earth at the center of the universe.³²²

Although we must at least give credit to Hawking for admitting that recent cosmological evidence shows Earth as the center of the universe, it becomes obvious that he has admitted this information only to deny it later, with the sole purpose to educate people to his personal opinion that the Earth is nothing but a speck of dust whirling around in a cold and impersonal universe. His bias is confirmed by the fact that, although his 1988 book *A Brief History of Time* makes a painstaking effort to list and explain all the notable scientists and their discoveries leading to modern science’s present views of cosmology, Hawking makes absolutely no effort at listing the scientists who have given extensive astronomical evidence of an Earth-centered universe, even though he admitted such evidence existed. This is rather surprising since Hawking admits to the vicissitudes of current cosmological studies in his book, namely, that his theories have led him away from the concept of the Big Bang as an explanation for the origin of the universe.

Carl Sagan

Following suit, [Carl Sagan](#), who wrote the *Foreword* to Hawking’s best-seller, *A Brief History of Time*, engages in the same false humility which, in reality, is a clever attempt to rid himself of having any

³²² Although he denies being an atheist, he does admit to being an agnostic. He writes: “These laws [physical laws] may have originally been decreed by God, but it appears that he has since left the universe to evolve according to them and does not now intervene in it” (*A Brief History of Time*, p. 122). As noted previously, however, according to one biography, Hawking and his wife, Jane, separated based in part because she, as a devout Christian, could not tolerate his atheism any longer (as cited by John Horgan’s *The End of Science*, pp. 94-95, from Michael White’s and John Gribbon’s, *Stephen Hawking: A Life in Science*, (Penguin Books, 1993). It is certainly surprising that Hawking is permitted to hold a seat on the Pontifical Academy of Science in Rome. The Academy, which houses 80 members, nominates those whom it desires, but the Vatican must approve all nominees. In 1975, Hawking received the “Pius XII medal” from Pope Paul VI as “a Young Scientist for distinguished work.” In 1986, Hawking met with the Pope again, where he was admitted to the Pontifical Academy of Science.

responsibility to a supreme Creator or the redemption He offers. In his book, *Pale Blue Dot*, these precise sentiments are summed up very concisely in the following sentences:

The Earth is a very small stage in a vast cosmic arena...Our posturings, our imagined self-importance, the delusion that we have some privileged position in the Universe, are challenged by this point of pale light. Our planet is a lonely speck in the great enveloping cosmic dark. In our obscurity, in all this vastness, there I see no hint that help will come from elsewhere to save us from ourselves.³²³

Or, from an even more popular venue:

As long as there have been humans we have searched for our place in the cosmos. Where are we? Who are we? We find that we live on an insignificant planet of a humdrum star lost in a galaxy tucked away in some forgotten corner of a universe in which there are far more galaxies than people.³²⁴

To Sagan, “we are, all of us, descended from a single and common instance of the origin of life in the early history of our planet.”³²⁵ We are “only custodians for a moment of a world that is itself no more than a mote of dust in a universe incomprehensively vast and old.”³²⁶ He concludes: “neither we nor our planet enjoys a privileged position in nature.”³²⁷

J. Richard Gott

This glum picture of Earth as a lost child in a thick forest of galaxies is the preference of almost all scientists today. Whenever the opportunity arises, they brainwash the public into believing it. Another is astrophysicist J. Richard Gott III from Princeton University. Gott more or less admits that Copernicanism and Darwinism are the two pillars that hold up agnostic science today. Mimicking the wording and cadence of Sagan, he writes:

³²³ *Pale Blue Dot: A Vision of the Human Future in Space*, New York, Ballantine Books, 1977, p. 9.

³²⁴ “A Gift for Vividness,” Carl Sagan, *Time Magazine*, Oct. 20, 1980, p. 61.

³²⁵ Carl Sagan, *Cosmos*, New York, Random House, 1980, p. 38.

³²⁶ Carl Sagan, *Comet*, New York, Random House, 1985, p. 367.

³²⁷ Carl Sagan, *Cosmos*, p. 190.

The Copernican revolution taught us that it was a mistake to assume, without sufficient reason, that we occupy a privileged position in the universe. Darwin showed that, in terms of origin, we are not privileged above other species. Our position around an ordinary star in an ordinary galaxy in an ordinary supercluster continues to look less and less special. The idea that we are not located in a special spatial location has been crucial in cosmology....In astronomy the Copernican principle works because, of all the places for intelligent observers to be, there are by definition only a few special places and many nonspecial places, so you are likely to be in a nonspecial place.³²⁸

We see that Copernicanism has developed into far more than identifying the one particular celestial body that revolves around another celestial body. Copernicanism is nothing less than the foundation for modern man's view of himself: a lonely being who, by time and chance, is placed on a remote island in space with no more thought about his reason for existence and ultimate destiny than the stars from which he thinks he evolved. Rather than taking joy in the fact that God made man in his own image and placed him at the center of his creation, today's atheists and agnostics seek to remove man to the remote parts of the universe and place him on the same level as star dust. Copernicus has, indeed, turned the world upside down, both literally and figuratively. Fortunately, as we shall see, the same science that was used to promote Copernicus now seeks to dethrone him, and it is only a matter of time until that happens.

³²⁸ J. Richard Gott III, "Implications of the Copernican Principle for our Future Prospects," *Nature*, May 27, 1993, vol. 363, p. 315. The ellipse contains: "...leading directly to the homogeneous and isotropic Friedmann cosmological models in general relativity theory which have been remarkably successful in predicting the existence and spectrum of the cosmic microwave background radiation." In his five-page article Gott goes into a long pedantic calculation of how long the human species will last. Remarking on Brandon Carter's introduction of the idea in 1983, Gott writes: "Interestingly, Carter's argument depends implicitly on the idea presented formally here: that according to the Copernican principle, among all intelligent observers (including those not yet born) you should not be special....Let us formalize this as the 'Copernican anthropic principle' (*ibid.*, p. 316).

Gamma-Ray Bursts and “The Copernican Dilemma”

The most significant scientific evidence that is challenging Copernican cosmology hails from that gathered by astronomers themselves. In short, they are increasingly confronted with evidence that places Earth in the center of the universe. For example, in the recently published book by Oxford University Press titled *The Biggest Bangs: The Mystery of Gamma-Ray Bursts, the Most Violent Explosions in the Universe*, author and astrophysicist Jonathan I. Katz of Washington University, a scientist who admits of no partiality toward a geocentric universe, includes a chapter titled *The Copernican Dilemma*. This title clearly indicates he has found disturbing evidence that puts the Copernican theory in question. Katz’s studies have found that, when all the known gamma-ray bursts are calculated and catalogued, they show Earth to be in the center of it all. He writes:

The uniform distribution of burst arrival directions tells us that the distribution of gamma-ray-burst sources in space is a sphere or spherical shell, with us at the center (some other extremely contrived and implausible distributions are also possible). But Copernicus taught us that we are not in a special preferred position in the universe; Earth is not at the center of the solar system, the Sun is not at the center of the galaxy, and so forth. There is no reason to believe we are at the center of the distribution of gamma-ray bursts. If our instruments are sensitive enough to detect bursts at the edge of the spatial distribution, then they should not be isotropic on the sky, contrary to observation; if our instruments are less sensitive, then the $N \propto S^{-3/2}$ law should hold, also contrary to observation. That is the Copernican dilemma.³²⁹

Notice the clear geocentric language the author uses, that is, he sees in his telescope a sphere or spherical shell with us at the center.³³⁰

³²⁹ Jonathan Katz, *The Biggest Bangs: The Mystery of Gamma-Ray Bursts, The Most Violent Explosions in the Universe*, Oxford University Press, 2002, pp. 90-91.

³³⁰ Although *Galileo Was Wrong* will often refer to Earth as the center of the universe, this geocentric view is distinct from other views which hold that the Milky Way galaxy, not Earth, is the center of the universe, a view espoused, for example, by astrophysicist D. Russell Humphreys in “Our galaxy is the center of the universe, quantized-redshifts show,” *Technical Journal* 16 (2): 95-104; and *Starlight and Time*, Green Forest, AR: Master Books, 1994. Another such advocate is Robert V. Gentry in “Creation’s Tiny Mystery,” 3rd edition, *Earth Science Associates*, Knoxville, TN, pp. 287-290, 1992; and *Modern Physics Letters A* 12 (37): 2919-2925, 1997. Both Humphreys and Gentry posit that the Earth has diurnal and translational motion (i.e., that the Earth both spins on an axis and revolves around the sun). Another geocentric view is that of Catholic Fernand Crombette (1880-1970). He held that the Earth, although centrally located in the universe, rotates on an axis each 24-hours. These views will be critiqued in volume II of this series. Suffice it to say for now that the geocentric view espoused in *Galileo Was Wrong* is actually a geostatic view, and follows the Papal and Sacred Congregation

“Isotropic” means that the gamma-ray bursts are the same in all directions from Earth.³³¹ Katz knows the implications of his discovery since he immediately makes reference to the contradictions his findings have against the Copernican theory. Since Katz, being a modern astrophysicist, is a believer in the Big Bang theory and considers Earth as a speck of dust on one of the outer rims of the universe, we see him struggling to free himself from the implications of his evidence as he writes: “There is no reason to believe we are at the center of the distribution of gamma-ray bursts,” but he then admits twice that such a position would be contrary to observation. In other words, he can’t believe his own eyes since obviously he has been so conditioned to see just the opposite. Katz continues:

To this day, after the detection of several thousand bursts, and despite earnest efforts to show the contrary, no deviation from a uniform random distribution (isotropy) in the directions of gamma-ray bursts on the sky has ever been convincingly demonstrated.³³²

decrees of 1616, 1633 and 1664, which declare that Earth possess neither diurnal or translational motion, and is, in fact, motionless in the center of the universe.

³³¹ Here it is necessary to distinguish between *isotropic* and *homogeneous*. *Isotropic* refers to an environment that looks the same in all directions, excluding the observer’s location. For example, if an observer is perched on top of a symmetrical sand hill in the middle of a flat desert, as he looks around the whole circumference of his view, he sees the same grade of hill approaching him, as well as a vast flat desert in all directions. *Homogeneous* refers to an environment that appears the same in all locations, but also includes the observer’s location. In this case, the observer is not seated on a sand hill but on the flat desert itself, and as he looks out he sees a flat desert in all directions, including his seated position. Current cosmology, either Big Bang or Steady-State (non Earth-centered cosmologies) holds, with few exceptions, that the universe is both isotropic and homogeneous. As Edwin Hubble described it: “There must be no favoured location in the universe, no center, no boundary; all must see the universe alike. And, in order to ensure this situation, the cosmologist postulates spatial isotropy and spatial homogeneity, which is his way of stating that the universe must be pretty much alike everywhere and in all directions” (*The Observational Approach to Cosmology*, p. 54). If the universe is isotropic but inhomogeneous, it allows for an Earth-centered cosmology, since only from an isotropic center will make the universe appear the same in all directions, but appear different when not observed from the center.

³³² Jonathan Katz, *The Biggest Bangs: The Mystery of Gamma-Ray Bursts, The Most Violent Explosions in the Universe*, Oxford University Press, 2002, p. 84. A recent article in *Sky and Telescope* supported this interpretation: “There’s this myth that gamma-ray bursts are chaotic and unpredictable...but that’s not true.’ In fact GRB’s might even be used as ‘standard candles’ with which to measure cosmic distances” (Joshua Roth, “Gamma-Ray Bursts Next Door,” *Sky and Telescope*, January 9, 2002). Gamma-ray bursts are equivalent to 10^{45} watts of energy, which is over a million trillion times as powerful as the sun. The bursts occur at the rate of about one per day, but they are fast-fading and random, never occurring in the same place twice.

As Katz goes on to explain, the “Copernican dilemma” for astronomers is that they are required to explain why there are no faint gamma-ray bursts, since, according to the Big Bang theory, the universe is old and expansive. If so, then more distant bursts should register more faintly when compared to closer bursts. One theory proposes that the Milky Way is surrounded by a halo of Dark Matter that emits gamma-rays, but this is pure speculation. No one has proven that Dark Matter actually exists, let alone produces gamma rays. A second theory holds that gamma-ray bursts originated from distances of ten billion light years, near the edge of the observable universe, and thus would be uniformly distributed as the rays approached Earth. But this would require the gamma-ray sources to have incredible energy in order to last long enough to reach Earth. Another problem was that a super burst appeared in the Large Magellanic Cloud in 1979, a satellite of the Milky Way and thus very close to Earth. Not surprisingly, the “large distance” theory was discarded as well.

After citing some experiments designed to answer the Copernican dilemma,³³³ the author admits:

No longer could astronomers hope that the Copernican dilemma would disappear with improved data. The data were in hand, and their implication inescapable: we are at the center of a spherically symmetric distribution of gamma-ray-burst sources, and this distribution has an outer edge. Beyond this edge the density of burst sources decreases to insignificance.³³⁴

The implications of this admission are quite significant. Having no worthy explanation for the isotropic distribution of gamma-ray bursts, the astrophysicist is forced to admit one of the major planks of geocentric cosmology – that Earth is at the center of the forces we see in the universe. Interestingly enough, Katz had opened the chapter reminding the reader that

Mikolay Kopernik, the Polish astronomer also known by his Latin name Nicolaus Copernicus, established that Earth and the planets revolve around the Sun. The importance of Copernicus’s ideas was both philosophical and scientific: Man is not at the center of the universe, but is only an insignificant spectator, viewing its fireworks from somewhere in the bleachers....In modern times this has been elevated into the

³³³ In particular, the BATSE (Burst and Transient Source Experiment) launched in 1991, but again, “the deficiency of faint bursts, compared to the expected $-3/2$ power law, is unquestionable (p. 109)...Through its 9-year life BATSE detected nearly 3000 bursts, and only reconfirmed these conclusions with ever-increasing accuracy” (p. 111).

³³⁴ Jonathan Katz, *The Biggest Bangs: The Mystery of Gamma-Ray Bursts, The Most Violent Explosions in the Universe*, Oxford University Press, 2002, p. 111.

cosmological principle, which states that, if averaged over a sufficiently large region, the properties of the universe are the same everywhere; our neighborhood is completely ordinary and unremarkable. We are not special, and our home is not special, either. This is one of the foundations of nearly all modern cosmologies.³³⁵

Thus we see that Katz himself sees the implications of his own studies. He knows that gamma-ray bursts demolish the cosmological principle. Perhaps man is at the center of the universe; perhaps he is special and not merely an insignificant spectator but, in fact, is at the hub of all that goes on around him. If that is the case, we wonder if Katz, since he, too, is a man made in the image of God, wondered, even for a few fleeting minutes, whether these gamma-ray bursts meant that Earth was not a product of time and chance but, indeed, was placed in a very special and significant place by its Creator. We wonder if Katz would ever consider, since gamma-rays are high energy photons,³³⁶ and photons are nothing but packages of light, that gamma-rays are one of the remnants of the first day of creation in which God, after having already created the heaven and the Earth (Genesis 1:1-2) said, ‘Let there be light’ (Genesis 1:3), thus distributing light uniformly around the already existing Earth?

Would he ever consider that God, knowing that man would be intensely curious about where he is positioned in the universe in relation to everything else, left sign posts all throughout the starry skies saying: “Here, O man, is the clue to your origin and your destiny.” Since Katz does not mention God or Genesis in his book, we will never know where his private thoughts led him, but it is almost a certainty that the very foundations of his life were shaken when he discovered that Earth was at the center point of photon disbursement.

Before he lowers the boom of gamma-ray evidence on unsuspecting Copernicans, Katz tries to offer some solace by appealing to the cosmological principle, which is, he says, supported by studies of the cosmic microwave background radiation (CMB), the popularized relic of the so-called “Big Bang.”³³⁷ But we wonder how Katz can be so

³³⁵ Jonathan Katz, *The Biggest Bangs: The Mystery of Gamma-Ray Bursts, The Most Violent Explosions in the Universe*, Oxford University Press, 2002, p. 82.

³³⁶ According to Katz’s glossary, a Gamma ray is “an electromagnetic radiation whose photons have energies greater than about 100,000 eV. Sometimes lower-energy photons (often as low as 10,000 eV) are also called gamma rays, overlapping the definition of X rays...”

³³⁷ Katz says it is so called because “distances of billions of light-years are called cosmological, because they include the entire universe, and light from these remote regions takes so long to reach us that it was emitted when the universe was significantly younger than it is now and had different properties” (p. 24). What the different properties are Katz does not tell us.

confident of his interpretation of the CMB's isotropy when he reveals just a few paragraphs later that gamma-ray bursts have the same isotropy. For the isotropy of the former, Katz believes he has an ally in the cosmological principle and Copernican theory, but the isotropy of the latter, he admits, speaks against both. Why the contradiction? Because Katz is, without proof, taking for granted the main tenet of the cosmological principle, that is, that a Big Bang occurred 13.5 billion years ago. In such a universe, Katz believes he can explain the CMB's isotropy as the result of its being evenly distributed throughout the whole universe, as opposed to gamma-ray bursts that, Katz realizes, have isotropic distribution only to a certain point, and then they suddenly disappear altogether. But how does Katz know that the isotropy of the CMB is situated any differently than the isotropy of the gamma-ray bursts? He doesn't, and neither does he know the origination of the 2.728° Kelvin CMB radiation. The only thing he knows is that the CMB is found in isotropic distribution around the Earth, the same as gamma-ray bursts. If the Big Bang were not influencing him, the CMB isotropy should have led Katz to the same conclusion to which he arrived for gamma-ray bursts – that Earth is in the center of it all.

Sometimes, however, the correct conclusions do seep through the dam. Joseph Silk of the University of California (Berkeley) says what Katz is afraid to admit:

Studies of the cosmic background radiation have confirmed the isotropy of the radiation, or its complete uniformity in all directions. If the universe possesses a center, we must be very close to it...otherwise, excessive observable anisotropy in the radiation intensity would be produced, and we would detect more radiation from one direction than from the opposite direction.³³⁸

In other words, the isotropy of the CMB can only be true from an Earth-centered location. If observed anywhere else in the universe the CMB will appear anisotropic. Hence, because of the CMB's geocentric fingerprints, there have been various attempts to dismiss its isotropy. This is accomplished by presuming that, in addition to its isotropy, the universe is also homogeneous, since all Big Bang and Steady-State cosmologies require both isotropy and homogeneity. For example, we noted earlier that Stephen Hawking readily admitted his reluctance to entertain a non-homogeneous universe for fear of its "Earth-centered" implications. His co-author in the 1973 book *The Large Scale Structure of Spacetime*, George F. R. Ellis, admits the same:

³³⁸ Joseph Silk, *The Big Bang: The Creation and Evolution of the Universe*, San Francisco, W. H. Freeman and Company, 1980, p. 53.

Models of the sort described here have not been considered previously because of the assumption – made at the very beginning in setting up the standard models – of a principle of uniformity [homogeneity]...This is assumed for *a priori* reasons and not tested by observations. However, it is precisely this principle that we wish to call into question. The static inhomogeneous model discussed in this paper shows that the usual unambiguous deduction that the universe is expanding is a consequence of an unverified assumption, namely, the uniformity [homogeneity] assumption. *This assumption is made because it is believed to be unreasonable that we should be near the center of the Universe.*³³⁹

As we noted previously, Ellis had once shaken the halls of modern science with what other scientists said was “an earthquake that made Copernicus turn in his grave.” In a lengthy article in *New Scientist* in 1978, Ellis’ own General Relativity theory forced him to conclude that our galaxy is located near one of “two centers” in the universe that are in an antipodal relation.³⁴⁰ Although Ellis allows that his observations and calculations may be the result of a wrong interpretation, no one has since discovered any such errors, including Ellis. In fact, the then editor of *Nature*, Paul C. W. Davies, admitted that Ellis’ theory did not contain any logical errors and that in every aspect seems to be in agreement with observed facts. Under the article title “Cosmic Heresy,” he writes:

Often the simplest of observations will have the most profound consequences. It has long been a cornerstone of modern science, to say nothing of man’s cosmic outlook, that the Earth attends a modest star that shines in an undistinguished part of a run-of-the-mill galaxy. Life arose spontaneously and man evolved on this miscellaneous clump of matter and now directs his own destiny without outside help. This cosmic model is supported by the Big-Bang and Expanding Universe concepts, which in turn are buttressed by the simple observation that astronomers see redshifts wherever they look.

These redshifts are due, of course, to matter flying away from us under the impetus of the Big Bang. But redshifts can also arise from the gravitational attraction of mass. If the Earth were

³³⁹ G. F. R. Ellis, “Is the Universe Expanding?” *General Relativity and Gravitation*, vol. 9, no. 2, 1978, p. 92, emphasis added. Ellis proceeds to argue: “...where would one be likely to find life like that we know on Earth? The answer must be, where conditions are favorable for life of this kind; but in the model we are considering, the conditions for life would be most favorable near the center, where the universe is cool.” See also: G. F. R. Ellis, R. Maartens and S. Nel, “Is the Universe Expanding – But Maybe We’re Near Its Center?” *Monthly Notices of the Royal Astronomical Society*, 154:187-195, 1978.

³⁴⁰ *New Scientist*, May 25, 1978, p. 507.

at the center of the universe, the attraction of the surrounding mass of stars would also produce redshifts wherever we looked! The argument advanced by George Ellis in this article is more complex than this, but his basic thrust is to put man back into a favored position in the cosmos. His new theory seems quite consistent with our astronomical observations, *even though it clashes with the thought that we are godless and making it on our own.*³⁴¹

Davies ends his evaluation with the leading question: “Is the Copernican revolution maybe out of date?” A reporter registered the same sentiments for the *Vancouver Sun*:

Copernicus must be orbiting in his grave. Five hundred years after he laid to rest the idea that Man is the center of the universe, another cosmologist is seriously suggesting that the center of the universe is exactly where we are....No heresy now, the Copernican view is dogma. And it is a dogma that University of Capetown mathematician George Ellis is questioning....The idea is a modern heresy. It violates a principle of Cosmic Democracy that says that our corner of the universe is no different from any other....Ellis proposes that it is all an illusion.³⁴²

The geocentric implications of the cosmological evidence are not merely a blip on the radar screen. Whole symposiums have been dedicated to answering the mounting evidence. In September 1973, Cracow, Poland, hosted “Copernicus Symposium II,” sponsored by the International Astronomical Union. One of the addresses at the symposium was titled: “Confrontation of Cosmological Theories with Observational Data” denoting, of course, that current findings in cosmology are showing mounting evidence of a non-Copernican universe.³⁴³

Similarly, in a paper titled: “Geocentrism Re-Examined,” the authors admit:

Observations show that the universe is nearly isotropic on very large scales. It is much more difficult to show that the universe is radially homogeneous....This is usually taken as an axiom, since otherwise we would occupy a special position.³⁴⁴

³⁴¹ P. C. W. Davies, “Cosmic Heresy?” *Nature*, 273:336, 1978, emphasis added.

³⁴² Reporter Tim Padmore, “A Great Theory Once – Now It’s Been Recycled,” *Vancouver Sun*, Vancouver, Canada, October 2, 1973.

³⁴³ M. S. Longair, editor, Dordrecht, Holland and Boston, D. Reidel Publishing Co., 1974. See especially Brandon Carter’s, “Large Number Coincidences and the Anthropic Principle,” pp. 291-298, in Longair’s work.

By “special position,” of course, he means Earth in the center of the universe. In order to avoid putting Earth at these privileged coordinates, the author tells us that modern cosmologists have presumed the universe is “homogeneous” but no one has proven it to be so, and the author will thus “...consider several empirical arguments for radial homogeneity, all of them based on the cosmic microwave background (CMB).” His conclusion for homogeneity is less than stellar as he admits, after 10 pages of calculus, that “...the bookkeeping is not yet accurate enough to yield a 10% limit on the radial homogeneity of the CMB temperature.”³⁴⁵

In 1973, Misner, Thorne and Wheeler had already revealed that the CMB had the precise form and intensity expected if Earth were the centerpiece of a blackbody cavity. They write:

“The expansion of the universe has redshifted the temperature of the freely propagating photons in accordance with the equation $T \propto 1/a$. As a consequence, today they have a black-body spectrum with a temperature of 2.7 K....Because it is initially in thermal equilibrium with matter, this primordial radiation initially has a Planck black-body spectrum...that radiation with a Planck spectrum as viewed by one observer has a Planck spectrum as viewed by all observers...”³⁴⁶

As Katz failed to do, these authors did not follow their discovery to its logical conclusion, namely, that there is a high likelihood that Earth *is in the center* of this blackbody radiation, and the universe is closed.

³⁴⁴ Jeremy Goodman, “Geocentrism Re-examined,” Princeton University Observatory, Peyton Hall, Princeton, NJ, June 9, 1995, p. 1. Goodman adds: “...the isotropy of the universe on large scales *is* well established. Results from the Cosmic Background Explorer Satellite (COBE) show that the temperature of the microwave background (CMB) deviates slightly from isotropy, but only at the level $(\Delta T/T)_{\text{rms}} \approx 1.1 \times 10^{-5}$ on angular scales $\geq 10^\circ$, apart from a dipole pattern that is conventionally attributed to the peculiar velocity of the Sun and the Galaxy” (*ibid.*, p. 2)....There may exist ‘standard candles’ at $z \ll 1$, such as Type I supernovae. Among homogeneous Friedmann models, unfortunately, the shape of the magnitude-redshift relation for standard candles already depends on two parameters: the density parameter, Ω , and the cosmological constant, Λ . Only superb data will permit one to fit for a third parameter and thereby constrain the homogeneity of the universe on the scale of the present horizon.” In other words, there is simply no room for the “homogeneous” universe desired by the Big Bang Copernicans.

³⁴⁵ *Ibid.*, p. 11.

³⁴⁶ Charles W. Misner, Kip S. Thorne and John A. Wheeler, *Gravitation*, W. H. Freeman and Co., 1973, pp. 766, 779, and in general pages 764-797.

Others have interpreted the slight anisotropy of the CMB as indicating it is Euclidean (i.e. has dimensions), thus allowing a center.³⁴⁷

Those who have not yet been enlightened to the idea that Earth could be in the center have at least understood that the evenly spread and universally pervasive CMB could even serve as an absolute frame of reference. As V. J. Weisskopf states:

It is remarkable that we now are justified in talking about an absolute motion, and that we can measure it. The great dream of Michelson and Morley is realized... It makes sense to say that an observer is at rest in an absolute sense when the 3K radiation appears to have the same frequencies in all directions. Nature has provided an absolute frame of reference. The deeper significance of this concept is not yet clear.³⁴⁸

Going even deeper, Weisskopf ties the CMB evidence to the opening chapter of Genesis:

Indeed, the Judeo-Christian tradition describes the beginning of the world in a way that is surprisingly similar to the scientific model. Previously, it seemed scientifically unsound to have light created before the sun. The present scientific view does indeed assume the early universe to be filled with various kinds of radiation long before the sun was created. The Bible says about the beginning: “And God said, ‘Let there be light’; and there was light. And God saw the light, that it was good.”³⁴⁹

[Arno Penzias](#), attributed with [Robert Wilson](#) for finding and applying the Cosmic Microwave Background Radiation to the Big Bang theory,³⁵⁰ voiced a similar opinion to Weisskopf’s, stating:

³⁴⁷ Paolo de Bernardis, et al., “A flat universe from high-resolution maps of the cosmic microwave background radiation,” *Nature* 404, 955–959, 2000; and V. G. Gurzadyan and S. Torres, “Testing the effect of geodesic mixing with COBE data to reveal the curvature of the universe,” *Astronomy and Astrophysics*. 321:19–23, 1997, which abstract reads: “If the detected eccentricity of anisotropy spots can be attributed to the effect of mixing it implies the negative curvature of the Universe and a value of $\Omega < 1$.”

³⁴⁸ V. J. Weisskopf, *American Scientist*, 71, 5, 473 (1983). See also George Smoot and Keay Davidson, *Wrinkles in Time* (Avon Books, New York, 1993), p. 117; George Smoot, et al., *Physical Review Letters* 39: 898. 1979; *Astrophysical Journal*, 234: L83.

³⁴⁹ *Ibid.*

³⁵⁰ Arno A. Penzias and Robert W. Wilson, *Astrophysical Journal*, 142: 419-427 (1965).

The thing I'm most interested in now is whether the universe is open or closed. If it is open, and the data seems to indicate that it is open, this is precisely the universe that organized religion predicts, to put it in crude terms. A closed universe, one that explodes, expands, falls back on itself and explodes again, repeating the process over and over eternally, that would be a pointless universe...A theologian friend of mine who is a priest told me once he could not conceive of Calvary happening twice. He said his faith as a Christian would be shaken if it could be proven to him that the universe, with its finite number of particles, could be reconstituted an infinite number of times...In other words, a closed universe would be pointless as the throw of dice. But it seems to me that the data we have in hand right now clearly show that there is not nearly enough matter in the universe, not enough by a factor of three, for the universe to be able to fall back on itself ever again. *My argument is that the best data we have are exactly what I would have predicted, had I nothing to go on but the five books of Moses, the Psalms, the Bible as a whole.*³⁵¹

Another example is Bernard Haisch, editor of the prestigious *Astrophysical Journal*, who holds that the Casimir Effect reveals the existence of a “zero-point field,” that is, that space is not a vacuum but is filled with infinitesimally small particles (which we will examine in depth later), which he envisions as the scientific fulfillment of Genesis 1:3’s “Let there be light,” constituting “the background sea of light whose total energy is enormous.”³⁵²

On the one hand, it is admirable to see these famous scientists attempt to relate their cosmological discoveries to the opening chapters

³⁵¹ Interview by Malcolm W. Browne appearing in *The New York Times*, March 12, 1978, emphasis added. Penzias and Wilson won the Nobel Prize for their discovery of the CMB in 1978.

³⁵² Haisch’s proposal of the zero-point field in the Casimir Effect was considered worthy enough to be published by *Physical Review* (B. Haisch, A. Rueda, and H.E. Puthoff, *Physical Review A*, 49, 678, 1994). In an article in *Science and Spirit Magazine* titled “Brilliant Disguise: Light, Matter and the Zero-Point Field,” Haisch holds that the zero-point energy field results when, due to the Heisenberg *Uncertainty Principle* (which says that there will be continual random movement in electromagnetic waves), all the energy in the random movements are added up producing the “background sea of light whose total energy is enormous: the zero-point field. The ‘zero-point’ refers to the fact that even though this energy is huge, it is the lowest possible energy state.” Other articles include: “BEYOND $E=mc^2$: A First Glimpse of a Post-modern Physics in Which Mass, Inertia and Gravity Arise from Underlying Electromagnetic Processes,” B. Haisch, A. Rueda and H.E. Puthoff, *The Sciences*, November/December, Vol. 34, No. 6, pp. 26-31, 1994. B Haisch and A. Rueda, “Electromagnetic Zero-Point Field as Active Energy Source in the Intergalactic Medium,” presented at 35th Jet Propulsion Conference, June 1999. “Vacuum Zero-Point Field Pressure Instability in Astrophysical Plasmas and the Formation of Cosmic Voids,” A. Rueda, B. Haisch and D. C. Cole, *Astrophysical Journal*, 445, 7, 1995.

of Genesis. On the other hand, such efforts demonstrate science's biased presuppositions both in cosmology and in exegeting Genesis. What is either casually overlooked or purposely ignored in these overtures toward Genesis is that Moses' first words did not posit a great light exploding into existence; rather, he is very explicit about Earth's primal existence. Moses' description of the Earth as being a formless and unadorned mass shrouded in darkness with its surface covered by water is stated in Genesis 1:1-2 for the express purpose of indicating that the Earth existed *before* the light came into being. The light had a function, which was to dispel the darkness from the Earth, a simple cause-and-effect relationship. If Weisskopf, Penzias, Haisch or any other scientist wishes to crown his theory with divine favor, then he must adhere to the precise words that "the five books of Moses, the Psalms, the Bible as a whole" have given to us rather than foist their biased eisegesis on the biblical text. As it stands, Genesis 1, literally interpreted, is diametrically opposed to the Big Bang theory, since the latter holds that the Earth did not come into existence until some 8 billion years after the "light." Moreover, "...the Psalms *and* the Bible as a whole" do not speak of the CMB as the absolute reference point, since Scripture already granted that privileged position to the Earth (cf. 1Ch 16:30; Ps 96:10; Ec 1:5); and it was the firmament that was then expanded and made to rotate with the heavenly bodies around the Earth. Of course, if the above named scientists, because of this disagreement with Scripture, were to disown Moses as their ultimate guide and instead insist on the CMB as the absolute frame of reference, this should serve as the death-knell for Relativity theory (which claims there is nothing even resembling an absolute reference frame in space), but, conveniently, that implication was quietly suppressed in 1965 and was, shall we say, hushed up in polite society.³⁵³

Back to the "Copernican Dilemma." Katz is not the only one to conclude that the evidence shows Earth as the center of the universe. In 1995, G. J. Fishman and C. A. Meegan, after analyzing a number of gamma-ray bursts, came to the only logical conclusion: "The isotropy and inhomogeneity of the bursts show only that we are at the center of the apparent burst distribution."³⁵⁴ During the same time, S. E. Woolsey's review of gamma radiation stated the logical conclusion even more directly: "The observational data show conclusively that the Earth is situated at or very near the center of the gamma-ray burst universe."³⁵⁵

³⁵³ Attempts at depending on an anisotropy of the CMB are very tenuous at best. The accepted temperature of the CMB is 2.735. No variations in this temperature have been found above thirty millionths of a degree.

³⁵⁴ *Annual Reviews of Astronomy and Astrophysics* 33, 415, 1995.

³⁵⁵ "Gamma-Ray Bursts: What Are They?" in *Seventeenth Texas Symposium on Relativistic Astrophysics and Cosmology*, New York Academy of Sciences, New York, 1995, p. 446.

Interestingly enough, after gathering the data from the [Wilkinson Microwave Anisotropy Probe](#) (WMAP) of 2001, which analyzed the distribution of the CMB, Max Tegmark of the University of Pennsylvania, processed a computer image of his findings. Tegmark, even though he is an avowed Big Bang cosmologist, said something that probably even he didn't realize at the time. In remarking on the giant sphere the probe produced, he noted, "Our entire observable universe is inside this sphere of radius 13.3 billion light-years, *with us at the center*."³⁵⁶ Added to this was the interpretation of his wife, Angélica de Oliveira-Costa, who stated that the cosmic quadrupole and octopole are both very planar and aligned, which according to the CERN correspondent reporting the interview means that the points "happen to fall on a great circle on the sky," and we are in the center of that great circle.³⁵⁷ In their original paper, Tegmark and Oliveira-Costa noted that "the quadrupole...and the octopole have almost all their power perpendicular to a common axis in space, as if some process has suppressed large scale power in the direction of the axis."³⁵⁸ From a geocentric perspective, this evidence would naturally be understood as defining the axis upon which the universe rotates. Tegmark, *et al.*, allow such an interpretation, since they add:

How significant is this quadrupole-octopole alignment? As a simple definition of preferred axis [it] denotes the spherical harmonic coefficients of the map in a rotated coordinate system....if the CMB is an isotropic Gaussian random field, then a chance alignment this good requires a 1-in-62 fluke.³⁵⁹

³⁵⁶ (<http://www.hep.upenn.edu/max/wmap3.html>.) emphasis added.

³⁵⁷ A. de Oliveira-Costa, et al. 2004, *Physical Review D* 69 063516, as cited in Cern Courier, IOP Publishing, Inc, 2005. The CERN team also discovered that the finding "does not agree with the expectation from inflation" [Big Bang] and "casts doubts on the cosmological interpretation of the lowest- l multipoles...and...the claim that the first stars formed very early in the history of the universe." See also H. K. Eriksen, et al., *Astrophysical Journal* 605, 14, 2004.

³⁵⁸ Max Tegmark, Angélica de Oliveira-Costa and Andrew J. S. Hamilton, "A high resolution foreground cleaned CMB map from WMAP," *Physical Review D*, July 26, 2003, p. 13.

³⁵⁹ Max Tegmark, Angélica de Oliveira-Costa and Andrew J. S. Hamilton, "A high resolution foreground cleaned CMB map from WMAP," *Physical Review D*, July 26, 2003, p. 14. In light of Tegmark's axis, it should also be noted that evidence for the rotation of the universe was discovered in the early 1980s (Paul Birch, "Is the Universe Rotating?" *Nature*, vol. 298, 29 July 1982, pp 451-454; Mitchell M. Waldrop, "The Currents of Space," *Science*, vol. 232, April 4, 1986, p. 26). After examining 132 radio sources, Birch determined that the polarization angle translated into the universe rotating at a rate of 10^{-13} radians per year. Although this rotation has nothing to do with the daily rotation advocated in the geocentric model, the rotation coincides with Tegmark's findings of Earth being the center point of the universe. See also Yu

Perhaps just as important is the following remark by the Tegmark team:

What does this all mean?...it is difficult not to be intrigued by the similarities [of our findings] with what is expected in some non-standard [i.e., non Big Bang] models, for instance, ones involving a flat “small Universe” with a compact topology and one of the three dimensions being relatively small.³⁶⁰

This “non-standard...flat small Universe with compact topology,” and, as noted above, the one with the “preferred axis” with odds of “1-in-62 of being a fluke,” is precisely the one advocated by models of geocentric cosmology. In light of this startling data, perhaps Tegmark’s final comment is appropriate: “As so often in science when measurements are improved, WMAP has answered old questions and raised new ones.”³⁶¹ Or, as David Spergel stated in the same interview: “If the universe were finite, then this would rule out inflation and require something new.”³⁶² Although accurate, Spergel’s comment is quite an understatement. “Something new” means that all that has been taught about cosmology since the early part of the twentieth century, and perhaps going back as far as Isaac Newton’s infinite universe, is totally erroneous. In fact, Spergel and his colleagues have gone so far as to suggest that the small scale of the starry cosmos may be due to a “hall-of-mirrors” effect. Working alongside mathematician Jeffrey Weeks, *New Scientist* reports:

Scientists have announced tantalizing hints that the universe is actually relatively small, with a hall-of-mirrors illusion tricking us into thinking that space stretches on forever....Weeks and his colleagues, a team of astrophysicists in France, say the WMAP results suggest that the universe is not only small, but

Obukhov, “Gauge Theories of Fundamental Interactions,” 1990, Singapore, World Scientific.

³⁶⁰ Max Tegmark, Angélica de Oliveira-Costa and Andrew J. S. Hamilton, “A high resolution foreground cleaned CMB map from WMAP,” *Physical Review D*, July 26, 2003, p. 14.

³⁶¹ Max Tegmark, Angélica de Oliveira-Costa and Andrew J. S. Hamilton, “A high resolution foreground cleaned CMB map from WMAP,” *Physical Review D*, July 26, 2003, p. 14.

³⁶² Dennis Overbye, “Universe as Doughnut: New Data, New Debate,” *The New York Times*, March 11, 2003. Comments Overbye includes from other prominent scientists are: G. Hinshaw: “The fact that there appears to be an angular cutoff hints at a special distance scale in the universe”; George Smoot: “The basic idea is that God’s on a budget.”

that space wraps back on itself in a bizarre way (*Nature*, vol. 425, p. 593)...Effectively, the universe would be like a hall of mirrors, with the wraparound effect producing multiple images of everything inside.” Spergel adds: “If we could prove that the universe was finite and small, that would be Earth-shattering. It would really change our view of the universe”³⁶³

It is little wonder why Janna Levin, commenting on the WMAP data in the same interview, stated:

I suspect every last one of us would be flabbergasted if the universe was so small...I tried on the idea that we were really and truly seeing the finite extent of space and I was filled with dread. But I’m enjoying it too.³⁶⁴

Perhaps, as we noted earlier, Ms. Levin felt the same “dread” that Edwin Hubble and Stephen Hawking experienced when they realized their data were showing that the Earth was in the center of a small universe. Perhaps the equivocation between “dread” and “joy” is why Ms. Levin also wrote a paper seeking to downplay the inevitable geocentric interpretations of the WMAP data, but still finds herself having to admit the next best thing:

Copernicus realized that we are not at the center of the Universe. A universe made finite by topological identifications introduces a new Copernican consideration: while we may not be at the geometric centre of the Universe, some galaxy could be. A finite universe also picks out a preferred frame: the frame in which the universe is smallest. Although we are not likely to be at the centre of the Universe, we must live in the preferred frame (if we are at rest with respect to the cosmological expansion).³⁶⁵

Although many of the scientists who were asked to comment on the Tegmark analysis opined that a doughnut-shaped universe may be the best model to explain the new data, George Efstathiou of Cambridge

³⁶³ New Scientist, October 8, 2003.

³⁶⁴ Dennis Overbye, “Universe as Doughnut: New Data, New Debate,” *The New York Times*, March 11, 2003.

³⁶⁵ J. D. Barrow and J. Levin, “The Copernican principle in compact space–times,” *Monthly Notices of the Royal Astronomical Society*, December 2003, vol. 346, no. 2, pp. 615-618(4). Still working on the principle that the universe is both isotropic and homogeneous, Levin concludes her abstract with: “We show that the preferred topological frame must also be the comoving frame in a homogeneous and isotropic cosmological space–time.” By the words “comoving frame” is meant that she will not consider a geostatic solution to the data, even though the data allows such an interpretation.

University, who has worked very closely with Tegmark, recently submitted a paper on the WMAP and concluded that “a sphere” would be the most appropriate model to describe it,³⁶⁶ which is, of course, the precise shape of a geocentric universe.

In a recent publication, the team of Dominik Schwarz, Glenn Starkman, et al., discovered that:

The large-angle correlations of the cosmic microwave background exhibit several statistically significant anomalies compared to the standard inflationary cosmology....the quadrupole-octopole correlation is excluded from being a chance occurrence in a gaussian random statistically isotropic sky at >99.87%....The correlation of the normals with the ecliptic poles suggest an unknown source or sink of CMB radiation or an unrecognized systematic. If it is a physical sources or sink in the inner solar system it would cause an annual modulation in the time-ordered data....Physical correlation of the CMB with the equinoxes is difficult to imagine, since the WMAP satellite has no knowledge of the inclination of the Earth’s spin axis.³⁶⁷

In a related article in *Scientific American*, Schwarz and Starkman essentially say the same thing, but with a few more details. Comparing the CMB fluctuations to the sounds of an orchestra, they find that “Certain of those harmonics are playing more quietly than they should be....These bum notes mean that the otherwise very successful standard model of cosmology [the Big Bang] is flawed – or that something is amiss with the data.”³⁶⁸ Toward the end of the article Schwarz and Starkman more or less discount that something is wrong with the data, leaving the Big Bang theory itself as the culprit:

Yet the WMAP team has been exceedingly careful and has done numerous cross-checks of its instruments and its analysis procedure. It is difficult to see how spurious correlations could accidentally be introduced. Moreover, we have found similar correlations in the map produced by the COBE satellite....The results could send us back to the drawing board about the early universe.³⁶⁹

³⁶⁶ M. Tegmark and G. Efstathiou, *Monthly Notices of the Royal Astronomical Society*, 281, 1297, 1996.

³⁶⁷ Dominik J. Schwarz, Glenn D. Starkman, Dragan Huterer and Craig J. Copi, “Is the Low- l Microwave Background Cosmic?” *Physical Review Letters*, November 26, 2004, pp. 221301-1 to 4.

³⁶⁸ Glenn D. Starkman and Dominik J. Schwarz, “Is the Universe Out of Tune,” *Scientific American*, August 2005, p. 50.

Schwarz and Starkman then refer to the study of Tegmark and Oliveira-Costa we covered above, noting that the “preferred axes of the quadrupole modes...and the octopole modes...were remarkably closely aligned” (i.e., geocentric), and they add the study of Hans Kristian Eriksen in 2003 at the University of Oslo, citing that:

What they found contradicted the standard inflationary cosmology – the hemispheres often had very different amounts of power. But what was most surprising was that the pair of hemispheres that were the most different were the ones lying above and below the ecliptic, the plane of the earth’s orbit around the sun. This result was the first sign that the CMB fluctuations, which were supposed to be cosmological in origin...have a solar system signal in them – that is, a type of observational artifact.³⁷⁰

The significance of Eriksen’s finding may go over the heads of most people not familiar with astrophysical language, but the simple interpretation is that all the radiation in the universe, whether it is symmetric or asymmetric, is centered around the Earth (although because Eriksen is a Copernican he refers to it as “the plane of the earth’s orbit around the sun”). This is confirmed when Schwarz, *et al.*, state later: “Within that plane, they sit unexpectedly close to the equinoxes – the two points on the sky where the projection of the earth’s equator onto the sky crosses the ecliptic.” In other words, all the data show that, as far out as our telescopes can see, space is oriented geocentrically. What are the chances that this could happen by accident? The team of Copernicans has to admit that the “combined chance probability is certainly less than one in 10,000.” So upsetting is this evidence to the scientific *status quo* that another magazine, *New Scientist*, labeled the same universal orientation around Earth’s equatorial plane as, “**THE AXIS OF EVIL**,” since this geocentric picture virtually destroys its cherished Copernican principle.³⁷¹

In conclusion, all the investigations show that the characteristics of the CMB: (a) lean heavily against the Big Bang theory and (b) suggest that our local system (e.g., sun, Earth and planets) is either a central source or the central depository or “sink” for the CMB radiation. This means that the Earth and its neighbors are in the center of the phenomenon. He further adds that the positioning of the poles

³⁶⁹ Glenn D. Starkman and Dominik J. Schwarz, “Is the Universe Out of Tune,” *Scientific American*, August 2005, p. 55.

³⁷⁰ Glenn D. Starkman and Dominik J. Schwarz, “Is the Universe Out of Tune,” *Scientific American*, August 2005, p. 52.

³⁷¹ Marcus Chown, “Axis of Evil Warps Cosmic Background,” *New Scientist*, October 22, 2005, p. 19ff.

symmetrically above and beneath the sun's ecliptic is to be interpreted as no accident. The CMB poles couldn't position themselves in respect of the Earth's rotation or translation since the poles have no reaction to such movement. As such, the orientation of the CMB is purely geocentric.

In a recent interview, speaking for the team, Glenn Starkman of Case Western University stated: "All this is mysterious. And the strange thing is, the more you delve into it, the more mysteries you find." This is a polite way of saying that he is shocked that the CMB is geocentrically orientated, since that is the last thing he expected to find by working from a Big Bang model. Nevertheless, in an attempt to put a damper on the geocentric possibilities, Starkman adds: "None of us believe that the universe knows about the solar system, or that the solar system knows about the universe."³⁷² We see how the team's presuppositions determine how they will proceed to interpret the data. As always, the geocentric possibilities are summarily dismissed since such notions are, as we found earlier, "unthinkable" for the modern science community. As one physicist said: "The precise directional coincidences with solar system alignments are certainly thought-provoking. It may look like a smoking gun...but I'm going with the fluke hypothesis for now."³⁷³

³⁷² Dan Falk, *Astronomy Magazine*, December 8, 2004, p. 1-2.

³⁷³ Dan Falk quoting Craig Hogan of the University of Washington in Seattle, *Astronomy Magazine*, December 8, 2004, p. 1-2.

Quasars: Spherical Shells Around the Earth as Center

About ten years prior to the discovery of gamma-ray bursts, astronomers stumbled upon another unique phenomenon in the universe – quasars. Radio telescopes employed in the 1960s found radio waves being transmitted by objects outside the solar system. Optical telescopes were then pointed in the same direction. They found faint points of light, which they named “quasi-stellar radio sources,” soon shortened to “quasars.”

Quasars presented a problem soon after their discovery since, according to the popular theory wherein redshift is understood as representing a recessional velocity, the quasars would have to be moving away from Earth at tremendous speeds, some between 15% and 95% of the speed of light. If so, they were then thought to be on the outer edges of the known universe, which then meant, if we are able to see their light, they must be putting out tremendous amounts of energy, starting at about a thousand times the luminosity of a galaxy. Not only that, but since any given quasar will vary in brightness, this means that the lower ebb of the luminosity translated into the quasar being an amazingly small object.

Astrophysicist [Yatendra P. Varshni](#) did extensive work on the spectra of quasars. In 1975 he catalogued 384 quasars between redshift of 0.2 and 3.53 and, amazingly, found that they were formed in 57 separate groupings of concentric spheres around the Earth. He made the following startling conclusion:

...the quasars in the 57 groups...are arranged on 57 spherical shells with the Earth as the center....The cosmological interpretation of the redshift in the spectra of quasars leads to yet another paradoxical result: namely, that the Earth is the center of the universe.³⁷⁴

Varshni first based his calculations on the spectra of the quasars and then did a second test on their actual redshifts. Both tests produced

³⁷⁴ Varshni’s data, as cited in “The Red Shift Hypothesis for Quasars: Is the Earth the Center of the Universe?” *Astrophysics and Space Science*, 43: (1), (1976), p. 3. Although Varshni was firm on his discovery, he did leave room for an alternative explanation: “We are essentially left with only one possibility...the cosmological redshift interpretation. However, before we accept such an unaesthetic possibility, we must raise the question: Are the redshifts real? We wish to point out that we have proposed an alternative explanation of the spectra of quasars (Varshni, 1973, 1974, 1975; Menzel, 1970; Varshni and Lam, 1974) which is based on sound physical principles, does not require any redshifts, and has no basic difficulty.” Varshni’s alternative proposal was that the spectral lines were due to laser action in certain atomic species in the expanding envelope of a star (*Astrophysics and Space Science*, 37, L1, (1975)).

the same results. Varshni concludes that if his analysis is correct for quasars, then...

The Earth is indeed the center of the Universe. The arrangement of quasars on certain spherical shells is only with respect to the Earth. These shells would disappear if viewed from another galaxy or quasar. This means that the cosmological principle will have to go. Also it implies that a coordinate system fixed to the Earth will be a preferred frame of reference in the Universe. Consequently, both the Special and General Theory of Relativity must be abandoned for cosmological purposes.³⁷⁵

Varshni calculated the odds against such an arrangement and found:

From the multiplicative law of probability, the probability of these 57 sets of coincidences occurring in this system of 384 QSOs is $\approx 3 \times 10^{-85}$. We hope this number will be convincing evidence that the coincidences are real and cannot be attributed to chance.

Soon after Varshni's work, astronomers found over 20,000 quasars, and none of them altered Varshni's original results. In fact, they refer to it as the "quasar distribution problem." Of course, it's only a problem because, as Varshni was so bold to say, it puts a stake into the heart of the cosmological principle, as well as challenging the very tenets of the most prestigious work of science to date – Einstein's theory of Relativity. The other "problem," of course, is that since these quasars are distributed around Earth with such specific periodicity, this means that Earth is situated in a quasar-free hole, and that no other such "holes" exist anywhere else in the universe. Moreover, even if one were to dispute Varshni's findings by positing an alternative explanation for red-shift (e.g., the belief that red-shift does not measure distance), the 57 concentric groupings of quasars will appear nonetheless when put in terms of "phase space," which, in astrophysics, is a multidimensional view of the sky utilizing Cartesian dimensions coupled with time and momentum to plot positions on a map.

A year after Varshni's 1976 paper, C. B. Stephenson attempted to explain the startling findings by suggesting that the Big Bang produced

³⁷⁵ *Astrophysics and Space Science*, 43: (1) (1976), p. 8. Varshni cites a counter-explanation and shows its weakness: "Quasars may be arranged like atoms in a crystal lattice, with the Earth being either at an empty lattice site or at a suitable interstitial site. Should that be the case, one would expect some pattern or regularity in the directions of quasars belonging to a certain group. No such evidence is found and this possibility must also be abandoned" (*ibid.*).

periodic bands of quasars that spread out over time.³⁷⁶ Varshni wrote back to the same periodical a few months later critiquing Stephenson's proposal, saying:

Instead of having Earth at the center, now we have to assume that the Universe evolved in fits and starts of quasar production. The concept of preferred epochs for quasar production is hardly any more aesthetic than that of a preferred position for the Earth.³⁷⁷

Not only does Varshni's evidence of symmetrical spheres challenge the prevailing cosmological principle, but as is the case with gamma-ray bursts, another problem with quasars for modern cosmology is that the distances they are assumed to be from Earth in the Einstein universe requires them to put out so much energy in order to match their luminosity (at least 10,000 times the combined energy of Milky Way galaxy), that such energy is impossible to account for under current physical laws. Not only that, but putting quasars at such large distances would require them, under the current hypothesis of an expanding universe, to be moving away from Earth at speeds faster than the speed of light – an obvious contradiction to Einstein's theory (although some attempt to avoid this problem by claiming that as the quasar moves it "creates space," or that Einstein's limitations only apply to the speed of "information" and not to the actual speed of light). As one author put it:

When quasars were first discovered in the nineteen-sixties, they confronted astronomers and astrophysicists with an acute dilemma: If their enormous redshifts truly represented distance, nothing known in physics could explain their source of energy. Indeed, the very existence of such a compact but colossal source of energy seemed for a time to challenge the known body of physical principles, and a variety of fanciful notions

³⁷⁶ *Astrophysics and Space Science*, 51, 117-119 (1977).

³⁷⁷ *Astrophysics and Space Science*, 51, 121, 1977. Varshni's only other published criticism came from R. Weymann, T. Boronson and J. Scargle, who claimed that Varshni overestimated the significance of the clustering of quasar redshifts by many magnitudes (*Astrophysics and Space Science*, 53, 265, 1978). Varshni responded in an article titled "Chance Coincidences and the So-Called Redshift Systems in the Absorption Spectrum of PKS 0237-23," stating: "It is shown that the number of redshift systems based on C IV doublets, proposed by Boronson, *et al* (1978) in the absorption spectrum of the quasar PKS 0237-23, is significantly different from that which would be expected from chance coincidences. Consequently, these systems and their *z*-values appear to be devoid of any physical significance" (*Astrophysics and Space Science*, 74, 3, 1981).

like the “white hole” hypothesis were seriously considered in some quarters.³⁷⁸

Perhaps getting wind of Varshni’s results, in the same year a team of astronomers from California Institute of Technology led by Vera C. Rubin set out to disprove the geo- or galacto-centric findings. That they may have been motivated to refute Varshni’s findings is suggested by one conspicuous comment in their report reflecting the possible upsetting of their evidence: “Hopefully, it will not force a return to the pre-Copernican view of a hierarchy of motions whose sum is zero at the Sun.”³⁷⁹ The team set out to prove that the sum total of motions in the universe did not add up to zero in our local system, for a null sum would mean that the Earth-based observer was not in motion. Try as they may, the team was not able to rule out a null sum pointing to a geocentric universe. Within the allowable margin of error, they admitted that one possible solution to their findings was that all the motions in the galactic plane cancel out each other. Although they themselves advanced the

³⁷⁸ *Mosaic*, 9:18-27, May-June 1978. NB: A white hole is the theoretical porthole by which energy from another universe can be given to a quasar.

³⁷⁹ Vera C. Rubin, Norbert Thonnard and W. Kent Ford, Jr., “Motion of the Galaxy and the Local Group determined from the velocity anisotropy of distant Sc I galaxies,” *The Astronomical Journal*, vol. 81, No. 9, Sept. 1976, p. 735. In actuality, the “pre-Copernican” would have the “sum is zero” at the Earth, not the Sun. In any case, Rubin preferred a velocity for the Sun at 600 km/sec \pm 125 km/sec and a velocity of the Milky Way of 425 km/sec \pm 125 km/sec. The full paragraph reads: “If experiments underway or planned confirm the high degree of isotropy of the 2.7-K background radiation, and optical studies confirm a motion of the Sun, $V > 300$ km/sec, then the resolution of this conflict should enhance our knowledge both of the early history of the Universe and of the motions of galaxies, $r \sim 100$ Mpc. Hopefully, it will not force a return to the pre-Copernican view of a hierarchy of motions whose sum is zero at the Sun.” In their conclusion they admit: “This conflict remains unresolved” (*ibid.*, p. 736). Other clues to their motivation appear in various places: “If our Galaxy is at rest, values of ΔV_{GM} will be distributed at random for galaxies across the sky. However, if our Galaxy is moving, galaxies in the direction of the apex will have negative values of $V_C - V_H$ in the mean...” (*ibid.*, p. 722). The team states that “The overriding conclusion...is that...the anisotropy persists, and in such a fashion that the most acceptable explanation is a motion of our Galaxy,” yet admits that there are “A variety of solutions” (*ibid.*, p. 722) and “this conclusion puts such great weight on the few nearer galaxies that we choose to discuss the other alternatives as well” (*ibid.*, p. 728), and then they are forced to make a preference: “Employing Occam’s razor, we reject this hypothesis [a stationary Milky Way] in favor of the simpler one of a motion of the observer” [a moving solar system]. In addition, they admit: “If our Galaxy is at rest, then diameters of apex and antapex galaxies will be equal when diameters are formed from the galactocentric velocities. Alternately, if the Galaxy and the Local Group have a motion, the galaxy diameters will be equal...As can be seen, the rms errors of the diameters are too large to distinguish between the two cases” (*ibid.*, p. 730). Again, “While we prefer to interpret our results in terms of galactic motion, we admit the possibility that some fraction of the observed effect could arise from magnitude errors” (*ibid.*, p. 733).

view that the Sun and Galaxy were moving, the team was honest enough to conclude that they had no proof for this assertion.

Another study conducted in 1976 by Paul Schechter of the Steward Observatory analyzed the data of Rubin's team and sought to determine whether the results could be controverted, but found they could not. Schechter found the same canceling of galactic motion centered on the Earth-based observer as did the Rubin team.³⁸⁰

Not only does the new scientific evidence show us that Earth is in the center of these heavenly bodies, it may also require us to accept that the universe is much smaller than Big Bang hypothesizers have led us to believe. Note this admission from the previous author:

On the other hand, if the redshifts displayed by the object were false indicators of recession velocity, then the sources could be nearby and the problem of the energy source would go away. But the implications of this explanation were even more horrifying to astronomers. If some entirely unknown physical mechanism could mimic the Doppler displacement of the emission lines of a receding object, then the whole concept of an expanding universe would be thrown into question; the Hubble scale of cosmic distances an essential tool for both astronomers and cosmologists would have to be discarded.³⁸¹

³⁸⁰ Paul L. Schechter, "On the Solar Motion with Respect to External Galaxies," *Astronomical Journal*, vol. 82, August 1977, pp. 569-576. Schechter's abstract reads: "The ScI galaxy data by Rubin, Ford...have been examined to determine whether the accuracy of the solar motion derived from anisotropy in the redshift-magnitude diagram can be substantially improved by the application of the 'diameter correction' employed by Rubin et al. It is found that it cannot. Analysis of a sample of nearby bright galaxies gives a solution for the solar motion with three times the formal accuracy obtained with the ScI sample, but with a possible systematic error arising from the motion of the sample galaxies toward the Virgo cluster." Rubin likewise admitted that evidence from James Peebles (Princeton, 1976) indicated "a component of motion toward Virgo" but that Rubin's showed "a component...away from the Virgo direction," while data from Sandage and Tammann (1975a, 1975b) "does not support the observed anisotropy" that the Rubin team saw (Rubin, op. cit., p. 733). The practical ramifications of Rubin's inability to confirm her results is demonstrated in the opposing vectors touted by other astronomers in the same decade. Abell, for example, in *Exploration of the Universe*, asserts that we are moving toward the constellation Lyra at 20 km/sec, while Muller in *Scientific American* (May, 1978, p. 65) claims we are heading toward Leo at 400 km/sec, while Rubin has us moving "orthogonal to the Virgo cluster," which would be toward Gemini or Taurus. In a study by Smoot, Gorenstein and Muller, the 600 km/sec velocity [of Rubin] was "almost at right angles to the velocity with respect to the background" (Michael Rowan-Robinson, "Ether drift detected at last," *Nature*, Vol. 270, November 3, 1977, p. 9). Obviously, these contradicting results make the search for a movement of the Earth an exercise in futility. See also: Richard Warburton and John Goodkind, "The Search for Evidence of a Preferred Reference Frame," *Astrophysical Journal*, vol. 206, Sept. 1976, pp. 881-886.

³⁸¹ *Mosaic*, 9:18-27, May-June 1978.

Not only does Varshni's evidence compel him to dismiss Einstein's Relativity, but Edwin Hubble's theory that the universe is expanding is also suspect. Varshni's astounding evidence has also been confirmed by other astrophysicists, with even more extensive studies. The Ukrainian team of N. A. Zhuck, V. V. Moroz, A. A. Varaksin, who examined 23,760 quasars, confirm the following:

Regularity in quasar allocation...revealing that the quasars are grouped in thin walls of meshes [with] quasars spatial distribution in spherical and Cartesian coordinates...quasars have averages of distribution, root-mean-square diversion and correlation factors, typical for uniform distribution of random quantities; in smaller gauges the quasars are grouped in thin walls of meshes.... It is impossible to term these results, and the results of other similar investigations, as ordinary accidental coincidence. Obviously we have the facts confirming that the quasars are distributed uniformly in the universe...³⁸²

They conclude that the "quasars' allocation in meshes correlates with galaxy allocation," which means that the same spherical groupings noticed in quasars are also true for galaxies (which we will address in our next section).³⁸³

In addition, their evidence brings them to the same conclusion as Varshni's in the discovery of the distribution of his quasars. The Ukrainian team states that their result

"...confirms the concept of the stationary inconvertible universe and to reject [the] concept [of a] dynamic dilating universe which [was] erroneously formed in the XXth century and taking a beginning from a so-called Big Bang....Such a model is based on the non-steady solutions of the Einsteinian

³⁸² "Quasars and the Large Scale Structure of the Universe," N. A. Zhuck, V. V. Moroz, A. A. Varaksin, *Spacetime and Substance, International Physical Journal*, Ukraine, Vol. 2, No. 5 (10) 2001, p. 193, 196. The Zhuck team go on to say that "...meshes in which walls the quasars are concentrated not only change in size, but also that [which] is most important, [they] are deformed (are flattened) approaching the universe boundary that cardinally contradicts the theory of the explosion [i.e., the Big Bang] which is typical of the homogeneous expansion of a substance and, accordingly, proportional expansion of the sizes of the indicated meshes" (NB: I have added words in brackets, since the translation from Russian is rather choppy in certain instances.)

³⁸³ They write: "It is necessary to note, that in 1971 Karlsson has found out for the first time a cyclic change of a spectral radiant density of quasars proportional argument $\ln(1+z)$, where z is the red bias of their spectrums. Such allocation of quasars correlates with allocation of galaxies forming in the universe homogeneous thin-walled aggregations as meshes" (p. 206). Karlsson will also be mentioned in our next section on Galaxies. The reference is "Possible discretization of quasar redshift," *Astronomy and Astrophysics*, 13:333 (1971).

equations obtained by Soviet geophysicist and mathematician Friedmann at the beginning of the 1920s and the dynamics of the exploding commencement...advanced by American physicist Gamov at the end of the 1940s.”³⁸⁴

We should pause to note, as much as we cite the works of Varshni, Zhuck and others in showing the centrality of Earth in relation to the quantized distribution of quasars, we are not by any means adopting anyone’s opinion that the quasars are billions of light-years from Earth. The whole question of determining the distance of celestial objects is an inexact science, which we will address later in this book. Presently, the matter of whether quasar redshifts are intrinsic (that is, due to the nature of the object emitting the radiation, or even from the radiation’s loss of energy) or cosmological (that is, due to the great distance quasars are said to be from Earth), is a hotly debated topic.³⁸⁵

³⁸⁴ *Ibid.*, p. 202. The Zhuck team adds that the redshift does not necessarily have to be interpreted as “the expansion of the universe,” but as “the dissipation of the energy of light when it spreads at great distances.” In another place: “The analysis of interaction of light with the universe has shown that gravitational potential ($-c^2$) acts on it, giving power loss and, as a corollary, change frequency ν in relation to initial ν_0 under the law $\nu = \nu_0 e^{-r/R_0}$. The given law completely permits [the] photometer paradox, explains the nature of red bias in spectrums of radiation of other galaxies without engaging a Doppler effect and gives a new formula of definition of distance up to galaxies $L = R_0 \ln(1 + z)$, where z is the parameter of red bias in light frequency....The law completely explains the nature, numerical performances and character of allocation of background microwave radiation. Actually, it is not a relic of the Big Bang [but] aggregate radiation of all radiants of electromagnetic radiation (star, galaxies, etc.) of the universe...the light, when spreading in space, loses its energy since the light is permanently forced to break away from [the] gravitating masses behind” (pp. 205-207). Zhuck adds that this also answers Olber’s paradox: “The law ($\nu = \nu_0 e^{-r/R_0}$) has been completely proved by observations...by the missing of bright luminescence of the sky at night (contrary to a known photometer paradox of classical physics),” p. 209. (The reference to Friedmann appears in “Über die Krümmung des Raumes,” *Ztschr. Phys.*, 10:377-386, 1922 and 21:332-336, 1922; to Gamov in *Physical Review*, 70:572-573, 1946).

³⁸⁵ There has been an ongoing debate whether the redshift of quasars is intrinsic (that is, due to the nature of the quasar or the nature of the emitted radiation - a view proposed by William Tifft) or cosmological (due to the great distance quasars might be from Earth). Fred Hoyle and Geoffrey Burbidge claim that the “Compton catastrophe” disallowed the cosmological origin of quasar redshift, but this was supposedly answered by Ludwig Woltjer (see Katz: *The Biggest Bangs*, pp. 44-45). D. Basu in “The Hubble Relation for a Comprehensive Sample of QSOs” in *Journal of Astrophysics and Astronomy* (2003), 24, 11-21, examines Burbidge’s 1993 comprehensive data of 3000 QSOs and concludes redshifts of QSOs are of cosmological origin. Thomas Van Flandern proposes that redshift is caused by friction between the lightwave and the “classical graviton” medium through which it travels (*Pushing Gravity*, p. 118). Similarly, John Kierien offers that redshift is caused by the Compton effect, not the Doppler effect (“Implications of the Compton Effect Interpretation of the Redshift,” *IEEE Trans. Plasma Science* 18, 61, 1990). D. R. Humphreys has suggested the redshift is caused by the expansion of space itself, which he coincides with his support of General Relativity. Halton Arp postulates that redshift is intrinsic to the object, and since each object is different because it is “created” at a

Regardless of the outcome, however, identical to gamma-ray bursts, quasars exhibit the same type of quantized and spherical distribution in space, having Earth as the center point. So for now, we can appeal to the findings of the above named astronomers simply because the spherical *proportions* of quasar distribution having Earth as the center remain the same whether the quasars are near or far away.

Along these lines, astronomer [Halton Arp](#) has ample evidence in his two books positing that the Big Bang interpretation of redshift (i.e., redshift = distance) is fallacious.³⁸⁶ Nevertheless, Arp's alternative still recognizes the obvious periodicity of cosmic redshifts and classifies them as "apparent" velocities for the sake of common nomenclature.

Among his many proofs, Arp begins with the observational evidence from Burbidge and Karlsson:

In 1967 Geoffrey and Margaret Burbidge pointed out the existence of some redshifts in quasars which seem to be preferred (particularly $z = 1.95$. In 1971 K. G. Karlsson showed that these, and later observed redshifts, obeyed the mathematical formula $(1 + z_2)/(1 + z_1) = 1.23$ (where z_2 is next higher redshift from z_1). This gives the observed quasar redshift periodicities of: $z = 0.061, 0.30, 0.60, 0.91, 1.41, 1.96$, etc. In my opinion this is one of the truly great discoveries in cosmic physics...Many investigations confirmed the accuracy of this periodicity.³⁸⁷

different time, varying redshifts will be produced (*Seeing Red*, p. 195). We will have an in-depth analysis of this controversy later in our book. Suffice it to say for now, however, that the spherical patterns of quasar distribution observed in the universe are not dependent on one view of redshift or the other.

³⁸⁶ *Quasars, Redshifts and Controversies*, 1987; *Seeing Red: Redshifts, Cosmology and Academic Science* (Montreal, Apeion, 1998). Arp quotes those not disposed to accepting his observational data as saying "It's just noisy data" -- Joseph Silk, University of Calif., Berkeley; "We have a lot of crank science in our field" -- James Gunn, Princeton University; "I'm not being dogmatic and saying it cannot happen, but..." -- James Peebles, Princeton University; (*Seeing Red*, pp. 199-200).

³⁸⁷ *Seeing Red*, p. 203. Arp adds: "And of course, many claimed it was false. One postdoctoral student at the Institute of Theoretical Astronomy in Cambridge...claimed there was no periodicity. His analysis included the faintest, least accurate quasars which had been shown not to exhibit periodicity. They showed it anyway. In a new sample of x-ray quasars, he found the periodicity but issued the opinion that it would go away with further measures (fainter quasars). We will see the opposite happened" (*Ibid.*, p. 203). Arp records another attempt to dismiss his data: "Now one of the ongoing attempts to discredit the redshift periodicity was an argument that quasars were discovered by their ultraviolet excess and that excess was caused by prominent emission lines moving into the ultraviolet window at certain redshifts -- in other words the periodicity was merely a selection effect. It had been shown that this was not the case, but nevertheless the argument was widely accepted as disproving this embarrassing observational result" (*Ibid.*, p. 204).

From another publication, Arp adds: “This has most lately been confirmed for all quasars known through 1984 by Depaquit, Vigier and Pecker.”³⁸⁸ Added to this is the thorough investigation by the Chinese couple H. G. Bi and X. Zhu who, with power spectrum analysis, investigated the periodicity findings in all the data and found that the predicted periodicities (i.e., $z = 0.061, 0.30, 0.60, 0.91, 1.41, 1.96$, etc.) fit the formula by 94-99.5%. With more refinements, Arp states: “...the confidence is 99.997% or only one chance in about 33,000 of being accidental.”³⁸⁹

³⁸⁸ “The Observational Impetus for Le Sage Gravity,” Max Planck Institut für Astrophysik, 1997. Burbidge wrote about the same phenomenon in *Mercury* in the article “Quasars in the Balance,” 17:136 in 1988. Arp has provided the most information in his book *Quasars, Redshifts and Controversies* (1987) and *Seeing Red: Redshifts, Cosmology and Academic Science* (1998). He and Burbidge wrote of their work in *Physics Today*, 37:17, in 1984, in the article “Companion Galaxies Match Quasar Redshifts: The Debate Goes On.”

³⁸⁹ *Seeing Red*, p. 204.

Periodicity of BL Lacertae and X-Ray Redshifts

BL Lacertae (or BL Lac) objects are somewhat between a quasar and a galaxy, since their spectra are dominated by a non-thermal radiation, but one that is continuous and which features radio and X-ray emissions. Although more rare, they are similar to quasars, and one would expect BL Lac's to have the same periodicity. Indeed they do. Interestingly enough, the data supporting this is documented in one of the standards of the industry, the 1995 *Véron and Véron* catalogue, but no one until Arp had ever noticed it. The catalogue's graph shows BL Lac distribution occurring in redshift clumps of 0.30, 0.60 and 0.96 km/sec. This precise periodicity, of course, is giving the same evidence of the centrality of Earth that gamma-rays and quasars have given. Arp, even though he is an avowed heliocentrist, aptly recognizes the data as the "anti-Copernican embarrassment," as he calls it, but has no real solution to combat it. Although he escapes the clutches of the Big Bang by theorizing that redshifts are caused by the intrinsic nature of "young matter," and hypothesizes that quasars have a high redshift because they are new matter "ejected from galaxies," Arp is still left with the periodicity of the galaxy-quasar pairs that come in the mathematical intervals noted above, and thus, as to the position of the Earth in the exact center of these periodicities, Arp has no further explanation.

The same periodicity was found of X-ray clusters using the German-built X-ray telescope, [ROSAT](#). In a survey conducted by Marguerite Pierre, et al. Arp writes:

The most amazing thing about this investigation is perhaps the obvious non-random distribution of the X-ray clusters in this region of the sky and the failure of the investigators to comment on it. Perhaps the next most amazing aspect is that the largest grouping of the brightest X-ray clusters in this whole region conspicuously coincided with the brightest galaxies in the region – but went unremarked.³⁹⁰

So here we see that when the evidence of periodicity is plainly obvious, either the world's astronomers are so conditioned by the Big Bang theory that espouses random and homogeneous distribution of cosmic matter that they simply are oblivious to the opposing evidence or they are ignoring the evidence deliberately. Some Big Bang cosmologists, following the proposal of Claude Canizares, have posited that gravitational lensing is responsible for the periodicity of quasar redshifts – a theory holding that the foreground galaxy acts as a giant lens that magnifies and displaces the apparent position of the quasar. But even after being shown that gravitational lensing could not explain the phenomenon, one cosmologist retorted: "We interpret this observation as

³⁹⁰ *Seeing Red*, p. 158.

being due to the statistical gravitational lensing of background QSO's [quasars] by galaxy clusters. However, this...cannot be accounted for in any cluster lensing model."³⁹¹ In other words, they assert an interpretation that will support their views, but they lack a workable model of how it could occur, let alone possess observational evidence to support their interpretation.

³⁹¹ *Seeing Red*, p. 171. This was stated four years after *Astronomy and Astrophysics* (229, 93, 1990) carried a peer-reviewed article showing that gravitational lensing could not account for the phenomenon. The unmitigated bias of the scientific establishment was demonstrated when NASA, which allowed amateur astronomers an opportunity to use the Hubble Space telescope, quickly discontinued the program after the amateurs found evidence of quantized quasars near galaxies that were flatly against the Big Bang theory, with NASA then claiming that the program had been "too great a strain on its expert personnel" (cited in James P. Hogan's *Kicking the Sacred Cow*, pp. 101-102).

Galaxies: Spheres of Stars Around Earth as Center

The above astronomers are not the only ones to discover such quantized and spherical distribution of the heavenly bodies centered on the Earth. In 1970, William G. Tift, astronomer at Steward Observatory at the University of Arizona examined the redshift of various galaxies and found that they were all distributed at specific spherical distances from Earth, namely, in multiples of 72 km/sec, and a smaller grouping of 36 km/sec.³⁹²

To picture this in your mind's eye, it is like bands of galaxies, with each band separated from the other in evenly spaced and proportional rings. Tift's findings were quite shocking to the field of astronomy, since not only were the more obscure sources such as gamma-rays and quasars showing Earth in the center of the universe, but now the common galaxy, which was far more numerous and readily observable, was showing precisely the same centrality of the Earth. Tift's work went through the usual rigor of peer-review, but astronomers were still reluctant to accept his findings, since they were well aware of the dire implications it held against their cherished Big Bang theory.

Sky and Telescope, which is not by any means a geocentrist periodical, says of Tift's results: "Quantized redshifts just don't fit into this view of the cosmos [the Big Bang view], for they imply concentric shells of galaxies expanding away from a central point, Earth."³⁹³

Ironically, Tift couldn't quite come to embrace his own results. In one of his more recent and comprehensive papers he writes:

The most obvious effect is the quantization of redshifts when viewed from an appropriate rest frame, especially the cosmic background rest frame. The redshift has imprinted on it a pattern that appears to have its origin in microscopic quantum

³⁹² Tift writes: "There is now very firm evidence that the redshifts of galaxies are quantized with a primary interval near 72 km s⁻¹" (W. G. Tift and W. J. Cocke, "Global redshift quantization," *Astrophysical Journal* 287:492-502, 1984). Also published in "Global Redshift Periodicities: Association with the Cosmic Background Radiation," *Astrophysics and Space Science*, 239, 35 (1996); "Evidence for Quantized and Variable Redshifts in the CBR Rest Frame," *Astrophysics and Space Science*, 1997. Also Tift and Cocke in *Sky and Telescope*, 73:19, 1987: "Quantized Galaxy Redshifts," as well as in *New Scientist* of June 22, 1985: "Galaxy Redshifts Come in Clumps," and Tift in Star, *Galaxies and Cosmos*, 1977.

³⁹³ "Quantized Redshifts: What's Going on Here?" *Sky and Telescope*, August 1992, p. 128 (84:128); see also January 1987, p. 19 and November 1973, p. 289. Halton Arp writes: "The fact that measured values of redshift do not vary continuously but come in steps... is so unexpected that conventional astronomy has never been able to accept it, in spite of the overwhelming observational evidence" (*Seeing Red: Redshifts, Cosmology and Academic Science*, p. 195).

physics, yet it carries this imprint across cosmological boundaries. A hierarchy of quantized domains is suggested.³⁹⁴

Typical of the paradigms into which modern scientists often lock themselves, Tiftt, rather than accept the face-value explanation that the galaxies are distributed in periodic distances from his telescope, opted for the *ad hoc* idea that something was “imprinted” on the light as it traveled from the galaxies to the Earth that merely made it appear as if it had come in quantized groupings. He also recognizes that even these “imprints” are quantized only when “viewed from an appropriate rest frame,” but he deliberately ignores the rest frame upon which his telescope is seated, namely, Earth, and arbitrarily chooses the ubiquitous “cosmic background” (the CMB) as his preferred absolute. Tiftt often refers to the “CBR rest frame” in his paper, but if he believes any such entity is to be understood as a “rest frame” then he certainly can’t hold to the theory of General Relativity that brought him the Big Bang, since the theory doesn’t possess any rest frames.

In any case, recognizing the anti-Copernican implications of Tiftt’s work for what they really were, in 1991, with the express purpose of overturning Tiftt’s results, astronomers Bruce N. G. Guthrie and William M. Napier of the Royal University at Edinburgh compared the redshifts from 89 single spiral galaxies. To their astonishment they found a periodicity of 37.2 km/sec, which was very close to Tiftt’s recently revised quantum multiple of 36.2 km/sec for this class of galaxies. As Robert Matthews states:

So unbelievable was this phenomenon that, when they first submitted their paper to *Astronomy and Astrophysics* a referee asked them to repeat their analysis with another set of galaxies. This, Napier and Guthrie did with 117 other galaxies. The same 37.5 km/sec figure thrust itself out of the data; and their paper was accepted.³⁹⁵

As a true scientist, Matthews understands quite well the implications of Napier’s and Guthrie’s exhaustive study. Like Varshni, he spares no words indicating how this evidence systematically overturns all prevailing theories of the cosmos:

³⁹⁴ W. G. Tiftt, “Global Redshift Periodicities and Variability,” *The Astrophysical Journal*, 485: 465-483, August 20, 1997, p. 465. Tiftt’s purpose in giving this alternate explanation, of course is to protect “a singular origin of the universe...and other early universe effects” (*ibid*).

³⁹⁵ “Do Galaxies Fly through the Universe in Formation?” *Science*, 271:759 (1996). So surprising is this information that M. Disney, a galaxy specialist from the University of Wales, stated: “It would mean abandoning a great deal of present research.” James Peebles, a cosmologist from Princeton University, stated: “...it’s a real shocker” (*Science Frontiers*, No. 105: May-June 1996).

Unless Napier and Guthrie and, of course, W.G. Tifft, the discoverer of IT, can be proven wrong, all of modern astronomy and cosmology will be in jeopardy: the expanding universe, the big bang, the presumed age of the universe, not to mention the endless assertions that these are all facts not theories.³⁹⁶

D. Koo and R. Krone, two University of Chicago scientists, did the same kind of redshift analysis on galaxies. Their results were identical to Napier's and Guthrie's and even made it to the *New York Times*. They conclude: "...the clusters of galaxies, each containing hundreds of millions of stars, seemed to be concentrated in evenly spaced layers" [i.e., concentric spheres around the Earth].³⁹⁷ Incidentally, for those who see symbolic significance in numbers, the number of "evenly spaced layers" discovered by each team of astronomers is seven. There are seven evenly-spaced layers in the north direction, and seven evenly-spaced layers to the south. Koo admits that astronomers are very disturbed at this spacing, obviously because it gives evidence of intelligent design and geocentrism.

Added to this evidence is the astonishing fact that the most distant galaxies (e.g., those said to be 10 billion light years away from Earth) look very much the same as the galaxies very close to us.³⁹⁸ This creates an intractable problem for current cosmology. The most distant galaxies should logically appear 9-10 billion years younger in their formation, since their light took that long to arrive on Earth. One could possibly explain this discrepancy by asserting that galaxies mature very fast and level off after a billion years, but that, of course, would not only be an *ad hoc* answer, it would conflict with other accepted understandings of current cosmology regarding galaxies.

Not only do the galaxies look the same, but various groups of galaxies are so large that, given modern cosmology's estimate as to the rate galaxies and clusters form, it would be impossible for these massive structures to form with the little time afforded by the Big Bang theory (a common complaint raised by Steady State theorists). For example, A few years ago astronomers discovered the Great Galactic Wall, which is a mass of galaxies 500 million light-years by 300 million light-years by 15

³⁹⁶ *Ibid.*

³⁹⁷ Malcolm Browne, *In Chile, Galaxy-Watching Robot Seeks Measure of Universe*, *New York Times*, Dec. 17, 1991. D. Koo, and R. Krone, *Annual Review of Astronomy and Astrophysics*, 30, 613 (1992). In 1981 R. Kirshner discovered three separate immense and widely separated voids in space with no galaxies at the interval of 12,000 to 18,000 km/sec ("Deep Redshift Survey of Galaxies Suggest Million-MPC3 Void," *Physics Today*, 35:17-19, January 1982).

³⁹⁸ "Most Distant Galaxies Surprisingly Mature," *Science News*, 119:148, 1981.

million light-years in total area. In 1989, *Science* magazine admitted that such a structure could not have been formed in the 15 billion years then assigned to the age of the universe.³⁹⁹ The only possible way would be for the Great Galactic Wall to have at least 100 times the mass it presently has, which prompted Stephen Hawking to comment: “Either we have failed to see 99% of the universe, or we are wrong about how the universe began.”⁴⁰⁰ Hawking’s admission is magnified by the fact that, as noted above, thirteen additional “Great Walls” of galaxies have been discovered since his comment was made in 1989.⁴⁰¹

The importance of the foregoing evidence regarding the periodic distribution of galaxies is brought out when contrasted to its opposite. As Harold Slusher puts it:

If the distribution of galaxies is homogeneous, then doubling the distance should increase the galaxy count eightfold; tripling it should produce a galaxy count 27 times as large. Actual counts of galaxies show a rate substantially less than this. If allowed to stand without correction, this feature of the galaxy counts implies a thinning out with distance in all directions, *and that we are at the very center of the highest concentration of matter in the universe....This would argue that we are at the center of the universe.*

When galaxy counts are adjusted for dimming effects, it appears that the number of galaxies per unit volume of space increases with distance. *From this we still appear to be at the center of the universe,* but now it coincides with the point of least concentration of matter.⁴⁰²

The war between Big Bang theorists and their opponents wages even more fiercely as time goes on. As of this writing, in a recent article titled “No Quantized Redshifts,” *Sky and Telescope* noted that a 2002 study conducted by Edward Hawkins and his colleagues at the University of Nottingham, England, revealed contrary evidence:

³⁹⁹ From the work of Margaret J. Geller and John P. Huchra of the Harvard-Smithsonian Center for Astrophysics; *Science*, November 17, 1989, as cited in *The Biblical Astronomer*, Vol. 2, No. 61, p. 11.

⁴⁰⁰ *Ibid.*, p. 11-12.

⁴⁰¹ See also *Astronomy*, “A Cross-Section of the Universe,” November 1989; “Southern Super Cluster Traced Across the Sky,” January, 1990; “Sky Survey Reveals Regularly Spaced Galaxies,” June 1990; *Sky and Telescope*, “The Great Wall,” January 1990; “A Universe of Bubbles and Voids,” September 1990, *ibid.*

⁴⁰² Harold S. Slusher, *The Origin of the Universe: An Examination of the Big Bang and Steady State Cosmologies*, El Cajon, CA, Institute for Creation Research, 1980, pp. 12-13, emphasis added.

...Hawkins...recently sifted through the massive new 2dF [Two Degree Field] redshift surveys of galaxies and quasars to test this idea. These surveys provided “by far the largest and most homogeneous sample for such a study,” writes Hawkins in the October 11th *Monthly Notices* of the Royal Astronomical Society....Among 1,647 galaxy-quasar pairs, no sign of any quantized redshifts appears.⁴⁰³

This study was specifically designed to test Arp’s theory that various galaxies and quasars occupy the same vicinity; the former producing the latter when material from the galaxy is ejected. If Arp is right, then obviously quasars are not at “cosmological” distances from Earth, that is, they are not at the farthest reaches of the universe. In addition, Arp holds that the redshifts of these galaxy-pairs are quantized, that is, they appear in regular intervals and thus are not representative of a homogeneous universe. Both of these (i.e., pairing and quantization) would be impossible to explain from a Big Bang perspective.

Out of 250,000 galaxies and 30,000 quasars, the Hawkins team limited their study to 1647 galaxy-quasar pairs for the purposes of “quality control.” Of these pairs they state:

No periodicity leaps off the page, but since the effect is likely to be quite subtle, one would not necessarily expect to be able to pick it out from the raw data, so it is important to carry out a rigorous statistical analysis.⁴⁰⁴

This, of course, opens the door for disagreements over the statistical data. At this point, opposing sides point the finger at each other. The Hawkins team determines that: “one can manipulate the data in order to specify ones own more optimal window – a procedure that statisticians whimsically refer to as ‘carpentry,’” and they conclude that “...the previous detection of a periodic signal arose from the combination of noise and the effects of the window [statistical] function.”⁴⁰⁵ Followers of the Arp team see it quite differently. [Geoffrey Burbidge](#) asserts that the entire work of the Hawkins team “is a real piece of dishonesty,” since Burbidge’s colleague, William Napier, had already pointed out a serious statistical flaw in Hawkins’ analysis before he published his paper. Napier subsequently submitted a rebuttal to the Royal Astronomical Society alerting the society to Hawkins’ flaw, as well as citing a recent Hubble photograph showing that one of the pairs

⁴⁰³ Alan M. McRobert, *Sky and Telescope*, December 2002, p. 28.

⁴⁰⁴ E. Hawkins, S. J. Maddox and M. R. Merrifield, “No periodicities in 2dF Redshift Survey data,” *Monthly Notices of the Royal Astronomical Society*, Vol. 336, Is. 1, October 2002, p. L15.

⁴⁰⁵ *Ibid.*, p. L16, L17.

studied by Hawkins had a luminous filament that physically connected the galaxy to the quasar!⁴⁰⁶ Although Hawkins asserts that he and his team “attempted to carry out this analysis without prejudice,” Burbidge concludes that the resistance of Hawkins and other Big Bang theorists is due to the “sociological problem associated with the need to believe” that redshifts are related to distances.⁴⁰⁷

Burbidge has a lot on his side. As of January 2005, his research led to the discovery of a quasar situated almost at the very center of a spiral galaxy, NCG 7319.⁴⁰⁸ Obviously, this phenomenon cannot be dismissed by “statistical analysis,” unless opponents attempt to argue that the galaxy’s core is transparent and allows us to see the quasar as if one is looking through a peephole, an argument that no one seems willing to undertake.

In regard to the geocentric question, the battle between the Big Bang theorists and the followers of Halton Arp leaves geocentrism, at worst, in a neutral position and, at best, drawing support from both sides of the aisle. On the one hand, Big Bang theorists are more or less caught between the proverbial rock and a hard place since, as Arp points out, they have created the same “Copernican dilemma” that we saw earlier with the evidence from gamma-ray bursters. As Arp states in critique of the Big Bang theory: “For supposed recession velocities of quasars, to

⁴⁰⁶ William Napier and Geoffrey Burbidge, *Monthly Notices of the Royal Astronomical Society*, 2003, 342, pp. 601-604.

⁴⁰⁷ Govert Schilling, “New results reawaken quasar distance dispute,” *Science*, October 11, 2002. Schilling adds that a recent Hubble photograph produced by Space Telescope Science Institute of the galaxy-quasar pair NGC 4319 (at $z = 0.006$) and Markarian 205 (at $z = 0.070$), respectively, showed no luminous bridge connecting the two thus implying that the bridge didn’t exist, contrary to Arp’s assertion. Arp, accusing STSI of “deliberately misleading the public,” obtained an enhanced photo of the Hubble photograph that clearly shows a bridge. Confirming Arp’s contentions, a recent report showed that galaxy NGC 7603 and its companion quasar each had very different redshifts but were physically linked by a luminous bridge. The authors concluded it was “the most impressive case of a system of anomalous redshifts discovered so far” (M. Lopez-Corredoira and C. Gutierrez, *Astronomy and Astrophysics*, 2002, 390, pp. L15-18). The higher redshift for the quasar, Arp maintains, is due to it being newly formed from the much older galaxy. The same is true for galaxies NGC2775 and NGC2777, which, contrary to conventional wisdom proposing they were merging, is an example, according to Arp, that the former produced the latter, which was confirmed by the fact that the latter had no metal in its spectral lines as well as a much higher redshift than the former. In addition, the galaxies were connected by an “umbilical cord of neutral hydrogen” (Halton Arp, *Seeing Red*, Montreal, Apeiron, 1998, p. 103). Big Bang theorists have proposed that the higher redshifts of the quasars is due to gravitational lensing, but Arp retorts that lensing cannot be the cause since the quasar aligns itself along the minor, not major, axis of the host galaxy. For the record, Arp had the support of Fred Hoyle in the 1981 book *The Quasar Controversy Resolved* and in 2000 with *A Different Approach to Cosmology*.

⁴⁰⁸ *Astrophysical Journal*, February 10, 2005.

measure equal steps in all directions in the sky means *we are at the center of a series of explosions. This is an anti-Copernican embarrassment.*⁴⁰⁹ In other words, regardless whether quasars are at cosmological distances, the fact that all the quasars are moving away from us at the same speed (as measured by the redshift-distance relation) means that Earth is precisely in the center of the dispersion. On the other hand, Arp has created his own Copernican dilemma. First, as Varshni concluded 30 years ago, quantized redshifts show irrefutable evidence of Earth's centrality. Second, Arp's siding with redshift as an indication of age rather than distance evaporates the need for a huge universe. In fact, it is possible given Arp's calculations that we would have a universe only a little larger than Ptolemy's, and certainly nothing big enough to accommodate 13.5 billion years of evolution. As James Hogan says, "No wonder the Establishment puts Arp in the same league as the medieval Church did Giordano Bruno."⁴¹⁰ In the end, whether redshift is cosmological or intrinsic, today's scientists have little escape from geocentrism.

⁴⁰⁹ *Seeing Red: Redshifts, Cosmology and Academic Science* (Montreal, Aperia, 1998), p. 195 (emphasis added).

⁴¹⁰ James P. Hogan, *Kicking the Sacred Cow*, New York, Baen Publishing Enterprises, 2004, p.105.

Geocentrically Oriented Spectroscopic Binaries and Globular Clusters

Recent data has shown that the periastron points of over one thousand spectroscopic binary stars are located farther away from Earth than their apastron points.⁴¹¹ In astrophysical terms this means that the orbital axis of binaries are situated with respect to the Earth. Since binary stars are seen over the 360 degrees of visual space, this means that the axis of each binary system is pointing toward the Earth as if the Earth were the center of a giant merry-go-round and the axes were arrows. Without admitting to any possibility that the binaries show Earth is in the center of the universe, astronomers instead prefer to attach innocuous names to such phenomena, this particular one being called the “Barr effect,” after the astronomer J. M. Barr. Barr’s original study found that of the 30 spectroscopic binaries he analyzed, 26 had longitudes of periastron between 0 and 180 degrees, which means that they were oriented toward Earth as their center.

In this light, it is interesting to see how even dissident physicists try to escape the implications of the “Barr effect” in dictating an Earth-centered universe. Dewey B. Larson, for example, is an anti-Big Bang advocate who has made quite a name for himself in science by denying the existence of black holes; as well as pointing out the anomalies of rotating galaxies and globular clusters, but he suddenly finds himself trying to downplay the observational evidence clearly demonstrated by the Barr effect. He writes:

Until the time of Copernicus, virtually everyone believed that the Earth was the center of the physical universe. Although we often blame Aristotle and St. Thomas Aquinas for perpetuating this belief, it was a natural and apparently self-evident deduction from simple observations. This, more than any one person’s authority, probably accounted for the belief in the central position of the Earth being elevated to dogma. Copernicus began to free us from the false notion, and now we have almost adopted an opposing dogma. Instead of being content to believe that the Earth is not in a central position, we often speak as if we believe that it cannot be. Confronted with a result like Barr’s therefore, astronomers tend either to be skeptical about it, or to look for some systematic error in the observations that will account for it. In the present instance, these instincts are probably sound; it is more unlikely that some preferred direction exists for the orientation of the major axes of binary orbits with respect to our line of sight from Earth.⁴¹²

⁴¹¹ The periastron is the point at which the two stars are closest to each other. The apastron is the point that the stars are farthest away from each other.

⁴¹² Dewey B. Larson, “Globular Clusters,” *The Universe in Motion*, North Pacific Publishers, Portland, Oregon, 1984, pp. 33, 37. In 1979, the “Barr effect” was verified

As we saw earlier with Jonathan Katz and the evidence from gamma-ray bursts, we find it interesting that Dewey has absolutely no hesitation in associating the phenomenon of Earth-oriented binary stars with the demise of Copernican cosmology. But, like Katz, he won't allow his mind to agree with what his eyes see. Rather, he allows himself the breathing room of looking for "some systematic error in the observations" so that he isn't required to make the evidence part of his scientific psyche. In any case, at least the evidence has made Dewey switch from the "cannot" position to the "is not" position. As for St. Thomas Aquinas, he indeed was a geocentrist, and it was based on his belief in divine revelation. Thomas writes:

The Earth stands in relation to the heaven as the center of a circle to its circumference. But as one center may have many circumferences, so, though there is but one Earth, there may be many heavens.⁴¹³

Lastly, we have evidence from globular clusters, which are conglomerations of thousands of loosely fitting stars. They form a spherical distribution around our nearest stars, and effectively, around the Earth. Dewey Larson writes:

The distribution of [globular] clusters around the Galaxy is nearly spherical, and there is no evidence that the cluster system participates to any substantial degree in galactic rotation....We see the globular clusters as a roughly spherical halo....The cluster concentration gradually decreases until it reaches the cluster density of intergalactic space...⁴¹⁴

Astronomers Victor Clube and William Napier found the same evidence, showing that globular clusters, while being independent of the galaxy in that they do not participate in the rotation of the same, show a radial dispersion from the center of the galaxy and conclude that "It is extremely difficult to explain these observations by any other kind of

in measurements of over 1,000 spectroscopic binaries, as reported by astronomer M. G. Fracastoro (A. H. Batten, "The Barr Effect," *Journal of the Royal Astronomical Society of Canada*, 77:95, 1983). Some astronomers have attempted to dismiss the Barr effect by claiming that hot gases are distorting the spectroscopy of the binaries, but others retort that no one has ever proved that the spectra of hot gas streams are combined with the spectra of stars to produce a Barr effect.

⁴¹³ *Summa Theologica*, "Treatise on the Work of the Six Days," Question 68, Article 4. By "many heavens" Thomas is referring to the three ways in which Scripture uses the word "heaven" (the Earth's atmosphere; the starry cosmos; and the third heaven as God's domain above the firmament).

⁴¹⁴ Dewey Larson, "Globular Clusters," *The Universe of Motion*, pp. 33, 37.

model.”⁴¹⁵ In other words, all the evidence leads to a geocentric universe.

⁴¹⁵ Victor Clube, “Do We Need a Revolution in Astronomy,” *New Scientist*, 80:284, 1978. Victor Clube and William Napier, “Universe to Galaxy: The Cosmic Framework,” *The Cosmic Serpent*, New York, 1982, p. 41.

Quantized Planetary Orbits

That the precise and characteristic periodicity of gamma-rays, quasars, BL Lacs, X-ray clusters, and galaxies are not merely some fluke of nature is supported by the fact that the orbits of the planets in our own region of the sky use the same ratios. One of Arp's students, Jess Artem, initiated this discovery when he showed in 1990 that the Titius-Bode Law of planetary distances matches the preferred redshift of quasars, since both are based on the ratio 1:1.23.⁴¹⁶ Arp himself discovered that, after obtaining the most modern estimates of planetary masses, their ratios fell in the 1.23 factor.⁴¹⁷ The chance of this occurring by accident is less than 1 in 1300.⁴¹⁸

This unique ratio also extends to the micro-world, since it has been shown that the electron orbits in the Bohr model of the atom are based on the factor of 1.23. Interestingly enough, in 1916 Arnold Sommerfeld modified Bohr's circular orbits to show that electrons were more stable in elliptical orbits, since they could move inwardly and outwardly without radiating or absorbing energy. Sommerfeld's work

⁴¹⁶ That is, $(1 + z_n)/(1 + z_0) = (1.23)^n$. The Titius-Bode law, which is based on a sequence that varies as 2^n , works well until Neptune and Pluto are added. Titius-Bode was then modified by Blagg-Richarson with a value of 1.7275^n , and with corrections. In the geocentric version of the Titius-Bode law, the sun and Earth merely switch places. O. Neto in Brazil; Agnese and Festa in Italy; L. Nottale in France; and A. and J. Rubčić in Croatia found that the proportional distances of the planets from the sun matched the distances of shells in the Bohr atom, using the common value of 144 km/sec (found among quasar redshifts) divided by 3, 4, 5, 6, 11, 15, 21, 26, 30, respectively.

⁴¹⁷ Although Arp used 1.2282 and calculated from the smallest planet to the largest, we will use 1.23 and use Earth as the control mass from which to compare the eight planets. Masses are in 10^{24} kilograms. "Actual" masses are the best estimates of the planets based on Newton's laws, but are, nevertheless, only approximate values, due to the complexity of planetary orbits, the sun's minimal angular momentum, the presence of moons, rings, and other factors among the planets. From a geocentric perspective, with Earth as the control mass at 5.9742×10^{24} kg, then:

- Mass of Earth x 1.23 = mass of Venus (4.8570) (actual: 4.8690).
- Mass of Earth x 1.23 (11x) = mass of Mars (0.6128) (actual: 0.64191)
- Mass of Earth x 1.23 (14x) = mass of Mercury (0.3293) (actual: 0.33022)
- Mass of Earth x 1.23 (28x) = mass of Pluto (0.018) (actual: 0.015)
- Mass of Earth x 1.23 x 13 = mass of Uranus (88.11) (actual 86.625)
- Mass of Earth x 1.23 x 14 = mass of Neptune (108.38) (actual 102.78)
- Mass of Earth x 1.23 x 22 = mass of Saturn (567.79) (actual 568.50)
- Mass of Earth x 1.23 x 28 = mass of Jupiter (1966.17) (actual 1898.80)
- Mass of Earth x 1.23 x 61 = mass of Sun (1.82×10^{30}) (actual 1.989×10^{30})
- Mass of Earth/Planets (2.668×10^{27}) x 1.23 x 32 = mass of Sun (2.00×10^{30})

⁴¹⁸ *Apeiron*, April 1995, p. 42.

also led to the discovery that electrons spin while in orbit.⁴¹⁹ These discoveries, of course, have an uncanny resemblance to the orbits of the planets, as well as the spin some of them possess.

If Earth is in the center of the universe, then not only is our planetary system unique in the sense of position, but evidence shows it is also unique insofar as its contents. Astronomers reporting in the prestigious *Monthly Notices of the Royal Astronomical Society* state: “in the past 10 years, over 100 extrasolar systems have been discovered from the wobble in their host stars, caused by the motion of the planets themselves.” The BBC reported: “none of them seem to resemble our Solar System very much. In fact, these exoplanets have several important attributes that are entirely at odds with the Solar System as we know it.” The lead researcher, Dr. Martin Beer of the University of Leicester’s theoretical astrophysics group stated: “But existing data suggests that the planets in the Solar System are truly different from other planets,” concluding that the search for Earth-like planets around other stars may be in vain. Most exoplanets are gargantuan and gaseous masses like Jupiter; are very close to their stars; and follow highly eccentric or elliptical orbits. Planets similar to Earth are virtually absent. Beer’s concludes: “The existing data leaves open the possibility that [our own planetary system] is quite unique compared to [others]...”⁴²⁰

⁴¹⁹ J. Mehra and H. Reichenberg, *The Historical Development of Quantum Theory*, Vol. 1, Part 1: “The Quantum Theory of Planck, Einstein, Bohr, and Sommerfeld: Its Foundation and the Rise of Its Difficulties” (1900-1925), New York: Springer-Verlag, 1982.

⁴²⁰ Jacqueline Ali, British Broadcasting Company News, 2004/08/06.

The Sloan Digital Sky Survey

As one thing leads to another, astronomers are very anxious to use their tools to map out the visible universe. Prompted by the above studies and figures, even more sophisticated equipment, backed by even more institutional money, the Sloan Digital Sky Survey is in operation to give what astronomers regard as the most accurate mapping of the galaxies, quasars, and other objects in the universe to date, and probably for some time to come. As noted in connection with the data from the CMB, Max Tegmark and a group of over 200 astronomers from 13 different institutions are involved in this project. As of this date, they have mapped over 200,000 galaxies. In the words of its own authors, the Sloan Digital Sky Survey or SDSS:

...is the most ambitious astronomical survey project ever undertaken. The survey will map in detail one-quarter of the entire sky, determining the positions and absolute brightnesses of more than 100 million celestial objects. It will also measure the distances to more than a million galaxies and quasars. Apache Point Observatory, site of the SDSS telescopes, is operated by the Astrophysical Research Consortium (ARC).

The SDSS addresses fascinating, fundamental questions about the universe. With the survey, astronomers will be able to see the large-scale patterns of galactic sheets and voids in the universe. Scientists have varying ideas about the evolution of the universe, and different patterns of large-scale structure point to different theories of how the universe evolved. The Sloan Digital Sky Survey will tell us which theories are right – or whether we have to come up with entirely new ideas.

The Sloan Digital Sky Survey (SDSS) is a joint project of The University of Chicago, Fermilab, the Institute for Advanced Study, the Japan Participation Group, The Johns Hopkins University, the Los Alamos National Laboratory, the Max-Planck-Institute for Astronomy (MPIA), the Max-Planck-Institute for Astrophysics (MPA), New Mexico State University, University of Pittsburgh, Princeton University, the United States Naval Observatory, and the University of Washington.

Funding for the project has been provided by the Alfred P. Sloan Foundation, the participating institutions, the National Aeronautics and Space Administration, the National Science Foundation, the U.S. Department of Energy, the Japanese Monbukagakusho, and the Max Planck Society.⁴²¹

⁴²¹ Taken from website www.sds.org. A picture of the latest galaxy-mapping showing Earth in the center of over 65,000 galaxies appears at: www.sdss.org/news/releases/galaxy_zoom.jpg

So what has this ambitious project found? Precisely the same thing that the previous studies have found – that Earth is in the center of all the galaxies and quasars mapped in the known universe. The pictorial provided by SDSS shows Earth in the center of two wedge-shaped galaxy segments that also show galaxy density decreases as the distance from Earth increases. Only from the vantage point of Earth do these stunning proportions become significant. In other words, if one were to view them from another part of the universe the concentric proportions would not appear. The centrality of Earth provided by the Sloan Digital Survey is thus consistent with the quantization of redshift values that have been accumulated for four decades prior. Once again, the “Copernican Principle” is violated. The evidence shows that Earth is the hub of the universe.

A Few Words about the Discover of the CMB

The Cosmic Microwave Background Radiation (CMB) is radiation in the form of microwaves (the same as are produced in a microwave oven) which has been found to pervade all of outer space. The wavelength of the microwaves is 7.3 centimeters, and the temperature is just slightly above absolute zero, registering at 2.728° Kelvin (approximately -272° Celsius or -458° Fahrenheit). History attributes the discovery of the CMB to Arno Penzias and Robert Wilson, who, in 1964, while seeking to eliminate all background interference from their radio receivers, were amazed to find one source that could not be eliminated. Contrary to popular belief, however, Penzias and Wilson were not the first to discover the CMB, although they received the Nobel Prize for its discovery in 1978.⁴²² The first radio astronomer to discover the CMB was Grote Reber (d. 2002) in the early 1940s, and his findings were widely known in many peer-reviewed journals.⁴²³ Around the same time (1941), Canadian astronomer Andrew McKellar discovered interstellar gas radiating at 3° Kelvin. Penzias and Wilson received credit for the discovery simply because, after receiving advice from astronomer Robert Dicke of Princeton, they interpreted the CMB in line with the burgeoning field of Big Bang cosmology initiated in the 1930s that claimed the universe came into being by a primordial explosion 10-20 billion years ago. In a way, it might be said that Penzias' and Wilson's aspirations went from the Big Doo-Doo to the Big Bang since, before they consulted with Dicke, they guessed that one possible cause for the interference was due to bird droppings,⁴²⁴ but many people still think it is a Big Doo-Doo, nonetheless.⁴²⁵

One of the main theses of the Big Bang theory is that the 2.728°K temperature is the result of radiation released in the reaction of electrons

⁴²² Arno A. Penzias and Robert W. Wilson, *Astrophysical Journal* 142: 419-427 (1965).

⁴²³ Some of Reber's work in this area includes the following: "Cosmic Static at 144 meters wavelength," *Journal of the Franklin Institute*, vol. 285 (Jan. 1968), pp. 1-12; "Cosmic Static," *Proc. IRE*, 28, 68 (1940); "Cosmic Static," *Astrophysical Journal*, 91, (1940) p. 621; "Cosmic Static," *Proc. IRE*, 30, 367 (1942); "Cosmic Static," *Astrophysical Journal*, 100, 279 (1944); "Cosmic Radio Noise," *Radio-Electronic Engineering*, July 1948; "Cosmic Static," *Proc. IRE*, 36, 1215, (1948); "Cosmic radio-frequency radiation near one megacycle," G. Reber and G. R. Ellis, *Journal of Geophysical Research*, 61, 1 (1956).

⁴²⁴ Karen Fox, *The Big Bang Theory – What It Is, Where It Came from and Why It Works*, New York: John Wiley and Sons, 2000, p. 78.

⁴²⁵ Eric Lerner, *The Big Bang Never Happened* (Vintage Books, 1992); William C. Mitchell, *Bye, Bye Big Bang: Hello Reality* (Common Sense Books, 2002). Fred Hoyle, et al., *A Different Approach to Cosmology*, England: Cambridge University Press, 2000. Tom van Flandern, *Dark Matter, Missing Planets and New Comets*, rev. ed. Berkeley: North Atlantic Books, 1993; "The Big Bang Brouhaha," *Nature*, 356:731, 1992.

and protons that were forming hydrogen about one million years after the primordial explosion. Since the temperature during this reactive state is said to have been 3,000°K, the resulting 2.278°K is said to be the result of a hydrogen flash redshift factor of $z = 1,000$, although few have an explanation why there were no objects in the cosmos with z factors between 10 and 1000. In any case, some time later Sir Fred Hoyle dubbed the theory “The Big Bang” in order to register his skepticism regarding its scientific validity, although Hoyle tenaciously held to an equally weak view called “The Steady State” theory, which holds that the universe is infinite yet comes into being bit by bit. Penzias and Wilson claimed the CMB was the remnant of the Big Bang, whereas Reber made it known he was vehemently against the Big Bang all the way to his death in 2002, and his work was consequently ignored.⁴²⁶

Dissidents from mainstream science are continuing to see the overwhelming problems with maintaining the Big Bang theory, although its adherents tenaciously hold on since they have few alternatives left. Every other cosmological theory (e.g., the “static” model, the “hesitation” models, the “steady state” model, the “oscillation” model), has been shown to contain devastating flaws. The Big Bang had one advantage that other models did not, however. It, indeed, predicted the existence of a residual radiation that would bath the universe, although their prediction was quite a bit higher than the present 2.728° Kelvin.⁴²⁷ Few dispute the clear fact that the CMB exists, but what is highly in dispute is precisely why it exists. C. E. Guillaume, proposing it to be 5° or 6° Kelvin, made estimates of the universe’s ambient temperature as early as 1896.⁴²⁸ In 1926 Sir Arthur Eddington posited that the space between the heated bodies of the universe would cool down to a temperature slightly above absolute zero, and his chosen figure was between 2.8° and 3.18° Kelvin.⁴²⁹ Seven years later, Erhard Regener

⁴²⁶ “Big bang creationism,” *Physics Today*, 35, p. 108, Nov. 1982; 1989: “Cosmic matter and the nonexpanding universe,” Paul Marmet, Grote Reber, *IEEE Trans. Plasma Science*, 17, no.2, 264 (1989); The Non-expanding universe: H. Reeves, *Journal of the Royal Astronomical Society*, 83, 223 (1989).

⁴²⁷ George Gamow is said to have predicted anywhere from 5° to 50° Kelvin in the late 1950s. *The Creation of the Universe*, New York: Viking Press, 1961. Van Flandern disputes this figure stating: “The Big Bang made no quantitative prediction that the ‘background’ radiation would have a temperature of 3 degrees Kelvin (in fact its initial prediction was 30 degrees Kelvin; whereas Eddington had already calculated that the ‘temperature of space’ produced by the radiation of starlight would be found to be 3 degrees Kelvin. And no element abundance prediction of the Big Bang was successful without some ad hoc parameterization to ‘adjust’ predictions that otherwise would have been judged as failures” (*Dark Matter, Missing Planets and New Comets*, rev. ed. Berkeley: North Atlantic Books, 1993), pp. 399-400.

⁴²⁸ C. E. Guillaume, *La Nature* 24, 2, 234, 1896.

⁴²⁹ Arthur S. Eddington, *The Internal Combustion of the Stars*, England: Cambridge University Press, 1926.

obtained the figure of 2.8° Kelvin, and stipulated that it was a homogeneous energy field.⁴³⁰ Nernst posited 0.75° Kelvin in 1938; Herzberg 2.3° Kelvin in 1941; Finlay-Freundlich, using the theory of “tired light” said it should be between 1.9° to 6° Kelvin. The reason these estimates are close is that a temperature of a few degrees above absolute zero is a reasonable natural minimum to expect in a universe said to be cooling down after a primordial explosion, considering that the temperature could not be absolute zero itself. In that case, however, there is little to persuade one that a Big Bang produces the CMB as opposed to merely the natural minimum of heat expected in a universe at equilibrium.

In actuality, it is precisely the equilibrium of the CMB that works against the Big Bang theory, for the Big Bang’s inventors predicted just the opposite. All cosmologists agree that the universe would be able to form its “lumpiness” (e.g. the masses of stars, planets, clusters, galaxies, quasars, etc.) only if the CMB registers some significant variation in its temperature. To date, no significant variation has been found, although the world’s scientists have been searching for it very intensely for over 50 years. One of the most sensitive instruments built to find a variation, NASA’s COBE satellite, initiated its measurements beginning in 1989 but it found a persistent smoothness in the CMB and its results were accurate to within 1 in 100,000.

⁴³⁰ Erhard Regener, *Zeitschrift für Physik*, 106:633-661, 1933.

Even apart from these, men could fall at a single breath
when pursued by justice and scattered by the breath of
thy power. But thou hast arranged all things by measure
and number and weight.

For it is always in thy power to show great strength, and
who can withstand the might of thy arm?

Because the whole world before thee is like a speck that
tips the scales, and like a drop of morning dew that falls
upon the ground.

Wisdom 11:20-22

"The trouble ain't that people are ignorant, it's just that they know so much that ain't so."

Josh Billings⁴³¹

"Perhaps it is time for astronomers to pause and wonder whether they know too much and understand too little."

Herbert Friedman⁴³²

"I know that most men...can seldom accept even the simplest and most obvious truth if it be such as would oblige them to admit the falsity of conclusions which they have delighted in explaining to colleagues, which they have proudly taught to others, and which they have woven, thread by thread, into the fabric of their lives."

Leo Tolstoy⁴³³

⁴³¹ "Josh Billings" was the pen name of American humorist Henry Wheeler Shaw (d. 1885).

⁴³² *The Amazing Universe*, National Geographic Society, 1975, p. 180.

⁴³³ Attributed.

Chapter 4

Answering Common Objections

In this chapter we will address some of the more common objections that are often raised against geocentrism, as well as demonstrate that the purported proofs of heliocentrism are invalid. We address these objections at this early stage of the book so that the reader can have an open mind when reading the rest of the book, as well as resolve any latent prejudices he may have formed in his mind from a lifelong advocacy of the heliocentric model. In answering these issues, however, we will do so only in a preliminary manner in this present chapter. The remaining details will be addressed more comprehensively in later chapters.

Doesn't the Smaller Body Revolve Around the Larger?

One of the more common objections to geocentrism is the claim that [Isaac Newton's](#) laws of motion prove that the Earth, because it is smaller, must revolve around the sun, which is larger. In reality, Newton proved no such thing. A close examination of his laws reveals that he merely stated, of two or more bodies in a rotating system, all bodies will revolve around the center of mass. As Newton himself put it: "That the center of the system of the world is immovable....This is acknowledged by all, although some contend that the Earth, others that the sun, is fixed in that center."⁴³⁴

Granted, in a closed system where the only two bodies existent are a massive sun and a small Earth, the center of mass will be much closer to the sun than the Earth, and thus, *in that system* the Earth would, indeed, revolve around the sun. But this is precisely the problem with the appeal to Newtonian mechanics: the appeal invariably limits the system to two bodies, the sun and the Earth, while it ignores the rest of the universe. When the rest of the universe is incorporated into the system, we now have a center of mass that is dependent on far more than the local forces we experience in our tiny solar system. On that basis, as we shall see, even Newton could not object to the Earth being the center of mass for the universe. The grand summation of his three laws of motion (namely, in a closed system the acceleration of the center of mass equals zero), will allow an immobile Earth to be the center, that is, if the universe is included in Newton's integral calculus. As the eminent

⁴³⁴ Isaac Newton, *Philosophiae Naturalis Principia Mathematica*, Book 3, "The System of the World," Proposition X. In Proposition XI Newton adds: "That the common center of gravity of the Earth, the sun, and all the planets, is immovable. For that center either is at rest or moves uniformly forwards in a right line; but if that center moved, the center of the world would move also, against the Hypothesis."

cosmologist [Fred Hoyle](#) admitted about those who quickly run to Newton to defend heliocentrism:

Although in the nineteenth century this argument was believed to be a satisfactory justification of the heliocentric theory, one found causes for disquiet if one looked into it a little more carefully. When we seek to improve on the accuracy of calculation by including mutual gravitational interactions between planets, we find – again in order to calculate correctly – that the center of the solar system must be placed at an abstract point known as the “center of mass,” which is displaced quite appreciably from the center of the Sun. And if we imagine a star to pass moderately close to the solar system, in order to calculate the perturbing effect correctly, again using the inverse-square rule, it could be essential to use a “center of mass” which included the star. The “center” in this case would lie even farther away from the center of the Sun. It appears, then, that the “center” to be used for any set of bodies depends on the way in which the local system is considered to be isolated from the universe as a whole. If a new body is added to the set from outside, or if a body is taken away, the “center” changes.⁴³⁵

As we can see from Hoyle’s account, even if there is only one star to take into account, its mass and gravitational force must be added into the formula for determining the universe’s center of mass (or barycenter). In short, our sun, Earth and planets are not an isolated system. Advocates of heliocentrism can mount no opposition to this logic since they believe that our solar system is revolving around the Milky Way, which, of course, it cannot do unless it is experiencing a strong gravitational attraction from the center of the Milky Way. Using that same principle, when we add to our galaxy the billions of other galaxies present in the universe, we can certainly conclude that they will have a substantial effect on determining the universe’s barycenter. As all modern physicists agree (even if they don’t prefer the geocentric model): “Mass there governs inertia here.”⁴³⁶ These distinguished authors are referring to the total mass of the galaxies and other objects in the universe that have a direct effect on the inertia we experience on Earth. Inertia is a force, and therefore, according to modern physics, the stars transmit an inertial force to the Earth. Moreover, modern physics also says that inertial force is intimately related and indistinguishable from gravitational force. If that is the case, then certainly the total mass of the universe is an integral factor in determining both the inertial and gravitational forces that affect the Earth, as well as the forces that create

⁴³⁵ Fred Hoyle, *Nicolaus Copernicus*, New York: Harper and Row, 1973, p. 85.

⁴³⁶ Misner, Charles W., Kip S. Thorne and John A. Wheeler, *Gravitation*, New York, W. H. Freeman and Co., 1973, pp. 543, 546-47, 549.

the barycenter of the universe. Certainly no one can object, then, if God had decided long ago to put the Earth in that very barycenter.

Doesn't Stellar Parallax Prove Heliocentrism?

Historically speaking, if we could point to one cosmological phenomenon that has been consistently advocated as the vindicator of heliocentrism, it is stellar parallax. Science books by the hundreds have declared that [Frederich Bessel](#) finally discovered heliocentrism's long-awaited proof when in 1838 he observed a slight shift in the position of a nearby star (Cygnus) against the background of a more distant star. Copernican astronomers continue to praise Bessel, but invariably they do so without either the slightest indication that parallax does not prove heliocentrism, or any admission that there is a perfectly good alternative which allows one to interpret parallax from a geocentric perspective.

To understand how parallax is formed, place a finger from your right hand at arms length and align it with a finger from your left hand at half an arm's length, both in front of your face. Observe your fingers first with your right eye open, and then with your left eye open. As you switch your vision from one eye to the other, the nearer finger will appear to shift to the right.

In the heliocentric system, parallax is said to occur when, on one side of the Earth's orbit, say January 1, two stars are viewed at the same time in a telescope, one star near us and the other star far away (at least by conventional means to measure star distances). Let's say that the two stars we view on January 1 are aligned vertically in the same plane, that is, one star is at a higher position in our telescope lens than the other but both are on the same vertical line. Six months passes and we look at the same two stars on June 1. If parallax is demonstrated, we will see that the stars are not in a vertical alignment any longer. Assuming the Earth has orbited in a counterclockwise direction, the nearer star appears to have shifted to the right. This is due to the fact that, in the interval of six months, one has looked at the two stars from two separate locations that are 185 million miles apart (the diameter of the Earth's orbit). Since stellar parallax can now be detected among a select few stars, most astronomers predisposed to accepting the Copernican worldview interpret the phenomenon as proof for the Earth's movement around the sun.

What most people don't know (and what most scientists keep from them) is that in the geocentric system the same optical phenomenon can be demonstrated. In the geocentric system, the stars are centered on the sun, (which is also true in the heliocentric system). The only difference, of course, is that in the geocentric system the Earth is fixed in space while *both* the sun and stars revolve around the Earth. Once again, on January 1, the two stars from our above example are in vertical alignment. When we look at these same two stars again on June 1, the nearer star will appear to have shifted to the right of the farther star, and it will do so at the same precise angle as in the heliocentric model. The same effect would occur, for example, if you stood near the non-rotating

center of a merry-go-round and observed the horses rotating around you. As the merry-go-round rotates, the nearer horse to you would appear to shift its position when compared to the horse farther away. In this example, the horses represent the stars, while the center of the merry-go-round represents the sun, and you are the observer on Earth. A more reliable way to see this effect is to view the animation of stellar parallax we have supplied with the compact disc.

The equivalence of **geocentric parallax** and **heliocentric parallax** is nothing out of the ordinary. Based on geometrical reciprocity, the two systems must be equal on all counts. The only difference is that in the heliocentric model the Earth is moving and the stars are fixed, while in the geocentric model the Earth is fixed and the stars are moving. Everything else is exactly the same. What *is* out of the ordinary, however, is that the natural equivalence between the two systems has been systematically suppressed out of virtually every science book written since the days of Newton, yet it is as simple and natural as the symmetry between one's right hand and left hand. Simply put, parallax does not prove heliocentrism. Rather, history shows that the phenomenon of parallax only proves there has been a rush to judgment in favor of heliocentrism that was based on nothing more than preference, not scientific fact.

One stumbling block toward understanding the equivalence between the heliocentric and geocentric concepts of parallax is that the **original model** of geocentrism advocated by **Tycho Brahe** did not have the stars centered on the sun; they were centered on the Earth. That being the case, no parallax would be forthcoming, at least based on the above mechanics and geometric proportions. That is, the stars would be in the same vertical alignment when one looked at them six months apart. Perhaps no one in Bessel's day (circa 1838) realized that the only thing required to bring the geocentric model into conformity with the results of heliocentric model was to shift the center of the stars from the Earth to the sun. Consequently, the geocentric model that had the stars centered on the sun never gained its rightful place in the halls of astronomy. Tycho Brahe had not presented such a model because in his day (1546-1601) no one had yet discovered a stellar parallax (laying aside the claims of Giovanni Pieroni cited earlier), and, in fact, this lacuna in the astronomical evidence was one of the arguments Tycho used to discredit heliocentrism. As it stands now, however, unless some astronomical proof is forthcoming that demonstrates that the stars are not centered on the sun (which is virtually impossible to do based on observation), then geocentrism has the same mechanical answer to the phenomenon of parallax as the heliocentric model. All that is needed is a slight modification to the original Tychonic model, which most geocentrists know as the modified Tychonic or neo-Tychonic model.

The neo-Tychonic model has been known to modern astronomy for quite some time and is still mentioned in some circles. For example,

at the department of physics at the University of Illinois, one class lecture states:

It is often said that Tycho's model implies the absence of parallax, and that Copernicus' requires parallax. However, it would not be a major conceptual change to have the stars orbit the sun (like the planets) for Tycho, which would give the same yearly shifts in their apparent positions as parallax gives. Thus if parallax were observed, a flexible Tychonean could adjust the theory to account for it, without undue complexity. What if parallax were not observed? For Copernicus, one only requires that the stars be far enough away for the parallax to be unmeasurable. Therefore the presence or absence of parallax doesn't force the choice of one type of model over the other. If different stars were to show different amounts of parallax, that would rule out the possibility of them all being on one sphere, but still not really decide between Tycho and Copernicus.⁴³⁷

The same course material adds the following conclusion:

In fact, if we don't worry about the distant stars, these two models describe identical relative motions of all the objects in the solar system. So the role of observation is not as direct as you might have guessed. There is no bare observation that can distinguish whether Tycho (taken broadly) or Copernicus (taken broadly) is right.⁴³⁸

⁴³⁷ University of Illinois, Physics 319, Spring 2004, Lecture 03, p. 8. In the last few years the same explanation for parallax has been promoted by astronomer Gerardus Bouw. He has also coined the term "modified Tychonic model" (*Geocentricity*, Association for Biblical Astronomy, Cleveland, 1992, p. 232).

⁴³⁸ University of Illinois, Physics 319, Spring 2004, Lecture 03, p. 8.

Doesn't the Foucault Pendulum Prove the Earth is Rotating?

The Foucault pendulum is another in a long line of purported proofs for the Copernican system. All over the world museums and universities house a working replica of Foucault's pendulum, modeled after the original device that was invented by the French physicist, [Jean Foucault](#) in 1851. Like any pendulum, such as those in the typical grandfather clock, the main action is the back-and-forth motion of a bob that hangs from a wire or rope of some proportionate length. But, unlike a grandfather clock that anchors the pendulum in one plane, the [Foucault pendulum](#) allows the anchor to rotate. That being the case, the plane of the pendulum will rotate over a given period of time. For example, if the pendulum begins its swing back-and-forth between the 12 o'clock and 6 o'clock position of the platform, within an hour or so, the pendulum will have moved to swinging between the 1 o'clock and the 7 o'clock position. Within an extended length of time (12 hours and 24 hours or longer), the pendulum will once again be swinging between the 12 o'clock and 6 o'clock position.

At different latitudes, however, there are different effects on the pendulum. At the North Pole the plane of the pendulum will rotate a full 360 degrees each 24-hours, or about 15 degrees per hour. As one moves farther from the North Pole in a southerly direction, the pendulum will slow down its rotation. In Washington DC, for example, instead of rotating 15 degrees in one hour, it moves about 9 degrees. At the equator there is no rotation of the pendulum. Below the equator the rotation begins again, but in the opposite direction (which is similar to the fact that weather systems rotate counterclockwise in the northern hemisphere and clockwise in the southern hemisphere, at least most of the time).

From the above description, one can imagine why many who were looking for proof of a rotating Earth would appeal to the Foucault pendulum. It seems logical to posit that the reason the plane of the pendulum appears to be moving in a circle is that the Earth beneath it is rotating. In other words, the heliocentrist insists that the pendulum's circular motion is an illusion. The pendulum is actually moving back-and-forth in the *same plane* and the Earth is turning beneath it. Since the Earth is too big for us to sense its rotation, we instead observe the plane of the pendulum rotate. All one need do to prove the Earth is rotating, he insists, is to reverse the roles, that is, imagine the plane of the pendulum is stationary and the Earth beneath it is moving.

This particular logic, however, doesn't prove that the Earth is rotating. One can begin the critique by asking this simple question: if the pendulum is constantly swinging in the same plane (while the Earth is rotating beneath it), what force is holding the pendulum in that stationary position? In other words, if the plane of the pendulum is stationary, with respect to what is it stationary? This is understood as an "unresolved" force in physics. The only possible answer is: it is stationary with respect

to the rest of the universe, since it is certainly not stationary with respect to the Earth. With a little insight one can see that this brings us right back to the problem that Einstein and the rest of modern physics faced with the advent of Relativity theory: is it the Earth that is rotating under fixed stars, or do the stars revolve around a fixed Earth? As Einstein said: “The two sentences: ‘the sun is at rest and the Earth moves,’ or ‘the sun moves and the Earth is at rest,’ would simply mean two different conventions concerning two different coordinate systems.”⁴³⁹ As such, it would be just as logical, not to mention scientifically consistent, to posit that the combined forces of the universe which rotate around the Earth are causing the plane of the pendulum to rotate around an immobile Earth. In other words, in the geocentric model the movement of the pendulum is not an illusion – it really moves. According to Einstein, there is no difference between the two models. Ernst Mach, from whom Einstein developed many of his insights, stated much the same. He writes:

Obviously, it doesn't matter if we think of the Earth as turning round on its axis, or at rest while the fixed stars revolve round it. Geometrically these are exactly the same case of a relative rotation of the Earth and the fixed stars with respect to one another. But if we think of the Earth at rest and the fixed stars revolving round it, there is no flattening of the Earth, no Foucault's experiment, and so on...⁴⁴⁰

Hence, the Foucault pendulum offers no proof for heliocentrism; rather, it only proves how presumptuous modern science has been for the last few hundred years. The same goes for the appeal to the Coriolis force or the oblateness of the Earth as proofs of the Earth's rotation. The only fact these particular phenomena prove is that there is a force causing their effect, not that a rotation of the Earth is the force.

⁴³⁹ *The Evolution of Physics: From Early Concepts to Relativity and Quanta*, Albert Einstein and Leopold Infeld, New York, Simon and Schuster, 1938, 1966, p. 212.

⁴⁴⁰ As cited in William G. V. Rosser's, *An Introduction to the Theory of Relativity*, London, Butterworths, 1964, p. 454, citing Dennis Sciama's, *The Unity of the Universe*, New York, Anchor Books, 1959.

Doesn't Retrograde Motion Prove Heliocentrism?

Retrograde motion occurs when a planet that has been traversing the night sky in one direction for several months suddenly reverses its direction for a few weeks, and a few weeks later reverses its direction again, heading back in the same direction it had originally been traveling. In simpler terms, the planet makes a loop in its path over the course of several weeks against the background of fixed stars. In principle, each of the eight planets, as viewed from Earth, will present a retrograde motion, although some planets, due to their close proximity to Earth, will have more pronounced retrogrades. This is true of Venus and Mars, the latter's path being the most eccentric among the planets.

Since in the heliocentric system the Earth travels faster in its orbit than Mars, at some point Mars, as viewed from Earth, will appear to go backward during the time Earth is making its closest approach to Mars. Various astronomical texts and other science publications have consistently appealed to this phenomenon as a proof for heliocentrism. Science textbooks illustrate the occurrence with elaborate diagrams while websites have sophisticated java script animations, both pretending as if only the heliocentric model has an explanation for retrograde motion. Rarely will the author educate the student to the fact that both the Ptolemaic and the Tyconic models answer the phenomenon of retrograde motion just as well as the Copernican model. If the author dares to mention something other than the Copernican model, it is usually with an air of superiority, as if the other models are somehow giving us a mere illusion of working correctly. The truth is, however, since the Copernican, the Ptolemaic, and the Tyconian models incorporate the same geometrical distances between the planets and the sun, then both, in principle, account for retrograde motion, and they will do so in identical proportions. This is no secret to the well-informed, but many a naïve student has been influenced to the contrary by those wishing to advance Copernican cosmology.

In addition to the animations depicting the equality of the [Copernican](#) and [Tyconic](#) models of retrograde motion, the same animations can be created to show the equality of the Copernican and Ptolemaic models. In an exhibition that opened in December 1972, Charles Eames demonstrated that both systems are identical. As astrophysicist Owen Gingerich describes it:

The Eames machine ran continually without default for something like sixth months. As the circles turned, [the rods](#), representing the observed line of sight to Mars, always remained parallel. Each time Mars came on the inner side of the epicycle, the combined counterclockwise motions of the deferent and epicycle caused the geocentric rod to briefly swing clockwise, the so-called

retrograde motion. Whenever that happened, in the heliocentric model the faster-moving Earth was always nearest Mars and bypassing it, so the heliocentric rod remained in perfect tandem with the geocentric rod. It was a brilliant demonstration of the equivalence of the two systems, and what worked for Mars would work for each of the other planets.⁴⁴¹

⁴⁴¹ Owen Gingerich, *The Book that Nobody Read*, pp. 44-45.

Doesn't NASA Use the Heliocentric System for its Space Probes and Satellites?

In reality, NASA will use whatever system is more convenient, the heliocentric or the geocentric, since NASA's orbital mechanics know that both models are equivalent, mathematically and geometrically. If they are sending probes near the sun, they will probably use a heliocentric model, since it is easier to make calculations when one considers the sun as fixed in space with the planets moving around it. If they are sending up satellites near the Earth, however, they will use a geocentric model, or what is known in the industry as a "fixed-Earth coordinate system." This is because it is much easier to calculate and chart the movements of satellites circling the Earth if the Earth is understood as stationary in space. This fact is easily proven from the space agency's own documentation. For example, in a letter written to the *National Oceanic and Atmospheric Administration* (NOAA) making the following inquiry: "Is the present movement of GOES [Geostationary Satellite] planned and executed on the basis of a fixed earth or a rotating earth?" the answer returned by the department head of GOES/POLAR Navigation, Office of Satellite Operations at the NOAA was very simple: "Fixed earth."⁴⁴²

At other times, NASA tries to give the impression to a gullible public that only the heliocentric model will work. Through email correspondence in October 2005, NASA representatives personally invited this author to their on-line *Question and Answer* forum.⁴⁴³ A few weeks prior to the invitation, the same NASA representatives had answered a question on their forum from another person regarding whether NASA's probes could be sent into space and tracked using the geocentric system rather than the heliocentric. The NASA representatives answered in the negative, stating: "If the universe were geocentric, all of our calculations for space probe trajectories would be wrong." The person who asked the question then sent NASA's answer to this author as proof for the heliocentric system. Accepting NASA's invitation, I then sent a formal question to the NASA website asking them to show proof why a geocentric system would not work. After six weeks of not receiving an answer, I contacted the representatives by

⁴⁴² The original letter was addressed to Charles E. Liddick of the United States Department of Commerce, Office of Satellite Operations, Washington, DC 20233 on November 17, 1989. Mr. Liddick transferred the inquiry to Lee Ranne, from GOES/POLAR Navigation, Office of Satellite Operations at the NOAA offices in the department of National Environmental Satellite Data and Information Service, who then wrote to, the questioner, Marshall Hall, on November 22, 1989, with a copy to Mr. Liddick. Original letters are cited in Marshall Hall's *The Earth is Not Moving*, Cornelia, Georgia, Fair Education Foundation, 1994, p. 261.

⁴⁴³ (http://imagine.gsfc.nasa.gov/docs/ask_astro/ask_an_astronomer.html).

private email and asked if they were planning to answer the question. They wrote back to me and stated that they did not plan to answer it. After I tried to convince them that, since in this public forum they had, by their initial assertions against geocentric navigation, already committed themselves, and thus had an obligation to the public to defend their position, they still refused to answer. As a rejoinder, I told them that I would be including the entire communication between them and myself in this present book. The NASA representatives then demanded that their names be withheld, stating:

We do not give you permission to quote us or use our names in your book or on your website. Although we work at NASA centers, we are not NASA employees and for us to be presented in your work as official representatives of NASA would be inappropriate and misleading.

I have obliged their request, except to quote the above paragraph. My suggestion to them was the following:

As for whether you work for NASA or not, the website has a nasa.gov address. So if you're not affiliated with NASA then I suggest you find a different website address, since otherwise, you are misleading the public. Of course, we can avoid all this extracurricular activity if you, as an astrophysicist, would tell us why a geocentric system would not work. The ball is in your court.

To this day there has been no response from them. As one can see quite readily from the above exchanges, although one government agency, at least in a private letter, was willing to divulge the truth about the use of fixed-Earth mechanics, another agency refused to be as forthcoming when the audience included the millions of potential readers on the Internet. This is really no surprise to us. Those who control our space programs have a vested interest in keeping the public under the illusion of Copernicanism, since all their funding and projects are based on Copernicus' premises, including the quest to find life in other worlds. Only those who are courageous and knowledgeable enough can expose the illusion and allow the public to see the cosmic shell game that has been occurring for quite a long time. One such party is the team of Ruyong Wang and Ronald Hatch, two former government satellite engineers who know the truth about the illusion. In one of their investigations on the Global Positioning System they write:

...NavCom Technology, Inc. has licensed software developed by the Jet Propulsion Lab (JPL) which, because of historical reasons, does the entire computation in the ECI frame. Because of some discrepancies between our standard earth-centered earth-fixed solution results and the JPL results, we investigated

the input parameters to the solution very carefully. The measured and theoretical ranges computed in the two different frames agreed precisely, indicating that the Sagnac correction had been applied in each frame.

As the discussion of the Sagnac effect indicates the fundamental question regarding the speed of light is the following: Is the speed of light constant with respect to the observer (receiver) or is it constant with respect to the chosen inertial ECI frame? Clearly the GPS range equation indicates the speed of light is constant with respect to the chosen frame...The JPL equations, used to track signals from interplanetary space probes, verify that the speed of light is with respect to the chosen frame. In the JPL equations, the chosen frame is the solar system barycentric frame....Clearly, the JPL equations treat the speed of light as constant with respect to the frame – not as constant with respect to the receivers.⁴⁴⁴

In other words, the Jet Propulsion Laboratory (JPL) employs the Earth Centered Inertial frame (ECI) for probes sent out near the Earth (as does NASA and the GPS), yet the Jet Propulsion Lab claims to use the “solar system barycentric frame” for deep space navigation. Wang and Hatch tell us, however, “the Jet Propulsion Lab...because of historical reasons, does the entire computation in the ECI frame.” Not only does the Jet Propulsion Lab use the ECI frame exclusively, Wang and Hatch tell us that the Lab corrects the calculations in its “solar system barycentric frame” so that they match the ECI frame! We can see clearly that the Earth-centered frame is the standard, and thus, use of the ‘solar system barycentric frame’ is superfluous. Once the Lab’s computer makes the corrections to the solar system barycentric frame, in reality the deep space navigation is actually using the ECI frame – a fixed Earth. The public wouldn’t have been made privy to this sleight-of-hand manipulation except for the fact that two knowledgeable insiders, Wang and Hatch, have told the real story. In effect, the Earth Centered Inertial frame (e.g., geocentrism) is the only frame that allows the GPS and various space probes to work properly. The significance of these facts will be highlighted when we deal with the Sagnac Effect in Chapter 6, and the Global Positioning Satellites in Appendix 7.

⁴⁴⁴ Ruyong Wang and Ronald R. Hatch, *Conducting a Crucial Experiment of the Constancy of the Speed of Light Using GPS*, ION GPS 58th Annual Meeting / CIGTF 21st Guidance Test Symposium, 2002, p. 500.

Don't the Phases of Venus Disprove Ptolemy's Geocentrism?

One of the more popular arguments offered against the geocentric system is the charge that Ptolemy's model could not account for the phases of Venus. Galileo used this very argument against the geocentrists of his day. Since that time, few have examined Galileo's claims with any respectable amount of scrutiny. The issue is a bit more complicated than meets the eye. Even those who see the merits of geocentrism, stumble over the phases of Venus. For example, although scientific writer Kitty Ferguson concedes, on the one hand, that: "...Einstein's theories reveal they may actually slightly favor an Earth-centered model,"⁴⁴⁵ and that the only advantage of Copernican theory is it "is more easily falsifiable than Ptolemy's," on the other hand she perpetuates the misleading conclusion that Ptolemy could not account for Venus' phases. As she compares and comments on her own diagrams of Ptolemy and Copernicus' models, she concludes:

It was this line of reasoning that Galileo used in 1610, when he studied the planet Venus through his telescope....In the Ptolemaic system, with Venus always between the Earth and the Sun – traveling on an epicycle on a deferent with the Earth as its center – an observer on Earth would never see the face of Venus anywhere near fully illuminated.⁴⁴⁶

Similarly, Andrew White, in his classic, *A History of the Warfare of Science with Theology in Christendom*, employs his usual sardonic style to make the same point:

Ten years after the martyrdom of Bruno the truth of Copernicus's doctrine was established by the telescope of Galileo. Herein was fulfilled one of the most touching of prophecies. Years before the opponents of Copernicus had said to him, 'If your doctrines were true, Venus would show phases like the moon.' Copernicus answered: 'You are right; I know not what to say; but God is good, and will in time find an answer to this objection.' The God-given answer came when, in 1611, the rude telescope of Galileo showed the phases of Venus.⁴⁴⁷

Although certain versions of Ptolemy's system seem to demonstrate its inability to account for Venus' phases, the truth is that these versions no more deny the basic model of Ptolemaic geocentrism

⁴⁴⁵ *Measuring the Universe*, New York, Walker and Company, 1999, p. 106.

⁴⁴⁶ *Measuring the Universe*, New York, Walker and Company, 1999, pp. 92-93.

⁴⁴⁷ Andrew White, *A History of the Warfare of Science with Theology in Christendom*, New York, Appleton, 1907, p. 130.

than the errors in Copernicus' original model (which were based on circles and epicycles) would discount heliocentrism prior to Kepler's corrections by means of ellipses. Upon close inspection of Ferguson's diagrams, we can understand why so many people have been unduly convinced that Ptolemy's model was lacking. First, virtually all of the textbook diagrams of Ptolemy's model are not drawn to scale. Although Ferguson is kind enough to alert her reader that: "The distances and size of orbits in this drawing do not reflect the actual distances and orbits,"⁴⁴⁸ she fails to acknowledge that without accurate scales the diagrams prove nothing, except perhaps a bias against Ptolemy. Ptolemy, of course, had the same problem, but it was inadvertent. He did not know the actual distances to the sun, the planets or the moon, and consequently his diagrams are never drawn to scale, and thus Venus might never show the proper phases in his charts.

Using the same logic, modern heliocentrists often accuse Ptolemy of having the moon come too close to the Earth, and thereby appeal to this lopsided orbit as convincing evidence to discredit his system. For example, Stephen Hawking asserts the following:

Ptolemy's model provided a fairly accurate system for predicting the positions of heavenly bodies in the sky. But in order to predict these positions correctly, Ptolemy had to make an assumption that the moon followed a path that sometimes brought it twice as close to the earth as at other times. And that meant that the moon ought sometimes to appear twice as big as at other times! Ptolemy recognized this flaw, but nevertheless his model was generally, although not universally accepted. It was adopted by the Christian church as the picture of the universe that was in accordance with scripture, for it had the great advantage that it left lots of room outside the sphere of fixed stars for heaven and hell.⁴⁴⁹

Hawking makes his claim, of course, without noting that Ptolemy's model was neither drawn to scale nor was ever adjusted for errors, in addition to implying that the Catholic Church knew of Ptolemy's alleged error yet had an ulterior motive for insisting that his model be preserved. The fault, of course, lies in Hawking's failure to see that if Ptolemy's model had been drawn to scale and its epicycles adjusted, the correct distance to the moon could have been accommodated.

As we noted previously, before Kepler's improvements to the heliocentric model, Copernicus' system was no more accurate than

⁴⁴⁸ *Measuring the Universe*, p. 93.

⁴⁴⁹ Stephen Hawking and Leonard Mlodinow, *A Briefer History of Time*, New York, Bantam Dell, 2005, pp. 9-10.

Ptolemy's, despite the fact that Copernicus used more epicycles than Ptolemy. As Copernicus' model was improved, so were the results of calculations to track the orbits of the planets. Yet the same kind of corrections could have been made to the Ptolemaic model to improve its accuracy, including corrections to account for the phases of Venus. The model itself did not have to be scraped. The distance to the moon and the phases of Venus could have been made as prominent and precise as they appear in the improved Keplerian model if, instead of Ptolemy's circles: (a) the planetary orbits are made into elliptical paths around the sun,⁴⁵⁰ or: (b) the sun's orbit around the Earth is made a deferent and the epicycle's radius is made equal to the actual scalar distance between the sun and planet, or: (c) the sun's motion is placed in one epicycle and the planets' epicycles are centered on the sun, or: (d) the Earth is lined up with respect to the stars rather than with respect to the sun. All four solutions would make the paths cycloidal with respect to the Earth, and all will account for the phases of Venus. Option (c) is essentially the model proposed by Tycho Brahe. As astronomer Gerardus Bouw notes:

Even astronomers and historians who should know better claim that Galileo's discovery that Venus exhibits moon-like phases disproved the Ptolemaic model. All that Galileo's observations actually meant insofar as the Ptolemaic model was concerned, was that the radii of the epicycles were much larger than had previously been suspected; and all that Kepler's elliptical orbits meant to the Ptolemaic model was that two of the epicycles could be combined into one ellipse.⁴⁵¹

As it stands, there was a lot of room to make adjustments to Ptolemy's model to fit the observations, but no one was willing to do so once Copernicus' system was seized and promoted by the Renaissance and Enlightenment as a means to demote the authority of Scripture and take control away from the Catholic Church to influence the minds of men. As astronomer Ivan King understood it:

⁴⁵⁰ Applying elliptical orbits to his model might have been something Ptolemy himself once contemplated. As Koestler notes: "A glance at the orbit of Mercury in the Ptolemaic system...shows a similar egg-shaped curve staring into one's face" (*The Sleepwalkers*, pp. 80-81). Others also saw the advantage of elliptical orbits for Ptolemy. In 1080, the Spanish-Muslim astronomer Al-Zarqali (aka Arzachel) became quite famous for his Toledan Tables, the forerunner of the Alfonsine Tables (published in 1252 A.D.), of planetary positions. Originally written in Arabic, only two Latin translations have survived. Along with his six astrolabes, the Toledan Tables reveal that Al-Zarqali was keenly aware of the improvements available to the Ptolemaic system by means of elliptical orbits, but at this time in history, deference to the perfect circle was simply too strong to be overcome.

⁴⁵¹ Gerardus Bouw, *Geocentricity*, Association for Biblical Astronomy, Cleveland, 1992, pp. 309-310.

In a single phrase, the God-centered outlook of the middle ages had been replaced by the man-centered outlook of the renaissance. The change had flowed over every aspect of human activity.⁴⁵²

⁴⁵² Ivan R. King, *The Universe Unfolding*, San Francisco, W. H. Freeman, 1976, p. 126.

Isn't it Impossible for the Stars to Travel so Fast?

Another common objection to placing the Earth in the center of our solar system is that it would also need to be in the center of the universe, and thus, it would be impossible for the stars, being so far away, to revolve around the Earth on a daily basis, since they would be required to travel faster than the speed of light to complete their daily trek. As with all the objections in this section, we will answer them in more detail in later chapters, but for now we can respond in two ways. First, even assuming for the sake of argument that geocentrism holds that the stars travel faster than light (which it does not); still, those who base their objections on the tenets of modern science have little room to mount criticism. As a popular scientist explains for the novice, in Relativity theory:

...it is permissible to assume that the Earth is a nonrotating frame of reference. From this point of view, the stars will have a circular velocity around the Earth that is much greater than the speed of light. A star only ten light-years away has a relative velocity around the Earth of twenty thousand times the speed of light.⁴⁵³

A more technical book on Relativity written for the scientist admits the same:

Relative to the stationary roundabout [the Earth], the distant stars would have...linear velocities exceeding 3×10^8 m/sec, the terrestrial value of the velocity of light. At first sight this appears to be a contradiction...that the velocities of all material bodies must be less than c [the speed of light]. However, the restriction $u < c = 3 \times 10^8$ m/sec is restricted to the theory of Special Relativity. According to the General theory, it is possible to choose local reference frames in which, over a limited volume of space, there is no gravitational field, and relative to such a reference frame the velocity of light is equal to c If gravitational fields are present the velocities of either material bodies or of light can assume *any numerical value* depending on the strength of the gravitational field. If one considers the rotating roundabout as being at rest, the centrifugal gravitational field assumes enormous values at large distances, and it is consistent with the theory of General Relativity for the velocities of distant bodies to exceed 3×10^8 m/sec under these conditions.⁴⁵⁴

⁴⁵³ Martin Gardner, *Relativity Explosion*, New York, Random House, 1976, p. 68.

⁴⁵⁴ *An Introduction to the Theory of Relativity*, William Geraint Vaughn Rosser, London, Butterworths, 1964, p. 460. W. G. V. Rosser, Ph.D. was the senior lecturer in Physics at Exeter University.

Einstein himself admitted this very principle:

In the second place our result shows that, according to the general theory of relativity, the law of the constancy of the velocity of light *in vacuo*, which constitutes one of the two fundamental assumptions in the special theory of relativity and to which we have already frequently referred, cannot claim any unlimited validity. A curvature or rays of light can only take place when the velocity of propagation of light varies with position. Now we might think that as a consequence of this, the special theory of relativity and with it the whole theory of relativity would be laid in the dust. But in reality this is not the case. We can only conclude that the special theory of relativity cannot claim an unlimited domain of validity; its results hold only so long as we are able to disregard the influences of gravitational fields on the phenomena (e.g., of light).⁴⁵⁵

Another important issue concerning the speed of light is precisely this question: what does modern physics mean when it says that something cannot exceed the speed of light? It's not what you might logically think. Normally we would interpret the light speed barrier as an inherent property of nature in which, all things being equal, a material object cannot reach the speed of light, since it would actually need to be light in order to travel as fast as light. But this is not how Relativity theory explains it. In a manner of speaking, modern scientists have determined that 'all things are not equal.' The 'inequality' was invented when science had a very difficult time explaining the result of the [1887 Michelson-Morley](#) experiment. As we noted briefly earlier (and will investigate in much more detail in later chapters), in order to provide modern science an escape from having to conclude that the Earth was motionless in space, various scientists explained the Michelson-Morley experiment by postulating that matter compresses when it moves. In this case, Michelson's instruments were said to register a "null" result for movement of the Earth through space because, due to the pressure generated by the assumed orbit of the Earth, the instruments shrank during the course of the experiment. Having no other way to prohibit the Earth from being motionless in space, most scientists succumbed to the "shrinking matter" hypothesis, and soon it became standard fare in the world of physics. Dubbed as either the "Fitzgerald contraction" and later made into an equation called the "Lorentz transformation," it was so readily accepted that it became the pat answer to every motion problem in physics, and among those answers was why no object could ever reach the speed of light. As physicist Arthur Eddington explains it:

⁴⁵⁵ Albert Einstein, *Relativity: The Special and the General Theory*, authorized translation by Robert W. Lawson, Three Rivers Press, New York, 1961, p. 85.

It is no use trying to overtake a flash of light; however fast you go it is always traveling away from you at 186,000 miles a second. Now from one point of view this is a rather unworthy deception that Nature has practiced upon us. Let us take our favourite observer who travels at 161,000 miles a second and send him in pursuit of the flash of light. It is going 25,000 miles a second faster than he is; but that is not what he will report. Owing to the contraction of his standard scale his miles are only half-miles; owing to the slowing down of his clocks his seconds are double-seconds. His measurement would therefore make the speed 100,000 miles a second (really half-miles per double-second). He makes a further mistake in synchronizing the clocks with which he records the velocity....This brings the speed up to 186,000 miles a second. From his own point of view the traveler is lagging hopelessly behind the light; he does not realize what a close race he is making of it, because his measuring appliances have been upset.⁴⁵⁶

So here we see that the “traveler” is, as Eddington admits, coming close to, and could possibly match, the speed of light, but because his instruments have shrunk and his clock moves slower due to his excessive speed, it will *only appear* as if it is impossible to catch the light beam. Welcome to the bizarre world of Relativity. On the stage is reality versus illusion, but by the very nature of its principles, Relativity is at a loss to tell us which part is reality and which part is illusion. Perhaps this is why Eddington had few qualms once referring to the Fitzgerald contraction as: “The shortening of the moving rod is *true*, but it is not *really true*.”⁴⁵⁷ Of course, we need to remind ourselves that the

⁴⁵⁶ Sir Arthur Eddington, *The Nature of the Physical World*, from the 1927 Gifford Lectures, New York, MacMillian Company, 1929, p. 54. All spellings of words in the quote are from Eddington’s British.

⁴⁵⁷ Arthur S. Eddington, *The Nature of the Physical World*, New York, MacMillian and Cambridge University Press, 1929, pp. 33-34, emphasis his. Opposed to Eddington, some Relativists believe: **(1)** “The contraction is real.” Møller writes: “Contraction is a real effect observable in principle by experiment... This means the concept of length has lost its absolute meaning” (Møller, *The Theory of Relativity*, 1972, p. 44); Wolfgang Pauli: “It therefore follows that the Lorentz contraction is not a property of a single rod taken by itself, but a reciprocal relation between two such rods moving relatively to each other, and this relation is in principle observable” (*The Theory of Relativity*, Dover Publications, 1958, pp. 12-13); R. C. Tolman: “Entirely real but symmetrical” (*Relativity Thermodynamics and Cosmology*, pp. 23-24). **(2)** “The contraction is not real.” E. F. Taylor and John Wheeler write: “Does something about a clock really change when it moves, resulting in the observed change in the tick rate? Absolutely not!” (*Spacetime Physics: Introduction to Special Relativity*, p. 76). **(3)** “The contraction is only apparent.” Aharoni writes: “The moving rod appears shorter. The moving clock appears to go slow” (*The Special Theory of Relativity*, p. 21); McCrea writes: “The apparent length is reduced. Time intervals appear to be lengthened; clocks appear to go slow” (*Relativity Physics*, pp. 15-16); Nunn: “A moving rod would appear

so-called ‘shrinking of the instruments’ and ‘slowing of the clock’ is all the result of the fallacious interpretation of the Michelson-Morley experiment, an interpretation that was forced upon the science establishment in order to keep the Earth from being motionless in space. To this very day, no scientist in the world has ever explained, let alone proven, the precise physical reason why matter should shrink in length when it moves, or how time can dilate in the process, yet they believe it nonetheless, for, as we will see later, it is their only defense against going back to pre-Copernican days.

We can also answer the objection by noting that, although it is to our advantage to use modern physics against itself as we do when we point out that General Relativity permits a body to move faster than the speed of light, the celestial mechanics of geocentrism, in fact, does not claim that the stars move faster than light. Geocentrism says only that the universe rotates around the Earth once per day, and in that rotation it carries the stars with it. Thus, compared to the universe within which they are contained, the stars are not moving at all, save for their minuscule independent movements.

Mechanically speaking, the rotation of the universe is an integral facet of the geocentric system so as to act as a counterbalance to the inward pressure of gravity. It just so happens that the centrifugal force created by a 24-hour rotation period prohibits the stars and other material in the universe from collapsing inward (a problem, incidentally, that Newton and Einstein recognized in their respective universes, which Newton attempted to answer by opting for an infinite universe, and Einstein by his infamous “cosmological constant,” neither of which provided an adequate solution). In addition, an advocate of Relativity can raise no objections against geocentrism’s rotating universe since Relativity sees no difference, or has no way to distinguish between, a

to be shortened” (*Relativity and Gravitation*, pp. 43-44); Whitrow: “Instead of assuming that there are real, i.e., structural changes in length and duration owing to motion, Einstein’s theory involves only apparent changes” (*The Natural Philosophy of Time*, p. 255). (4) “The contraction is the result of the relativity of simultaneity.” Bohn writes: “When measuring lengths and intervals, observers are not referring to the same events” (*The Special Theory of Relativity*, p. 59). See also William Rosser, *Introductory Relativity*, p. 37; and A. P. French, *Special Relativity*, p. 97; and Stephenson and Kilmister, *Special Relativity for Physicists*, pp. 38-39. (5) “The contraction is due to perspective effects.” Rindler writes: “Moving lengths are reduced, a kind of perspective effect. But of course nothing has happened to the rod itself. Nevertheless, contraction is no illusion, it is real” (*Introduction to Special Relativity*, p. 25). (6) “The contraction is mathematical.” Herman Minkowski writes: “This hypothesis sounds extremely fantastical, for the contraction is not to be looked upon as a consequence of resistances in the ether, or anything of that kind, but simply as a gift from above, – as an accompanying circumstance of the circumstance of motion” (“Space and Time,” in *The Principle of Relativity: A Collection of Original Memoirs on the Special and General Theory of Relativity* by H. A. Lorentz, A. Einstein, H. Minkowski and H. Weyl, translated by W. Perrett and G. B. Jeffery from the original 1923 edition, Dover Publications, 1952, p. 81).

rotating Earth among fixed stars or stars that revolve around a fixed Earth. The two are relativistically equivalent.

But Didn't Science Prove that Ether Doesn't Exist?

Although a little more esoteric to this debate, nevertheless, there is a common objection that often stems from Albert Einstein's interpretation of the [1887 Michelson-Morley](#) experiment. Since the Michelson-Morley experiment assumed the Earth was moving, yet their [apparatus](#) could not detect any such movement against what was then understood as "ether," Einstein concluded that ether did not exist, that is, space is empty; it is a vacuum that does not contain any substance at all. But most scientists today have rejected Einstein's view and have come to realize that space does, indeed, have substance, and one that reaches to the outer limits of the universe. The days of negating a scientific theory based on its belief in ether are over. As even the Relativist (and Nobel physics laureate) Robert B. Laughlin admits:

It is ironic that Einstein's most creative work, the general theory of relativity, should boil down to conceptualizing space as a medium when his original premise was that no such medium existed....Einstein...utterly rejected the idea of ether and inferred from its nonexistence that the equations of electromagnetism had to be relative. But this same thought process led in the end to the very ether he had first rejected, albeit one with some special properties that ordinary elastic matter does not have.

The word "ether" has extremely negative connotations in theoretical physics because of its past association with opposition to relativity. This is unfortunate because, stripped of these connotations, it rather nicely captures the way most physicists actually think about the vacuum. In the early days of relativity the conviction that light must be waves *of* something ran so strong that Einstein was widely dismissed. Even when Michelson and Morley demonstrated that the earth's orbital motion through the ether could not be detected, opponents argued that the earth must be dragging an envelope of ether along with it because relativity was lunacy and could not possibly be right....Relativity actually says nothing about the existence or nonexistence of matter pervading the universe, only that such matter must have relativistic symmetry.

And he concludes with this important paragraph:

It turns out that such matter exists. About the time relativity was becoming accepted, studies of radioactivity began showing that the empty vacuum of space had spectroscopic structure similar to that of ordinary quantum solids and fluids. Subsequent studies with large particle accelerators have now led us to understand that space is more like a piece of window glass than ideal Newtonian emptiness. It is filled with "stuff"

that is normally transparent but can be made visible by hitting it sufficiently hard to knock out a part. The modern concept of the vacuum of space, confirmed every day by experiment, is a relativistic ether. But we do not call it this because it is taboo.⁴⁵⁸

We cite Laughlin knowing full well that in his frequent use of the word “relativistic” he, nevertheless, believes the Earth revolves around the sun, and most likely has never given any particular consideration to a geocentric universe. In any case, his expertise is valuable for this debate since: (a) ether is a constituent part of the geocentric universe, and (b) despite Relativity’s initial rejection of ether, Laughlin is quite candid that Quantum Mechanics has sufficiently demonstrated ether’s existence to the once skeptical Einstein audience. Unfortunately, Laughlin is not so candid regarding the fact that Relativity and Quantum Mechanics are diametrically opposed to one another. We will cover the issue of ether, Relativity, and Quantum Mechanics in more detail in later chapters.

Even among Einstein’s supporters the understanding that space is filled with substance was never relinquished. [Louis de Broglie](#) (d. 1987), the Nobel laureate famous for his discovery of the electron’s wave in the 1920s, wrote in 1971 that the concept of ether, or as he calls it “the hidden medium,” needed to be revived. Critiquing the model of space proposed by [Erwin Schrödinger](#) in 1926, de Broglie longs for the days of fixed points reminiscent of Descartes’ Cartesian axes and Newton’s absolute space:

Everything becomes clear if the idea that particles always have a position in space through time is brought back....According to my current thinking, the particle is always located within a physical wave....The movement of the particle is assumed to be the superposition of a regular movement...and of a Brownian movement due to random energy exchanges which take place between the wave and a hidden medium, which acts as a subquantum thermostat. The point of prime importance in this model is that at each moment the particle occupies a well-defined position in space, and this re-establishes the clear meaning which the configuration space had in classical mechanics.⁴⁵⁹

⁴⁵⁸ Robert B. Laughlin, *A Different Universe: Reinventing Physics from the Bottom Down*, New York, Basic Books, 2005, pp. 120-121. The two chapters of Laughlin’s book that deal with these issues are: “The Nuclear Family,” (pp. 99-116 and “The Fabric of Space-Time” (pp. 117-126).

⁴⁵⁹ Louis de Broglie, “Waves and Particles,” *Physics Bulletin*, 22, February 1971, single page. In the same article he adds: “...whereas in my original concept I assumed that the coexistence of waves and particles, perceived by Einstein in 1905 in respect of light in his theory of light quanta, should be extended to all types of particle[s] in the form of the coexistence of a physical wave with a particle incorporated in it. Moreover, Schrödinger’s ψ wave was soon to lose the nature of a physical wave on the day when

Even Albert Einstein eventually succumbed to the need for some type of ether. In 1916 he wrote:

...in 1905 I was of the opinion that it was no longer allowed to speak about the ether in physics. This opinion, however, was too radical, as we will see later when we discuss the general theory of relativity. It does remain allowed, as always, to introduce a medium filling all space and to assume that the electromagnetic fields (and matter as well) are its states...once again “empty” space appears as endowed with physical properties, i.e., no longer as physically empty, as seemed to be the case according to special relativity. One can thus say that the ether is resurrected in the general theory of relativity...Since in the new theory, metric facts can no longer be separated from “true” physical facts, the concepts of “space” and “ether” merge together.⁴⁶⁰

Ludwik Kostro, whose book *Einstein and the Ether* has revealed the heretofore undisclosed history of ether science in the twentieth century, states the following candid conclusion:

Modern science has its roots in ancient Greek philosophy. This philosophy, as we know, used the word “ether” to designate the particular kind of matter that filled the universe. This term was used throughout the history of philosophy and science, and it was also current at the beginning of this century. A resumption of its use at the dawn of this new century is now a fact. Since, according to General Theory of Relativity and other modern branches of physics, the space and time of the universe do not constitute a vacuum, but a structured material plenum characterized by different physical quantities, the historical and

Max Born put forward the hypothesis that it was a probability, and for that reason should be normalized, which is equivalent to assigning to it an arbitrary amplitude selected by the theorist. Thus, starting from a synthetic idea of the coexistence in physical space of waves and particles, a theory in which there was no longer any wave or particle was arrived at!...But as soon as Schrödinger’s works were published I was struck by the paradox involved, as indeed I had already emphasized in an article which appeared in 1928 [*Selected Papers on Wave Mechanics*, London: Blackie, p. 130]. For since Schrödinger gave up the idea that particles existed in physical space, they no longer have well defined coordinates and it is difficult to imagine how the configuration space can be constructed with nonexistent coordinates...It may assist in clarifying this point to recall that in classical mechanics particles are treated as a first approximation as material points which have well defined coordinates in physical space at every moment...But this representation, clear and logical though it is, loses all its meaning in a theory in which particles have no spatial position as in current quantum mechanics” (ibid).

⁴⁶⁰ Albert Einstein, “Grundgedanken und Methoden der Relativitätstheorie in ihrer Entwicklung dargestellt,” *Morgan Manuscript*, EA 2070, as cited in Ludwik Kostro, *Einstein and the Ether*, Aperion, 2000, p. 2.

traditional word “ether” is the most appropriate to express these features of the universe.⁴⁶¹

Astrophysicist Toivo Jaakkola puts things in perspective:

A few words about the gravitational ether, and the ether concept in general may be in place here. The ether hypothesis was thought to be buried by the Michelson-Morley experiment, but today it is more alive than ever, in the form of the CBR [Cosmic Background Radiation]: experiments capable of finding the ether were not possible in the 1880s, but were possible in the 1960s. In a sense, the electromagnetic ether has always been observed – as the heat of the Sun (since as pointed out, CBR is reprocessed photons)... All the main cosmological, astrophysical and physical facts: the gravity and Olbers paradoxes, redshift effects and CBR, gravitation and radiation, and the existence of particles can be conceived in the framework of this ether concept.⁴⁶²

Lastly, the authors of the book, *The Philosophy of Vacuum*, state:

Today the vacuum is recognized as a rich physical medium....A general theory of the vacuum is thus a theory of everything, a universal theory. It would be appropriate to call the vacuum “ether” once again.⁴⁶³

Later in our treatise we will find that the very ether Louis de Broglie desired offers a solution to the wave/particle conundrum that has hampered modern science since de Broglie first discovered that electrons produce waves. Any particle that moves through a medium will, indeed, create waves. In fact, a return to ether will help solve one of the most mysterious and perplexing problems in Quantum Mechanics today, the phenomenon of “entanglement” – the spooky connection between pairs of photons, electrons or atoms even though they are separated by great distances. Perhaps this was why [John Stewart Bell](#), the inventor of Bell’s Theorem to answer the phenomenon of entanglement, stated in a BBC radio interview: “Yes, the idea that there is an ether...that is a perfectly coherent point of view.”⁴⁶⁴

⁴⁶¹ Ludwik Kostro, *Einstein and the Ether*, Montreal, Apeiron, 2000, pp. 186-187.

⁴⁶² “Action-at-a-Distance and Local Action in Gravitation,” in *Pushing Gravity*, ed., Matthew Edwards, pp. 157-159.

⁴⁶³ S. Saunders and H. R. Brown, editors, *The Philosophy of Vacuum*, Oxford, Clarendon Press, 1991, p. 251.

⁴⁶⁴ Ludwik Kostro, *Einstein and the Ether*, p. 154, citing M. Jammer’s, “John Stewart Bell and the Debate on Significance of his Contributions to the Foundations of

Quantum Mechanics,” in *Bell’s Theorem and the Foundations of Modern Physics*, eds. A. Van der Merwe, F. Felleri, G. Tarozzi, Singapore, New Jersey, World Scientific, 1992, p. 5; also cited in P. C. W. Davies and J. R. Brown, eds., *The Ghost in the Atom*, Cambridge University Press, 1986, pp. 49-50.

“Isn’t the Bible Merely Using Figurative Language?”

Another common objection levied against geocentrism from both scientists and modern biblical exegetes is that when Scripture employs language such as “the sun rises” or “the sun sets,” it is merely attempting to express the motions of the heavenly bodies in figurative or phenomenal language, since a “rising” or “setting” of the sun is the view that a person standing on Earth would observe, but it is not the true reality. The astronomer will argue that even though he sees the sun rise over the horizon, he, being a knowledgeable scientist, knows that in reality it is the Earth rotating on its axis against the sun that only makes it appear as if the sun is rising. Likewise, the biblical exegete will often point to figurative language employed hundreds of times in Scripture (e.g., Psalm 98:8: “Let the floods clap their hands: let the hills be joyful together”) and insist that the sun’s “rising” is of the same linguistic genre and thus need not be interpreted literally. The Catholic may even refer to the words of [Pope Leo XIII](#) in his teaching about the interpretation of Scripture:

The unshrinking defense of the Holy Scripture, however, does not require that we should equally uphold all the opinions which each of the Fathers or the more recent interpreters have put forth in explaining it; for it may be that, in commenting on passages where physical matters occur, they have sometimes expressed the ideas of their own times, and thus made statements which in these days have been abandoned as incorrect.⁴⁶⁵

⁴⁶⁵ The 1893 encyclical: *Providentissimus Deus: On the Study of Holy Scripture*, “Natural Sciences,” Boston, Pauline Books and Media, p. 24. All in all, Leo XIII reinforced the traditional “literal” approach to Scripture interpretation, as noted in the following statement of the same encyclical: “For Sacred Scripture is not like other books. Dictated by the Holy Spirit, it contains things of the deepest importance, which, in many instances, are most difficult and obscure” (p. 8); “Now we have to meet the Rationalists...who...set down the Scripture narratives as stupid fables and lying stories” (p. 12); “The Church...renewing the decree of Trent declares...the true sense of Holy Scripture...whose place it is to judge of the true sense and interpretation of the Scriptures; and, therefore, that it is permitted to no one to interpret Holy Scripture against such sense or also against the unanimous agreement of the Fathers” (pp. 16-17); “But he must not on that account consider it is forbidden, when just cause exists, to push inquiry and exposition beyond what the Fathers have done; provided he carefully observes the rule so wisely laid down by St. Augustine – not to depart from the literal and obvious sense, except only where reason makes it untenable or necessity requires; a rule to which it is the more necessary to adhere strictly in these times, when the thirst for novelty and unrestrained freedom of thought make the danger of error most real and proximate.” (pp. 18-19); “But it is absolutely wrong and forbidden to narrow inspiration to certain parts only of Holy Scripture or to admit that the sacred writer has erred...because (as they wrongly think) in a question of the truth or falsehood of a passage we should consider not so much what God has said as the reason and purpose which He had in mind in saying it – this system cannot be tolerated” (pp. 25-26); “Let them loyally hold that God, the Creator and Ruler of all things, is also the Author of the

The skeptic may also quote [Pope Pius XII](#) for the same purpose:

For of the modes of expression which, among ancient peoples, and especially those of the East, human language used to express its thought, none is excluded from the Sacred Books [The Bible], provided the way of speaking adopted in no wise contradicts the holiness and truth of God, as, with his customary wisdom, the Angelic Doctor already observed in these words: “In Scripture divine things are presented to us in the manner which is in common use amongst men.” For as the substantial Word of God became like to men in all things, “except sin,” so the words of God, expressed in human language, are made like to human speech in every respect, except error.⁴⁶⁶

Invariably, Catholic biblical exegetes who choose not to entertain the idea that the universe is geocentric frequently appeal to the above papal statements for support of their position. They will conclude that both Leo XIII and Pius XII could not have been teaching us anything else but that we are to interpret Scripture’s references to the movement between the Earth and sun in light of the discovery of heliocentrism by Copernicus and Galileo. As far as these exegetes are concerned, the case is closed, since the popes did not require us to interpret descriptive phrases such as “the sun rises” in a literal fashion, but wanted us to see them as either ancient expressions of uneducated peoples or phenomenal language from the point of view of an observer on the surface of the Earth. In either case, it is assumed that the popes were accepting heliocentrism and demoting geocentrism.

Upon closer examination, however, this conclusion is more a ‘reading into’ what the popes actually said than a fair and accurate understanding of their words. First, in each of the above papal citations, neither pontiff makes a specific reference to Scripture’s cosmological

Scriptures – and that, therefore, nothing can be proved either by physical science or archaeology which can really contradict the Scriptures” (pp. 28-29).

⁴⁶⁶ The 1943 encyclical: *Divino Afflante Spiritu: The Promotion of Biblical Studies*, “The Importance of mode of writing,” Boston, Pauline Books and Media, p. 21. Pope Pius XII also added this important warning: “Hence the Catholic commentator, in order to comply with the present needs of biblical studies, in explaining the Sacred Scripture and in demonstrating and proving its immunity from all error, should...determine...to what extent the manner of expression or the literary mode adopted by the sacred writer may lead to a correct and genuine interpretation; and let him be convinced that this part of his office cannot be neglected without serious detriment to Catholic exegesis. Not infrequently – to mention only one instance – when some persons reproachfully charge the Sacred Writers with some historical error or inaccuracy in the recording of facts, on closer examination it turns out to be nothing else than those customary modes of expression and narration peculiar to the ancients...” (pp. 21-21).

passages, thus no one can claim that the popes were referring to the movements of either the sun or the Earth. The popes could have been referring to any number of instances in which Scripture speaks in phenomenal language. Second, the most important fact that is invariably missed by modern biblical exegetes who advocate heliocentrism is that Scripture's phenomenal language (e.g., the "sun rises" or the "sun sets") also applies to the geocentric system. In the geocentric system the sun does not "rise" or "set"; rather, it revolves around the Earth. When the geocentrist sees a beautiful sunset he does not remark: "Oh, what a beautiful revolution of the sun," just as a heliocentrist does not say: "Oh, what a beautiful rotation of the Earth." The geocentrist knows that the sun "rises" or "sets" only with respect to the Earth's horizon, and therefore, reference to a "rising sun" in Scripture is just as phenomenal in the geocentric system as it is in the heliocentric. On that basis alone neither Leo XIII's nor Pius XII's above directives can be understood as advocating heliocentrism or denying geocentrism, especially in light of the fact that three pontiffs prior to them had, based on other criteria, denied heliocentrism and advocated geocentrism, as the historical records show quite clearly (and which we will examine in more detail later in this volume and comprehensively in Volume II).⁴⁶⁷

Moreover, Pius XII's above quotation from the words of the "Angelic Doctor" [Thomas Aquinas](#) ("In Scripture divine things are presented to us in the manner which is in common use amongst men") cannot be interpreted as Pius' attempt to promote heliocentrism, since it is a fact of history that St. Thomas Aquinas was an avowed geocentrist who never entertained the possibility of heliocentrism.⁴⁶⁸ Obviously, then, Thomas could not have intended his insights on biblical interpretation to be used either to deny geocentrism or promote heliocentrism. These insights were merely his general teaching on the various modes of speech employed by the authors of Scripture, which can be applied to many and varied phenomena in nature.

Lastly, although it is safe to say that phrases such as "the sun rises" or "the sun sets" are to be considered phenomenal from both the heliocentric and geocentric perspectives, this does not mean that Scripture *always* limits itself to phenomenal language when it addresses the movement of the heavenly bodies. The language of appearance only applies to expressions *when appearance is the intended feature*. One can

⁴⁶⁷ Pope Paul V in 1616; Pope Urban VIII in 1633; and Pope Alexander VII in 1664.

⁴⁶⁸ Thomas Aquinas wrote: "The Earth stands in relation to the heaven as the center of a circle to its circumference. But as one center may have many circumferences, so, though there is but one Earth, there may be many heavens" (*Summa Theologica*, "Treatise on the Work of the Six Days," Question 68, Article 4). By "many heavens" Thomas is referring to the three ways in which Scripture uses the word "heaven," e.g., the Earth's atmosphere; the starry cosmos; and the third heaven as God's domain above the firmament.

easily surmise from such passages (e.g., “the sun rises” or “the sun sets”) that although Scripture may express the appearance of the movement from the perspective of the observer on Earth, nevertheless, Scripture affirms that, of the two bodies, one of them moves and the other does not. In that particular category, Scripture is adamant that it is the sun that moves, not the Earth; and thus it is the sun that is the circling body that causes the *appearance* of the sun rising or setting over the horizon, as well as the [four seasons](#). Similarly, there are many other passages of Scripture that are much more specific concerning the movement of the sun and the immobility of the Earth. Those particular passages will be addressed in Volume II of this series.⁴⁶⁹

⁴⁶⁹ Joshua 10:10-14; Judges 5:31; 2Kings 20:9-11; 1Chronicles 16:30; 2Chronicles 32:24; Isaiah 13:10; 38:7-8; 66:1; Acts 7:49; Job 9:7; 26:7; Psalm 19:1-6; 93:1; 96:9-10; 104:5, 19; 119:90; Ecclesiastes 1:4; Habakkuk 3:11; Ecclesiasticus (Sirach) 43:1-10; 46:4-5; James 1:17; 1Esdras 4:34 (apocryphal). We will also address the various passages that have been purported to support heliocentrism (e.g., Job 9:6; 26:7; 38:14, 31-33; Psalm 82:5; 99:1; Isaiah 13:13; 24:19-20).

Then spoke Joshua to the LORD in the day when the LORD gave the Amorites over to the men of Israel; and he said in the sight of Israel, "Sun, stand thou still at Gibeon, and thou Moon in the valley of Aijalon."

And the sun stood still, and the moon stayed, until the nation took vengeance on their enemies. Is this not written in the Book of Jashar? The sun stayed in the midst of heaven, and did not hasten to go down for about a whole day.

There has been no day like it before or since, when the LORD hearkened to the voice of a man..."

Joshua 10:12-14

"We, however, who extend the accuracy of the Spirit to the merest jot and tittle, will never admit the impious assertion that even the smallest matters were dealt with haphazard by those who have recorded them"

St. Gregory of Nanzianzus,
Oration II, n. 104

...the famous experiment of Michelson and Morley undertaken to measure the so-called absolute velocity of the Earth..."

Max Planck⁴⁷⁰

"This conclusion directly contradicts the explanation... which presupposes that the Earth moves..."

Albert Michelson⁴⁷¹

"...Albert Michelson from Chicago whose celebrated experiments are the main foundation of relativity."

Max Born⁴⁷²

"There was just one alternative; the earth's true velocity through space might happen to have been nil..."

Arthur Eddington⁴⁷³

⁴⁷⁰ Max Planck, *Scientific Autobiography and Other Papers*, New York: Philosophical Library, 1949, p. 139.

⁴⁷¹ Albert A. Michelson, "The Relative Motion of the Earth and the Luminiferous Ether," *American Journal of Science*, Vol. 22, August 1881, p. 125, said after his first interferometer experiment could not detect the movement of ether against the Earth.

⁴⁷² Letter dated March 28, 1961 from Max Born to Michelson's daughter, Dorothy Michelson Livingston, as cited in her work: *The Master of Light: A Biography of Albert A. Michelson*, p. 256.

⁴⁷³ Arthur Eddington, *The Nature of the Physical World*, New York, Macmillian Company and Cambridge University Press, 1929, pp. 11, 8, in sequence.

Chapter 5

Albert Einstein and the Interferometers: The Frightening Possibility of a Motionless Earth

The “Unthinkable” Proposition

It is one thing to deal with scientific evidence that indicates Earth is at or near the center of the universe, but what does one do with evidence that narrows down the field a bit more than expected? What if the evidence shows that Earth is not only the center of the universe but that it doesn't move at all? This brings us to a few decades before gamma-rays, quasars and most galaxies were discovered, to a time when science was at a major crossroads, and whose outcome would determine the course of history for centuries to come.

Without question, no one has influenced physics and cosmology more than [Albert Einstein](#) (1879-1955). His name has become a household word, one associated with superior intelligence and foresight. His work has inspired many a young man to take up the mantle and advance the cause of science, and even philosophy and politics. But as with many popular figures, they are often bigger than life, and soon the myths surrounding the person become more popular and accepted than the actual person himself. This is especially true with Einstein. Most people know very little behind the image of the wire-haired, absent-minded professor or the floating formula $E=mc^2$ they see in scenic backgrounds of movies and television. They know very little concerning how Einstein's famous theory of Relativity was born or what it means. Often the extent of their knowledge is the oft used cliché “everything's relative.”

In reality, Einstein was the forerunner to Hubble, Hawking, Sagan and the rest of modern science's icons who have done their best to preserve Copernican cosmology in the face of evidence that strongly indicated it was seriously flawed. Similar to Edwin Hubble who stated that an Earth-centered cosmos would be “intolerable” and “must be avoided at all costs,” so Einstein gave birth to Relativity for precisely the same reason, only his biographer chose the word “unthinkable.” After the famous Michelson-Morley experiment of 1887, Ronald W. Clark describes what came next:

The problem which now faced science was considerable. For there seemed to be only three alternatives. The first was that the Earth was standing still, which meant scuttling the whole Copernican theory and was *unthinkable*.⁴⁷⁴

⁴⁷⁴ *Einstein: The Life and Times*, Avon Book, New York, NY, 1984, p. 109-110. Emphasis added. In the opposite vein, senator James W. Fulbright once remarked: “We

We have to give credit to Clark for even mentioning a motionless Earth as a possible explanation to this famous experiment, for many other biographers and historians do not even allow their readers the privilege of knowing that such an option exists. Some allude to the possibility, but even then it is treated anachronistically, as in G. J. Whitrow's comment that a very simple explanation to the Michelson-Morley experiment is that the Earth doesn't move, but only...

if such an experiment could have been performed in the sixteenth or seventeenth [centuries] when men were debating the rival merits of the Copernican and Ptolemaic systems. The result would surely have been interpreted as conclusive evidence for the immobility of the Earth, and therefore as a triumphant vindication of the Ptolemaic system and irrefutable falsification of the Copernican hypothesis.⁴⁷⁵

The scientific community would much rather the public not entertain such ideas, let alone seriously study them. Nevertheless, as Clark forthrightly reveals, a motionless Earth was one of the scientific alternatives to explain one of the most important and puzzling experiments of human history. Sadly, he also shows that scientists were so ingrained in Copernican thinking that no one would even dare question whether heliocentrism was really true, even when evidence against it was staring them in the face. It was as preposterous as saying that the sky is green or that grass is pink. As the historical record will show, so "unthinkable" was this alternative that scientists were in a virtual frenzy to find some way to dispel it, to relieve themselves of having to dethrone their heroes: Copernicus, Galileo, Kepler and Newton, or be required to give a posthumous apology to St. Robert Bellarmine and Popes Pius V, Urban VIII and Alexander VII.⁴⁷⁶

Later, when Einstein was inventing his second leg of the theory, General Relativity, the decision had already been made. Clark writes:

As Einstein wrestled with the cosmological implications of the General Theory, the first of these alternatives, the Earth-

must care to think about the unthinkable things, because when things become unthinkable, thinking stops and action becomes mindless."

⁴⁷⁵ G. J. Whitrow, *The Structure and Evolution of the Universe*, New York, Harper and Brothers Publishers, 1959, p. 79.

⁴⁷⁶ St. Robert Bellarmine was head of the Sacred Congregation for the Faith in the trial of Galileo in 1616 under Pius V; in 1633 Urban VIII upheld the decision of Pius V and put Galileo under house arrest for continuing to teach the Copernican theory, while in 1664 Alexander VII issued a papal bull containing condemnations of Copernicus, Galileo and Kepler.

centered universe of the Middle Ages, was effectively ruled out...⁴⁷⁷

Interestingly enough, in Clark's entire autobiography of Einstein, which amounts to 878 pages, not one reason, or even a suggestion of a reason, is ever cited as to why, scientifically speaking, the Earth-centered universe was "ruled out." In fact, no other biography, or even autobiography, of Einstein gives a reason to the "ruling out" of geocentrism. Heliocentrism is just assumed as fact, and a fact upon which every other decision in physics would be made for the next one hundred years. As Einstein himself said about heliocentrism: "Even this simple idea, so clear to everyone, was not left untouched by the advance of science. But let us leave this question for the time being and accept Copernicus' point of view."⁴⁷⁸

We can, however, sympathize with their plight. One can imagine the sheer embarrassment science would face if it had to apologize for 500 years of propagating one of the biggest blunders since the dawn of time. This was not the medieval period, a time in which mistakes could be excused because of primitive scientific tools and superstitious notions. This was the era of Newton, Lavoisier, Maxwell, Faraday, Pasteur, Dalton, Darwin, Lyell and scores of other heroes of science. If heliocentrism was wrong, how could modern science ever face the world again? How could it ever hold to the legacy left by these giants if it had to admit that it was wrong about one of its most sacrosanct and fundamental beliefs? Admitting such a possibility would put question marks around every discovery, every theory, every scientific career, every university curriculum, especially the theory of evolution, which was just coming into its own in the late 1800s and early 1900s. The very foundations of modern life would crumble before their eyes. Not only would Earth, literally, become immobile, but it would figuratively come to a halt as well, for men would be required to revamp their whole view of the universe, and consider the most frightening reality of all – that a supreme Creator actually *did* put our tiny globe in the most prestigious place in the universe. Only fools would conclude that Earth could occupy the center of the universe by chance. Compared to the rediscovery of an immobile Earth the Renaissance and the Enlightenment would be mere flights of fancy built on pretentious energy. Most of all, science would have to hand the reins of power and influence back to the Church and to Scripture, since it is from those sources alone that the teaching of a motionless Earth never wavered. In short, the entire future of mankind's existence hung in the balance after the Michelson-Morley experiment.

⁴⁷⁷ *Einstein: The Life and Times*, p. 267.

⁴⁷⁸ Albert Einstein and Leopold Infeld, *The Evolution of Physics*, New York, Simon and Shuster, 1938, 1966, pp. 154-155.

Could science produce a savior to lead the world away from the clutches of this spoiler?

Enter [Albert Einstein](#). To save the world from having to reconnect itself with the Middle Ages, Einstein set his mind to finding an explanation to the [Michelson-Morley experiment](#). Most people don't realize, and even less would admit it, but Relativity was created for one main reason: so that mankind would not be forced to admit that Earth was standing still in space. As his contemporary, Max von Laue stated:

Thus, a new epoch in physics created a new mechanics...it began, we might say, with the question as to what effect the motion of the Earth has on physical processes which take place on the Earth...we can assign to the dividing line between epochs a precise date: It was on September 26, 1905, that Albert Einstein's investigation entitled "On the Electrodynamics of Bodies in Motion" appeared in the *Annalen der Physik*.⁴⁷⁹

In fact, Einstein would be called "a new Copernicus."⁴⁸⁰ Unbeknownst to the world, however, Einstein's explanation would not only require a total revamping of science, it would necessitate the acceptance of what *The Times* of London called "an affront to common sense,"⁴⁸¹ forcing his fellow man to accept principles and postulates that heretofore would have been considered completely absurd. Einstein would require men to believe that matter shrunk in length and increased in mass when it moved, that clocks slowed down, that two people could age at different rates, that space was curved, that time and space would meld into one, and many other strange concepts. But in the end, as we will see unfold before us in a most ironic drama, what Einstein's Special Relativity took away with the left hand, his General Relativity restored ten years later with the right hand. As van der Kamp puts it:

No question about it: if STR [Special Theory of Relativity] is true then the logically understandable hierarchical and Earth-centered universe of antiquity and the Middle Ages was a pipe dream. The problem remains the "if" in the last sentence....In the present context I am satisfied with the undeniable actuality that though STR presumably allowed the astronomers to escape from a geocentric bugbear – and a daunting argument from

⁴⁷⁹ *Albert Einstein: Philosopher-Scientist*, p. 523. Einstein does not specifically mention either Michelson-Morley's experiment or any other preceding experiment in "On the Electrodynamics of Moving Bodies," rather, he makes allusion to all of the preceding experiments with light in the statement: "...the unsuccessful attempts to discover any motion of the Earth relatively to the 'light medium.'"

⁴⁸⁰ *Einstein: The Life and Times*, p. 192.

⁴⁸¹ *Einstein: The Life and Times*, p. 101.

design behind it – the GTR [General Theory of Relativity] has been compelled to declare the Earth-centered model “as good as anybody else’s, but no better”... after Einstein...burst for the second time upon the scene the tables were turned...the geocentric model of the universe, be it absolutely unacceptable, science cannot show it to be wrong...the theoretical status of the Earth-centered concept is today under Einstein’s regimen higher than it has ever been since the 1687 publication of Newton’s *Principia*, the ruling model now “giving increased respectability to the geocentric picture.”⁴⁸²

Nevertheless, Einstein’s relativistic contortions were a small price to pay to save the world from the embarrassment of having to admit that it had been wrong for six centuries about one of the most fundamental issues of life. Accordingly, Van der Kamp remarks on the pressure to which students are forced to accept Relativity theory:

As science teachers know: when students for the first time are introduced to the special theory of relativity it is not the dullards in the class who initially are often unwilling to reconcile themselves to it. Until, of course, they begin to realize that a refusal logically constrains them to part with Copernicus’ system. Which system, thanks to Galileo and his apostles, they have been brainwashed to deem ‘obvious.’ And therefore seeing no other way out of the dilemma, no other acceptable possibility in sight, they close their eyes and swallow what in their hearts they know to be impossible [STR] but gradually and under persistent peer pressure are converted into believing as scientific and self-evidently true truth....If we accept Copernicus there is no way around it. The wearying trouble is that “if.”⁴⁸³

Dean Turner provides the same insight:

Many writers pretend to understand [relativity], but simply do not. Many otherwise alert students studying relativity become

⁴⁸² Walter van der Kamp, *De Labore Solis*, pp. 46-48, 55, 61, the first quote from the popular astronomer Fred Hoyle in *Frontiers of Astronomy*, New York: Harper and Row, 1963, p. 304; the second also from Hoyle in *Nicolaus Copernicus: An Essay on His Life and Work* (New York: Harper and Row, 1973, p. 87. Others are convinced that Relativity is just a simple modification of nature. Stephen Hawking writes: “The theory of relativity does, however, force us to change fundamentally our ideas of space and time. We must accept that time is not completely separate from and independent of space, but is combined with it to form an object called space-time” (*A Brief History of Time*, p. 23). Gerald Holton, who is otherwise reliable, softens quite noticeably in the aura of Einstein, even suggesting that Relativity theory is “an effort to return to classical purity” (*Thematic Origins*, p. 195).

⁴⁸³ *De Labore Solis*, pp. 50-51.

logically bewildered and lose confidence in their own ability to think clearly as they slip into mysticism and become the next generation of scientific priests...The public has trusted the physicists, trusted them perhaps more, in this generation, than any other group. But in time, people will learn that physicists are no more immune to the perverse motivational currents of the times than any other professional people. Scientists have enormous vested interests in protecting their theories – vested energy, time, money and indeed reputation. Like most other human beings, many are less than saintly in possessing the attributes of honesty, unselfishness and respect for truth...For seventy-two years [1905-1977] humanity has been browbeaten by an incomparably brazen bit of pseudo-science because its perpetrators have defended it by using mathematics which, though valid in itself, is not applied in relation to objective facts that are analyzed logically in the real world. Recondite kinds of higher mathematics have been falsely used to create an awesome, esoteric language whereby the initiated elite have set themselves apart from the world and have labeled all dissenters as quacks.⁴⁸⁴

⁴⁸⁴ Richard Hazelett and Dean Turner, *The Einstein Myth and the Ives Papers: A Counter-Revolution in Physics*, Greenwich, CT, Devin-Adair Co. publishers, 1979, pp. 88-91.

The Significance of the Michelson-Morley Experiment

The Michelson-Morley interferometer experiment was a simple one. The hypothesis was this: if the Earth is presently moving through space at a clip of 66,000 mph around the sun, and this movement is through a medium that fills all of space (at that time it was called “ether,” a view opposed to Relativity’s belief that space is a vacuum), then a light beam discharged from Earth in the direction of the Earth’s supposed motion should logically find its speed impeded to a degree proportional to the speed of the Earth. Light, even though it seems to be without substance, can be impeded by the medium through which it travels. We see these effects quite readily when, for example, we put a pencil in a glass of water and observe how the light rays are bent, or slowed down, by the water, and thus make the pencil appear broken. The decrease in light’s speed can be measured quite accurately. By the same token, the Michelson-Morley experiment would show that a light beam discharged from the north pole to the south pole, or vice versa, would experience no change in speed, since it would not be moving in the direction of Earth’s path around the sun and thus not against the ether.

[Albert Michelson](#) and [Edward Morley](#) were anticipating being able to measure the difference in speed because of their previous success in repeating [Armand Fizeau’s experiment](#) with light in moving water. With their new *interferential refractometer*, as it was originally called, they would be able to determine effects of the second order with an accuracy that was previously unobtainable. Thus Morley wrote to his father that the purpose of the experiment was “to see if light travels with the same velocity in all directions.”⁴⁸⁵ To everyone’s utter surprise, Michelson and Morley found that a light beam discharged in the direction of the Earth’s assumed motion showed virtually no difference in speed from a light beam discharged north to south or south to north. In other words, the experiment failed to detect the Earth moving in or against space, of whatever space was understood to consist. As one can imagine, this result was of great concern to Einstein.

⁴⁸⁵ Letter dated April 17, 1887, in the Edward W. Morley Papers, Library of Congress, as cited in Dorothy Michelson Livingston’s *Master of Light: A Biography of Albert Michelson*, New York, Charles Scribner, 1973, p. 126.

Einstein's Concern for the Fizeau and Airy Experiments

The Michelson-Morley experiment was not the only one that was of concern to Einstein, however. In fact, since Einstein was well aware of previous experiments with the same results, he probably would have expected a negative result from Michelson-Morley. We suspect this to be the case since interviews with Einstein show that he was more concerned with the results of experiments performed about 10-50 years earlier. Robert Shankland's interview with Einstein reveals the details:

Prof. Einstein volunteered a rather strong statement that he had been more influenced by the Fizeau experiment on the effect of moving water on the speed of light, and by astronomical aberration, especially Airy's observations with a water-filled telescope, than by the Michelson-Morley experiment.⁴⁸⁶

Why would the "Fizeau experiment" and "especially Airy's observations with a water-filled telescope," cause such consternation in the mind of Einstein? Very simply, Armand Fizeau and [George Biddell Airy's](#) experiments are two of the foremost evidences of a motionless Earth ever produced by man. Einstein's contemporary, [Hendrik Lorentz](#), stated quite succinctly that these experiments put unbridled fear into the science establishment. In remarking on those same experiments Lorentz wrote this astounding admission: "Briefly, everything occurs as if the Earth were at rest..."⁴⁸⁷ Eventually, it would take the full force of

⁴⁸⁶ Robert S. Shankland, "Conversations with Albert Einstein," *American Journal of Physics*, 31:47-57, 1963, and specifically the follow up report in 41:895-901, 1973, p. 896. Einstein repeated this same concern on a number of occasions, each time minimizing the impact of Michelson-Morley against Airy and the stellar aberration experiments. For a running commentary on these occasions, see Gerald Holton's *Thematic Origins of Scientific Thought*, pp. 191-370.

⁴⁸⁷ From Lorentz's 1886 paper, "On the Influence of the Earth's Motion of Luminiferous Phenomena," as quoted in Arthur Miller's *Albert Einstein's Special Theory of Relativity*, p. 20. Although Miller, an avowed heliocentrist, does not admit to a concern that the Copernican system might be overturned by the Fizeau/Airy evidence, his consistent references to being required to view things from the "geocentric system" shows that he is at least aware of the differences (e.g., "The stellar aberration of light from a fixed star is observed in the *geocentric system*....If, in the *geocentric system*, c was the light velocity from a star – v was the star's velocity relative to the Earth (i.e., $v = 30\text{km/sec}$ which is the Earth's velocity relative to the sun)...At the time t in the *geocentric system* there is a point P on a spherical wave front, and the wave is traversing a medium of refracted index N that is at rest on the Earth...Consider, in the *geocentric system*, a water-filled telescope...Lorentz continued (1886), by noting that from the viewpoint of the *geocentric system*...(pp. 15, 19, emphases added). Also revealing are the times Arthur Miller makes such statements as: "optical phenomena were unaffected by the Earth's motion" or "interferometer experiments could not detect the Earth's motion..." (p. 20) yet, because he has accepted heliocentrism as an absolute, he cannot find it within himself to entertain the possibility that the Earth is actually not in motion.

Relativity theory and its attendant Lorentzian-derived “transformation equations” to make even an attempt at explaining the amazing results of Fizeau, Airy and various stellar aberration experiments.⁴⁸⁸ The Michelson-Morley experiment was merely a desperate effort, using more sophisticated equipment, to overturn Fizeau and Airy’s findings, but as noted above, it failed to do so.⁴⁸⁹

Einstein’s biographer probably didn’t even know this history when he wrote that, after the Michelson-Morley experiment, men were faced with the possibility of “scuttling the whole Copernican theory.” Unlike Einstein, most such biographers have fixated on the cart but were rather oblivious to the horse. All in all, we can say this much for Einstein: although his theories were certainly fantastic to the point of absurdity, at least he was smart enough to know from whence his opposition came. In the battle for the cosmos, the unexpected results of the Fizeau and Airy experiments had already put modern science on trial, but since they both produced anti-Copernican results, the clarion call to the courtroom was not being trumpeted to the rest of the world. For the rest of his career Einstein would do everything in his power to stop it from sounding. As van der Kamp has stated: “Yes, I think I understand the sentiment motivating him. If we cannot prove what we *a priori* ‘know’ to be true [a moving Earth], then we have to find a reason why such a proof eludes us.”⁴⁹⁰ And thus was born the theory of Relativity.

⁴⁸⁸ Arthur Miller claims “Einstein did not have to discuss the experiments of Airy and Arago because special relativity theory reduced their observations to a foregone conclusion.” As we can see from Shankland’s interview (above), Miller is quite wrong about Einstein’s motivations. Not only did Einstein “discuss...Airy,” but he considered it a formidable puzzle that had to be answered.

⁴⁸⁹ As physicist Herbert Ives reminds us: “It must not be forgotten in the discussion of this subject that the Michelson-Morley experiment...only demands invariance of light signals with the velocity of the moving platform of measurement *on the premise that the Earth is moving* – there is no other motion involved in the experiment. If this is not agreed to then the null result proves nothing with regard to invariance, and the whole discussion is futile” (“Light Signals on Moving Bodies,” *Journal of the Optical Society of America*, July 1937, Vol. 27, p. 271, emphasis added). The corollary, of course, is that the Earth may not be moving.

⁴⁹⁰ *De Labore Solis*, p. 43. As we will see shortly, all claims that the Earth is moving based on stellar aberration are presumptuous, since from Airy’s experiment it has been proven that the necessity of tilting a telescope to catch all of a star’s light is due to a fixed Earth in a moving star system, not a moving Earth in a fixed star system. Interestingly enough, the type of experiment Airy performed was suggested more than a century earlier in 1766 by Ruggiero Guiseppe Boscovich (1711-1787), a Jesuit astronomer, and again by Fresnel in 1818, which may have been the source of Airy’s idea. In 1746 Boscovich published a study on the elliptical orbits of the planets based on the Copernican system (*De Determinanda Orbita Planeta ope catoptrica*, Rome 1749). He published a second edition in 1785 (*Opera Pertinentia ad Opticam et Astronomiam*, Bassan, 1785). Perhaps if Boscovich had had the good fortune to

When one reads Einstein's works there appears to be no ostensible concern that these experiments could "scuttle the whole Copernican theory," nevertheless, there is an undercurrent in his writings that he is indeed cognizant of such implications yet does his best not to alarm the world. Even in private his concerns are subtle. In an exchange with [Willem de Sitter](#) in 1917 over whether the universe was a "3-dimensional hypersphere embedded in a 4-dimensional Euclidean space" or a "4-dimensional hypersphere embedded in a 5-dimensional Euclidean space," Einstein objected to de Sitter's 4-5 model based mainly on the fact that it had "*a preferred center*."⁴⁹¹

Relativity theory, by its very nature, is especially susceptible to anti-Copernican interpretations, since for everything that Relativity claims for itself in the way of a moving Earth in a fixed universe can easily be "relativized" for a fixed Earth in a rotating universe. In fact, stellar aberration was indeed a major concern of Einstein's for that very reason, since Relativity theory, in principle, demands equal viability for both of the aforementioned perspectives.⁴⁹² Einstein's concern was justified. As we will see, Airy's experiment threw a wrench into the reciprocity of Relativity, for it demonstrated that it really does make a difference whether the Earth is moving or at rest in regards to how light from a star travels through a telescope mounted on the Earth. Consequently, Einstein could not "relativize" the results of Airy's experiment, since stellar aberration provided a distinction he could not readily overcome. Consequently, Einstein would be forced to resort to the *ad hoc* "field transformation" equations of Hendrik Lorentz to answer Airy's results; and although others didn't voice their opinions too loudly for fear of being ostracized, everyone knew that Einstein's efforts were just mathematical fudge factors. There was one inescapable fact that Airy's telescope was revealing: barring any mathematical fudging, Earth was standing still and the stars were revolving around it, not vice-versa.

perform an Airy-type experiment, he might have thought twice about adopting the Copernican system.

⁴⁹¹ "The Einstein-De Sitter Debate and Its Aftermath," Michael Janssen, University of Minnesota, class handout, p. 3.

⁴⁹² Einstein demonstrated this in his 1911 paper "Über den Einfluß der Schwerkraft auf die Ausbreitung des Lichtes," *Annalen der Physik*, 35, 903f. According to Einstein, the argument of whether the Earth rotates or the heavens revolve around Earth is understood as nothing more than a choice between reference frames. The Earth's poles would flatten from either reference frame, says Einstein. In the frame of a rotating Earth in a fixed star system, the centrifugal force is a consequence of the Earth's uniform acceleration relative to the fixed stars. In a fixed Earth frame, Einstein says the centrifugal force is attributed to the effect of "the rotating masses" [stars] that are generating a gravitational field that causes the Earth's poles to flatten. The two frames are said to be equivalent, since there is equivalence between inertial mass and gravitational mass. As we will see later, the flattening of the Earth's poles occurs, according to Einstein, because the gravity of the stars creates a curvature of the space-time fabric surrounding the Earth.

Hence, the importance of the Michelson-Morley experiment was that it confirmed, by a significantly different kind of experiment, the same results that Airy found in his water-filled telescope sixteen years earlier. But before we get to Airy's actual experiment we need to cover the history that led up to it.

The Experiments of Dominique Arago

The “Fizeau experiment” and “Airy’s observations” that Einstein mentions in the above interview have their impetus for concern a few years prior in the work of [Dominique François Arago](#) (1786-1853). Arago is one of France’s most celebrated scientists. He had his hands in many fields of interest, but his unique work with light set the pace for many years to come. For our purposes, there are two things of note in his discoveries between the years 1810 to 1818. First, Arago observed one star through a telescope for the whole course of a year. In that year, the star would move toward the Earth and then move away (which is true in either the heliocentric or geocentric frames). Arago reasoned that the focal length of his telescope would have to change in viewing the star, since the speed of light coming from a receding star would be different from that of an approaching star (in the heliocentric system it would be the Earth moving toward or away from the star). To his astonishment, he observed no difference and thus he was not required to change the focal length. This was the first indication that the stars were far enough away that, regardless of whether the Earth was moving, the star, seen through a telescope, actually is where it appears to be.

Second, Arago experimented with light beams traveling through glass. He showed that light traveled slower in denser mediums, such as glass or water, and this, in turn, helped support the wave theory of light (as opposed to the particle theory). Since he understood light as consisting of waves, it was assumed that these waves had a uniform speed through the ether, but if the Earth was moving against the ether (as would be the case if it were revolving around the sun) then the ether should impede the speed of light, just as did glass or water. Arago showed, however, that whether the light beam going through the glass was pointed in the direction of the Earth’s supposed movement, or opposite that movement, there was no effect on its speed going through the glass. Moreover, he showed that a light beam pointed toward or away from the Earth’s supposed orbit had the same [refraction](#) in glass as the refraction of starlight in glass.⁴⁹³ Hence, in whatever way he tested the incidence of light, it always showed Earth at rest in the ether. Here was the first confirmed evidence since the Copernican hypothesis arose three centuries prior that science had been far too presumptuous in opting for a heliocentric solar system. In order to stop the hemorrhaging, science had to find the proper tourniquet to save the appearances for a moving Earth.

⁴⁹³ François Arago, “Mémoire sur la vitesse de la lumière, lu à la première classe de l’Institut, le 10 décembre 1810. *Académie des sciences* (Paris). *Comptes Rendus* 36 (1853):38-49. As Arthur Miller describes it: “...Arago covered half of his telescope with an achromatic prism. He found that the aberration angle was independent of whether light passed through the prism...” (*Albert Einstein’s Special Theory of Relativity*, p. 15).

The Experiments of Augustin Fresnel

Enter [Augustin Jean Fresnel](#) (1788-1827). Fresnel worked with Arago on various occasions, and it was left to Fresnel, the more famous of the two, to explain Arago's results by retaining the moving Earth model. Both Arago and Fresnel were advocates of the wave theory of light, and Arago asked Fresnel if it would be possible to explain the results of his starlight experiment by the wave theory. Fresnel came up with an ingenious answer and explained it to Arago in a letter dated 1818.⁴⁹⁴ He postulated that there was no effect on the incidence of starlight because the ether through which it traveled was being "dragged," at least partially, by the glass of the telescope. Because ether was understood to permeate all substances, Fresnel hypothesized that there was a certain amount of ether trapped within the glass, and this amount of ether would be denser than, and independent from, the ether in the surrounding air. The key to understanding this theory is that Fresnel held that the ether outside the glass was immobile. As the glass moved with the Earth's assumed movement and against the immobile ether outside, the glass would "drag" its trapped ether with it. Thus Fresnel conveniently concluded that Arago couldn't detect any difference in the speed of light because the glass in his experiment was dragging the ether just enough in the opposite direction to the Earth's movement so as to mask the Earth's speed of 30 km/sec through the immobile ether.⁴⁹⁵

To understand the rationalization of Fresnel's "drag" to explain Arago's results, let's use an example. We have two telescopes, one hollow and one filled with glass. Both telescopes are viewing the same

⁴⁹⁴ "Lettre d'Augustin Fresnel à François Arago sur l'influence du mouvement terrestre dans quelques phénomènes d'optique," *Annales de chimie et de physique* 9 (1818): 57-66, 286. Reprinted in *Oeuvres Complètes*. Paris: Imprimerie impériale, 1866-1870, vol. 2, pp. 627-636.

⁴⁹⁵ As van der Kamp states: "...an omnipresent Fresnel drag caused by an at least 30 km/sec ether wind in all transparent materials, whether water, glass, perspex, champagne, or castor oil. However, no observer at rest on the Earth's surface can measure this drag as such. Only a supposed 'change' in that drag becomes visible by setting these substances in motion relative to such an observer" (*De Labore Solis*, p. 45). Note that scientists in Fresnel's day were using the term "immobile ether" due to the fact that they believed the Earth was moving through an immobile ether rather than the ether moving against an immobile Earth. The two environments will, in fact, produce the same results, but to avoid any implications of admitting to a fixed Earth, the scientists of this period invariably describe it as an "immobile ether." Some current scientists do the same. For example, Stephen Marinov, whose experiments show an ether-drift of 279-327 km/sec, declares that the Earth is moving through it toward the midpoint of the constellations Virgo, Hydra and Libra. Marinov's calculations are very close to those of Dayton Miller's 1925 interferometer experiments, which registered the Earth's movement at 208 km/sec, but toward Draco. See footnotes later in this volume concerning Dayton Miller's experiments for explanation of this ether-drift in respect of Geocentrism.

star. Will each telescope measure the same aberration (bending) of the starlight? One would think that, since light bends appreciably more in glass, that the glass telescope should show considerably more bending of the starlight compared to the hollow telescope, just as when we put a pencil in a glass of water and notice the pencil appear to bend in the water. (We would notice the same bending if we put half of the pencil in a glass cube).⁴⁹⁶ But as we will see shortly, all such telescopic views of stars will show no more bending of starlight in the glass telescope than in the hollow telescope. There is something about the incidence of starlight received on the Earth that causes this strange phenomenon. As we will see, the natural and least complicated answer for this phenomenon is that Earth is not moving, and since the stars, although moving, are so very far away, the angle of incidence of their light will be virtually the same on one side of the Earth as on the other, that is, it will always be straight overhead and thus cause no refraction or diffraction through our air telescope as opposed to our glass telescopes.

Once again, how did Fresnel explain this phenomenon using the model of an Earth moving at least 30km/sec around the sun and against the incidence of starlight? As noted above, he claimed that the glass telescope had a certain amount of ether contained within it that was denser than the ether outside.⁴⁹⁷ When the starlight enters the glass telescope, the extra ether, by using the Earth's movement, had the ability to "drag" the starlight sufficiently enough away from the immobile ether in the air to make the light within the glass appear to equal the speed of the starlight in the hollow telescope. Incidentally, glass could perform this feat, according to Fresnel, because the light entering it was understood as a wave, whereas if light were composed of particles, Fresnel's theory would not work.

By this clever manipulation of something he couldn't even detect (i.e., the ether) and a nature of light he hadn't even proven (i.e., exclusively waves), Fresnel helped science avoid having to entertain a non-moving Earth as the most likely answer to Arago's puzzling findings. Obviously, to those of honest persuasion, Fresnel's explanation appears to be a little too convenient, especially since he arrived at his solution without any physical experimentation; rather, he merely postulated various assumptions just so he and Arago could escape the

⁴⁹⁶ This bending is described by Snell's law of refraction, which is the relationship between the angles of incidence and refraction, and the indices of refraction of two mediums. The formula is $n_i \times \text{sine}(\theta_i) = n_r \times \text{sine}(\theta_r)$, where θ_i = the angle of incidence; θ_r = the angle of refraction; n_i = the index of refraction of the incident medium; n_r = the index of refraction of the refractive medium.

⁴⁹⁷ Fresnel held that the ether density in the transparent medium (i.e., glass) was proportional to the square of the medium's index of refraction. As such, the ether inside the glass moving through the ether in the air, will move with a fraction [$f = 1 - 1/\eta^2$] of that ether in the air's velocity.

geocentric implications that were haunting them and the rest of the science community. As one heliocentrist seeking to soften the blow states:

It is possible generally to prove how Fresnel's theory entails that not a single optical observation will enable us to decide whether the direction in which one sees a star has been changed by aberration. By means of aberration we can hence not decide whether the Earth is moving or rather the star: only that one of the two must be moving with respect to the other can be established. Fresnel's theory is hence a step in the direction of the theory of relativity.⁴⁹⁸

Although "Relativity" theory would eventually be called to make an unprecedented rescue for Copernicanism, as this saga progresses we will see that it, too, offers no satisfactory escape from Arago or the other stellar aberration experiments that would be performed in the coming years. One problem led to another, and, in light of these intricate experiments, there would be no peace for those resting on the laurels of Copernicus and Kepler. Obviously, in order to add some legitimacy to Fresnel's hypothesis, another experiment had to be devised.⁴⁹⁹

⁴⁹⁸ J. D. ver der Walls, *Ober den wereldether*, p. 78. Cited in *De Labore Solis*, p. 34.

⁴⁹⁹ Mathematically, Fresnel claimed that ether "drags" the light in the glass telescope in accord with the equation: $c = (1 - 1/\eta^2)v$, where c is the speed of light, η is the refractive index of the medium, and v is the velocity of 30 km/sec of Earth's supposed orbit; or more simply $f = 1 - 1/\eta^2$ where f is the "Fresnel drag" and η is the refractive index of the medium. This is described in Fresnel's paper, *Ann. De Chimie*, 17:180 that he wrote in 1821. Please note that our criticism of Fresnel's "drag" theory does not necessarily mean we deny that ether has the ability to drag light. We are critiquing the rather convenient formula Fresnel derived to mask a motionless Earth. In any case, in 1828, and with a more refined view in 1839, Augustine Cauchy, following the work of Claude Navier, postulated that the ether has the same inertia in each medium, but different elastic properties. The ratio of the elastic constant (p) to the measure of a substance's density (Δ) is equal to the speed of light squared (c^2). Fresnel used this ratio and proposed that when the glass plate moves through the ether, it sweeps up ether and obtains a new density. The velocity of the glass plate with respect to its internal ether will be different with respect to the external ether. Although the velocity and density of the internal ether changes, the total mass of the ether must remain the same. Because of the refractive index of light (η), the velocity of light in the moving glass plate is to be subtracted from the velocity of the ether impeded through the plate. The velocity of light, as measured by an observer at rest in the frame of the moving plate is added to the velocity of the plate through the same frame. In 1845 George Stokes (1819-1903), objecting to the notion that a massive body such as the Earth could move through the ether without disturbing it, advocated that stellar aberration was caused by the Earth dragging along all of the ether near its surface as it rotates, which he coined "the ethersphere," and which theory Michelson "revered above all others" (Lloyd Swenson, *The Ethereal Ether*, p. 24). Stokes' view was diametrically opposed to Fresnel's concept that ether was immobile and only partially dragged by such things as glass. Fresnel held to an immobile ether to accommodate his "transverse" wave theory of light (as opposed to longitudinal waves), a theory he more or less was forced to adopt to

explain light polarization. As such, Fresnel required a solid ether (as opposed to a fluid ether) to produce the forces needed to oppose the distortions caused by transverse waves. In further developments, in 1849 Stokes suggested that the ether was not dragged by the moving glass plate, but that the ether within the plate was compacted. In his work with light diffraction around opaque bodies and light diffraction in the sky, he showed that the vibration of ether particles is at right angles to the plane of polarization. The same did not hold for crystals, so Stokes reversed Cauchy's hypothesis, making the elastic properties of ether the same in all materials, but allowing the inertia to be anisotropic. In the end, Stokes' ether behaves as a rigid solid for high-frequency oscillations of light but as a fluid for the slow moving celestial bodies. In 1867, further experiments forced Stokes to withdraw his theory. (cf., G. G. Stokes, "On the Aberration of Light," *Philosophical Magazine* 27, pp. 9-15, 1845; "On Fresnel's Theory of the Aberration of Light," *Philosophical Magazine* 28, pp. 76-81, 1846; "On the Constitution of the Luminiferous Ether Viewed with Reference to the Phenomenon of the Aberration of Light," *Philosophical Magazine* 29, pp. 6-10, 1846; "On the Constitution of the Luminiferous Ether," *Philosophical Magazine* 32, pp. 343-349, 1848). In the same year, Joseph Boussinesq proposed that, rather than ether having differing inertia in various media, it is the same in all locations but interacts in various ways depending on the type of materials. By 1888 R. T. Glazebrook revived Cauchy's wave theory and combined it with Stokes' anisotropic ether to agree with Stokes' 1867 experiment. In the early 1870s, Wilhelm Veltmann objected to Fresnel's theory due to the differences in refractive indexes for the various colors of light, which would require Fresnel's drag to be different for each color ("Über die Fortpflanzung des Lichtes in bewegten Medien," *Annalen der Physik* 150, pp. 497-535, 1873). In 1912, Larmor held that the ether itself could not be detected, only its consequent effects. In 1951 Paul Dirac suggested that physics needed a revised ether theory, as did Louis de Broglie in 1971.

The Experiments of Armand Fizeau

Enter [Armand Fizeau](#) (1821-1896), the very person whose experiments Einstein mentions as a major cause for concern and the impetus for his invention of Relativity theory.⁵⁰⁰ Fizeau needed to prove Fresnel's "drag" theory so as to have a physical, not merely theoretical/mathematical, answer for Arago's results. So horrible were the implications of Arago's experiments that counter-experiments such as the one Fizeau would soon undertake were described as an attempt to "find the ether" or "discover the nature of the ether" rather than what was truly at stake – finding out whether the Earth was really moving or not. Scientists strictly avoided language suggesting that the Earth could be motionless, for the system of Copernicus, although without a shred of proof, was the holy grail of the science establishment, and no one dare trespass its domain. Whereas the nineteenth century experimenters often camouflaged their worries that Earth could be standing still in space by referring instead to a "motionless ether," twentieth century commentators after Einstein consistently avoided the geocentric implications of the nineteenth century experiments by turning the issue into one of "searching in vain for" or "abandoning" the elusive ether once they found out that the experiments invariably led to the possibility of a motionless Earth. To get a feeling of this sentiment, the reader need only recall the words of Edwin Hubble we cited earlier: to Hubble, finding the Earth in the center of the universe would be "intolerable" and a "horror" that "must be rejected."

As for Fizeau, his initial experiments found that the speed of light through glass varied with the color of the light, something for which neither Arago nor Fresnel tested. This meant, of course, that the ether would have to be reacting differently with various colors of light; or, there was a different amount of ether trapped in the glass for each particular color, options which seemed far-fetched. Fizeau proposed the hypothesis that the ether possessed elasticity, and varying degrees of elasticity would cause various reactions with light. Thus, Fizeau set out to test the constitution of the ether in 1851. He sent two parallel light beams in opposite directions through [tubes of water](#) in which the water was flowing rapidly. In this way, one beam would be traveling with the flow of water, the other against the flow. When the light beams meet back at the receiving plate, the one traveling against the flow of water

⁵⁰⁰ That Fizeau probably knew the stakes for failure would require a rejection of Copernican cosmology is supported by the fact that he worked very closely with Jean Foucault (1819-1868), famous for the Foucault Pendulum which hangs in many of today's scientific museums as the so-called "proof" of the Earth's rotation. Fizeau and Foucault had worked together a few years before 1851 in demonstrating that the speed of light could be determined in the laboratory, not just astronomically. Fizeau became famous for his "toothed-wheel" experiment to measure light's speed. We will investigate the Foucault Pendulum in later chapters.

should arrive later, just as a person swimming against a water current will need more time to complete a journey than one swimming with the current. As the light beams arrive at the final destination at different times, the peaks and troughs of their wavelengths will not be in synch, which will then cause light and dark fringe markings to appear on the receiving plate. Water was the perfect medium to make such a test. Since light's speed in water is two-thirds of the upper limit it is said to travel in a vacuum, the water-medium would provide enough margin from the upper limit so that one could easily notice whether its speed was changed. As it turned out, the interference fringes showed a difference in the arrival times of the two beams and this result was said to support the Fresnel "drag" formula.⁵⁰¹

Although Fizeau helped give credibility to Fresnel's "drag" theory, he did little to establish that the Earth was moving through the ether. If we on Earth are moving through ether, then the speed of the light in the water tube will be increased with the speed of the Earth's motion (30 km/sec). But the outcome was quite different than what Fizeau expected. The speed of light was not a sum of the velocity of the light added to the velocity of the Earth. Rather, the only effect on the speed of light Fizeau found was that which was induced by the water's refractive index. This was quite a dilemma. On the one hand, it showed that light was affected by a medium (i.e., water), but on the other hand, the light was not being affected by the medium of ether, that is, its speed was not increased or decreased as it went through the ether. The logical conclusion of this experiment, of course, is that it was presumptuous of Fizeau to assume the Earth was moving through the ether, since a fixed-Earth can easily account for why the light was not affected by the ether but only by the water (i.e., by refraction).⁵⁰²

In order to escape this problem, Fizeau postulated that, as the water flowed, it would drag *only some* of the ether with it, and thus make the light move against *only some* of the ether, which would then appear as an alteration in the speed of the light in the water, and which, coincidentally, would equal the refractive index of the water, and which

⁵⁰¹ Armand Hippolyte Louis Fizeau, "Sur les hypotheses relatives à l'éther lumineux, et sur une expérience qui paraît démontrer que le mouvement des corps change la vitesse à laquelle la lumière se propage dans leur intérieur" *Académie des sciences* (Paris), *Comptes Rendus* 33 (1851):349-355. In mathematical terms, Fizeau's formula to determine the interference fringes is $\delta = 4\eta^2 f\nu L/\lambda c$ where λ is the wavelength of light; ν is the speed of the water; L is the length of the tubing; f is the drag factor; η the refractive index; and c the speed of light. In the experiment Fizeau calculated a difference of $\delta = 0.23$ interference lines, which implies an empirical drag factor $f = 0.48$. Since the theoretical drag is calculated from $f = 1 - 1/\eta^2$, which is 0.435, there is a margin of error of approximately 10% between Fresnel and Fizeau.

⁵⁰² In Fizeau's experiment no distinction is made between the ether in the water and the ether in the air, since both light beams are traveling through water, and it is only those light beams which are subsequently measured.

would also equal the Fresnel “drag” coefficient. Thus it seemed that Fizeau’s experiment supported Fresnel’s experiment, at least that’s the way it was interpreted. In reality, both Fresnel and Fizeau, without any proof whatsoever, were already discounting a fixed-Earth as a viable solution to the unexpected results of their experiments.⁵⁰³

Despite this apparent “solution,” there was still an open question: Would Fizeau’s use of water to drag ether and impede the speed of light prove to be true for starlight? Of course, the reason the question of starlight would surface is not because starlight is intrinsically different than laboratory light, but only because, underneath it all, the parties involved were quite cognizant of the cosmic implications of testing starlight, that is, because of the star’s immense distance from Earth it had the ability to determine whether the Earth was really moving or not. Arago had already demonstrated this fact to the science community back in 1810 when he observed no change in the incidence of starlight over the course of a year’s observations, but the Copernicans were determined to put these results in the category of “interesting, but unconvincing.”

⁵⁰³ In a repeat of Fizeau’s experiment in 1884, Michelson and Morley agreed with Fizeau’s results, which they published in 1886. They wrote: “...the result of this work is therefore that the result announced by Fizeau is essentially correct: and that the luminiferous ether is entirely unaffected by the motion of the matter which it permeates” (“Influence of Motion of the Medium on the Velocity of Light,” *American Journal of Science*, 31, p. 386, 1886). But they would later withdraw their support after their 1887 interferometer experiment.

The Experiments of George Airy and James Bradley

Twenty years after Fizeau's experiment, [George Biddell Airy](#) would perform his own water-tube experiment, which, to his utter surprise, would confirm Arago's results – that Earth was standing still in space. Although Fresnel temporarily saved the world from having to scuttle the Copernican theory, we will see that the nature of Airy's experiment left Einstein with no choice but the fantastic postulations of Relativity theory to answer Airy's results.

George Airy belonged to the exclusive Astronomer Royal of England, thus he was a well-respected scientist and had quite a reputation and audience for his endeavors. But Airy was an avowed heliocentrist just as Einstein, so it is not Airy's position as an esteemed scientist for which we make reference to his work, but precisely because of his failure to prove his cherished view of cosmology. Airy was quite certain, at least before he did his experiment, that his water-filled telescope would prove that the Earth revolved around the sun. Hence, he was quite surprised at his "failure."

Here's how "Airy's failure" transpired. Airy knew from Arago that: (1) light's speed was slower in a solid transparent medium than in air; (2) that any movement ascribed to the Earth did not affect the speed of light, and (3) that Fresnel's explanation of Arago's experiment was that the glass plate "dragged" the ether and thus acted independently of ether in the air. Hence, Airy, by merely enhancing the procedures of those before him, had the idea of using a source of light outside Earth, namely starlight, and directing it through different mediums to see if the light was affected.

James Bradley

Before we see what Airy's experiment did in the battle for whether the Earth was fixed in space, it would be beneficial to know a little of the history about the nature of starlight. As early as 1640 the astronomer Giovanni Pieroni observed that various stars shifted their position in the sky during the year. As we noted earlier, Francesco Rinuccini brought this evidence to Galileo's attention in 1641, but Galileo was unimpressed. Three decades later, in 1669, [Robert Hooke](#) noticed the same kind of shifting for one star in particular, named *Gamma Draconis*. Since everyone from the time of Copernicus had been looking for physical evidence of a moving Earth, Hooke actually thought he had discovered the first parallax as proof. Almost another thirty years later (1694), [John Flamsteed](#) observed the same kind of shifting in the star Polaris. Another thirty years later, [James Bradley](#) (d. 1762) set out to determine whether Hooke's observations were, indeed, a parallax of *Gamma Draconis*. During the years of 1725-1728 he noticed that during the course of a year the star inscribed a small ellipse in its path, almost

the same as a parallax would make. In the heliocentric system, parallax is understood as a one-to-one correspondence between Earth's annual revolution and the star's annual ellipse, but Bradley noticed that the star's ellipse was not following this particular pattern.⁵⁰⁴

At this point, astronomical science was still waiting for a confirmed parallax of any star, since no one had ever measured one. A confirmed measurement of parallax would not be made until more than a century later by Friedrich Bessel in 1838. So Bradley, reasoning that *Gamma Draconis* was too far away to register a parallax, found another explanation, and it was rather an ingenious one. He theorized that the star's annual ellipse was being formed because the speed of light was finite.⁵⁰⁵ That is, the star wasn't actually moving in the sky; rather, its light, moving at a finite speed, was hitting a moving Earth, an Earth that

⁵⁰⁴ Parallax, as measured from Earth, is understood as the measure of the apparent movement of a star against more distant stars that do not move. There are about 700 stars in our sky that are close enough to Earth and far enough from background stars in order to form a parallax. In the heliocentric system, which Bradley was using, a star's parallax is measured by using the Earth's orbit. At each point on the Earth's path, a star with parallax will appear on the opposite side of the Earth's orbit in the star's ellipse. For example, in the heliocentric system, if the Earth is at twelve o'clock in its orbit the star will be at six o'clock in its ellipse; if Earth is at three o'clock, the star will be at nine o'clock. In stellar aberration, the Earth and the star will not be on opposite sides of their respective ellipses. So, if the Earth is at twelve o'clock in its orbit, the star will also be at twelve o'clock in its ellipse. Bradley noticed that *Gamma Draconis* was following the stellar aberration pattern, not the parallax pattern, since it was behind the parallax pattern by at least three months. Bradley found a 20.47° angle of aberration. As we will see later, stellar aberration can also be explained by the geocentric model, since in that model the stars are centered on the sun and partake of the sun's annual movement around Earth, and thus stellar aberration will occur in exactly the same proportions as in the heliocentric system. Incidentally, Bradley also discovered that *Gamma Draconis* traced out an additional smaller ellipse in the course of 18.6 years. The heliocentric explanation for this ellipse is that the moon, since its orbital precession rotates around Earth once every 18.6 years, is altering the Earth's axial spin (otherwise known as nutation). This explanation fails, however, since it would require each star to have the same 18.6 year ellipse as *Gamma Draconis*. The geocentric explanation for the 18.6 year ellipse is that, as the universe rotates around Earth, a slight uneven mass distribution causes a small precession of the universe of 18.6 years, which is part of a larger precession of 25,800 years (the heliocentric system has a 25,800-year precession of the Earth's axial rotation). These dual precessions, in conjunction with the stars that move within those precessions in a specified elliptical path depending on their distance from Earth, distance from the North Star (Polaris), and their mass, will create a specified ellipse for each star, as seen from Earth.

⁵⁰⁵ Up until this time, the only one who had suggested that light had a finite speed was Ole Römer in 1670 as he was observing the variations between two successive eclipses of Io, one of Jupiter's moons. The eclipse is the shortest in duration when, in the heliocentric system, Earth is moving toward Jupiter, and longest in duration when Earth is moving away. As we will see later, this same phenomena can be explained by the geocentric model since in that model, Jupiter, revolving around the sun, is moving toward and away from a fixed Earth in the same proportions as in the heliocentric system.

for six months was moving toward the star, and in the next six months was moving away from the star. While the Earth moved toward the star, the star's light would hit the Earth sooner, but while the Earth moved away, the light would hit it later. Bradley reasoned that, if light's speed was infinite, there would be no such effect, but since it is finite, these back-and-forth movements of the Earth would translate into seeing the star move in an ellipse in the sky over the course of a year. This explanation was a welcome relief for the heliocentric view, since until Bradley, no one, including Galileo who died in 1642, had supplied any real evidence that the Earth could be revolving around the sun.⁵⁰⁶ The only "evidence" Galileo's contemporaries provided was that of analogy, that is, because he saw moons revolving around Jupiter through his telescope he conjectured that smaller bodies (such as the Earth) had to revolve around larger bodies (such as the sun). As one author put it, in Galileo's day, "the telescope did not prove the validity of Copernicus' conceptual scheme. But it did provide an immensely effective weapon for the battle. It was not proof, but it was propaganda."⁵⁰⁷ Thus, the Arago/Fresnel/Fizeau affair was more or less an interlude until someone would come along and either prove or disprove Bradley's hypothesis.

Back to George Airy

Enter George Airy. As ingenious as Bradley's answer was to the ellipse formed by *Gamma Draconis*, so was Airy's experiment to prove it right or wrong. Accepting that light's speed was finite, Airy had to figure out some way of determining whether the light from a star was affected by Earth's supposed motion. Whereas Bradley used only one kind of telescope, Airy had the ingenious idea of using a second telescope filled with water. Since Arago/Fresnel/Fizeau had already shown that light's speed was slowed by glass or water, Airy assumed that if a telescope was filled with water then the starlight coming through the water should be slower than it would be in air, and thus bend the starlight outward toward the upper side of the telescope and away from the eyepiece (just as we see light bent when we put a pencil in water). In order to compensate for the outward bending of the starlight, Airy

⁵⁰⁶ As one modern astronomer presumptuously concluded: "The discovery of this aberration was the first experimental proof that the earth has a yearly motion and that Copernicus was right" (A. Pannekoek, *A History of Astronomy*, New York, Interscience Publishers, 1961; originally published in 1951 under the Dutch title: *De Groei van ons Wereld*, cited in *The Biblical Astronomer*, Vol. 3, No. 64, 1993).

⁵⁰⁷ Thomas Kuhn, *The Copernican Revolution*, New York, Random House, 1959, p. 224. Kuhn adds: "The opposition took varied forms. A few of Galileo's more fanatical opponents refused even to look through the new instrument...Others...claimed...they were apparitions caused by the telescope itself. Most of Galileo's opponents behaved more rationally. Like Bellarmine, they agreed that the phenomena were in the sky but denied that they proved Galileo's contentions. In this, of course, they were quite right. Though the telescope argued much, it proved nothing" (*ibid.*, p. 226).

assumed he would have to tilt his water-filled telescope just a little more toward the lower end of the star so that its light would hit his eyepiece directly rather than hitting the side of the telescope.

We would do the same thing, for example, if we were carrying a drinking glass while we were running through a rainstorm. In order to catch the raindrops so that they hit the bottom and not the side of the drinking glass, we must tilt the drinking glass forward a bit in order to compensate for our running speed. Another example that illustrates this principle rather well is the task of dropping a drop of water into a test tube from an eye-dropper. If the test tube is mounted so that it stands straight up on a rotating disc, and one tries to drop a drop of water into the test tube as it comes around, the drop will invariably hit the inside of the test tube. One must tilt the test tube slightly in the direction of the rotation in order to allow the drop to hit the bottom of the test tube. Light, because it reacts as if it were a substance, moves in a similar fashion to the drop of water (only it moves much faster than rain and eye droppers, and thus the effects are much more subtle).

Although Airy had suspected the outcome prior to the actual experiment, indeed, he soon discovered that he was not required to tilt his water-filled telescope toward the star to any greater degree than his air-filled telescope. These results indicated that Earth wasn't moving, since if there is no additional adjustment necessary for a water-filled telescope toward the direction of the starlight, it means the starlight is coming into both telescopes at the same angle and speed, that is, directly overhead. If Earth were moving, then a water-filled telescope would have to be tilted toward the starlight a little more acutely than an air-filled telescope. This is so for two related reasons: (1) in the heliocentric model, the Earth is moving sufficiently against the incidence of distant starlight upon it, and thus the water-filled telescope would not be able to catch all of the starlight in the slower medium of water. It would have to be tilted slightly ahead of the air-filled telescope to make up for light's slower speed in water; and (2) since the starlight is coming from outside Earth's ether environment, then one cannot readily explain Airy's failure by saying that the denser medium (i.e., water as opposed to air) carried a higher or lower amount of ether, as Fresnel had claimed. Starlight seemed to be unaffected by the ether, or any medium, since Airy proved that its light was coming to Earth at one specified angle and speed.⁵⁰⁸

⁵⁰⁸ George B. Airy, "On a supposed alteration in the amount of astronomical aberration of light produced by the passage of light through a considerable thickness of refracting medium" (Proceedings of the Royal Society, London, 1871, pp. 35-39). As Arthur Miller describes it by means of a diagram: "Consider, in the geocentric system, a water-filled telescope whose line of sight to a star is normal to the direction of the star's velocity relative to the Earth which is $-v/N^2$ (according to Fresnel's hypothesis). The law of sines yields $\sin \delta' = v/cN$. Since the starlight is refracted on entering the water then δ' is not the aberration angle. Using Snel's law to relate v and δ' , i.e., $\sin \delta = N \sin \delta'$, we obtain $\sin \delta = v/c$. This derivation is based on the ones of Veltmann (1873), Lorentz (1886) and Drude (1900). The notion of seeking deviations from stellar

At this juncture we should also mention the fact that Bradley's appeal to a 20.5" arc in the star's movement as being due to a 30 km/sec revolution of the Earth around the sun assumes that the sun is a fixed object. Without taking the sun as fixed, Bradley would not be able to detect any aberration in *Gamma Draconis*. But according to modern cosmology, no object in the sky is fixed, and thus Bradley's theory is nullified on that count alone. Otherwise, the sun is at rest or Relativity is wrong.

As we noted earlier, Arago had already postulated in theory what Airy found by experiment, and he wrote a paper about it in 1839, and thus the science establishment should have anticipated Airy's results.⁵⁰⁹ Moreover, Guiseppe Boscovich (1766) and Augustin Fresnel (1818) had already suggested testing Arago's hypothesis by a water-filled telescope. In Airy's experiment, the water-filled telescope would be analogous to Arago's glass plate (or the glass-filled telescope example we offered earlier), since both would make light travel at a slower speed than in air. Fresnel, being a firm believer that the Earth revolved around the sun in an ether medium, explained Arago's results by claiming that the glass plate trapped the ether and thus dragged it and the light, giving the appearance of the bending of light in the glass plate. In fact, it could be said that the plate dragged the ether equal to the Earth's supposed movement around the sun.⁵¹⁰ But it was not easy for Fresnel to explain Airy's failure, because Airy found that, with respect to two different telescopic mediums, there is no additional drag of starlight by the ether surrounding Earth. In other words, if Earth were moving, it would be moving against the ether, and thus the ether wind, as it were, would be expected to push the starlight past the telescope. Airy showed that the ether was not pushing the starlight faster through one medium than the other since both of his telescopes could view the star from the same angle. Fresnel would also not be able to explain Airy's failure if he claimed that the ether is moving with the Earth instead of against the Earth, otherwise he would have no more explanation why, in Arago's case, light is diffracted more in a glass plate than in air. Science was in a

aberration in air by using a water-filled telescope had been suggested by Boscovich in 1766, and was mentioned by Fresnel (1818), who predicted no change because this experiment was equivalent to Arago's. Airy (1871) carried out the experiment and found no change in the aberration angle" (*Albert Einstein's Special Theory of Relativity*, p. 19).

⁵⁰⁹ *Comptes Rendus de l' Académie des Sciences*, 8, 326, 1839.

⁵¹⁰ In other words, the angle of refraction in the glass plate will equal the arc seconds Earth moves in its angular journey around the sun, since both are formed by Earth's movement through the ether. Incidentally, although we emphasize that Fresnel was a "heliocentrist," Arago and Airy were also heliocentrists, and thus "Airy's failure" is a failure for heliocentrism.

bind once again. Unless Airy's experiment could be answered, the world was about to stand still in space, both literally and figuratively.⁵¹¹

⁵¹¹ Aware of the acute dilemma for heliocentrism that Airy's experiment presents, an example of how modern science seeks to rationalize its results is noted in the explanation of S. Tolansky on the art of telescope viewing: "If the Fresnel drag coefficient be introduced into the calculation of the aberration, there emerges the fact that the aberration is the same with or without water in the telescope. Thus, conversely, Airy's negative result confirms the validity of the Fresnel coefficient" (*An Introduction to Interferometry*, New York, John Wiley and sons, 1973, p. 98, cited in *De Labore Solis*, p. 35). What Tolansky didn't tell his students is that if the Fresnel coefficient is NOT used for both telescopes, they would both still produce the same aberration, and thus the Fresnel drag becomes superfluous, except for those trying to save the appearances for heliocentrism. As van der Kamp notes, "...the drag coefficient cannot be dragged into court to vindicate Copernicus" (*ibid.*, p. 36). Another objection comes from Wolfgang Pauli. With his typical pungency Pauli wrote in 1958: "The Airy experiment, as seen from the rest system of the observer (Earth), therefore only demonstrates the (relativistically) trivial fact that for a zero angle of incidence (normal incidence) the angle of refraction is zero, too" (Wolfgang Pauli, *Theory of Relativity*, translated by G. Field, New York, Dover Publications, 1958, p. 114). Apparently, Einstein did not share the same casualness about Airy that Pauli did. Pauli seems to have both forgotten that neither the "observer" nor the "Earth" are "at rest" in the Copernican system, and that a "zero" value to both incidence and refraction is precisely the reason Airy's experiment is so important, since, given the same incidence of starlight in both telescopes, only the velocity of the Earth would have made the starlight hit the side of the telescope. Moreover, it would be rather difficult for Relativity to explain stellar aberration on the basis of the limited speed of light, since without ether, Relativity must understand light as a scalar phenomenon (i.e., it has a speed but no definite direction, and thus the speed is everywhere the same), not a vector (i.e., a definite speed in a definite direction). As such, Relativity will see the star rotate rather than exhibit an aberration.

The Experiment of Martinus Hoek

Just three years before Airy's entrance, Martinus Hoek, an astronomer at Utrecht, performed another type of experiment, but one that had demonstrated the same results as Airy, namely, that the Earth was not moving.⁵¹² In 1868 he created a variation of Fizeau's experiment in order to test the nature of light. Up until this time, the use of laboratory light by Fresnel and Fizeau had yet to be answered, and thus the Copernicans retained hope that they could protect their cherished view. In his apparatus, Hoek split a light beam so that it would travel in opposite directions, and he had the beams travel through both water and air. Again, since light travels slower in water, then as the light beams meet back at the starting point, one beam will come in slower than the other and cause what is known as "fringes" on the receiving plate, that is, alternating light and dark patterns. Working on the idea that as the Earth moved through space it was doing so against the ether, which creates friction against the light (and which Fresnel described as a "drag"), if the apparatus of Hoek's experiment were turned in the direction of the Earth's movement, and then subsequently perpendicular to it, there would not only be fringes but a noticeable *shifting* of the fringes. As C. Møller describes it:

A measurement of the velocity of light in transparent substances seems to offer a new possibility for a determination of the absolute motion of the earth. An experiment of this kind was performed in 1868 by Hoek who used an interferometer arrangement of...a monochromatic light ray from a source of light...divided by a (weakly silver-coated) glass plate....Even if the whole apparatus were at rest in the ether, such an arrangement would give rise to interference fringes in the telescope, since the slope of the mirrors cannot possibly be adjusted so accurately that two rays 1 and 2 which focus on the same point in the telescope have traversed a path exactly the same optical length. However, if the whole apparatus has a velocity v with respect to the ether, this will cause an extra phase difference ΔF between the rays 1 and 2...⁵¹³

⁵¹² Martinus Hoek, "Détermination de la vitesse avec laquelle est entraînée une onde lumineuse traversant un milieu en mouvement," *Arch. Neerl.*, 1868, 3, pp. 180-185; and 1869, 4, pp. 443-450. Prior to Hoek, M. Babinet performed another form of the experiment, and a few years later Ernst Klinkerfues had also performed similar experiments to Hoek's with the same results (*Die Aberration der Fixsterne nach der Wellentheorie*. Leipzig: Von Quandt and Händel, 1867), cited in *The Proceedings of the Royal Society*, vol. xx, 1871, pp. 35-39. Mascart makes reference to Babinet in M. Mascart, "Sur les modifications qu'éprouve la lumière par suite du mouvement de la source lumineuse et du mouvement de l'observateur," *Annales Scientifiques de l'École Normale Supérieure* Sér. 2, 1, 1872, pp. 157-214.

⁵¹³ C. Møller, *The Theory of Relativity*, Oxford, Clarendon Press, p. 17.

To his surprise, Hoek noticed no significant difference in the fringes, at least not in accord with an Earth supposedly moving 30 km/sec. The obvious interpretation of this experiment is that Earth is not moving through the ether. Similar to Airy's eventual experience, we could call this experiment: "Hoek's failure."⁵¹⁴

The Experiment of Eleuthère Mascart

Still another experiment was performed just one year after Airy's findings to test for the motion of the Earth. In 1872 Eleuthère Elie Nicolas Mascart devised an experiment in which he could detect the motion of the Earth through ether by measuring the rotation of the plane of polarization of light propagated along the axis of a quartz crystal. Polarization is a phenomenon of white light, which propagates along the axis of forward movement at many different angles but is reduced to just one angle. Polarizers are filters containing long-chain polymer molecules that are oriented in one specific position. As such, the incident light vibrating in the same plane as the polymer molecules is the only light absorbed, while light vibrating at right angles to the plane is passed through the polarizer. Mascart set up the experiment so that if the Earth were passing through the ether at the expected clip of 30 km/sec, then the light's plane of polarization would be affected. Mascart found no such results. His experiment was just another indication that Earth was not moving.

Prior to these events, in 1809 [Carl Gauss](#) had published his *Theoria Motus Corporum Caelestium*, which predicted the orbit of the asteroid Ceres, thus suggesting (as Galileo once did with Jupiter's moons), that smaller bodies rotated around larger ones. Further claims to have proof of the Copernican system were advanced by [Frederich Bessel](#) in 1838 as he finally discovered the long-awaited stellar parallax.

⁵¹⁴ Heliocentric explanations to Hoek's result are quite presumptuous. As Walter van der Kamp states: "It is not difficult to see the conclusion that Hoek thought he could draw from this null result. Whatever speed v of the ether relative to the Earth we have decided to believe in, be it a few centimeters or many kilometers – we cannot demonstrate that speed" (*De Labore Solis*, p. 32). That is, Hoek and his colleagues just assumed the Earth was moving at 30 km/sec without ever demonstrating such movement. Van der Kamp also chides heliocentrist J. D. van der Waals' comments on Hoek's experiment. Van der Waals writes: "To perform the test he did not have to take great pains to give the whole apparatus a sufficient speed... The Earth by means of her rotation and annual orbit around the sun, provided a speed that was vastly greater than could have been obtained in any other manner... If the ether carrying the light moves with a velocity w ... then we find $w = v(\eta^2 - 1/\eta^2)$, which is exactly the ether velocity according to Fresnel" (*Ober den wereldether*, Haarlem, Erven Bohn, 1929, pp. 81). Of course, as van der Kamp points out, this only begs the question, for if the Earth is not moving, then $v = 0$, and if that is the case then $w = 0$, and we have mathematical formulas that don't amount to anything.

In 1843, John C. Adams, and later Urbain Leverrier in 1846, used Newtonian mechanics to predict the orbit of Neptune. In 1851 [Jean Foucault](#) published his experiments on the pendulum. All of these events were leaning toward the adoption of the Copernican system, yet none of them provided any real proof. Since no one, including Copernicus and Galileo, had ever proved that the Earth was moving, then as long as there was the possibility of explaining these experiments by assuming a non-moving Earth, then modern science was at a crossroads. But the pressure was mounting against the Copernicans, for Hoek countered Fresnel, and Airy countered Bradley and Fizeau, and Mascart put the icing on the cake. So now, even though the science community was silent, geocentrism was the unconquerable foe of the Copernicans. As van der Kamp observes:

Hence it can be argued that Fresnel's theory holds for transparent substances moving through an ether at rest in that ether. Which is tantamount to saying that Hoek and Airy (observer and substance both at rest), Fizeau (observer at rest, substance in motion) and Michelson and Morley, all five of them have with one accord been vainly striving to show that the Earth is not at rest.

The 1881 Michelson Experiment

So now we have a better picture of the circumstances that led to the Michelson-Morley experiments. To save the world from having to “scuttle the Copernican theory,” just a few years after George Airy’s experiment, [Albert Michelson](#) invented a somewhat sophisticated piece of equipment to test Airy’s results.⁵¹⁵ The interferometer he assembled was similar to Hoek’s, but it was built a little better and was more accurate, yet it was very sensitive to vibration and heat, and therefore its results could be thrown off a bit. Nevertheless, if the Earth were moving through ether this machine was designed to detect it. The idea was to split a light beam into two beams and send them in perpendicular directions, which beams are then reflected back and recombined on a photographic plate. The distances traveled by the beams are not the same, thus the waves from the two beams will not be in synch, producing a pattern of [light and dark fringes](#) after they recombine. These fringes prove that the principle behind the interferometer indeed works, since non-synchronous light waves will produce fringes. Identical to Hoek’s experiment, Michelson’s procedure was to turn, slightly and periodically, the table on which the interferometer rested. The speeds of the two beams with respect to the ether will thus change, and so will the times taken for the beams to recombine. Because troughs and crests of the light waves would not match up the same as in a non-rotating table, the original fringes would shift in their pattern of bright and dark lines. As Charles Lane Poor puts it:

Light waves vibrate, or follow one another, at a rate of about six hundred thousand billion a second; and it was this interval of time that Michelson used to measure the relative retardations of the waves traveling in the two directions....In any one fixed position of the apparatus...an observed retardation of one ray over the other might be the indication merely of instrumental errors of adjustment, errors in the length of arms, in the alignment of the mirrors, or in the direction of the instrument as a whole. But if the apparatus be rotated so that the arms take

⁵¹⁵ Another impetus for Michelson was James Clerk Maxwell. After establishing his electromagnetic theory of light, Maxwell designed and performed an experiment for the purpose of detecting the Earth’s motion through the ether. Not surprisingly, Maxwell found a null result. He reported the results to Stokes in 1864 and readied a paper for publication in the *Proceeding of the Royal Society*. Stokes informed Maxwell that Arago had already performed such an experiment and that Fresnel accounted for Arago’s null results by means of the “drag” formula. Maxwell then withdrew his paper. Shortly before his death, Maxwell posted an article for the ninth edition of the *Encyclopedia Britannica* under the title “Ether,” in which he argued that the only way to measure the Earth’s velocity in the ether is to observe variations in the velocity of light traveling between two mirrors. A letter Maxwell wrote to astronomer D. P. Todd (1855-1939) inquiring about these issues was published in *Nature*, which was the very letter that inspired Michelson to take up Maxwell’s challenge.

up various positions with respect to the [ether] drift, then the retardations due to instrumental errors will be eliminated, and that due to the drift will show up.⁵¹⁶

The first interferometer trial was in 1881. After Michelson drew up plans for the device and submitted them to a company in Berlin for construction, [Alexander Graham Bell](#), famous for the invention of the telephone, provided the needed funds. Michelson had not met Edward Morley as yet and thus he worked alone. Lo and behold, when Michelson performed the experiment he did not see a significant shifting of fringes, at least not those he was expecting. Using a 600 nanometer wavelength of light, Michelson expected to see fringe shifts (or, as he called them, “displacement of the interference bands”) of at least 0.04 of a fringe width. The 0.04 figure corresponds to an Earth moving at 30 km/sec around the sun. If this was combined with what Michelson believed was the solar system’s apparent movement toward the constellation Hercules, the fringes should have shifted on the order of 0.10 of a fringe width. But Michelson didn’t see any fringe shifting close to either value. He writes:

The interpretation of these results is that there is no displacement of the interference bands. The result of the hypothesis of a stationary ether is thus shown to be incorrect, and the necessary conclusion follows that the hypothesis is erroneous. This conclusion directly contradicts the explanation of aberration which has been hitherto generally accepted, and which presupposes that the Earth moves through the ether, the latter remaining at rest.⁵¹⁷

Notice, for future reference, that Michelson did not say there was *no* displacement of the interference bands, but that the “*interpretation* of

⁵¹⁶ Charles Lane Poor, *Gravitation versus Relativity*, New York: G. P. Putnam’s Sons, Knickerbocker Press, 1922, pp. 14, 16.

⁵¹⁷ Albert A. Michelson, “The relative motion of the Earth and the Luminiferous ether,” *The American Journal of Science*, Vol. 3, No. 22, 1881, p. 128. As regards the Earth’s supposed movement around the sun, in 1881 Michelson expected a fringe shift of 0.04 but got 0.02. In 1882, Hendrik Lorentz examined Michelson’s results and determined them “to be in error,” and Michelson conceded to this in 1887. As Arthur Miller writes: “...Lorentz pointed out a calculation error committed by Michelson in his data analysis: Michelson had calculated the time required for the light ray to traverse the interferometer arm normal to the direction of the Earth’s motion to be $2l/c$, instead of $2l/c + lv^2/c^3$ [the exact result was $(2l/c)(1/\sqrt{1-v^2/c^2})$]. The extra term, Lorentz continued, reduced the calculated fringe shift by a factor of two, thereby placing any effect beyond Michelson’s experimental accuracy; so Michelson’s data ruled out neither Fresnel’s theory nor the hybrid theory composed of elements of Fresnel’s and Stokes’ theories” (Arthur Miller, *Albert Einstein’s Special Theory of Relativity*, p. 23). Despite the discrepancy pointed out by Lorentz, the fact is that the 1881 results, although a little exaggerated, show the same principle results as the 1887 experiment – there is an ether drift, regardless of how small it is.

these results is that there is no displacement of the interference bands.” Obviously, if you are looking for fringe shifting on the order of 0.10 but you get results that are 0.040 of a fringe width, you would be inclined to say there was “no displacement of the interference bands.”

Notably, in the above quote from his 1881 experiment Michelson makes reference to the same “stellar aberration” phenomenon over which Einstein would later be concerned. This shows that Michelson had his heart set on confirming or denying the experimental results of George Airy and Armand Fizeau. Unfortunately for the heliocentrists, Michelson only confirmed Airy’s results and, in the process, overturned the hypothesis of Fresnel and Fizeau, who claimed that the Earth moved through space at 30 km/sec and was doing so against the ether, which creates friction against a light beam pointed in the same direction, and which would thus decrease the speed of the light beam.

Michelson’s experiment, as he says himself, also overturned the idea that “the Earth moves through the ether.” On the surface, this is a rather amazing admission by Michelson. Perhaps he did not realize what he had said; nevertheless, there it is. He did not say that the ether did not exist; rather, he said Earth does not move through the ether. Fresnel had “presupposed” that the Earth moved at 30 km/sec through ether, but Michelson’s results said no. At this point Michelson was being very honest with his own results. Let us remember Michelson’s original interpretation as we move on in this saga.

The 1887 Michelson-Morley Experiment

Perhaps Michelson was so astounded at his 1881 results and the interpretation he was forced to admit (i.e., “This conclusion directly contradicts...[the idea] which presupposes that the Earth moves through the ether”) that he had to do the test again just to make sure he could convince himself to believe what his own eyes were showing him, and to reassure every other concerned physicist that this experiment was not a fluke. After attending a series of lectures by [William Thomson](#) (aka Lord Kelvin) in 1884, Michelson’s interest in redoing the 1881 interferometer experiment was sparked. Michelson secured financial aid from the Bache Fund of the National Academy of Sciences. This involvement reveals that many influential people were intently anticipating the desired results. Michelson, and his newfound partner Edward Morley, created a new instrument for the occasion, which was much more accurate and not so easily upset by environmental factors. (People walking at a distance of 100 yards from the interferometer disturbed Michelson’s 1881 apparatus). Michelson and Morley increased by eightfold the length the light had to travel in contrast to the 1881 machinery. They even put their new interferometer in a pool of mercury so that it could be rotated without causing any vibration. They secured an adequate basement facility at Case Western University. With these improved conditions, Michelson and Morley now expected to see an interference pattern equal to 0.40 of a fringe width as opposed to the 0.1 he expected in 1881. As they rotated the apparatus in the mercury pool in increments of $1/16^{\text{th}}$ of a turn, their assistant would write down the fringe shift values Michelson calibrated from graduated markings in the eyepiece. To his surprise, Michelson did not find what he expected. The experiment was repeated a number of times, but regardless of location, season, elevation or orientation of instruments Michelson found the results were the same as the 1881 experiment, within a reasonable margin of error. As Michelson records it:

Considering the motion of the Earth in its orbit only, this displacement should be $2D v^2/V^2 = 2D \times 10^{-8}$. The distance D was about eleven meters, or 2×10^7 wavelengths of yellow light; hence, the displacement to be expected was 0.4 fringe. The actual displacement was certainly less than the twentieth part of this, and probably less than the fortieth part. But since the displacement is proportional to the square of the velocity, the relative velocity of the Earth and the ether is probably less than one-sixth the Earth’s orbital velocity, and certainly less than one-fourth.⁵¹⁸

⁵¹⁸ A. A. Michelson and E. W. Morley, “On the Relative Motion of the Earth and the Luminiferous Ether,” Art. xxxvi, *The American Journal of Science*, eds. James D and Edward S. Dana, No. 203, vol. xxxiv, November 1887, p. 341. As one textbook calculates it: “ $\Delta t - \Delta t' = (l_1 + l_2) v^2/c^3$. Now we take $v = 3.0 \times 10^4$ m/s, the speed of the

In a letter to [Lord Rayleigh](#) (aka John William Strutt), he states it more simply:

The experiments on relative motion of earth and ether have been completed and the result is decidedly negative. The expected deviation of the interference fringes from the zero should have been 0.40 of a fringe – the maximum displacement was 0.02 and the average much less than 0.01 – and then not in the right place. As displacement is proportional to squares of the relative velocities it follows that if the ether does slip past [the Earth] the relative velocity is less than one sixth of the Earth's velocity.⁵¹⁹

So here we see that, although his 1881 results would not allow anyone to “presuppose that the Earth was moving through the ether,” it is just this that Michelson is presupposing as his bedrock datum to interpret his 1887 experiment. This shows how ingrained the idea of an orbiting Earth was in the minds of scientists only two centuries from the Galileo affair in the 1600s. It was the foundation from which they interpreted everything in the cosmos. Finding interference patterns of only hundredths of a fringe rather than nearly half a fringe meant that someone had to come up with a convincing explanation, or Michelson and company might have to stop making such grandiose “presuppositions.”⁵²⁰

Earth in its orbit around the Sun. In Michelson and Morley's experiment, the arms l_1 and l_2 were about 11 m long. The time difference would then be about $(22\text{m})(3.0 \times 10^4 \text{ m/s})^2 / (3.0 \times 10^8 \text{ m/s})^3 \approx 7.0 \times 10^{-16} \text{ s}$. For visible light of wavelength $\lambda = 5.5 \times 10^{-7} \text{ m}$, say, the frequency would be $f = c/\lambda = (3.0 \times 10^8 \text{ m/s}) / (5.5 \times 10^{-7} \text{ m}) = 5.5 \times 10^{14} \text{ Hz}$, which means that wave crests pass by a point every $1/(5.5 \times 10^{14} \text{ Hz}) = 1.8 \times 10^{-15} \text{ s}$. Thus, with a time difference of $7.0 \times 10^{-16} \text{ s}$, Michelson and Morley should have noted a movement in the interference pattern of $(7.0 \times 10^{-16} \text{ s}) / (1.8 \times 10^{-15} \text{ s}) = 0.4$ fringe. They could easily have detected this, since their apparatus was capable of observing a fringe shift as small as 0.01 fringe. But they found no significant fringe shift whatever....Never did they observe a significant fringe shift. This ‘null’ result was one of the great puzzles of physics at the end of the nineteenth century” (*Physics: Principles with Applications*, Fourth Edition, Douglas C. Giancoli, New Jersey, Prentice Hall, 1995, p. 749). Notice that the author does not say there was no fringe shift, but that there was no “significant fringe shift.”

⁵¹⁹ Letter dated August 17, 1887, from the Rayleigh Archives, as cited in Dorothy M. Livingston, *The Master of Light: A Biography of Albert A. Michelson*, Charles Scribner, 1973, p. 130.

⁵²⁰ In *The Ethereal Ether*, Loyd Swenson summarizes Michelson's options as: “1. The Earth passes through the ether without appreciable influence; 2. The length of all bodies is altered (equally?) by their motion through ether; 3. The Earth in its motion drags with it the ether even at distances of many thousands of kilometers from its surface” (Austin, University of Texas, 1972, p. 118, cited in *De Labore Solis*, p. 36, parenthetical “equally” included by Michelson). Van der Kamp remarks: “...this lifelong agnostic...Michelson...appears on one issue not in the least agnostic, but as firmly a

Again, as we noted earlier, here was additional evidence, from an even more sophisticated machine specifically designed to vindicate Copernicus, Galileo, Kepler and Newton, yet it failed, miserably failed. Unfortunately, the scientists interpreting Airy, Hoek and Michelson-Morley simply did not want to consider a motionless Earth as even a possible solution to these astounding experiments. They “knew” the Earth revolved around the sun, and thus they set their heart toward finding other solutions to the problem. As Einstein’s biographer describes it:

In the United States Albert Michelson and Edward Morley had performed an experiment which confronted scientists with an appalling choice. Designed to show the existence of the ether, at that time considered essential, it had yielded a null result, leaving science with the alternatives of tossing aside the key which had helped to explain the phenomena of electricity, magnetism, and light *or of deciding that the Earth was not in fact moving at all.*⁵²¹

If they were set on refusing to consider that the Earth was standing still in space, this left them with two more options to explain its results. As Clark records it:

The second was that the ether was carried along by the Earth in its passage through space, a possibility which had already been ruled out to the satisfaction of the scientific community by a number of experiments, notably those of the English astronomer James Bradley. The third solution was that the ether simply did not exist, which to many nineteenth century scientists was equivalent to scrapping current views of light, electricity, and magnetism, and starting again.⁵²²

[Henri Poincaré](#) compared it to a “crisis.”

fundamentalist Copernican believer...There is no place in Michelson’s only partially agnostic tunnel-vision for possibility Number Four [i.e., that Earth is motionless in space]...Yet...a geocentric explanation of the enigmas encountered...stares...any open-minded down-to-Earth scientist in the face when he surveys all those abortive efforts to disqualify it...In Michelson’s heliocentrically preconditioned mind the obvious corollary, a simple straightforward geocentric hypothesis, did not get a chance to rear its unwanted head...Michelson searched for and found those three helpful *ad hoc*s, three pretexts able to ward off a disturbing and unwanted perspective” (*ibid.*, pp. 36-37, 42).

⁵²¹ *Einstein: The Life and Times*, p. 57. Emphasis added.

⁵²² *Einstein: The Life and Times*, p. 110.

Are we about to enter now upon the eve of a second crisis? These principles on which we have built all, are they about to crumble away in their turn? ...Alas...such are the indubitable results of the experiments of Michelson.⁵²³

It is ironic that Poincaré would describe the problem as a “second crisis,” since the context of his paragraph shows that the “first crisis” he has in view is the Copernican revolution. The irony is that the “second crisis” was now bringing science back to admit that it made a wrong decision during the “first crisis.” As the old saying goes: “what goes around comes around.” In essence, the Michelson-Morley experiment trapped science like the proverbial rat in the corner. As we noted earlier, nothing less than the total revamping of physical science could satisfy the demands of these experiments, that is, if a motionless Earth was not considered as an option. As Van der Kamp puts it: “That is to say: nothing less than a premise capable of turning all evidence favoring a geocentric universe into evidence for an a-centric homogenous one will suffice.”⁵²⁴ Eventually this revamping of science would lead to Einstein’s Special Relativity theory, but there were stops along the way to set the stage for his arrival.

⁵²³ Henri Poincaré, “The Principles of Mathematical Physics,” *The Monist*, vol. XV, January 1905, pp. 6, 20.

⁵²⁴ *De Labore Solis*, p. 44. Later he writes: “...astronomy books, misleading as – courtesy of Albert Einstein – their heliocentric illustrations and explanations are, seldom or ever spell out the a-centric concept to which the Copernican revolution has inevitably led” (*ibid.*, p. 112).

The Fitzgerald-Lorentz Contraction Hypothesis

In 1892 [Hendrik Lorentz](#) wrote to Lord Rayleigh and expressed his consternation at the results of the Michelson-Morley experiment:

I am totally at a loss how to solve the contradiction and yet I believe that if Fresnel's wave theory is abandoned, we should have no adequate aberration theory at all...Can there be some point in the theory of Mr. Michelson's experiment which has as yet been overseen [sic].⁵²⁵

We see what is at stake. As Einstein himself would recognize, the Michelson-Morley experiment is not only showing that there is no movement of the Earth against ether, it is denying to the heliocentrists the only explanation available (Fresnel's wave theory) to deal with the results of Airy's failure. If they cannot use Fresnel to answer Airy and the other aberration experiments, then they would have to resign themselves to admitting that the Earth is motionless in space. A solution had to be found. Clark explains what it was:

The only other explanation must surely lie in some perverse feature of the physical world which scientists had not yet suspected, and during the next few years this was sought by three men in particular George Fitzgerald... Hendrik Lorentz ...and Henri Poincare. The Fitzgerald explanation came first. To many it must have seemed that he had strained at a gnat and swallowed an elephant. For while Fitzgerald was unwilling to believe that the velocity of light could remain unaffected by the velocity of its source, he suggested instead that all moving objects were shortened along the axis of their movement. A foot rule moving end forwards would be slightly shorter than a stationary foot rule, and the faster it moved the shorter it would be.⁵²⁶

A November 10, 1894 letter from Lorentz to Fitzgerald shows that the Michelson-Morley experiment was driving them to these positions:

My dear Sir, In his "Aberration Problems" Prof. Oliver Lodge mentioned a hypothesis *which you have imagined in order to*

⁵²⁵ Letter dated August 18, 1892, from the Lorentz microfilm at the Neils Bohr Library, New York, as cited in Dorothy Michelson Livingston's *The Master of Light: A Biography of Albert A. Michelson*, p. 131.

⁵²⁶ *Einstein: The Life and Times*, p. 110.

account for the negative result of Mr. Michelson's experiment."⁵²⁷

"Imagination," indeed. Fitzgerald revealed this imaginative "hypothesis" to [Oliver Lodge](#) in early 1892 on a visit to Liverpool. He told him the following:

Well, the only way out of it that I can see is that the equality of paths must be inaccurate; the block of stone must be distorted, put out of shape by its motion...the stone would have to shorten in the direction of motion and swell out in the other two directions.⁵²⁸

On May 27, 1892, Lodge made it known to the public that "Professor Fitzgerald has suggested *a way out of the difficulty* by supposing the size of bodies to be a function of their velocity through the ether."⁵²⁹ Lodge proceeded to give an example of Fitzgerald's hypothesis. According to Lodge, a length of 8,000 miles (approximately the diameter of the Earth), would have to be shortened only 3 inches in order to account for the null result of the Michelson-Morley experiment.⁵³⁰ On the one hand, since 3 inches seemed to be such a trivial length, it wouldn't take much to adjust the mathematics to make it fit into the physical measurements. On the other hand, since 3 inches is minute compared to 8,000 miles, it shows how precise the Michelson-Morley experiment really was, and it was a preciseness that simply would not go away, being that the same ratios showed up in virtually every interferometer experiment performed for the next several decades.

In any case, we see clear evidence that, in refusing to accept the possibility of a motionless Earth, yet provide an answer to the "null" results of the Michelson-Morley experiment, physics was now opting for the absurd hypothesis that matter was mysteriously altered as it moved. Fitzgerald was forced to this position since he had to answer why, if Earth was moving 18.5 miles per second, that a light beam discharged in the same direction as Earth's movement arrived at its destination at the same time that a beam discharged perpendicular to the Earth's movement

⁵²⁷ Draft copy in Algemeen Rijksarchief, The Hague, published by Stephen G. Brush, in *Note on the History of the Fitzgerald-Lorentz Contraction*, *Isis*, 58:231, 1967; emphasis added; cited in Holton's *The Thematic Origin of Scientific Thought*, pp. 328, 364.

⁵²⁸ Archived in "Report of Activities of the Physical Society," *Nature*, vol. XLVI (1891), p. 165, as cited in Dorothy Michelson Livingston, *The Master of Light*, p. 132.

⁵²⁹ Oliver Lodge, "On the Present State of Knowledge of the Connection between Ether and Matter: A Historical Summary," *Nature*, 46:164-165, 1892; emphasis added, cited in Holton's *Thematic Origins of Scientific Thought*, pp. 328, 364.

⁵³⁰ As reported to the *Royal Society of London, Philosophical Transactions* under the title "Aberration Problems," vol. 184-A (1893), pp. 749-750.

arrived at the same destination. Michelson's equipment was sensitive enough to calibrate an ether wind speed of 1 mile per hour, which was obviously 18.5 times more sensitive than the Earth was supposedly moving through it.⁵³¹

To be consistent with his newfound hypothesis, Fitzgerald was required to posit that the test instruments must adjust in the same way, altering their length as they were turned into the direction of the Earth's movement through the ether. Incidentally, this "contraction" solution would also be employed to explain stellar aberration, since Fitzgerald could claim that as the Earth traveled at 66,000 mph the telescope would alter in length and thus receive starlight in altered forms: one form for when the Earth was receding from the star and another when it was moving toward the star.

The reader is reminded that, despite Airy's discovery that there is no difference in the incidence of starlight on two respective telescopes (thereby discounting stellar aberration as a proof for heliocentrism), stellar aberration is still a natural phenomenon that always occurs when one views a star over the course of several months. As such, it must be explained. For those who accepted an ether-filled space between Earth and the stars, appealing to Fresnel "drag" was one attempt to explain stellar aberration, and the Fitzgerald "contraction" was another. In both cases the Earth is understood to be moving through motionless ether. But as we have seen earlier, Fresnel's theory is discounted by Airy's "failure," which leaves only Fitzgerald's theory and the geocentric model to explain stellar aberration. In the geocentric model the ether moves against a fixed-Earth, and the aberration angle of the star is a consequence of the ether's pressure on the travel of light, which is opposed to Fresnel's model that ascribed aberration to the relative motion of the star. The other option was Fitzgerald's "contraction" theory. But as Clark shows, initially it was not well received:

For some years this explanation appeared to be little more than a plausible trick. 'I have been rather laughed at for my view over here, Fitzgerald wrote to Lorentz from Dublin in 1894.'"⁵³²

But when Fitzgerald learned of Lorentz's support for the hypothesis, he suddenly changed his tune and wrote these words:

⁵³¹ In fact, based on light's wavelength of 5×10^{-7} meters, the Michelson-Morley experiment was supposed to be sensitive enough to detect not only the revolution of the Earth around the sun (18.5 mps; 66,600 mph; or 30 km/s) but also the rotation of the Earth (300 m/s at the longitude of the experiment). As history shows, it detected neither.

⁵³² *Einstein: The Life and Times*, p. 111.

My dear Sir, I have been preaching and lecturing on the doctrine that Michelson's experiment proves, and is one of the only ways of proving, that the length of a body depends on how it is moving through the ether...Now that I hear you as an advocate and authority I shall begin to jeer at others for holding any other view.⁵³³

Obviously, Fitzgerald was “laughed at” because his solution seemed all too convenient. As physicist Dennis Sciama notes about similar acts of desperation in science:

No one would take this theory seriously, of course. One reason for this, no doubt, would be the obviously *ad hoc* and, indeed, ludicrous appearance of the theory. But the fundamental reason for objecting to the theory is that the demons cannot be observed *except through the very phenomenon they were invented to explain*. The introduction of the demon thus adds nothing to what we know already.⁵³⁴

Although Fitzgerald was “laughed at” for proposing his contraction theory, he probably would have been scorned or put in a straight jacket if he had proposed that the Earth was standing still in space. By now, Copernicanism was so much a part of the fabric of life that any *ad hoc* explanation of the Michelson-Morley experiment would probably have been accepted if people knew the alternative was believing in a motionless Earth. But the alternative was never told to them, for Fitzgerald, *et al.*, did not want the common man even thinking about that possibility. In fact, once he received Lorentz's agreement, Fitzgerald considered the contraction hypothesis as scientific dogma, and he decided to do the “laughing” at others who disagreed with him. All that was needed now was to package Fitzgerald's idea in scientific language and a mathematical formula since this would give it an air of prestige and intelligence. This task was left to [Henrick Lorentz](#). As he puts it:

The first example of this kind is Michelson's well-known interference experiment, the negative result of which has led Fitzgerald and myself to the conclusion that the dimensions of solid bodies are slightly altered by their motion through the ether.⁵³⁵

⁵³³ Holton, *Thematic Origins*, p. 331.

⁵³⁴ Dennis Sciama, *The Unity of the Universe*, New York: Anchor Books, Doubleday, 1961, p. 103, emphasis his.

⁵³⁵ H. A. Lorentz, “Electromagnetic Phenomena in a System Moving with any Velocity Less Than that of Light,” in *The Principle of Relativity*, translated by W. Perrett and G. B. Jeffery from the 1923 first edition, Dover Publications, 1952, p. 11. In another paper Lorentz adds: “For if we now understand by S_1 and S_2 not, as formerly, two systems of

As Ronald Clark describes it:

Lorentz had been among the first to postulate the electron, the negatively charged particle whose existence had finally been proved by J. J. Thomson at Cambridge. It now seemed to him that such a contraction could well be a direct result of electromagnetic forces produced when a body with its electrical charges was moved through the ether. These would disturb the equilibrium of the body, and its particles would assume new relative distances from one another. The result would be a change in the shape of the body, which would become flattened in the direction of its movement.... Lorentz's invocation of electromagnetism thus brought a whiff of sanity into the game. Here at least was a credible explanation of how a foot rule in motion could be of a different length from the foot rule at rest.⁵³⁶

Being a firm believer in Relativity, Clark describes Lorentz's solution as a "whiff of sanity," but for those of us who are not as inclined toward such *ad hoc* speculations, the "whiff" is more of a stench. Lorentz, by an explanation heretofore unimagined in common-sense science, is saying that matter shrinks when it moves, which is due to some internal structural change its atoms undergo by some unexplained electrical forces. Of course, Lorentz would have to exclude light from this natural contraction, and thus the full title of his 1904 paper became "Electromagnetic Phenomena in a System Moving *with Any Velocity*

charged particles, but two systems of molecules – the second at rest and the first moving with a velocity v in the direction of the axis x – between the dimensions of which the relationship subsists as previously stated; and if we assume that in both systems the x components of the forces are the same, while the y and z components differ from one another by the factor $\sqrt{1 - v^2/c^2}$, then it is clear that the forces in S_1 will be in equilibrium whenever they are so in S_2 . If therefore S_2 is the state of equilibrium of a solid body at rest, then the molecules in S_1 have precisely those positions in which they can persist under the influence of translation. The displacement would naturally bring about this disposition of the molecules of its own accord, and thus effect a shortening in the direction of motion in the proportion of 1 to $\sqrt{1 - v^2/c^2}$ " (H. A. Lorentz, "Michelson's Interference Experiment," in *The Principle of Relativity*, translated by W. Perrett and G. B. Jeffery from the 1923 first edition, Dover Publications, 1952, p. 7).

⁵³⁶ *Ibid.*, p. 111. Lorentz happened upon these equations in a paper by Woldemar Voigt written in 1887 on the Doppler effect (Über das Dopplersche Prinzip, Nachr. Ges. Wiss. Göttingen). Voigt came to his view by analyzing differential equations for oscillations in an incompressible elastic medium, which led to a set of transformation equations to support his theory of the converging or diverging of spherical forces. It wasn't until many years later that Lorentz acknowledged Voigt's primary work.

Less than that of Light.”⁵³⁷ As Louis Essen describes Lorentz’s hypothesis:

...moving particles gave rise to a magnetic field, thus disturbing the equilibrium of the forces binding the particles together and causing the length of any moving object to be reduced. The requirements of the electro-magnetic theory made it necessary for time to change in a similar way, and these assumptions led to the Lorentz transformations.⁵³⁸

Lorentz had no proof of this explanation, but it certainly was a relief to a science community that up to this point was totally stymied by the results of optical experiments showing that the Earth was standing still in space. At least Lorentz’s explanation was a much easier pill to swallow than bringing the human race back to pre-Copernican days. In essence, Lorentz created a formula that allowed the Earth’s rest to appear as motion, and no one was the wiser.

The completely *ad hoc* nature of the contraction hypothesis is made obvious by the diametrically opposed views of Fitzgerald and Lorentz. Herbert Dingle astutely pointed out that, although Fitzgerald’s proposal has been commonly reported as a *contraction* of the longitudinal arm of the interferometer (the arm pointing toward the direction of the Earth’s movement), Fitzgerald originally proposed that the width, not the length, of the longitudinal arm increased, and that the length of the transverse arm also increased (the arm at a right angle to the movement of the Earth). The only account of Fitzgerald’s original proposal is included in [Oliver Lodge’s](#) book *The Ether of Space*, an account that Lodge obtained by a personal interview with Fitzgerald.⁵³⁹

⁵³⁷ From the English version in the Proceedings of the Academy of Sciences of Amsterdam, 6, 1904, cited in *The Principle of Relativity*, p. 9, emphasis added.

⁵³⁸ Louis Essen, *The Special Theory of Relativity – A Critical Analysis*, p. 4.

⁵³⁹ Dingle’s charge is confirmed as Lodge quotes Fitzgerald speaking of “when a block of matter is moving through the ether of space its cohesive forces across the line of motion are diminished, and consequently in that direction it expands.” Lodge records it as follows: “Hence, although there may be some way of getting round Mr. Michelson’s experiment, there is no obvious way; and if the true conclusion be not that the ether near the earth is stagnant, it must lead to some other important and unknown fact. ¶ That fact has now come clearly to light. It was first suggested by the late Prof. G. F. FitzGerald, of Trinity College, Dublin, while sitting in my study at Liverpool and discussing the matter with me. The suggestion bore the impress of truth from the first. It independently occurred also to Prof. H. A. Lorentz, of Leiden, into whose theory it completely fits, and who has brilliantly worked it into his system. It may be explained briefly thus...¶ ‘Atoms of matter are charged; and cohesion is a residual electric attraction. So when a block of matter is moving through the ether of space its cohesive forces across the line of motion are diminished, and consequently in that direction it expands, by an amount proportioned to the square of aberration magnitude. ¶ A light journey, to and fro, across the path of a relatively moving medium is slightly quicker than the same journey, to and fro, along. But if the journeys are planned or set out on a

Lorentz changed the phenomenon to one having the longitudinal arm decrease in length and the transverse arm decrease in width, and it was this version of the “contraction” that became the pair’s best answer to the Michelson-Morley experiment.⁵⁴⁰ As such, Lorentz writes:

We are therefore led to suppose that the influence of a translation on the dimensions (of the separate electrons and of a ponderable body as a whole) *is confined to those that have the direction of the motion*, these becoming β times smaller than they are in the state of rest.⁵⁴¹

Lorentz was still in a bind, however. His 1886 paper “On the Influence of the Earth’s Motion on Luminiferous Phenomena” dealing with the optical effects of bodies in motion, stated that it was possible for ether to be partially dragged. But Lorentz’s theory of how electrons moved, which he introduced in the early 1890s, was based on the idea of an immobile ether. In this view, ether was understood to be totally separate from matter, and consequently, the only way ether and matter could interact was through infinitesimal charged particles, such as electrons, which generate electrical and magnetic fields in the ether, and which fields, in turn, exert forces on the electrons. Lorentz faced the very difficult task of explaining, based on his electron/immobile-ether theory, why optical experiments, such as those performed by Michelson-Morley, Hoek, Fresnel, Fizeau, Airy, *et al.*, failed to detect the Earth moving through an immobile ether. Fresnel had worked on the basis of “dragged” ether, and thus Lorentz had to derive Fresnel’s formula from his new theory of electrons and electromagnetic propagation without admitting to an ether drag. His solution? In 1892, Lorentz claimed that

block of matter, they do not remain quite the same when it is conveyed through space; the journey across the direction of motion becomes longer than the other journey, as we have just seen. And the extra distance compensates or neutralizes the extra speed; so that light takes the same time for both” (Oliver Lodge, *The Ether of Space*, New York and London, Harper and Brothers, 1909, p. 69. Dingle says that it appears on pp. 65-66).

⁵⁴⁰ Herbert Dingle, *Science at the Crossroads*, p. 163. Dingle adds: “Lodge’s account, it is true, does not make it perfectly clear whether this is his explanation of the effect or FitzGerald’s, but since he leaves no doubt that the fundamental idea was FitzGerald’s, it is unlikely that he would change it without saying so, and in that case there is no such thing as the ‘FitzGerald contraction’; it is the FitzGerald expansion, for, according to this explanation, it is not the longitudinal arm that is contracted but the transverse arm that is lengthened – the effect on the fringes, of course, being the same” (*ibid.*, 163-164).

⁵⁴¹ “Electromagnetic Phenomena in a System Moving with any Velocity Less Than that of Light,” in *The Principle of Relativity: A Collection of Original Memoirs on the Special and General Theory of Relativity* by H. A. Lorentz, A. Einstein, H. Minkowski and H. Weyl, translated by W. Perrett and G. B. Jeffery from the original 1923 edition, Dover Publications, 1952, p. 28.

the electromagnetic waves, not the ether, are partially dragged. Thus, the ether can remain immobile and the Earth can remain in motion, but while the Earth moves it brings some of the electromagnetic waves with it.⁵⁴² As one can see, the shell game of modern science continued and Lorentz became its premier magician, all in an effort to avoid having to admit to the audience the possibility that the Earth was standing still in space.

The issue was further obfuscated when physicists began creating different responses to explain the “contraction” solution. At one point Lorentz held: “Yes, it is as real as anything we can observe,” to which [Sir Arthur Eddington](#) retorted, “We say it contracts; but length is not a property of the rod; it is a relation between the rod and the observer.”⁵⁴³ At another time Eddington said: “The shortening of the moving rod is true, but it is not *really true*.”⁵⁴⁴ In one of his more sober moments, however, he added: “...it was like the adventures of Gulliver in

⁵⁴² As Arthur Miller explains it, hoping to give it some respectability: “Lorentz (1886) used Huygens’ principle and Fresnel’s hypothesis to deduce the velocity of light that traversed a medium of refractive index N that was at rest where the source could have been either on the Earth or in the ether [which] explained Arago’s experiment and an equivalent one by George Biddell Airy. Lorentz continued (1886), by noting that from the viewpoint of the geocentric system we could say that ‘the waves are entrained by the ether’ according to the amount $-v/N^2$. For consistency with the nomenclature of the time Lorentz defined v_r as the velocity of the ‘relative ray’ and c/N as the velocity of the ‘absolute ray.’ For example, in order to view the light from a fixed star, a telescope, or a system of aligned slits, at rest on the Earth had to be oriented in the direction of the relative ray because the relative ray was the direction in which energy was transported....On the other hand, an observer at rest in the ether measured the velocity of the light that was propagating through the medium at rest on the moving Earth to be $c' = u_r + v$...Lorentz noted that the ether-fixed observer could interpret [$c' = u_r + v$] as the ‘entrainment of the light waves by the ponderable matter’ (*Albert Einstein’s Special Theory of Relativity*, pp. 19-20). Of course, even Einstein could see through this hodgepodge of *ad hoc* explanations, politely calling them “asymmetries which do not appear to be inherent in the phenomena,” in his 1905 *Annalen der Physik* article. In the end, Lorentz was forced to admit: “Briefly, everything occurs as if the Earth were at rest, and the relative rays were the absolute rays” (*ibid.*, p. 20).

⁵⁴³ *Einstein: The Life and Times*, p. 120.

⁵⁴⁴ Arthur S. Eddington, *The Nature of the Physical World*, New York, MacMillian Company and Cambridge University Press, 1929, pp. 33-34, emphasis his. Other confusing statements include Wolfgang Pauli’s: “It therefore follows that the Lorentz contraction is not a property of a single rod taken by itself, but a reciprocal relation between two such rods moving relatively to each other, and this relation is in principle observable” (Wolfgang Pauli, *Theory of Relativity*, Dover Publications, 1958, pp. 12-13); and Herman Minkowski’s: “This hypothesis sounds extremely fantastical, for the contraction is not to be looked upon as a consequence of resistances in the ether, or anything of that kind, but simply as a gift from above, – as an accompanying circumstance of the circumstance of motion” (“Space and Time,” in *The Principle of Relativity: A Collection of Original Memoirs on the Special and General Theory of Relativity* by H. A. Lorentz, A. Einstein, H. Minkowski and H. Weyl, translated by W. Perrett and G. B. Jeffery from the original 1923 edition, Dover Publications, 1952, p. 81).

Lilliputland and Alice's adventures in Wonderland.”⁵⁴⁵ Albert Michelson didn't buy it either. To him the Lorentz solution was artificial, mainly because the so-called contraction was independent of the elastic property inherent in the interferometer itself, as in, for example, the resilience of a tennis ball returning to its original shape after it is struck. He writes of Lorentz's proposal: “Such a conclusion seems so improbable that one is inclined to return to the hypothesis of Fresnel and try to reconcile in some other way the ‘negative result’ [of the Michelson-Morley experiment].”⁵⁴⁶ At other points Lorentz admitted he was uncertain. In 1904 he stated:

It need hardly be said that the present theory is put forward with all due reserve. Though it seems to me that it can account for all well-established facts, it leads to some consequences that cannot as yet be put to the test of experiment. One of these is that the result of Michelson's experiment must remain negative...⁵⁴⁷

The experiments of which I have spoken are not the only reason for which a new examination of the problems connected with the motion of the Earth is desirable...in order to explain Michelson's negative result, the introduction of a new hypothesis has been required...Surely this course of inventing special hypotheses for each new experimental result is somewhat artificial. It would be more satisfactory if it were possible to show by means of certain fundamental assumptions...⁵⁴⁸

⁵⁴⁵ *Relativity, Time and Reality*, Harold Nordenson, London, 1969, p. 153. Jaffe adds: “To anyone accustomed to thinking in terms of the then recognizable truths of physics, Fitzgerald's theory was a sort of Mad Hatter's deduction” (Bernard Jaffe, *Michelson and the Speed of Light*, p. 92).

⁵⁴⁶ Albert Michelson, “Relative Motion of the Earth and the Ether,” *American Journal of Science*, vol. III, June 1897, p. 478.

⁵⁴⁷ “Electromagnetic Phenomena in a System Moving with any Velocity Less Than that of Light,” in *The Principle of Relativity: A Collection of Original Memoirs on the Special and General Theory of Relativity* by H. A. Lorentz, A. Einstein, H. Minkowski and H. Weyl, translated by W. Perrett and G. B. Jeffery from the original 1923 edition, Dover Publications, 1952, p. 29).

⁵⁴⁸ As cited in *Thematic Origins of Scientific Thought*, Gerald Holton, Harvard University Press, 1988, p. 323. C. Møller adds this criticism: “The contraction hypothesis looks rather startling at first sight, but, as stressed by Lorentz, it is impossible to escape from it as long as the conception of an absolute unmovable ether is maintained...The difficulty was only that the presupposition that the particles are held together exclusively by electric forces could scarcely be assumed to be satisfied in the real substances. In particular it was difficult to imagine how the charge of a single electron could be held together, unless strong attractive forces of non-electrical nature were active inside the electron. If one therefore assumes that the contraction formula [$l = l_0(1-v^2/c^2)^{1/2}$] is valid also for a single electron, as was actually assume by Lorentz,

Notice that Lorentz is concerned with “problems connected with the motion of the Earth,” which tells us that the fear of being forced to accept the “unthinkable” immobile Earth was the basis upon which his *ad hoc* solution was determined. Reading between the lines we know that Lorentz was concerned with the fact that, if he could not come up with a convincing explanation to Michelson-Morley, he and the rest of the world would be in for a great embarrassment. Undaunted, Lorentz put the contraction theory of Fitzgerald into a mathematical formula and the equation eventually became world famous. Known as the “Lorentz Transformation,” it is still employed by many scientists today for almost any problem having to do with dismissing the possibility that Earth is motionless in space.⁵⁴⁹

this must be regarded as a pure hypothesis which cannot be based on the principles of the electron theory alone” (C. Møller, *The Theory of Relativity*, p. 29).

⁵⁴⁹ As noted, Fitzgerald was the first to hypothesize length contraction in 1889, but Lorentz improved the concept and applied the mathematics. After Michelson had published the results of his first experiment in the *American Journal of Science* in 1881, Lorentz published its interpretation in 1886 (“Over den invloed, dien de beweging der aarde op de lichtverschijnselen uitoefent,” Koninklijke Akademie van Wetenschappen (Amsterdam); *Afdeeling Natuurkunde, Verslagen en Mededeelingen* 2 (1885-86): 297-372. Reprinted: “De l’influence du mouvement de la terre sur les phénomènes lumineux,” *Archives néerlandaises des sciences exactes et naturelles* 21 (1887): 103-176). Of note, Michelson and Morley stated in their 1887 paper that Lorentz’s idea of a partially dragged ether “also fails.” Six years later (1892) Lorentz published his papers on Maxwell’s work (“La theorie electromagnétique de Maxwell et son application aux corps mouvants,” *Archives néerlandaises des sciences exactes et naturelles* 25 (1892): 363-552; and “De relatieve beweging van de aarde en den ether” reprinted as “The Relative Motion of the Earth and the Ether”). Both the 1886 and 1892 papers postulated the “contraction” concept. In 1895 Lorentz wrote a more definitive paper titled: “Versuch einer Theorie der elektrischen und optischen Erscheinungen in bewegten Koerpern,” in which he elaborated on the ether-based contraction hypothesis. As noted above, Lorentz invented his equation based on Woldemar Voigt’s equation explaining the Doppler-effect for converging spherical forces (Über das Dopplersche Prinzip, *Nachr. Ges. Wiss. Göttingen*, 1887). Voigt’s equations are based on division by $1 - (v/c)^2$ where v is the velocity of convergence. As Wolfgang Pauli describes it: “As long ago as 1887, in a paper still written from the point of view of the elastic-solid theory of light, Voigt mentioned that it was mathematically convenient to introduce a local time t' into a moving reference system...These remarks, however, remained completely unnoticed, and a similar transformation was not again suggested until 1892 and 1895, when H. A. Lorentz published his fundamental papers on the subject” (*Theory of Relativity*, W. Pauli, translated by G. Field, New York, Dover Publications, 1958, p. 1). Pauli also notes that “Larmor who, as early as 1900, set up the formulae now generally known as the Lorentz transformation, and who thus considered a change also in the time scale (*ibid.*, p. 2, citing J. J. Larmor, *Ether and Matter*, Cambridge, 1900, pp. 167-177). Poincaré made revisions to Lorentz’s work, and Lorentz gave a final proposal in 1905, but both agreed that the method of arriving at the formula was by “groping” for it. As Ives reports: “Lorentz arrived at his formulae by a process of invention and accretion; Poincaré arrived at his by giving Lorentz’s equations a mathematical going-over to make them fit his principle of relativity” (“Revisions of the Lorentz Transformations,” *Proceedings of the American Philosophical Society*, vol. 95, no. 2,

That Lorentz knew the implications of the problem is noted in a personal letter he wrote to Einstein in 1915. As we noted previously (but is well worth repeating), as he began to feel the effects of the centerless universe into which Einstein's Relativity put the human race, in a moment of seeming desperation Lorentz appeals to the same entity upon which Isaac Newton and his "action-at-a-distance" concept found himself depending – a divine being that could hold it all together. Lorentz writes:

April, 1951, p. 131). The formula said that length (L) had to be multiplied by the square root of 1 minus the square of: the velocity of the object divided by the speed of light, $L = L \times \sqrt{1 - (v/c)^2}$. In this formula, v = the speed of the Earth at 300,000 kilometers per second around the sun, while "c" is the speed of light in a vacuum, presently held at 299,792,459 meters per second. The resulting value in the Lorentz transformation is then $0.999999995 = L$. In the original equations, $[(1 - v^2/c^2)^{1/2}]^n + 1$ was used for rods shortened when in uniform motion; $[(1 - v^2/c^2)^{1/2}]^n$ was used for rods shortened in the direction of motion, and later, $[(1 - v^2/c^2)^{1/2}]^{1-n}$ was used for clocks slowing in uniform motion. Lorentz admitted that the value of "n" was "the origin of all our difficulties," since there was no experimental data to verify its assumed value (See Ives, "Light Signals on Moving Bodies as Measured by Transported Rods and Clocks" *Journal of the Optical Society of America*, July 1937, vol. 27, p. 263). Interestingly enough, the Lorentz-Fitzgerald contraction matched the Fresnel-Fizeau drag coefficient, but this, of course, is only to be expected, since both solutions are merely mathematical gap-fillers for an effect that neither group of scientists understood. Not surprisingly, Max Born cites the notorious controversy leaving open whether the contraction is "real" or only "apparent." A more recent advocate of Lorentz admits:

Since the first steps of relativity, Lorentz-Fitzgerald contraction has been the subject of a debate which is not closed today, and divides physicists in opposite clans. Some of them consider length contraction as a naive opinion, for example Wesley, Phipps, Cornille, Galeczki. Some others consider it as a fundamental process which explains a lot of experimental facts. Among them Bell, Selleri, Builder, et al. Length contraction had been proposed by Lorentz and Fitzgerald in order to explain the null result of Michelson's experiment. (In fact, the result was not completely null, but much weaker than expected). Length contraction was never observed. Of course, it cannot be observed directly by an observer in a moving frame, since the standard used to measure it, also contracts. But it could be observed indirectly. This was the objective of different renowned physicists who tried to observe the physical modifications entailed by motion: [e.g.,] variation of the refractive index of a refringent solid (Rayleigh and Brace); influence of the ether wind on a charged condenser (Trouton and Noble); the experiments of Trouton and Rankine and of Chase and Tomashek on the electrical resistance of moving objects; and finally of Wood, Tomlison and Essen on the frequency of the longitudinal vibration of a rod. But the experiments proved all negative" ("How the Apparent Speed of Light Invariance Follows from Lorentz Contraction," Joseph Lévy, France, unpublished, pp. 1-2. Lévy has also written: "Hidden Variables in Lorentz Transformation" (P. I. R. T., 1998) and "Some Important Questions Regarding Lorentz-Poincare's Theory and Einstein's Relativity" (P. I. R. T., 1996)).

A “world spirit,” who would permeate the whole system under consideration without being tied to a particular place or “in whom” the system would consist, and for whom it would be possible to “feel” all events directly would obviously immediately single out one of the frames of reference over all others.⁵⁵⁰

Obviously, Lorentz is finding it difficult to live in the universe he created for himself. Here he is searching for a ubiquitous entity that can not only sense and coordinate all events instantaneously, but one that can also provide him with an absolute frame of reference. Why? Because Lorentz knows deep within himself that it can work no other way. A world of relativity ends up in chaos. Without admitting it, Lorentz is asking for precisely what *Galileo Was Wrong* is providing – God and a fixed Earth.

For the time being, however, his “transformation” equation would spare him any tinge of guilt. This will not be the first time that mere imagination and mathematics comes to the rescue to solve scientific enigmas. As Alfred O’Rahilly opined: “The mathematicians got their chance and the semi-educated developed their natural gullibility.”⁵⁵¹ In the same vein, Engelbert Schücking boasted: “We have been able to scare most of the ministers out of cosmology by a straightforward application of tensor analysis.”⁵⁵² Critical of his colleagues, however, was [J. J. Thomson](#):

We have Einstein’s space, de Sitter’s space, expanding universes, contracting universes, vibrating universes, mysterious universes. In fact the pure mathematician may create universes just by writing down an equation, and indeed if he is an individualist he can have a universe of his own.⁵⁵³

⁵⁵⁰ Henrick Lorentz to Albert Einstein, January 1915, Robert Schulmann, A. J. Kox, Michael Janssen and József Illy, editors, *The Collected Papers of Albert Einstein, Correspondence 1914-1918*. Princeton: Princeton University Press, 1998, Document 43.

⁵⁵¹ Alfred O’Rahilly, *Electromagnetics: A Discussion of Fundamentals*, Longmans, 1938; Dover Reprint edition, 1965. p. 851.

⁵⁵² E. L. Schücking, “Cosmology,” *Relativity Theory and Astrophysics 1. Relativity and Cosmology*, ed. Jurgen Ehlers, Providence, RI: American Mathematical Society, 1967, p. 218, cited in *The Fingerprint of God*, p. 35. Tensor analysis, originally known as “absolute differential calculus,” was invented by Gregorio Ricci Curbastro and Tullio Levi-Civita. It was so abstruse that Alfred North Whitehead said of it: “It is not going too far to say that the announcement that physicists would have in the future to study the theory of tensors created a veritable panic among them when the verification of Einstein’s predictions was first announced” (Whitehead, *The Concept of Nature*, p. 182). This would not be the first, or last time, a scientific fraud was perpetrated by basing it merely on a mathematical “proof” too difficult for anyone to understand.

⁵⁵³ *Einstein: Life and Times*, p. 301.

Thomson's contemporary, Joseph Needham, said of the state of physics at the turn of the century:

The mathematisation of physics...is continually growing and physics is becoming more and more dependent upon the fate of mathematics....This special mathematics has for the greater part been created by the physicists themselves, for ordinary mathematics is unable to satisfy the requirements of present day physics.⁵⁵⁴

Stanislaw Ulam in *Adventures of a Mathematician*, adds:

I should add here for the benefit of the reader who is not a professional physicist that the last thirty years or so have been a period of kaleidoscopically changing explanations of the increasingly strange world of elementary particles and of fields of force. A number of extremely talented theorists vie with each other in learned and clever attempts to explain and order the constant flow of experimental results which, or so it seems to me, almost perversely cast doubts about the just completed theoretical formulations.⁵⁵⁵

Philosopher [Bertrand Russell](#) is a bit more sardonic:

Pure mathematics consists entirely of assertions to the effect that if such and such a proposition is true of *anything* then such and such another proposition is true of that thing. It is essential not to discuss whether the first proposition is really true, and not to mention what the anything is, of which it is supposed to be true. Both of these points would belong to applied mathematics....Thus mathematics may be defined as the subject in which we never know what we are talking about, nor what we are saying is true.⁵⁵⁶

Mario Livio, head of the science division of the Hubble Space Telescope, writes:

⁵⁵⁴ *Science at the Crossroads*, "Marx's Theory on the Historical Process," London, Frank Cass and Co., 1971, p. 189.

⁵⁵⁵ Stanislaw Ulam, *Adventures of a Mathematician*, 1976, p. 261.

⁵⁵⁶ Bertrand Russell, *Mysticism and Logic*, Doubleday, 1957, pp. 70-71, emphasis in the original. Russell was famous for causing the retraction of G. Frege's two-volume mathematical treatise by pointing out that the then current set theory, formulated by Georg Cantor, led to the absurd conclusion that: "N is a member of N set if, and only if, it is not a member of N set."

The success of pure mathematics turned into applied mathematics, in this picture, merely reflects an overproduction of concepts, from which physics has selected the most adequate for its needs – a true survival of the fittest. After all, “inventionists” would point out, Godfrey H. Hardy was always proud of having “never done anything ‘useful.’” This opinion of mathematics is apparently espoused also by Marilyn vos Savant, the “world record holder” in IQ – an incredible 228. She is quoted as having said “I’m beginning to think simply that mathematics can be invented to describe anything, and matter is no exception.”⁵⁵⁷

Even more critical of mathematics and its applications to science is Morris Kline, professor of mathematics at the Courant Institute and New York University. He writes:

The current predicament of mathematics is that there is not one but many mathematics and that for numerous reasons each fails to satisfy the members of the opposing schools. It is now apparent that the concept of a universally accepted, infallible body of reasoning – the majestic mathematics of 1800 and the pride of man – is a grand illusion. Uncertainty and doubt concerning the future of mathematics have replaced the certainties and complacency of the past. The disagreements about the foundations of the “most certain” science are both surprising and, to put it mildly, disconcerting. The present state of mathematics is a mockery of the hitherto deep-rooted and widely reputed truth and logical perfection of mathematics.

The disagreements concerning what correct mathematics is and the variety of differing foundations affect seriously not only mathematics proper but most vitally physical science...The loss of truth, the constantly increasing complexity of mathematics and science, and the uncertainty about which approach to mathematics is secure have caused most mathematicians to abandon science...The hope of finding objective, infallible laws and standards has faded. The Age of Reason is gone.⁵⁵⁸

⁵⁵⁷ Mario Livio, *The Golden Ratio*, New York, Random House, 2002, p. 245. The reference to “inventionists” refers to the debate whether mathematics has been invented or discovered.

⁵⁵⁸ Morris Kline, *Mathematics: The Loss of Certainty*, Oxford University Press, 1980, p. 6. Quoting Einstein he adds: “The relationship of mathematics to the physical world was well expressed by Einstein in 1921: ‘Insofar as the propositions of mathematics give an account of reality they are not certain; and insofar as they are certain they do not describe reality...’. Mathematicians had given up God and so it behooved them to accept man. And this is what they did. They continued to develop mathematics and to search for laws of nature, knowing that what they produced was not the design of God but the work of man” (*ibid.*, p. 97). The problems of mathematics are quite numerous,

Commenting on [Kurt Gödel's Incompleteness Theorem](#), another author offered a sobering assessment of what we can expect in the future:

...human beings can never formulate a correct and complete description of the set of natural numbers. But if mathematicians cannot even fully understand something as simple as number theory, then it is certainly too much to expect that science will ever expose any ultimate secret of the universe. Any system of knowledge about the world is, and must remain fundamentally incomplete, eternally subject to revision.⁵⁵⁹

For now the world would be satisfied that science had sufficiently answered the Earth-shattering dilemma brought to them by Michelson and Morley. Lost in the shuffle, however, was the simplest solution – the

yet most people are still under the illusion that mathematics is the perfect and unassailable science. Problems with infinite sets, the square roots of negative numbers, quaternions, Zeno's Paradox, Euclid's parallel postulate, and many more are well known. Just a couple of examples may suffice: (a) Karl Popper gives the example of:

“...the square root of 2...consists in showing that the assumption (1) $\sqrt{2} = n/m$, that is that $\sqrt{2}$ is equal to a ratio of any two natural numbers, n and m , leads to an absurdity. We first note that we can assume that (2) not more than one of the two numbers, n and m , is even. For if both were even, then we could always cancel out the factor 2 so as to obtain two other natural numbers, n' and m' such that $n/m = n'/m'$ and such that at most one of the two numbers, n' and m' would be even. Now by squaring (1) we get (3) $2 = n^2/m^2$, and from this (4) $2m^2 = n^2$, and thus (5) n is even. Thus there must exist a natural number a so that (6) $n = 2a$, and we get from (3) and (6) [the next step] (7) $2m^2 = n^2 = 4a^2$, and thus (8) $m^2 = 2a^2$. But this means (9) m is even. It is clear that (5) and (9) contradict (2). Thus the assumption that there are two natural numbers, n and m , whose ratio equals $\sqrt{2}$, leads to an absurd conclusion. Therefore $\sqrt{2}$ is not a ratio, it is ‘irrational’” (*Conjectures and Refutations: The Growth of Scientific Knowledge*, p. 86; Mario Livio, *The Golden Ratio: The Story of Phi, The World's Most Astonishing Number*, New York, Random House, 2002, pp. 36-39).

See also: Morris Kline, *Mathematics and the Search for Knowledge*, Oxford University Press, 1986; *Mathematics and the Physical World*, Dover Publications, 1981; Eugene P. Northrop, *Riddles in Mathematics*, Krieger Publishing, 1975; *Mathematics and Western Culture*, Oxford University Press, 1953; Evert Beth, *The Foundations of Mathematics*, New York, Harper and Row, 1966; W. Rudin, *Mathematical Analysis*, New York, McGraw-Hill, 1964; J. M. Dubbey, *Development of Mathematics*, Crane, Russak and Co., 1970; W. S. Hatcher, *Foundation of Mathematics*, W. B. Saunders, 1968; A. Robinson, “The Metaphysics of the Calculus” in *The Philosophy of Mathematics*, ed. J. Hintikka, Oxford University Press; E. Gilson, *The Philosophy of St. Bonaventure*, New Jersey, St. Anthony Guild Press, 1965; Eugene Wigner, “The Unreasonable Effectiveness of Mathematics in the Natural Sciences,” *Communications on Pure and Applied Mathematics XIII* (1960); Leonard M. Wapner, *The Pea and the Sun*, A. K. Peters Co., 2005, detailing the 1924 Tarski paradox and the 1014 Hausdorff paradox.

⁵⁵⁹ Rudy Rucker, *Infinity and the Mind*, Boston, Birkhauser, 1982, p. 165.

one that didn't involve inventing mathematical fudge factors. But of course, that solution was "unthinkable." Science just "knew" that the Earth moved. Unfortunately, Lorentz and Fitzgerald never explained why, if the apparatus of Michelson-Morley's experiment shrunk when it moved against the ether, that the Earth itself, and everything on its surface, did not also contract, including the eye-piece of Michelson's interferometer and the cornea of his retina. If it all contracts, as the theory should be forced to admit, then all contractions would cancel each other, leaving Lorentz and Fitzgerald without a solution to the problem.

But now that science fooled itself into thinking that the null result had been solved, there were still other issues that needed to be addressed. If everything is in motion and there is no center point in space, then how can we be sure of things we measure? What standard ruler, what immovable object, could be used to measure one thing against another? While Lorentz and Fitzgerald were tackling the mechanics of light beams and moving objects, [Henri Poincaré](#) was postulating about the new "relative" universe. In 1896 Poincaré gave a speech at the International Congress of Mathematicians in Zurich describing his own non-Euclidean relativity theory. Einstein was a student there at the time. Poincaré's penchant toward making everything relative is precisely what we would expect once it is postulated that measuring rods contract when they are moving at speeds as slow as 30 km/sec. The whole universe is now outside of the realm of certainty, since no one can ever say for certain what is big or small or fast or slow. In 1904, Poincaré gave another speech on the same subject, this time to the Congress of Arts and Sciences, but a speech that, in his own words, was "an indication of the scientific unrest and philosophical distrust created not only by the Michelson-Morley experiment, but by others made during the preceding two decades..."⁵⁶⁰

⁵⁶⁰ *Einstein: The Life and Times*, p. 113. After hearing the news that Walter Kaufmann's 1905-1906 experiment disproved both Lorentz and Einstein, Lorentz, not being able to add any more modifications to his view, wrote to Poincaré: "Unfortunately my hypothesis of the flattening of electrons is in contradiction with Kaufmann's results, and I must abandon it. I am, therefore, at the end of my Latin." Poincaré stated: "The principle of relativity thus does not appear to have the rigorous validity which one was tempted to attribute to it" (*Thematic Origins of Scientific Thought*, Gerald Holton, Harvard University Press, 1988, p. 206). In a 1907 article, Einstein acknowledged that his theory conflicted with Kaufmann's results, and admitted, at least at that time, he could find no errors in Kaufmann's experiment or interpretation. But Einstein would not give up, since his theory, based on a macro-evaluation of the whole universe, did not consider micro-results to undermine the basic postulates of his theory. Someway would be found to vindicate Einstein, as has always been the case with physics since 1905. Kaufmann's experiment involved the deflection of electrons in an electromagnetic field. Kaufmann writes in a Nov. 30, 1905 note: "In addition there is to be mentioned a recent publication of Mr. A. Einstein on the theory of electrodynamics which leads to results which are formally identical with those of Lorentz's theory. I anticipate right away the general result of the [Kaufmann] measurements to be described in the following: the results are not compatible with the Lorentz-Einstein fundamental assumptions." The reason is that Kaufmann's attenuation

Perhaps Poincaré was referring to the results of Arago and Airy, which up to this time had not been answered by the scientific establishment. A motionless Earth, of course, would have solved all the problems confronting scientists and philosophers, for it would provide a firm and unmovable standard by which to measure anything in the known universe. The scientific unrest was just beginning, however. The implications of the Lorentz-Fitzgerald contraction would press deep into the heart of physics and question its very foundations. It was one thing to say that rods shrank as they moved through the ether with the Earth, but to be consistent Lorentz realized that clocks running through the ether must also be affected and thus tick more slowly by the same factor that made the rods shrink. They had no choice but to alter time, for if someone with a normal-running clock is keeping the time of how long it takes the light beam to travel through the ether in Michelson-Morley's experiment, he will record that the beam reached its destination later than it should have, that is, it would have reached its destination later than the beam traveling perpendicular to the Earth's motion and thus cause fringe shifts to appear. So in order to have the clock accommodate an experiment in which no fringe shifts appear, not only must lengths shorten, but the clock calculating how long it took the light beam to travel the shortened distance must run slower than normal. The Relativist is forced to this position. If not, then the light beam will arrive sooner than it should. So now we have what modern science calls "time dilation." The pace of time itself can change, and therefore it is as relative as everything else.

The problems are not over yet. Not only would time be forced to slow down, but Poincaré showed through the laws of momentum that the

factor of the electric field strength that deflected the electrons (his "k" value) implied a velocity greater than the speed of light. Max Planck then readjusted Kaufmann's "k" value to give a slight favoring toward the Lorentz-Einstein theory. In 1908, Bucherer performed a variation of Kaufmann's experiment using Planck's recalculated "k" values, which allowed it to agree more with the Lorentz-Einstein model. Planck's partiality toward Einstein's Special Relativity theory was no secret, however. As Brush reports: "Planck presented the theory at the physics colloquium in Berlin during the winter semester 1905-6 and published a paper on it in 1906 (the first publication on relativity other than Einstein's)...As editor of the prestigious journal *Annalen der Physik*, Planck saw to it that any paper on relativity meeting the normal standards would get published. According to Goldberg, Planck was attracted to relativity theory because of 'his philosophical and ethical convictions about the ultimate laws of reality'" (Stephen Brush, "Why Was Relativity Accepted?" p. 193). In any case, Brush recognizes that Planck's readjustment of the "k" value only showed that "Kaufmann's data did not rule out relativity," not that it vindicated Relativity. Gerald Holton takes a more negative view of Bucherer's results, stating: "theories of electron motion given earlier by Abraham and by Bucherer do give predictions considerably closer to the experimental results of Kaufmann. But Einstein refuses to let the 'facts' decide the matter." Holton says that "the work of Guye and Lavanchy in 1916" found errors in Kaufmann's equipment, which was "an inadequate vacuum system" discovered by Lorentz (*Thematic Origins of Scientific Thought*, pp. 206, 231, 253).

mass of an object moving against the ether had to increase. Thus, length, time and mass must change to accommodate the null results of Michelson-Morley. Since they were all interconnected they had to stay in balance, otherwise the mathematics would not work. Confounded by all these requirements, Lorentz and Poincaré complained: “nature was conspiring against us.” Needless to say nature wasn’t conspiring against them; they were conspiring against themselves. Nature was shouting loud and clear that these absurd contortions of length, time and mass could all be avoided if one would simply start from the fact that the Earth was standing still in space. Absolute time, length and mass would be a natural result of a stationary Earth. But scientists were simply not listening to nature. The stakes were too high for them to hear her sweet, soft voice. This was a battle for who was going to control the world and the minds of its people: would it be the Church and the Bible or atheistic science? With Lorentz creating his mathematical fudge factor to explain the Michelson-Morley experiment, and Poincaré developing the first phases of the theory of Relativity, the stage was now being set for Albert Einstein to put what science hoped would be the final nail into the coffin of a motionless Earth.

Albert Einstein Enters the Fray

How much did the Michelson-Morley experiment influence the thinking of Albert Einstein? Most biographers, historians and academics say that it affected him tremendously, although there are a few who say it was only indirectly.⁵⁶¹ The issue is somewhat difficult because Einstein himself gave different testimonies. We have already noted that Einstein showed particular concern for, as he put it, “the Fizeau experiment on the effect of moving water on the speed of light, and by astronomical aberration, especially Airy’s observations with a water-filled telescope,” but since Michelson-Morley was principally connected to these previous experiments then it should have had an affect on Einstein. Moreover, if it was not precisely the Michelson-Morley experiment that was the primary motivating factor for Einstein in the formulation of his Relativity theory, it was certainly the whole cadre of similar experiments performed after 1887 and prior to 1905, namely, those of Roentgen, Lodge, Rayleigh, Brace, Trouton-Noble and Morley-Miller, all of which produced the same results as Michelson-Morley. Einstein admitted as much in his famous 1905 paper as he makes explicit reference to “the unsuccessful attempts to discover any motion of the Earth relative to the light medium.”⁵⁶² We can be sure of one fact: all of the aforementioned experiments from Roentgen to Miller concerned one thing, and one thing only – “motion of the Earth relative to the light medium.”

More specific information that Einstein based Relativity primarily on the Michelson-Morley experiment comes from various sources. Robert Shankland, who worked with Einstein in the 1950s, reveals some persuasive information. When he visited Einstein in 1950, he asked him how he learned of the Michelson-Morley experiment. In this instance Einstein replied that he had “become aware of it through the

⁵⁶¹ Among the more notables are, Stephen Hawking in the best-selling *A Brief History of Time*, p. 20, and Richard Feynman in “The Feynman Lectures on Physics,” Vol. 1, Reading, Massachusetts: Addison-Wesley, 1963, p. 15, cited in Holton, p. 350. I would estimate that over 95% of the literature holds that Einstein based his theory of Relativity directly upon the Michelson-Morley experiment. Holton sees this as “folklore,” and claims that Michelson-Morley had only an “indirect” effect on Einstein’s thinking. He cites one or two others in support of his thesis. In the end, Holton’s special pleading makes little difference since, as noted above, Einstein made explicit reference to all the “unsuccessful attempts to discover any motion of the Earth,” which, after the fact, would include Michelson-Morley.

⁵⁶² “Zur Elektrodynamik bewegter Körper,” *Annalen der Physik*, 4th series, 17, Sept. 26, 1905. The full paragraph is: “Examples of this sort, together with the unsuccessful attempts to discover any motion of the Earth relative to the ‘light medium,’ suggests that the phenomena of electrodynamics as well as of mechanics possess no properties corresponding to the idea of absolute rest. They suggest rather that, as has already been shown to the first order of small quantities, the same laws of electrodynamics and optics will be valid for all frames of reference for which the equations of mechanics hold good.”

writings of H. A. Lorentz, but *only after 1905*.” Two years later (1952), Shankland again asked Einstein the same question, wherein Einstein stated: “This is not so easy. I am not sure when I first heard of the Michelson experiment.” Shankland goes on to comment:

However, Einstein said that in the years 1905-1909, he thought a great deal about Michelson’s result in his discussions with Lorentz and others in his thinking about general relativity. He then realized (so he told me) that he had also been conscious of Michelson’s result *before 1905* partly through his reading of the papers of Lorentz and more because he had assumed this result of Michelson to be true.⁵⁶³

This is confirmed by a letter that Einstein wrote to Marcel Grossmann in 1901, in which he stated:

A new and considerably simpler method for the investigation of the motion of matter with respect to the luminiferous ether has come into my mind. It is based on the usual interference experiments. If only once inexorable destiny will allow me to

⁵⁶³ *Einstein: The Life and Times*, pp. 128-129. Emphasis added. A longer quote appears in *Thematic Origins of Scientific Thought*, pp. 300-301. Holton admits: “We have positive evidence of Einstein having read only one paper and one book by Lorentz – the paper of 1892 and the book of 1895.” Of the 1895 book, Holton attempts to downplay the facts, stating: “...the Michelson ether-drift experiments are only briefly mentioned (on p. 2)...The matter is not brought up again until page 120.” Also, Holton admits to “a newly found letter of 1899 (Document 57 of “The Collected Papers of Albert Einstein,” vol. 1 [Princeton: Princeton University Press, 1987]) in which Einstein indicated that he had read Wilhelm Wien’s paper, “Ueber die Fragen, welche die translatorische Bewegung des Lichtäthers betreffen,” *Annalen der Physik und Chemie*, 65:1-xvii, 1898. In it Einstein would have seen a discussion of ten ‘experiments with negative result’ on the supposed existence of a fixed ether; the Michelson-Morley experiment was the last on Wien’s list, with Wien’s acknowledgement that it was necessary to adopt a ‘hypothesis’ of the compensatory shrinking of the length dimensions of rigid bodies to rescue the interpretation of the experiment” (*The Thematic Origins of Scientific Thought*, p. 478). Also G. H. Keswani was able to show that Einstein had, previous to his “Electrodynamik” paper of 1905, read *Science et Hypothèse*, written by Henri Poincaré. The index of Poincaré’s book mentions Michelson four times in connection with the Michelson-Morley experiment (G. H. Keswani in “The Origin and Concept of Relativity,” *British Journal for the Philosophy of Science* 15: 286-306, 1965. This evidence shows that Einstein not only knew of the Michelson-Morley experiment before his 1905 paper, but also its implications. Thus, statements of Einstein’s, such as the one in the letter to a “Mr. Davenport” that Holton cites Einstein writing, which says, “In my own development Michelson’s result has not had a considerable influence. I do not even remember if I knew of it at all when I wrote my first paper on the subject (1905)...One can therefore understand why in my personal struggle Michelson’s experiment played no role or at least no decisive role,” seem to be both a convenient a lapse of memory and an equivocation.

finish with the necessary time and calm! When we meet again,
I will tell you all about that.⁵⁶⁴

The “usual interference experiments” not only point to the Michelson-Morley experiment but to the many repeats of that experiment performed by various scientists (Lodge, Brace, *et al*) up until 1901. Einstein’s knowledge of them is supported by an account that Albert Michelson’s biographer, Bernard Jaffe, records from Einstein’s speech in honor of Michelson:

I have come among men who for many years have been true comrades with me in my labors. You, my honored Dr. Michelson, began with this work when I was only a little youngster, hardly three feet high. It was you who led the physicists into new paths, and through your marvelous experimental work paved the way for the development of the Theory of Relativity. You uncovered an insidious defect in the ether theory of light, as it then existed, and stimulated the ideas of H. A. Lorentz and Fitzgerald, out of which the Special Theory of Relativity developed. Without your work this theory would today be scarcely more than an interesting speculation; it was your verifications which first set the theory on a real basis.⁵⁶⁵

Hence, with this evidence in the background, it is safe to say that Einstein’s theory of Relativity was based and formulated, at least in large

⁵⁶⁴ Albert Einstein, “Letter to Grossman, 6/9/1901,” EA, 11-485, cited in Ludwik Kostro, *Einstein and the Ether*, Apeiron, 2000, p. 16.

⁵⁶⁵ Bernard Jaffe, *Michelson and the Speed of Light*, New York, Doubleday, 1960, pp. 167-168. Holton points out that there is a sentence in the original German after the clause “out of which the special theory of relativity developed,” which is “These in turn led the way to the general theory of relativity, and to the theory of gravitation.” From this addition Holton claims that this “switches the discussion away from Michelson and special relativity toward the assembled astronomers and general relativity” (*Thematic Origins of Scientific Thought*, p. 338). But our interest is not so much General Relativity, but what Einstein knew about Michelson’s experiment and its implications before he wrote his 1905 paper on Special Relativity. In any case, Holton is forced to admit Einstein’s statement on July 17, 1931 to the Physikalische Gesellschaft of Berlin in memory of Michelson (who died two months earlier) that Michelson’s greatest idea, as Einstein put it “was the invention of his famous interference apparatus, which came to be of greater significance both for relativity theory as well as for the observation of spectral lines...this negative result [of the Michelson experiment] greatly advanced the belief in the validity of the general relativity theory” (*ibid.*, p. 339). Holton also wrote “On the Origins of the Special Theory of Relativity,” in *American Journal of Physics*, Vol. 28 (1960), of which the relevant detail is on pages 627-636. On his side is Stephen Brush, who states that Michelson-Morley “was not the primary motivation for his research, and had only a small and indirect effect on his early work” (“Why Was Relativity Accepted?” *Physics in Perspective* 1 (1999), p. 187). This is, indeed, a dubious conclusion when everyone else (Fitzgerald, Lorentz, Poincaré, *et al*) saw Michelson-Morley as quite a dilemma for physics.

part, upon the results of the Michelson-Morley experiment. In fact, it could be said that Einstein was at the mercy of the Michelson-Morley experiment. Even though Albert Michelson and Edward Morley promised in their original 1887 paper that “the experiment would be repeated at intervals of three months, and thus all uncertainty will be avoided,”⁵⁶⁶ they never produced another set of readings. The whole world was dependent on only 36 readings taken over six hours in four days, a pittance by scientific standards.⁵⁶⁷

In the meantime, [Wilhelm C. Roentgen](#), famous for the discovery of X-rays, performed an experiment in 1888 (which was the forerunner of the Trouton-Noble experiment of 1903) and reported his “unsuccessful” attempt in detecting the “velocity of the Earth through the ether.”⁵⁶⁸ [Sir Oliver Lodge](#), who received fame for his work in electricity, performed “ether wave” experiments in 1892, which were designed to detect the Earth’s motion through space. He sent light beams

⁵⁶⁶ “On the Relative Motion of the Earth and the Luminiferous Ether,” *American Journal of Science*, Third Series, Vol. xxxiv (203), Nov. 1887.

⁵⁶⁷ Michelson and Morley took 17 readings twice each day (noon and evening) on July 8 and 9, and one reading each on July 11 and 12:

- Trial 1: July 8 (noon): -0.001; +0.024; +0.053; +0.015; -0.036; -0.007; +0.024; +0.026; -0.021; -0.022; -0.031; -0.005; -0.024; -0.017; -0.002; +0.022; -0.001.
- Trial 2: July 8 (evening): -0.016; +0.008; -0.010; +0.070; +0.041; +0.055; +0.057; +0.029; -0.005; +0.023; +0.005; -0.030; -0.034; -0.052; -0.084; -0.062; -0.016.
- Trial 3: July 9 (noon): +0.018; -0.004; -0.004; -0.003; -0.031; -0.020; -0.025; -0.021; -0.049; -0.032; +0.001; +0.012; +0.041; +0.042; +0.070; -0.005; +0.018.
- Trial 4: July 9 (evening): +0.007; -0.015; +0.006; +0.004; +0.027; +0.015; -0.022; -0.036; -0.033; +0.001; -0.008; -0.014; -0.007; +0.015; +0.026; +0.024; +0.007.
- Trial 5: July 11 (noon): +0.015; -0.035; -0.039; -0.067; -0.043; -0.015; -0.001; +0.027; +0.001; -0.011; -0.005; +0.011; +0.047; +0.053; +0.037; +0.005; +0.015.
- Trial 6: July 12 (evening): +0.034; +0.042; +0.045; +0.025; -0.004; -0.014; +0.005; -0.013; -0.030; -0.066; -0.093; -0.059; -0.040; +0.038; +0.057; +0.041; +0.034;

⁵⁶⁸ W. C. Roentgen (or Röntgen), *Annalen der Physik* 35:264, 1888. After Roentgen, A. Eichenwald, *Annalen der Physik* 11:1, 241, 1903, and H. A. Wilson, *Philosophical Transactions of the Royal Society*, London 204:121, 1904, used the “Roentgen convection” with electric and magnetic fields, respectively, but with no significant results.

between rapidly moving steel disks to test the hypothesis that, as matter moved, it would drag ether with it. He observed no such effect.⁵⁶⁹ If there was no ether drag, an obvious conclusion would be that the Earth was not moving through the ether, and thus standing still in space, but neither Lodge nor his colleagues were of the frame of mind to consider such an option.⁵⁷⁰ Still, Lodge showed, contrary to Michelson's 1887 experiment, that light was not affected by the motion of adjacent matter. This led Michelson to plan a repeat of his 1887 experiment in 1897, since he proposed to himself that perhaps in his first attempt in the basement laboratory in Cleveland the ether was "trapped" and therefore became motionless. But in 1897 Michelson found that there was no difference when the interferometer was placed above the ground. The displacement was less than one-twentieth of a fringe.⁵⁷¹

In 1902, [Lord Rayleigh](#) performed another ether-drift experiment, this one depending on a refractometer that would produce a double refraction of light. His concept was to discharge polarized light in a direction parallel to the motion of ether-drift (or the motion of the Earth) over against polarized light perpendicular to that direction, thus causing a different velocity in the two beams, which would be detected by a double refraction. Rayleigh was unable to detect any effect, although some claim that his equipment may not have been sensitive enough to give a positive result.⁵⁷² To rectify this apparent problem, in 1904 [DeWitt Bristol Brace](#) built an apparatus that had 150 times more sensitivity than Rayleigh's. Brace reflected the light back and forth several times and thus was able to increase the light path to 30 meters. In

⁵⁶⁹ *Philosophical Transcripts of the Royal Society*, London 184: 727-804, 1893; 189:149-166, 1897. In his book *The Ether of Space* he writes: "At first I saw plenty of shift...On stopping the disks the bands returned to their old position. On starting them again in the opposite direction the bands ought to have shifted the other way too, if the effect were genuine; but they did not; they went the same way as before. The shift was therefore wholly spurious...We have no means of getting hold of the ether mechanically; we cannot grip it or move it in the ordinary way: we can only get it electrically. We are straining the ether when we charge a body with electricity; it tries to recover, it has the power of recoil." In another work he writes: "...space empty of matter is endowed with finite and measurable physical properties. It is absolutely transparent and undispersive. In other words it quenches no light but transmits it undiminished in total intensity, though diluted by spreading..." (Oliver Lodge, *The Ether of Space*, New York, Harper, 1909. p. 70).

⁵⁷⁰ In Lodge's book, *The Ether of Space*, he consistently refers to "Earth's moving through space at nineteen miles a second" as the basis for all his interpretations of the interferometer experiments (pp. 48, 55, 58, 61, 63, 66, 68), never once allowing for an immobile Earth to answer the perplexing questions.

⁵⁷¹ Dorothy Michelson Livingston, *The Master of Light: A Biography of Albert A. Michelson*, p. 200.

⁵⁷² *Philosophical Magazine*, 4, 678, 1902 and 1904. Also, "On the Theory of Optical Images," *Philosophical Magazine*, 42:167, 1896.

order to detect the rotation of the direction of polarization, he invented a very sensitive polarimeter for the occasion. With this equipment he could detect a difference of up to 7.8×10^{-13} between the two velocities, which was 300 times greater than the Michelson-Morley experiment.⁵⁷³ Brace reported that he did not find any ether drift. Lorentz, assuming again that the Earth was in motion, described their efforts as follows:

Rayleigh and Brace have examined the question whether the Earth's motion may cause a body to become doubly refracting. At first sight this might be expected, if the just mentioned chance of dimensions is admitted. Both physicists, however, have obtained a negative result.⁵⁷⁴

Just a year prior (1903) F. T. Trouton and H. R. Noble did another experiment to detect ether drift. Their results seemed to confirm the thesis that there was no significant drift, although the interpretation of that experiment is still in dispute.⁵⁷⁵ Using even more sophisticated

⁵⁷³ "Double Refraction in Matter Moving Through the Ether." *Philosophical Magazine*, new series, 7: 317-328, 1904. Interestingly enough, Brace also tested the Lorentz-Fitzgerald contraction hypothesis, using optical methods, and found it unsupported by his results.

⁵⁷⁴ "Electromagnetic Phenomena in a System Moving with any Velocity Less Than that of Light," H. A. Lorentz, cited in *The Principle of Relativity*, Dover Publications, 1952, p. 11.

⁵⁷⁵ At the suggestion of Fitzgerald, Trouton and Noble suspended a highly-charged parallel-plate capacitor. If the Earth is moving through the ether, an electromagnetic torque is expected due to magnetic forces, since the capacitor is moving through the ether. The plate will minimize its total energy and seek a stable position parallel to the direction of the motion of the Earth (e.g., a zero-point field). Trouton and Noble reported a null result, that is, the plate did not orient itself in a position which eliminates the angular momentum against the velocity of the Earth (F. T. Trouton and H. R. Noble, "The forces acting on a charged condenser moving through space," *Proceedings of the Royal Society*, Vol. 72, p. 132, 1903; *Phil. Trans. Royal Soc. A* 202, 165-181, 1903. In 1927, Carl T. Chase confirmed Trouton-Noble's results (C. T. Chase, "A repetition of the Trouton-Noble ether drift experiment," *Physical Review*, Vol. 28, p. 378, 1926; 30, 516-519, 1927). As recently as 1994, H. C. Hayden reconfirmed the null result with an apparatus 105 times more sensitive than Trouton-Noble's (H. C. Hayden, "High sensitivity Trouton-Noble experiment," *Review Scientific Instruments*, Vol. 65, No. 4, p. 788, 1994), but Hayden stated that one could not argue for the existence of ether (H. C. Hayden, "Analysis of Trouton-Noble experiment, Galilean Electrodynamics," Vol. 5, No. 4, p. 83, 1994). His claim has been contested in 1998 by Patrick Cornille and Jean-Louis Naudin (P. Cornille, "Correspondence: Making a Trouton-Noble experiment succeed," *Galilean Electrodynamics* 9 (2), 33, 1998. P. Cornille, "A linear Trouton-Noble experiment which shows the violation of Newton's third law," *Hadronic J. Supplement* 13 (2), 191-202, 1998, and in 2000 by Alexandre D. Szames, Patrick Cornille, Jean-Louis Naudin and Christian Bizouard). The latter's abstract states: "When correctly performed, this very simple electrostatic ether drift experiment gives unambiguous positive results: a suspended, parallel-plate capacitor charged at high voltage by means of lateral feeding wires exhibits a stimulated torque and tends to line up its plates in the East-West direction" (AIP Conference Proceedings Vol. 504 (1) pp.

interferometers, most scientists found “null” results similar to those of Michelson-Morley. Experiments by Trouton and Rankine⁵⁷⁶ and of Chase and Tomashek⁵⁷⁷ on the electrical resistance of moving objects, and also of Wood, Tomlinson and Essen⁵⁷⁸ on the frequency of the longitudinal vibration of a rod likewise proved “negative.” In 1903-1905 [Edward Morley](#) and [Dayton Miller](#) tested for ether drag in a series of interferometer experiments and found the same results as Morley’s 1887 experiment, at least no results above 8 km/second for the respective speed of ether against Earth.⁵⁷⁹ As we will see later, when Miller worked by himself in 1925, he again found an ether drift of 8-10 km/sec.

With all these “negative” experimental results, in addition to those of Michelson-Morley in 1881 and 1887, the evidence was mounting like flood water at the dam. If someone did not find an answer soon, the dam was going to break. On the macro-level, there were only two possible answers: (a) either the Earth was motionless in space or (b) the Earth was carrying the ether with it as it revolved around the sun. But since having the Earth carry the ether led to difficulties with the observed aberration of starlight (as we saw with the Arago, Airy and Fresnel affair), this left only a motionless Earth to solve the problem, but that solution was “unthinkable” to modern man.

Because the attempts of Lorentz and Poincaré at answering Michelson-Morley, Lodge, Brace, Rayleigh and Trouton-Noble were

1004-1017, January 19, 2000). See also Saul A. Teukolsky, “The explanation of the Trouton-Noble experiment revisited,” *American Journal of Physics* 64 (9), 1104–1109, 1996; Oleg D. Jefimenko, “The Trouton-Noble paradox,” *Journal of Physics A*, 32, 3755–3762, 1999; L. Nieves, M. Rodriguez, G. Spavieri, and E. Tonni, “An experiment of the Trouton-Noble type as a test of the differential form of Faraday’s law,” *Il Nuovo Cimento* 116 B (5), 585–592 (2001). Michel Janssen, “A comparison between Lorentz’s ether theory and special relativity in the light of the experiments of Trouton and Noble,” Ph.D. thesis, 1995.

⁵⁷⁶ F. T. Trouton and A. D. Rankine, “On the Electrical Resistance of Moving Matter,” *Proceedings of the Royal Society* 80, 420, 1908.

⁵⁷⁷ C. T. Chase, *Physical Review*, 30, 516 (1927); R. Tomashek, *Annalen der Physik*, 73, 105, 1924; 78, 743, 1925; 80, 509, 1926; 84, 161, 1927.

⁵⁷⁸ A. B. Wood, G. A. Tomlinson, L. Essen, “The Effect of the Fitzgerald-Lorentz Contraction on the Frequency of Longitudinal Vibration of a Rod,” *Proceedings of the Royal Society*, 158, 6061, 1937.

⁵⁷⁹ Morley and Miller had extended the paths of the light beams considerably in contrast to the 1887 experiment, and also replaced the foundation of their apparatus with stone, wood and steel, respectively. In the third trial of 1905, they moved the apparatus to a hill in Cleveland Heights, Ohio, which was 285 meters high, but this did not change the results, which was an ether wind of about 3.5 kilometers per second. Morley and Miller also tested for Fitzgerald’s contraction hypothesis and found their results did not support it. Because of other pressing issues, Miller would not return to these experiments until 1921.

unsatisfactory to Einstein, he set out to create his own theory, and one that would put a significant demarcation between all past science and future science. As noted earlier, Einstein was well aware of the implications of these experiments, since he makes explicit mention in his 1905 paper of “the unsuccessful attempts to discover any motion of the Earth.” This certainly coincides with Einstein’s statement in 1921 that his theory of Relativity “is not speculative in origin; it owes its invention entirely to the desire to make physical theory fit observed fact as well as possible.”⁵⁸⁰ In fact, so pressured was Einstein to explain these experiments that, in his effort to save Copernicus, he would end up destroying the idea of a heliocentric system in exchange for an a-centric system, as well as obliterating Isaac Newton’s concept of “absolute space.” Up until Einstein, men had believed in some type of absolute space and absolute time. They didn’t know the precise constitution of space, but intuitively they reasoned that something real and substantive had to occupy the space between Earth and the stars. As Oliver Lodge had described it: “space empty of matter is endowed with finite and measurable physical properties. It is absolutely transparent and undispersive....a perfect continuum, an absolute plenum.”⁵⁸¹ This ‘substance’ would serve as the background against which to make all cosmic measurements, even if only theoretical.⁵⁸² Because Galileo and Newton rejected a centrally located and motionless Earth, they were in desperate need of a motionless medium outside of Earth to serve as the standard upon which all other objects of the universe moved and could be measured. Although Newton did not believe that absolute motion could be detected by mechanical means (since all objects were in motion), this left room for absolute motion to be detected by non-mechanical devices, namely light. But because Hoek’s, Airy’s, and Michelson-Morley’s experiments with light did not detect absolute motion through a medium (the medium commonly known as “ether”), then Einstein understood that he had two choices: either Earth was not in motion, or the ether did not exist and absolute motion could never be

⁵⁸⁰ *Einstein: The Life and Times*, p. 128.

⁵⁸¹ *The Ether of Space*, New York and London, Harper and Brothers, 1909, p. 95.

⁵⁸² We emphasize “theoretical” to accommodate the fact that since Newton’s heliocentrism did not leave him with any heavenly body at rest, he thus depended on his own “relativity” to understand motion. As Newton put it in his *Principia*: “It may be that there is no body really at rest, to which the places and motions of others may be referred.” As a result, Newton’s relativity then leads to his three laws of motion. As Rom Harré describes it: “We must notice a peculiarity of his [Newton’s] famous laws. They have an important mathematical property, called Galilean Invariance. This property means that Newton’s Laws of Motion are the same for all bodies, no matter how fast they are moving relative to each other....It follows that there is no mechanical way of detecting one’s absolute motion” (*Great Scientific Experiments*, Oxford, Phaidon Press Ltd., 1981, p. 126).

detected, even when using light. The difference between Newtonian Relativity and Einsteinian Relativity is that the former says absolute motion cannot be detected by mechanical means, while the latter says it cannot be detected either by mechanical or non-mechanical means. As noted above, a third choice not favorable to Einstein, and the one that would favor Newtonian Relativity, was that the ether moved with the Earth and at the same speed, commonly known as “ether entrainment.” Various modern ether theories opt for this choice since they reject Relativity theory, but still accept that a moving Earth is a sacrosanct fact of science. The major problem with the ether entrainment theory, however, is that it will necessarily require a demarcation between the entrained and non-entrained ether, or at least gradient levels of entrained ether, but these are distinctions which have no experimental evidence to support them. What we know is that the ether is there and it is consistent. As Herbert Ives acknowledged:

The frequent assertion that ‘the Michelson-Morley experiment abolished the ether’ is a piece of faulty logic. When Maxwell predicted a positive result from the experiment he did so on the basis of *two* assumptions; the first, that the light waves were transmitted through a medium, the second, which was not realized until pointed out by Fitzgerald, that the measuring instruments would not be affected by motion. The null result of the experiment proved *some* assumption made in predicting a positive result to be wrong. The experimental demonstration of the variation of measuring instruments with motion, in exactly the way to produce a null result, shows that it was the second assumption alone that was wrong; leaving evidence for a transmitting medium, as derived from aberrational and rotational phenomena [cf., Arago, Airy, *et al.*], as strong, if not stronger, than ever.⁵⁸³

Einstein, of course, opted to eliminate the ether and resign the world to having no absolutes. As he developed his theory to support that choice, he was hailed as the greatest scientist the world has ever known. Modern humanity was on the brink of utter humiliation before the Greeks, Romans, Egyptians and Babylonians, but Einstein, at least so the world thought, saved them from having to bow the knee. As we will see, Einstein created two theories to replace Newton. The Special Relativity theory held that there is no absolute time or absolute space; while the General Relativity theory held that space moved (or “curved”), and this movement is the principle cause of gravity, among other things.

After Poincaré initial work, Einstein further developed the mathematics behind the theory of Relativity. He realized that in order to

⁵⁸³ “The Measurement of the Velocity of Light by Signals Sent in One Direction,” *Journal of the Optical Society of America*, Oct. 1948, vol. 38, no. 10, p. 879.

maintain the mathematical validity of his theory (that is, that the light beams of the interferometer were equal in speed), contractions of time and length could not be ignored. But whereas Lorentz had invented the length contractions to compensate for the ether's effect on the light beam, Einstein dispensed with the ether altogether, and thus he was left only with having to explain the time contraction.⁵⁸⁴ Because he believed Earth's motion through space was a proven fact, Einstein eliminated the ether because, as he understood it, no experiment had demonstrated its existence. Like his predecessors, Einstein "knew" the Earth moved, so it was virtually inevitable that he, or someone else, would conclude that ether did not exist. We know, of course, that the evidence demonstrated only that Earth was not moving at 30+ km/sec through the ether, not that ether was non-existent. Eliminating the ether certainly solved a lot of problems, but like any *ad hoc* solution, it created additional ones.⁵⁸⁵

⁵⁸⁴ Interestingly enough, in Einstein's theory one might say there is no real length contraction (only apparent contraction) because, without ether, there is no measurable motion between the apparatus and the observer. Ives, quoting Lorentz about his own contraction formula, states: "[it] enables us to predict that no experiment made with a terrestrial source of light will ever show us the influence of the Earth's motion." Here Lorentz admits that, the very basis for his experiment (i.e., a moving Earth), cannot be proven by experiment. As for Einstein's mathematics, Ives goes on to say: "Einstein, starting with this conclusion [that no experiment will show the influence of the Earth's motion]...and elevating it to a new principle of physics, was able, by working backward, to deduce the contraction formula $(1 - v^2/c^2)^{1/2}$ " ("Historical Note on the Rate of a Moving Clock," *Journal of the Optical Society of America*, Oct. 1947, vol. 37, no. 10, p. 810).

⁵⁸⁵ The differences between the Lorentz's theory and Einstein's theory, as Herbert Dingle points out,

Lorentz ascribes the contraction of rods and slowing down of clocks to an *ad hoc* physical effect of the ether on moving bodies; Einstein ascribes them to an *ad hoc* modification of kinematics at high velocities. Lorentz's theory is impossible without an ether; Einstein's (because of its relativity postulate) is impossible with one. Einstein's theory makes a velocity greater than c logically impossible; Lorentz specifically restricted his theory to 'a system moving with any velocity less than that of light,' and, from the nature of its effects, it must break down well short of that velocity...it makes the 'light barrier' no more necessarily impassable than the 'sound barrier.' Einstein's theory merges space and time into an unimaginable 'space-time'; Lorentz leaves them independent, as in ordinary understanding. The physical consequences of these differences when very high macroscopic velocities are attained are enormous and ominously incalculable" (*Science at the Crossroads*, p. 232).

Still, since Einstein's theory was based on alterations of the basic fabrics of life, it could be said, as J. L. Synge observed in 1956, that the Special Theory of Relativity might be called the theory of the Lorentz transformations. Similarly, Bertrand Russell stated that the "whole of the special theory is contained in the transformations." Essen adds: "Einstein's theory differs from that of Lorentz only in the method of derivation of the transformations...the subsequent mathematical development could be the same in both theories" (*The Special Theory of Relativity: A Critical Analysis*, p. 8).

William Magie, president of the American Physical Society, pointed out one of the obvious ones in 1911. To his scientific constituents he complained:

The principle of relativity accounts for the negative result of the experiment of Michelson and Morley but without an ether how do we account for the interference phenomena, which made that experiment possible?⁵⁸⁶

As we noted earlier, after Galileo and Newton dispensed with a motionless Earth, their followers subsequently had to depend on the ether to give them an absolute and universal frame of reference. After Einstein dispensed with ether, there was no longer any absolute reference point. But no theory can work without some kind of absolute. Even the theory of Relativity needs an absolute to serve as the standard from which all other things are measured. For Einstein, there was only one absolute left, the speed of light. Although it would be like trying to grasp a cloud, the speed of light would have to serve as the giant ruler to measure all things in the universe. Even today astronomers use it today to measure the distance to the stars in “light-years.”⁵⁸⁷ Since for Einstein there was no longer ether to impede light’s speed, light could remain an absolute throughout the whole universe. Hence, the speed of light has been the lynch pin for all of modern physics. As one author put it:

Einstein made space and time relative, but in order to do this he had to take something else, which was the velocity of light, and make it absolute. The velocity of light occupies an extraordinary place in modern physics. It is *lèse-majesté* to make any criticism of the velocity of light. It is a sacred cow within a sacred cow, and it is just about the Absolutest Absolute in the history of human thought. There is a text book on physics which openly says, “Relativity is now accepted as a faith.” This statement, although utterly astounding in what purports to be a science, is unfortunately only too true.⁵⁸⁸

⁵⁸⁶ William F. Magie, “The Primary Concepts of Physics,” *Science*, vol. XXXV, February 23, 1912, as cited in Loyd S. Swenson, Jr., *The Ethereal Ether*, Austin and London, University of Texas, 1972, p. 177.

⁵⁸⁷ A “light year” is the distance light travels in a year at a speed of 299,792,459 meters per second. According to current astronomical theory, the nearest stars, *Proxima Centauri* and *Alpha Centauri*, are 4.3 light-years from Earth.

⁵⁸⁸ Anthony Standen, *Science is a Sacred Cow*, London, Sheed and Ward, 1952, pp. 52-53, referring to the book written by Robert A. Houstoun titled: *Treatise on Light*, Longmans, Green and Co, 1946.

This also meant, of course, that if someday someone discovered that light's speed varied in the same medium, whether faster or slower, it would be the immediate demise of Relativity. (See Appendix 1: "Anomalies Concerning the Speed of Light").

Einstein Invents Special Relativity to Answer the Michelson-Morley Experiment

The only thing with which Einstein now had to contend was how to fit a moving Earth into the Michelson-Morley experiment. The only components left were time and space. Rather than allow the speed of light to vary, Einstein opted to vary time and alter space. In regard to the Michelson-Morley experiment, if the time of the light beam traveling in the direction of the Earth's orbit were reduced, and the space in which it traveled were non-Euclidean, then Einstein could offer an explanation why the beams in the interferometer returned to the same spot at different times.⁵⁸⁹

Essentially, the only thing Einstein did was exchange absolutes. Whereas, prior to Copernicus the absolute was a motionless Earth, and for Galileo and Newton it was a motionless space, for Einstein it became the observer viewing the constant speed of light entering his retina. As Herbert Dingle puts it:

An almost equally effective means of escaping difficulties is the introduction of 'the observer.' When the Einstein theory appears to lead to incompatible objective results, they are written off as merely different *appearances*, but claimed as *realities* when some actual phenomenon has to be explained.⁵⁹⁰

Obviously, if light is the only absolute in the universe yet its speed is finite, Einstein had to compensate for this annoying limitation in some fashion. Thus he postulated that each observer sees the light coming into his eyes as an absolute speed. Virtually every idea and formula surrounding Special Relativity is based on "what the observer sees." More specifically, each "observer" is said to have his own inertial

⁵⁸⁹ Later, when Einstein was incorporating the General Relativity theory and its emphasis on accelerated frames (as opposed to the uniform motion frames of Special Relativity), he would be forced to modify Hermann Minkowski's non-Euclidean geometry into Georg Riemann's non-Euclidian geometry, that is, if the same explanation were to be given to the Michelson-Morley experiment.

⁵⁹⁰ *Science at the Crossroads*, p. 180. For a summation to Einstein's view that in "Relativity: There is no hitching post in the universe – so far as we know," Einstein retorted: "Read, and found correct" (*Einstein: The Life and Times*, p. 521). Of note, Max Planck, a firm supporter of Special Relativity and an equally firm opponent of Ernst Mach's view that "nothing is real except the perceptions," held the ironic position that the basic aim of science is "the finding of a *fixed* world picture independent of the variation of time and people...the complete liberation of the physical picture from the individuality of the separate intellects" (cited in Holton's *Thematic Origins of Scientific Thought*, p. 245, emphasis his). Since Relativity did not give Planck what he desired and, in fact, based everything on the "observer" who had "variation of time" and a "separate intellect," we wonder if he would have been amenable to a "fixed" Earth to satisfy his search. Einstein gave him anything but that.

frame of reference. If there were a million observers to an event, there would be a million inertial frames of reference, and Relativity can create as many observers, and thus inertial frames, as it needs to reinforce its theory.⁵⁹¹

The inordinate creation of an infinite variety of inertial frames relates directly to the heliocentrism versus geocentrism issue. As one modern physics explained the two sides of the debate:

...within a century of Copernicus' death the heliocentric model had been fully accepted by the scientific community....This is because the objections to relativity that had seemed so irrefutable since ancient times could now be answered, but only because of a profound re-interpretation of the relativity principle brought about by the successors of Copernicus, including Kepler, Galileo, Descartes, Huygens, and Newton. These men developed a physically viable theory of relativity based not on purely kinematical relations, but on the dynamical principle of inertia, according to which there exists an infinite class of relatively moving coordinate systems that are all equivalent from the standpoint of mechanical dynamics. The principle of relativity founded on the concept of inertia became the operational basis of the Scientific Revolution.⁵⁹²

Later in the same book, the author attempts to use the “concept of inertia” for at least circumstantial evidence for the Copernican solar system, but in the end he admits that it offers no solid proof:

The historical parallel between Special Relativity and the Copernican model of the solar system is not merely superficial, because in both cases the starting point was a pre-existing theoretical structure based on the naive use of a particular system of coordinates lacking any inherent physical justification. On the basis of these traditional but eccentric coordinate systems it was natural to imagine certain consequences, such as that both the Sun and the planet Venus revolve around a stationary Earth in separate orbits. However, with the newly-invented telescope, Galileo was able to observe the phases of Venus, clearly showing that Venus moves in (roughly) a circle around the Sun. In this way the *intrinsic* patterns of the celestial bodies became better understood, but it was still possible (and still *is* possible) to regard the Earth as stationary in an absolute extrinsic sense. In fact, for many purposes we continue to do just that, but from an astronomical

⁵⁹¹ An inertial frame is the foundation frame, the place of no change. If the foundation is not moving, the law of inertia says it remains motionless; if it is moving, the same law says it remains in motion unless compelled upon by a net external force.

⁵⁹² *Reflections on Relativity*, “Math Pages,” Preface. Internet study course on Special and General Relativity (www.mathpages.com), author’s name not given.

standpoint we now almost invariably regard the Sun as the “center” of the solar system. Why? The Sun too is moving among the stars in the galaxy, and the galaxy itself is moving relative to other galaxies, so on what basis do we decide to regard the Sun as the “center” of the solar system?

The answer is that the Sun is the *inertial* center. In other words, the Copernican revolution (as carried to its conclusion by the successors of Copernicus) can be summarized as the adoption of *inertia* as the prime organizing principle for the understanding and description of nature. The concept of physical inertia was clearly identified, and the realization of its significance evolved and matured through the works of Kepler, Galileo, Newton, and others. Nature is most easily and most perspicuously described in terms of inertial coordinates. Of course, it remains possible to adopt some non-inertial system of coordinates with respect to which the Earth can be regarded as the stationary center, but there is no longer any imperative to do this, especially since we cannot thereby change the fact that Venus circles the Sun, i.e., we cannot change the intrinsic relations between objects, and those intrinsic relations are most readily expressed in terms of inertial coordinates.⁵⁹³

Notice the very clever manner the author seeks to make an impression on his reader so as to convince him that the Copernican model is the true system. We know this is his goal since he stated it very plainly: “so on what basis do we decide to regard the Sun as the “center” of the solar system?” Being an avowed Copernican, he, of course, chooses the sun as his center based on the principle of “inertia” (although he offers no proofs for his choice). Perhaps convicted by his intellectual conscience, however, he then admits it is still “possible to adopt...the Earth...as the stationary center,” but his only excuse for not doing so is that, in his opinion, “there is no longer any imperative to do this,” and as he sees it, having a system of “inertial coordinates” is preferable to having only one inertial point, the Earth, as the center. We must add that the author’s arbitrary choice comes from a 600-page treatise that is saturated with everything from philosophical analysis, to elaborate charts and graphs, to dozens of pages of differential calculus, all very impressive and all seeking to support Special and General Relativity. Although he opens his Preface asserting the correctness of Copernicanism (“...within a century of Copernicus’ death the heliocentric model had been fully accepted by the scientific community....This is because the objections to relativity that had seemed so irrefutable since ancient times could now be answered”), he then admits that neither Newtonian mechanics nor Relativity theory provides

⁵⁹³ *Reflections on Relativity*, “Math Pages,” Internet study course on Special and General Relativity (www.mathpages.com), pp. 523-524, emphasis added, author’s name not given.

him with any proof. Instead, he relies on an old but useful canard from Galileo concerning “the phases of Venus” to convince his reader that heliocentrism is true, a canard we exposed in Chapter 3.

In the end, Einstein’s attempt to base physics on arbitrarily selected inertial systems wherein each observer is his own preferred reference frame is akin to a universe in which, to borrow a cliché, ‘everyone lives in his own little world.’ If there is no immovable Earth, then each observer will act as his own immovable frame, and all the laws of motion will act upon him as if he were an absolute. As D. and S. Birks state:

Einstein theorized...that the movement of light is a mathematical absolute for any circumstance of motion...Where Ptolemy theorized a geocentric universe, Einstein (upon the basis of the Michelson-Morley experiment theorized a “light-centric” universe...In essence, Einstein theorized a “self-centric” universe, where the entire universe of the individual conforms to the individual’s motion.⁵⁹⁴

As Fresnel used his “drag” mathematics rather than physical experiments to dismiss the geocentric implications of the Arago and Airy experiments, Einstein took up the mantle and forged ahead much farther, introducing the complex equations of tensor calculus and non-Euclidean geometry to explain Fresnel’s hitherto unexplainable astral phenomena. As Einstein saw it, Fresnel had “failed” due to his insistence on incorporating ether into the equation, so Einstein had to tweak Fresnel’s equations, while at the same time dismiss the ether. How does one do this? You conveniently rely on the wax nose of your whole theory, “the observer,” to make things fit as they need be. In this case, the velocity of light that went through Airy’s telescope is framed in terms of the “observer”:

“as seen by the observer [it] is changed by the fraction $1 - 1/\eta^2$...No assumption of any ‘dragging’ is involved in the relativity arguments, nor is the existence of an ether even postulated.”⁵⁹⁵

Of course, the obvious question that arises in this situation is: if two observers are moving relative to each other, then the length for one observer as compared to the other should be less by a factor of $1 - 1/\eta^2$, but since there is no preferred observer, this would mean that each

⁵⁹⁴ Internet: babin.net.

⁵⁹⁵ Quoted from *Fundamentals of Optics*, Francis Jenkins and Harvey White, New York: McGraw Hill, 1957, pp. 404-405, cited in *De Labore Solis*, p. 46, emphasis added.

observer must see the other as being shorter, which is an obvious contradiction. Relativity theory attempts to answer this paradox. As Martin Gardner explains it for the student:

For Lorentz and Fitzgerald the contraction was a physical change, caused by pressure of the ether wind. For Einstein it had only to do with the results of measurement...Lorentz and Fitzgerald still thought of moving objects as having absolute “rest lengths.” When the objects contracted, they were no longer their “true” lengths. Einstein, by giving up ether, made the concept of absolute length meaningless. What remained was length as measured, and this turned out to vary with the relative speed of the object and observer...How is it possible for each ship to be shorter than the other? You ask an improper question. The theory does not say that each ship is shorter than the other; it says that astronauts on each ship measure the other ship as shorter.⁵⁹⁶

What, precisely, causes “each ship to measure the other ship as shorter,” Gardner does not explain, except to refer to a “thought experiment” about similar changes in the slowing down of time. He writes:

Imagine that you are looking out through the porthole of one spaceship into the porthole of another ship. The two ships are passing each other with a uniform speed close to that of light. As they pass, a beam of light on the other ship is sent from its ceiling to its floor. There it strikes a mirror and is reflected back to the ceiling again. *You will see the path of this light as a V...* Now suppose that while you clock the light beam on its V-shaped path, an astronaut inside the other ship is doing the same thing. From his point of view, *assuming his ship to be the fixed frame of reference*, the light simply goes down and up along the same line, obviously a shorter distance than along the V that you observed. When he divides this distance by the time it took the beam to go down and up, he also obtains the speed of light. Because the speed of light is constant for all observers, he must get exactly the same final result that you did: 299,800 kilometers per second. But his light path is shorter. How can his result be the same? There is only one possible explanation: his clock is slower.⁵⁹⁷

The problem with Gardner’s explanation, of course, is that there is no possibility of “assuming” that one ship will have a “fixed frame of reference,” since both ships are moving.

Gardner then proceeds to show us another facet of his theory:

⁵⁹⁶ *Relativity Explosion*, pp. 50-51.

⁵⁹⁷ *Relativity Explosion*, pp. 52-53, emphasis added.

Consider, for example, this simple situation. A spaceship, traveling at three-fourths the speed of light, passes overhead going due east. At the same instant another spaceship, also traveling at three-fourths the speed of light, passes overhead going due west. From your frame of reference, attached to the inertial frame of the Earth, the two ships pass each other with a relative velocity of one and one-half times the speed of light. They approach at that speed, move apart at that speed. There is nothing in relativity theory to deny this. However, the special theory does insist that if you were riding on either ship, you would calculate the relative speed of the ships to be less than that of light.⁵⁹⁸

The problems with Gardner's thought experiment are quite evident. First, his own Relativity theory will not allow him to assume that the observer is "attached to the inertial frame of the Earth." Relativity holds that, in addition to the Earth's rotational and translational motion, it is in relative motion to the spaceships, and thus Earth cannot arbitrarily serve as "an inertial frame." Tempting as it may be for him, Gardner cannot use geocentric principles in order to answer the anomalies in his non-geocentric universe.

We find the same kind of pleading explanations in college physics textbooks. In attempting to explain the famous "twin paradox," one text states:

But what about the traveling twin? If all inertial frames are equally good, won't the traveling twin make all the claims the Earth twin does, only in reverse?...They cannot both be right, for after all the spacecraft returns to Earth and a direct comparison of ages and clocks can be made. There is, however, not a paradox at all. The consequences of the special theory of relativity – in this case time dilation – can be applied only by observers in inertial reference frames. The Earth is such a frame (or nearly so), whereas the spacecraft is not.⁵⁹⁹

Once again, the author assumes Earth is an "inertial frame" but the theory of Relativity simply will not allow this choice since all motion is relative. We can sense that even the author himself is a bit hesitant to make the Earth an inertial frame for he adds the qualification "or nearly so." He knows that in his preferred cosmology the Earth is at least understood to be moving through space by its own rotation and translation, not to mention that it is also carried by the sun's movement through the galaxy, and the galaxy's movement through other groups of

⁵⁹⁸ *Relativity Explosion*, p. 62.

⁵⁹⁹ *Physics: Principles with Applications*, fourth edition, Douglas C. Giancoli, New Jersey, Prentice Hall, 1995, p. 757.

galaxies, and so on, *ad infinitum*. For all he knows, compared to some fixed point the Earth could be moving a million miles a minute, which would hardly make it an “inertial frame.” Moreover, the simple fact that the author has made Earth an inertial frame implies the validity of geocentrism and shows that Relativity lacks the ability to solve its own paradoxes without depending on geocentrism.

Second, Gardner’s attempted explanation of the anomaly (which insists: “if you were riding on either ship, you would calculate the relative speed of the ships to be less than that of light”) only misleads the reader. Gardner has already admitted that the *true* relative speed of the ships (as observed from an inertial Earth) is “one and one-half the speed of light.” Obviously, then, a “calculation” by one of the ships that measures a relative speed less than the speed of light is simply an erroneous calculation. It is erroneous because, in order to know the *true* calculation, he must triangulate his measurement of the other ship with the inertial Earth, which will then give him the precise relative speed of his ship compared to the other ship. But Gardner conveniently eliminated the inertial Earth’s part in this “thought experiment” in the second leg of his paragraph.

Relativists are saddled with constant absurdities that arise from their theory. For example, Relativity holds that if a person, moving at the speed of light, is chasing a particle in a light beam ahead of him, the particle will continue to increase its distance from the person at the speed of light; whereas previous to Einstein, it was understood that light’s speed was constant only with respect to the ether, not necessarily the observer. As Einstein himself said:

“If I pursue a beam of light with the velocity c , I should observe such a beam of light as a spatially oscillatory electromagnetic field at rest. However, there seems to be no such thing, whether on the basis of experience or according to Maxwell’s equations.”⁶⁰⁰

But as E. Butterfield wrote to Herbert Ives:

I just can’t see riding on a moon beam at its take-off and having it get 300,000 km. ahead of me in the first second. If that’s what Einstein means by the constancy of the velocity of

⁶⁰⁰ *Autobiographical Notes*, written in 1946, published in 1949, cited in Holton’s *Thematic Origins of Scientific Thought*, pp. 311, 359. Van der Kamp concludes: “And deliberately set against the possibility of an Earth-centered cosmos he [Einstein] has persuaded all those on that score agreeing with him to put their faith in an ontological impossibility. That is: with whatsoever speed we approach or leave a light source, our instruments register the appropriate Doppler shifts but measure the velocity of radiation received as if we are at rest with regard to the source” (*De Labore Solis*, p. 95).

light, then his whole structure falls to the ground as soon as somebody kicks that out, for that is the keystone.⁶⁰¹

Or as John Norton noted:

This thought experiment has proven immensely popular in accounts of the discovery of special relativity. Who could not fail to be charmed by the image of a precocious sixteen year old whose innocent imaginings lay the groundwork for a great discovery? What is rarely mentioned, however, is that the thought experiment does not quite make sense.⁶⁰²

Having rejected an immobile Earth and even the theoretical existence of ether, Relativists can find no other viable solutions to the complexities of macro physics, and thus are more or less forced to their absurd and obtuse position which can only be presented by even more obtuse mathematics.

⁶⁰¹ April 24, 1951, cited in *The Einstein Myth*, p. 136.

⁶⁰² *Einstein's Investigations of Galilean Covariant Electrodynamics Prior to 1905*, John D. Norton, University of Pittsburgh, Dept. of History and Philosophy of Science, Jan. 28, 2004, pp. 28-29. Norton goes on to show the impracticalness of the thought experiment, as well as showing how Maxwell's equations demonstrate that "rapid motion would bring the light to rest...the wave has been brought to rest; it is a frozen sine wave ('spatially oscillating')." Norton adds, however, that "no field law expressed in differential equations can (a) be an emission theory of light; (b) be a Galilean covariant, even with field transformation laws; and (c) characterize light waves by intensity, color and polarization alone." Louis Essen adds: "A thought-experiment...cannot provide new knowledge; if it gives a result that is contrary to the theoretical knowledge and assumptions on which it is based, then a mistake must have been made. Some of the results of [Einstein's] theory were obtained in this way and differ from the original assumptions (Essen 1957, 1963a, 1965, 1969). Einstein himself calls one of the results peculiar, but in fact it must be wrong, since it disagrees with the initial assumptions....The fact that the errors in the theory arise in the course of the thought-experiments may explain why they were not detected for so long" (*The Special Theory of Relativity: A Critical Analysis*, pp. 2-3). Later Essen observes: "...making the velocity of light have the constant value c even to observers in relative motion is comparable to making it a unit of measurement...The contraction of length and the dilation of time can now be understood as representing the changes that have to be made to make the results of measurement consistent" (*ibid.*, p. 6).

A Review of the Problem: Dingle's Critique of Einstein

Since these issues are so important, we should review and flesh them out a bit more. Since Einstein discarded absolute rest and the ether, his only method of filling in the gaps was to make time and space the variables, yet keep light as the constant.⁶⁰³ Dingle writes:

...Einstein's special relativity theory...has nothing to do with time in the sense of "eternity"; it is concerned only with *instants* and *durations*... creating the illusion...that it has something to say...about the *nature* of "time," of the continuum that St. Augustine and Kant and other philosophers have puzzled themselves about. In fact, time, the ever-rolling stream, has no more to do with the existence of clocks than with that of sausages, while time, in Einstein's theory as in physics in general, means only clock-readings. It is because of this confusion that the "experimenters" have left relativity to the "mathematicians"...They are accepted as such, without understanding but with blind trust....It was Minkowski who later took the fatal step of introducing "eternity" into the theory...When once the distinction between eternity, instant and duration is recognized, the general literature of the subject of relativity is seen to be in utter confusion. The writer, quite unaware that the word "time" has different meanings, unconsciously oscillates between them, and the reader, equally unconsciously, becomes the victim of one non sequitur after another, in which he can see no failure of reasoning but yet no possibility of making sense of the conclusion: thus is generated the illusion that relativity is incomprehensible to the ordinary mind....If one spoke of the time (instant) of a distant event...in the absence of any self-evident, necessary way of determining such an instant, Einstein claimed the right to define it in such a way as to save the electromagnetic theory without violating the principle of relativity of motion. Furthermore, he succeeded in discovering such a definition. It was a veritable stroke of genius, but it is most important to notice this. Einstein had not *disproved* Newton's implied requirement that the rate of a clock was not affected by uniform motion; he had only shown it was a necessary requirement, and that, in the absence of evidence to the contrary, and other self-consistent assumption about the effect of motion on the rate of a clock was permissible....⁶⁰⁴

⁶⁰³ The equation takes the form $t' = t - vx/c^2 / \sqrt{1 - v^2/c^2}$.

⁶⁰⁴ *Science at the Crossroads*, pp. 134-136, 145. Harold Nordenson adds that Einstein's fallacy is "the indiscriminate use of the word 'time' in two different meanings which makes his theory untenable from a logical point of view" (*Relativity, Time and Reality*, London: Allen and Unwin, 1969, p. 120). Defending Minkowski in a letter to Dingle, Max Born writes:

Einstein must dilate time because all his “observers” are moving. They all see light, but they all see it at different times, and there is no stationary Earth from which to judge who of the observers has the right time.⁶⁰⁵ As they say, “everything is relative.” Einstein himself said that

“The simple fact that all relations between space co-ordinates and time expressed by the Lorentz transformations can be represented geometrically by Minkowski diagrams should suffice to show that there can be no logical contradiction in the theory [of relativity].”

Dingle responds:

“The error here lies in oversight of the fact that a physical theory must contain not only a mathematical structure but also a correlation between the mathematical symbols and observable quantities: a perfectly logical theory may therefore fail physically in the second of these requirements. This oversight calls for much more general consideration, because it characterizes almost the whole of modern physical theory, in which so often a mathematical possibility is assumed automatically to be a physical possibility also, whereas mathematical symbols have a far wider range of significance than is possible to the physical objects whose properties they are taken to represent. The equations, $8 - 6 = 2$ and $6 - 8 = -2$, are mathematically valid and equivalent examples of the general equation, $a - b = c$. They are both geometrically applicable to a physical situation: thus, if we walk 8 miles north (+) and then 6 miles south (-) we end 2 miles north of our starting point; and if we walk 6 miles north and then 8 miles south we end 2 miles south of our starting point. But they are not both applicable to physical objects: you can get 6 apples from 8 by leaving 2 behind, but you cannot get 8 apples from 6 by leaving -2 behind. If Professor Born’s argument were sound we should be able to say: the simple fact that all numerical values of a , b and c expressed by the equation $a - b = c$ can be represented geometrically by lines drawn to north and south should suffice to show that there can be no logical contradiction (and, by implication, nothing wrong) in the theory that you can get 8 apples from 6” (*Science at the Crossroads*, pp. 231-232).

⁶⁰⁵ The difference in the time between the two observers will be: $1/\sqrt{(1 - v^2/c^2)}$, which is the same equation Lorentz used for time/length contraction, but at least Lorentz was basing his on the fact that the ether constituted absolute time and distance. Einstein had no such luxury. In any case, as Dingle states:

“...the assumption of the Lorentz transformation in mechanics requires one clock to work both faster and slower than another. The fact that this can be seen to be contradictory in advance of observation, whereas the result of the Michelson-Morley experiment could not be foreseen, is due simply to the fact that we already know far more about clocks than about light...and we know enough about clocks to know that one cannot, at the same time and in the same sense, be working both faster and slower than another” (*Science at the Crossroads*, p. 235).

Later he writes:

If Einstein’s theory is valid the following questions arise. How is it possible for the ratio of the intervals recorded by two identically constructed,

regularly running clocks, between the same pair of events, to vary with the events chosen (in other words, how can the ratio of two constant quantities be variable)? Second, if it is possible, why must the events that alone give the ‘correct’ ratio be chosen from the set occurring on one and not the other of the clocks? Third, if they must be so chosen, how does one (consistently with a theory in which the only feature in which the clocks differ – motion – can be ascribed indifferently to one of the other) discover on which clock the valid set of events occurs? I think it is self-evident that these questions are unanswerable. There can be no doubt that, if this criticism of the theory had been made in 1906, it would at once have been seen to be fatal and Einstein would have been the first to acknowledge it, for then reason was the *de facto* as well as the *de jure* arbiter in such a matter. In 1967, however, the obvious has become the inconceivable, and it has to meet the prejudice, independent of reason, that every apparent objection to special relativity is merely evidence of incomprehension and can accordingly be ignored” (*ibid.*, pp. 237-238).

Essen says that Dingle’s objection is correct “if the equations given by Einstein are used” but “the apparent contradiction is avoided [only] if we interchange the symbols.” Essen goes on to comment:

Dingle’s treatment of the problem deserves special mention because he was the first to point out...that the clock paradox result was an actual mistake in Einstein’s paper (Dingle, *Nature*, London 177, 782, 1956). He attributes the mistake to the fact that the Lorentz transformations in two different directions do not commute...he argues more generally that if Einstein’s arguments are valid the result must be symmetrical, and he [Einstein] uses the Lorentz transformations to obtain the result that the moving clock is both faster and slower than the stationary one.

Essen concludes:

...the theory [Einstein’s] consists in a number of contradictory assumptions and adds nothing significant to that of Lorentz....As in the clock-paradox thought experiment, it is implied that the result follows from the time-dilation prediction, but in fact an additional assumption is made which contradicts the relativity principle....It is one of [Einstein’s] basic postulates that two observers in relative motion will obtain the same results from physical measurements, but, as Culwick (1959) has pointed out, no experiment of this kind has ever been performed....Another result often quoted in support of the theory is the variation of the life-time of mesons, the life-time being greater the greater the velocity of the mesons. Again it is an important result, but it cannot be regarded as a confirmation of relativity theory (*The Special Theory of Relativity: A Critical Analysis*, pp. 9, 17-20).

In another article Essen writes:

One of the predictions of the theory was that a moving clock goes more slowly than an identical stationary clock. Taking into account the basic assumption of the theory that uniform velocity is purely relative, it follows that each clock goes more slowly than the other when viewed from the position of the other...there is no way of distinguishing between the two...This result is known as the clock paradox or, since the clocks are sometimes likened to identical twins, one of whom ages more slowly than the other, the twin paradox...Some years later, in 1918, he used another

he based his theory on a “free will...definition of simultaneity,” a definition he said was purely arbitrary and unverifiable.⁶⁰⁶ Relativity attempts to compensate for this anomaly by claiming that each person has his own “frame of reference” for which the laws of motion will always work the same, and thus each observer can consider himself “at rest.” The logical criticism of this solution is to ask: “what frame?” and “what reference?” “Frames” and “references” are convenient words for assuming that there can be some place of absolute measurement against which to measure the frames and references. It seems that Relativity wants it both ways. It wants the observer “at rest” but also declares that he is in motion. In Relativity, everything depends on what “the observer” sees, since he has no stationary Earth upon which to rest and judge all motion in the universe.⁶⁰⁷

Dingle was relentless in pointing out these contradictions in Einstein’s theory. He writes:

It was almost inevitable that this paradox should arise from Einstein’s 1905 paper describing the special theory, from which I quote the following passage:

thought-experiment in an attempt to answer criticisms of the paradox result. One of the clocks again made a round trip, the changes of direction being achieved by switching gravitational field on and off at various stages of the journey, the time recorded by the moving clock was less than that recorded by the stationary clock. The result did not follow from the experiment, but was simply an assumption slipped in implicitly during the complicated procedure. The slowing down of the clocks which he had previously attributed to uniform velocity, acceleration having no effect, he now attributed to acceleration, a line of argument followed in many textbooks. (Louis Essen, “Relativity – Joke or Swindle?” *Electronics and Wireless World*, February 1988, pp. 126-127).

It is worthy to note that Dr. Louis Essen, inventor of the atomic clock, was marginalized for his criticism of Einstein and threatened with loss of tenure if the criticisms persisted. The *London Daily Telegraph* carried this obituary of him in September 1997: “Essen put forward his criticisms so vehemently that he eventually came to be regarded as an anti-Establishment troublemaker. He was even warned that his promotion prospects, and thus his pension, might be affected if he did not desist.”

⁶⁰⁶ *Relativity: The Special and General Theory*, 15th edition, NY: Crown Publishers, 1961, ch. 7, p. 23. See also Arthur Lovejoy’s 1930 article “The Dialectical Argument against Absolute Simultaneity” in which he critiques Einstein’s famous thought experiment of “lightening flashes on the railway embankment” (summary in *The Einstein Myth*, pp. 4-6); Geoffrey Builder, *Australian Journal of Physics* 11 [1958]: 457-480 for a critique on Einstein’s arbitrary simultaneity; See also Arthur Lynch’s, *The Case Against Einstein* (London: Philip Allan, 1932) pp. 120-130 for a comprehensive mathematical and logical critique of Einstein’s simultaneity.

⁶⁰⁷ Clark writes: “As Einstein wrestled with the cosmological implications of the General Theory, the first of these alternatives, the Earth-centered universe of the Middle Ages, was effectively ruled out” (*Einstein: The Life and Times*, p. 267).

“If at the points A and B of [the coordinate system] K there are stationary clocks which, viewed in the stationary system, are synchronous; and if the clock at A is moved with the velocity v along the line AB to B, then on its arrival at B the two clocks no longer synchronise, but the clock moved from A to B lags behind the other which has remained at B by $\frac{1}{2} t v^2/c^2$ (up to magnitudes of fourth and higher order), t being the time occupied in the journey from A to B. It is at once apparent that this result still holds good if the clock moves from A to B in any polygonal line, and also when the points A and B coincide.”

From this it follows that Einstein chose Y as the correct solution, and therefore must have rejected X. But he did not disprove X, which seems to follow from the postulate of relativity which is an integral part of the theory P; hence he did not resolve the paradox.⁶⁰⁸

In other words, because Einstein cannot extricate himself from either A or B he must choose which of the two will remain at rest so that he can judge the movement of the other. Without giving any reason for his choice, Einstein arbitrarily sides with B as his fulcrum, forgetting, apparently, that Relativity will simply not allow such biased choices, much less permit anyone to assume the vantage point of Aristotle's Unmoved Mover.

Probably Dingle's most succinct and easily comprehended criticism of Einstein's Special Relativity comes at the very beginning of his book:

It would naturally be supposed that the point at issue...must still be too subtle and profound for the ordinary reader to be expected to understand it. On the contrary, it is of the most extreme simplicity. According to the theory, if you have two exactly similar clocks, A and B, and one is moving with respect to the other, they must work at different rates, i.e., one works more slowly than the other. But the theory also requires that you cannot distinguish which clock is the 'moving' one; it is equally true to say that A rests while B moves and that B rests while A moves. The question therefore arises: how does one determine, consistently with the theory, which clock works the more slowly? Unless this question is answerable, the theory unavoidably requires that A works more slowly than B and B more slowly than A – which it requires no super-intelligence to see is impossible. Now, clearly, a theory that requires an impossibility cannot be true, and scientific integrity requires,

⁶⁰⁸ *Science at the Crossroads*, pp. 185-186.

therefore, either the question just posed shall be answered, or else that the theory shall be acknowledged to be false.⁶⁰⁹

⁶⁰⁹ *Science at the Crossroads*, p. 17.

Martin Gardner and the Inherent Flaws of Relativity

As we noted earlier, Martin Gardner, a popular writer for the technical magazine *Scientific American*, was a valiant supporter of Einstein, but he admitted that Dingle's critique of Einstein was "the strongest objection that can be made against the paradox."⁶¹⁰ At one point, perhaps without realizing precisely the implications of his statement, Gardner more or less confirms Dingle's objection. Replacing Dingle's "A" and "B" with a spaceship and Earth, respectively, Gardner says:

Dingle's objection still remains, however, because exactly the same calculations can be made by supposing that the spaceship instead of the Earth is the fixed frame of reference. Now it is the Earth that moves away, shifts inertial frames, comes back again. Why wouldn't the same calculations, with the same equations, show that the Earth time slowed down the same way?⁶¹¹

As any honest Relativist would be compelled to do, Gardner was forced to admit that Relativity cannot distinguish between a fixed Earth in a rotating universe or a rotating Earth in a fixed universe:

One could just as legitimately assume the Earth to be fixed and the entire universe, with its great spherical cloud of black-body radiation, to be moving. The equations are the same. Indeed, from the standpoint of relativity the choice of reference frame is arbitrary. Naturally, it is simpler to assume the universe is fixed and the Earth moving than the other way around, but the two ways of talking about the Earth's relative motion are two ways of saying the same thing...⁶¹²

⁶¹⁰ Martin Gardner, *The Relativity Explosion*, New York, Vintage, Random House, 1976, p. 133. This is the revised edition of *Relativity for the Million*, New York: Macmillan Co., 1962, p. 120. Gardner then adds that only General Relativity could and must provide the answer to Dingle's objection (*Relativity Explosion*, p. 137; *Relativity...Million*, p. 122), without offering a suggestion how it possibly could do so. Gardner also admits that "Today, astronomers are skeptical of this confirmation. The difficulties in making precise measurements of star positions during an eclipse are much greater than Eddington supposed, and there have been differences in the results obtained during eclipses since 1919...and we haven't even considered the influence of unconscious bias on the part of astronomers who have preconceived ideas..." (*ibid.*, pp. 113-114). (See Appendix 4: "Do the 1919 Eclipse Photographs Prove General Relativity?" in this volume).

⁶¹¹ *The Relativity Explosion*, p. 135; *Relativity for the Million*, p. 122.

⁶¹² *The Relativity Explosion*, pp. 184-185. On another page Gardner writes: "Do the heavens revolve or does the Earth rotate? The question is meaningless. A waitress may just as sensibly ask a customer if he wanted ice cream on top of his pie or the pie placed under his ice cream" (*ibid.*, p. 87)

This is precisely what happens when men reject divine revelation and depend upon themselves to answer the fundamental questions about things they simply cannot answer – it becomes a confusing hodgepodge of dualism and dichotomies in which man, literally, doesn't know whether he is coming or going. The corollary truth, of course, is that God assures us that He is not the author of confusion,⁶¹³ which leaves only two other possible sources, neither of which is very comforting.

Out of the blue Gardner claims to have a way to distinguish between the two. He claims he can tell us which of Dingle's clocks, A or B, is running slower. The clock stationed on Earth, says Gardner, moves with the Earth, but "when the Earth moves away, *the entire universe moves with it.*"⁶¹⁴ This is an astounding statement from Gardner, not because of its brilliance, but because of its implicit admission that when the pressure mounts Relativity depends upon a manufactured, hypothetical, non-Relativistic fixed point *outside* the universe to determine reality inside the universe! Yet if someone were to suggest to the Relativist that such a fixed point actually exists *inside* the universe, and that we even have experimental evidence to prove it (e.g., Michelson-Morley, *et al*), he will dismiss this evidence as arbitrary, and choose, rather, to dispense with ether than admit the possibility of a fixed Earth.

Again, we see quite clearly that the very theory that was invented in 1905 to dispense with having to admit the possibility of an immobile Earth is the very theory that attempts to use immobility to escape geocentrism. Ironically, the hypothetical island that allows Gardner to peer inside the universe ends up supporting geocentrism, not heliocentrism. For if the Earth, as he says, is moving step-for-step with the universe, then it is an immobile point within the universe, while the spaceship is sauntering away bit by bit. In effect, Gardner has tried to deny geocentrism by means of geocentrism. These are the contradictions inherent in Einstein's theory, but its adherents will continue to pretend such anomalies do not exist. In either case they are trapped and geocentrism is vindicated.

Gardner attempts another means to solve this dilemma:

What if the cosmos contained nothing except two spaceships, A and B? Ship A turns on its rocket engines, makes a long trip, comes back. Would the previously synchronized clocks on the two ships be the same? The answer depends on whether you adopt Eddington's view of inertia or the Machian view of Dennis Sciama. In Eddington's view the answer is "yes." Ship A accelerates with respect to the metric of space-time structure

⁶¹³ 1 Corinthians 14:33; Psalm 109:29 [108:29]; Isaiah 45:15-16.

⁶¹⁴ *The Relativity Explosion*, p. 135; *Relativity for the Million*, p. 122; (emphasis his).

of the cosmos; ship B does not...From Sciama's point of view the answer is "no." Acceleration is meaningless except with respect to other material bodies...the two spaceships. In fact, there are no inertial frames to speak of, because there is no inertia (except an extremely feeble, negligible inertia resulting from the presence of the two ships).⁶¹⁵

We see again Relativity's desire to have it both ways. It dismisses absolute space, ether, and anything else that would give substantive or inertial quality to the vast regions between the heavenly bodies, but it conveniently returns them to the scene in the form of "the metric space-time structure of the cosmos" in order to answer the difficult questions. Einstein, as we will see later in this volume, did much the same in his 1920 paper claiming that his Minkowski-Reimann metric served the same purpose as the ether of pre-Relativistic times. Sciama, as noted above, removed this little 'bit of magic' quite easily.

⁶¹⁵ *Relativity for the Million*, p. 124. Sciama quotes Eddington's objection to Mach: "If the earth is non-rotating, the stars must be going round it with terrific speed [a fact that Gardener has already admitted]. May they not in virtue of their high velocities produce gravitationally a sensible field of force on the earth, which we recognize as the centrifugal force? This would be a genuine elimination of absolute rotation, attributing all effects indifferently to the rotation of the earth, the stars being at rest, or to the revolution of the stars, the earth being at rest; nothing matters except the relative rotation. I doubt whether anyone will persuade himself that the stars have anything to do with the phenomenon. We do not believe that if the heavenly bodies were all annihilated it would upset the gyrocompass. In any case, precise calculation shows that the centrifugal forces could not be produced by the motions of the stars, so far as they are known" (Dennis Sciama, *The Unity of the Universe*, New York, Anchor Books, 1961, p. 113).

The Case of the μ -meson

We see the same sleight-of-hand behind more recent claims that purport to have proven Special Relativity, in this case the activity of the μ -meson or the π -meson. As the story goes, μ -mesons or π -mesons appear when protons from cosmic rays enter the Earth's atmosphere and collide with its molecules. The mesons travel with great speed, but since they are inherently unstable, they will decay before they hit the Earth's surface. Yet many are found near the surface. How can this happen? Relativity's answer is: since moving clocks run slower, there is a time dilation from the point of view of the ground-based observer as he looks at the meson. So from his vantage point, the lifetime of the meson is expanded by the Lorentzian factor and thus many of the mesons will reach the surface.⁶¹⁶

The problem with this explanation, of course, is that identical to the "A or B" paradox Dingle demonstrated, the principle of *role reversal* in Special Relativity will not allow its attempt to secure a preferred frame of reference, namely, the ground-based observer. Relativity purports that time is slowed for the ground-based observer but not the meson-based observer, but this would only be the case if it could somehow be proven that the ground or Earth was immobile, and thus the privileged frame, but it certainly cannot. Again, Relativity, by what appears to be a sort of shell game with the reader, appeals to the principle of a fixed Earth in order to support a relative universe. This paradox demonstrates the hopeless quagmire into which Relativity theory is forced. To speak of "moving clocks slowing down" really means nothing of significance since Relativity neither has a means to prove the object against which the clock is supposedly moving, nor does it have a standard clock from which to judge the time of the moving clock.

Interestingly enough, in the article "The 'Time Dilation' of Mesons Re-Examined," D. T. MacRoberts turns the tables and shows the geocentric results of the meson experiments:

The high-velocity experiments on mesons such as those at CERN, are definite evidence of the mesons' lifetimes functional relationship to their velocity with respect to the Earth, but have nothing whatsoever to do with the "time dilation" of Special Relativity. The experiments also are yet

⁶¹⁶ The Lorentz factor being $\sqrt{1 - v^2/c^2}$. Max Born, for example, regards the particles as π -mesons with a lifetime of about 2×10^{-8} seconds. In order to reach the Earth's surface from a height of 30 km, a speed of $0.99999995c$ is needed. To show the arbitrariness of the claims, Eric Chaisson believes the particles are muons with a lifetime of 2×10^{-6} seconds. But this causes problems since, if the muons travel at $0.994c$, their lifetime is extended by a factor of 9, which gives a lifetime of 18×10^{-6} seconds at $0.994c$ or 2.98×10^5 m, thus allowing them to travel only 5.5km, not the needed 30km.

another “ether-drift” investigation with the usual answer: *the velocity of the Earth with respect to a fundamental frame is zero.*⁶¹⁷

Accordingly, it appears that Einstein himself recognized the critique before Dingle spelled it out for us so simply, but Einstein merely stated the problem without following it to its logical conclusion since, obviously, it would have nullified his whole Relativity theory. He writes:

We see thus that we cannot attribute any absolute meaning to the concept of simultaneity. Rather, two events which, considered from one system of reference, are simultaneous, can, considered from a system moving in relation to the former, not be considered as simultaneous.⁶¹⁸

This admission by Einstein leads us to conclude that his system of variants and constants is, shall we say, completely “relative.” On the one hand, if, due to the Michelson-Morley experiment, one assumes that the Earth is moving and light’s speed always appears the same to all observers, even if some observers are moving, then one will be forced to say that lengths contract and that time dilates. There is no other choice. On the other hand, since the solution is “relative,” one could opt to keep lengths and time constant but change the speed of light. Mathematically

⁶¹⁷ D. T. MacRoberts, *Galilean Electrodynamics*, Sept/Oct 1992, p. 83, emphasis added.

⁶¹⁸ “Zur Elektrodynamik bewegter Körper” (“On the Electrodynamics of Moving Bodies”), *Annalen der Physik*, 17, Sept. 26, 1905, p. 897. Einstein was more or less forced to his conclusions about time dilation due to his “principle of equivalence,” which holds that there is no net difference between gravitational force and acceleration force, and thus both effects will produce the same results. Hence, if clocks slow down in a gravitational field [as is commonly accepted in modern science based on such experiments by Pound and Rebka who used the Mössbauer effect to measure a frequency shift $(f'/f - 1) = (2.57 \nabla 0.20) \times 10^{-15}$ after dropping photons a distance of 22.6 meters (*Physical Review Letters* 4, 337, 1960); or by Vessot, *et al*, who launched a hydrogen maser vertically at 8.5 km/sec, and verified its frequency change as it reached an altitude of 10,000 km. The frequency shift due to gravity was $(f'/f - 1) = 4 \times 10^{-10}$ at the 10,000 km altitude (*Physical Review Letters* 45, 2081, 1980)], the clocks must also slow down when accelerated. The relation between gravitation and acceleration was never proven, just assumed. It was also never proven that the slowing of a clock (e.g., the difference in time kept by a terrestrial atomic clock as opposed to a high-altitude atomic clock; or a high-altitude clock traveling east, as in the Hafele experiment) is due, as Relativity theory holds, to gravity’s distortion of the time-space continuum. Since modern science does not know the cause of gravity, it is futile to base co-equivalence on a factor whose nature is unknown. In fact, under alternative theories of gravity, a more viable explanation of the slowed clock is that it is a local mechanical effect caused either by the higher intensity of gravity and/or the higher density of the spatial medium (e.g., ether) near the surface of the Earth as opposed to high-altitudes). See *Pushing Gravity: New Perspectives on Le Sage’s Theory of Gravitation*, ed. Matthew R. Edwards, Montreal: C. Roy Keys Inc, 2002. In any case, absolute time does not slow. Only the *measured* frequency slows.

speaking, the two solutions are precisely equivalent. In this case, the “relative” nature of Relativity comes back to haunt it. The other solution, of course, is to hold that the Earth is not moving, and the necessity of having to contort light, length or time evaporates. As Van der Kamp rightly concludes:

Not yet in the least verified, *ad hocs* fail to qualify as arguments, let alone as ‘proofs.’ They are by themselves only woolly excuses. Worse: until logically incontrovertible test results in their favour will have come to the fore, the skeletons of Ptolemy, Aristotle and Tycho Brahe still rattle happily in their cupboards.⁶¹⁹

Since modern science has not matured enough to accept Brahe’s option, we are left with the confusion seen in Einstein’s prior quote concerning simultaneity being possible and yet not possible. Thus it will not be surprising to reveal what he once stated about the speed of light – a comment hidden in the file of inconvenient facts by the scientists who find no fault with the dear physicist. As Arthur Lynch revealed in his 1932 book, *The Case Against Einstein*, Einstein himself admitted that his theory of the constancy of light *in vacuo* had to be “modified.” Below, Lynch is quoting Einstein, and gives a brief footnote (which I put in parentheses):

Einstein continues: “In a similar manner we see ‘unmittelbar’ [immediately] that the principle of the constancy of the velocity of light in a vacuum must be modified. For one easily recognizes that the path of a beam of light, relative to K’, must generally be crooked, when the light, with respect to K, moves in a straight line with definite constant velocity.” (What Einstein sees here as ‘unmittelbar,’ he failed to see during the many years when he was insisting on his dogma of the constancy of the velocity of light). The word ‘unmittelbar’ amused me so much that I have taken care to give it in the original German...The whole paragraph is interesting because it goes on to deal with one of the profound discoveries of Relativity, that the velocity of light in reference to a body is the same whether that body be at rest, or in motion towards the source of light!...I notice for the moment that Einstein, having postulated the constancy of light, is content to “modify” it when his own reasoning leads him to contradiction; but he does not touch the previous mode of thought that led him to decree this constancy.⁶²⁰

⁶¹⁹ *De Labore Solis*, p. 39.

⁶²⁰ *The Case Against Einstein*, Arthur Lynch, pp. 209-210. In another place, Lynch writes:

Although Lynch was certainly an anti-Relativist, even the Relativists admit that the speed of light is not always constant *in vacuo*, and they go through the most strained semantic contortions in order to deny it is happening. As always, mathematics comes to the rescue. Clifford Will explains:

The speed of light is indeed the same in every freely falling frame, but we are forced to consider a sequence of such frames all along the light path, and when we do so, we find that the observer at the end of the path determines that the light took longer to cover a given trajectory when it passed near the Sun than it would have had it passed farther from the Sun. Whether or not the observer used the words “light slows down near the Sun” is purely a question of semantics. Because he never goes near the Sun to make the measurement, he can’t really make such a judgment; and if he had made such a measurement in a freely falling laboratory near the Sun, he would have found the same value for the speed of light as in a freely falling laboratory far from the Sun, and might have thoroughly confused himself. All the observer can say with no fear of contradiction is that he observed a time delay that depended on how close the light ray came to the Sun. The only sense in which it can be said that the light slowed down is mathematical: in a particular mathematical representation of the equations that describe the motion of the light ray, what general relativists call a particular coordinate system, the light appears to have a variable speed. But in a different

“To thinkers who have confused time and space and regarded them as of the same category, if not interchangeable, anything is feasible; but the consequences of this transcendental thinking are more remarkable than they have supposed. For velocity is composed of relations between time and space, and since, as they claim, one may be expressed in terms of the other it may be taken as composed of time or, alternatively, of space. But velocity and mass are interchangeable, therefore mass may be composed of time, or alternatively, of space. If mass be expressible by time alone, it acquires a fleeting character which seems to allow the material world to dissolve under our feet; but if it be expressible by space alone our situation is worse, for space, according to the Relativists, has no *point de repère* [registering point or datum point]; it is so empty that we cannot seize upon any *point de repère* to measure the velocity of light or to fix its position; it is void, absolutely, what we call void; and so therefore is mass!” (*ibid.*, p. 140). In the 1940-50s, Hebert Ives wrote extensively on the “self-contradictory” nature of Einstein’s principle of the constancy of the speed of light (*Proceedings of the American Philosophical Society* 95: 125-131, 1951; *Journal of the Optical Society of America* 38: 879-884, 1948; 27: 263-273, 1937).

mathematical representation (a different coordinate system), this statement might be false.⁶²¹

Concerning a similar perspective on light, Charles Lane Poor reveals that Relativity's postulates

Indicate that light travels with different speeds in different directions, that the velocity of light depends upon the direction of transmission. That such a mathematical result represents the facts of nature is highly improbable, for in free space there is no difference between right and left, between north and south, or east and west; there is no reason why a ray of light should travel faster to the north than to the south. To overcome this mathematical difficulty, or inconvenience, as he calls it, the relativist makes a substitution, or approximation. Instead of using the direct distance between the centers of two particles of matter, the relativist adds a small, a very small, factor to this distance; or, as Eddington puts it, "we shall slightly alter our co-ordinates." Such an approximation is very common among physicists: it is done every day to simplify troublesome formulas. The only precaution necessary in such a procedure is to remember always that the final result is necessarily approximate, and, before drawing any conclusion, to thoroughly test the effects of the approximation.⁶²²

How would the non-constancy of the speed of light affect Relativity theory? One will be surprised to hear this, but, according to one of Einstein's letter's to Paul Ehrenfest, it would not do any damage. He writes: "I certainly knew that the principle of the constancy of the velocity of light is something quite independent of the relativity postulate."⁶²³ We can only say that it is amazing to watch the contortions through which Einstein puts his own theory.

⁶²¹ Clifford Will, *Was Einstein Right?* pp. 112-113. Will goes on for six more pages using charts, diagrams and more math to convince the reader that his above paragraph actually makes sense.

⁶²² Charles Lane Poor, "Relativity: An Approximation," Paper presented to the American Astronomical Society, Thirteenth Meeting, 1923, Mount Wilson Observatory, California, p. 3. Later Poor states: "But the method is faulty and contains obvious errors, and the fundamental formula for the velocity of light, upon which the entire method is based, is in direct contradiction to the principle of equivalence, for it shows that the speed of light *decreases* as it approaches the sun, while the equivalence principle demands that such velocity should increase" (*ibid.*, p. 12). For Poor's complete paper, which makes a detailed critique of Einstein's prediction of the perihelion of Mercury and the bending of starlight near the sun, see Appendix 4.

⁶²³ Einstein to Ehrenfest, June 3, 1912, Doc. 404, 409, in Papers, vol. 5, cited in "Einstein's Investigations of Galilean Covariant Electrodynamics Prior to 1905," John D. Norton, University of Pittsburgh, Dept. of History and Philosophy of Science, Jan. 28, 2004, p. 24. Norton goes on to show how Wilhem de Sitter debunked Einstein's hypothesis requiring the need for light's constancy in order to produce shadows; and

the fallacy of Einstein's claim that there were no differential equations to account for the "many velocities" of light (pp. 25-27). Dingle, however, critiques de Sitter's "proof" of the constancy of light (and which Einstein cites in his co-authored book *The Evolution of Physics* in 1938) as determined by binary stars. He writes: "The point to be decided, then, is said to be whether the two beams of light emitted towards the Earth by the components at an instant when one is approaching and the other receding from the Earth with velocity v , travel to the Earth with the single velocity c , or with velocities $c + v$ and $c - v$, respectively." Einstein's second postulate argues that unless the light traveled at a constant velocity of c then "an Earthbound observer would therefore see a hopeless confusion of light from the two components, bearing no resemblance at all to the orderly revolution that would actually be taking place." Dingle concludes:

This is, I think, the most remarkable example in the history of science of the wish fathering the thought – with the possible exception of the 'proofs,' following the Copernican heresy, that it was the Sun, and not the Earth, that moved, to which, in fact, this argument bears some resemblance. A finite velocity, of course (and it is not disputed that light in *vacuo* has a finite velocity) must be measured with respect to some standard, and if we do not accept...that the standard is empty space...the only alternative with any claim to consideration is that the velocity c is maintained with respect to the emitting body. But all that de Sitter's arguments disproves is that the velocity is maintained constant with respect to the Earth, for it is with respect to the Earth that the velocities $c + v$ and $c - v$ are reckoned, and surely no one in his senses would now maintain that the Earth provided a standard of rest for all the light in the universe...these observations tell us precisely nothing to enable us to choose between Einstein's postulate...and the postulate that light keeps a constant velocity with respect to its own source (which was proposed in 1908 by Ritz as an alternative to the Maxwell-Lorentz view, but he died before de Sitter's argument was conceived). How could such a simple fact have escaped notice for half a century? It was pointed out several years ago, and universally ignored – which is to me inexplicable on any other grounds than the universal inability of present-day physical scientists to believe that any criticism of special relativity that they cannot answer can proceed from anything but misunderstanding, which entitles them to ignore it (pp. 205-207).

Einstein Reinterprets Maxwell's Equations

All the foregoing aside, Einstein does reveal another primary motivator that caused him to invent his Special Relativity theory. It appears in various places, but particularly in a December 19, 1952 letter that Einstein wrote to Shankland:

The influence of the crucial Michelson-Morley experiment upon my own efforts has been rather indirect. I learned of it through H. A. Lorentz's decisive investigation of the electrodynamics of moving bodies (1895) with which I was acquainted before developing the Special Theory of Relativity. Lorentz's basic assumptions on an ether at rest seemed to me not convincing in itself and also for the reason that it was leading to an interpretation of the result of the Michelson-Morley experiment which seemed to me artificial. What led me more or less directly to the Special Theory of Relativity was the conviction that the electromotive force acting on a body in motion in a magnetic field was nothing else but an electric field. But I was also guided by the result of the Fizeau experiment and the phenomenon of aberration.⁶²⁴

So, if the chief motivator for Einstein to invent Relativity theory was the anomaly he saw between electromagnetism and mechanical motion, perhaps the following quote can be interpreted such that the Michelson-Morley experiment cemented in Einstein's mind the issues raised by the Fizeau and Airy experiments on the one hand, and Maxwell's theory of electromagnetism on the other:

It is no doubt that Michelson's experiment was of considerable influence upon my work insofar as it strengthened my conviction concerning the validity of the principle of the Special Theory of Relativity.⁶²⁵

For Einstein there was an intimate connection between the laws of electrodynamics and the Michelson-Morley type experiments. He made this connection in his famous 1905 paper:

Examples of this sort [anomalies in electro-magnetic correspondence], together with the unsuccessful attempts to discover any motion of the Earth relative to the 'light medium,' suggests that the phenomena of electrodynamics as well as of

⁶²⁴ R. S. Shankland, *Conversations with Albert Einstein*, p. 48, cited in Holton, p. 303, with Holton's interpolations omitted.

⁶²⁵ In an interview on March 17, 1942, with Albert Michelson's biographer (*Einstein: The Life and Times*, p. 128).

mechanics possess no properties corresponding to the idea of absolute rest.⁶²⁶

Rather than deduce from these “unsuccessful attempts” that the Earth was motionless, Einstein was forced, by the prevailing scientific consensus to the only other conclusion – there was no “absolute rest,” and this became the fundamental postulate of Relativity theory. If there were no absolute rest for macro-objects (such as Earth), Einstein hypothesized, at least in mathematical terms, there would be none in the micro-world (e.g., electricity and magnetism). In the very first sentence of his 1905 paper Einstein writes:

It is known that Maxwell’s equations of electrodynamics – as usually understood at the present time – when applied to moving bodies, leads to asymmetries which do not appear to be inherent in the phenomena.⁶²⁷

In other words, although Maxwell’s equations are different from one another, the actual phenomenon they represent is the same. In particular, Einstein is referring to the fact that [Maxwell](#) created one equation for finding the electromotive force produced in a conductor moving past a stationary magnet, but another equation for a magnet moving past a stationary conductor, even though both movements produced precisely the same current, a fact already known since the experiments of Faraday in 1831.⁶²⁸ As Einstein puts it:

⁶²⁶ Zur Elektrodynamik Bewegter Körper (“On the Electrodynamics of Moving Bodies”), *Annalen der Physik*, Vol. 17, 1905, p. 37. Also cited in *On the Shoulders of Giants* by Stephen Hawking, Phila., Running Press, 2002, p. 1167.

⁶²⁷ Zur Elektrodynamik Bewegter Körper (“On the Electrodynamics of Moving Bodies”), *Annalen der Physik*, Vol. 17, 1905, p. 1. As Herbert Dingle describes it: “...the whole of Einstein’s special theory, as set out in his paper of 1905...treats of the relations between observable things in different ‘coordinate systems’; i.e., apart from trivial differences, it deals with the values which those things take when the observable physical system under consideration is regarded as having different states of uniform motion. It is a problem that had been considered for centuries and regarded as solved until an ambiguity arose when it was found that the relations accepted with the events treated in mechanics were incompatible with those which seemed to be demanded with the events treated in electromagnetism. Einstein’s theory was designed to provide a relation that held for both kinds of events.” (*Science at the Crossroads*, p. 137). See also L. P. Fominskiy in “The Concept of an Interval: A Basic Mistake of the Theory of Relativity” (*Spacetime and Substance*, Vol. 3, 2002, No. 2, 12, pp. 49-54). Holton remarks that Einstein’s use of “asymmetries” seems out of place, at least until we consider the philosophical ramification of its meaning.

⁶²⁸ Maxwell had four equations: (1) $\delta E = 4\pi\rho$ (2) $\delta\Xi = 0$ (3) $\delta\Xi = 4\pi j/c + 1/c \delta E/\delta t$ (4) $\delta E = -1/c \delta\Xi/\delta t$. Ξ is the magnetic field; j is the current flux; ρ is the charge density; E is the electric field. The two equations of interest here are (3) and (4), since they give different equations for finding the change in the magnetic field (equation 3) as opposed to the change in the electrical field (equation 4).

Take, for example, the reciprocal electrodynamic action of a magnet and a conductor. The observable phenomenon here depends only on the relative motion of the conductor and the magnet, whereas the customary view draws a sharp distinction between the two cases in which either the one or the other of these bodies is in motion. For if the magnet is in motion and the conductor at rest, there arises in the neighborhood of the magnet an electric field with a certain definite energy, producing a current at the places where parts of the conductor are situated. But if the magnet is stationary and the conductor in motion, no electric field arises in the neighborhood of the magnet. In the conductor, however, we find an electromotive force, to which in itself there is no corresponding energy, but which gives rise – assuming the equality of the relative motion in the two cases discussed – of electric currents of the same path and intensity as those produced by the electric form in the former case.⁶²⁹

The conventional way of explaining this phenomenon was the following: if the conductor is moving toward a stationary magnet, the electrical charge in the conductor is pulled around the conductor by the force of the magnetic field. Conversely, if the magnet is moving toward the conductor, the increasing magnetic field produces an electric field that drives the charge around the conductor. Einstein apparently did not like this explanation. The reason is noted in the parenthetical statement he adds toward the end of the above paragraph: “...assuming the equality of the relative motion in the two cases discussed...” If the “relative motion” is the same in both cases (that is, a conductor moving toward a stationary magnet or a magnet moving toward a stationary conductor are identical), Einstein assumed that the results should be identical, that is, in both cases the current produced should either always be around the magnet or always around the conductor, and not switch between the magnet and the conductor. Since the results were not identical, Einstein sought to find a reason, but he would do so assuming the principle of Relativity.⁶³⁰

⁶²⁹ Zur Elektrodynamik Bewegter Körper (“On the Electrodynamics of Moving Bodies”), *Annalen der Physik*, Vol. 17, 1905, p. 1.

⁶³⁰ At this point, one must acknowledge that the electromagnetic field in Relativity is not merely two separate vectors (electricity and magnetism) but as components of a 4-dimensional tensor, such that a change in velocity is represented by the 4-dimensional rotation of the tensor. In any case, we would do well to pause here and remind ourselves that the difficulty that both Maxwell and Einstein faced was that neither of them knew the nature of the physical reality. They merely explained the results by mathematical equations. As mathematician Morris Kline states: “What is especially remarkable about electromagnetic waves...is that we have not the slightest physical knowledge of what electromagnetic waves are. Only mathematics vouches for their existence...The same observation applies to all sorts of atomic and nuclear phenomena. Mathematicians and theoretical physicists speak of fields – the gravitational field, the

Before we move on to discover how Einstein attempted to solve this problem, we can pause to point out that the relationship between the magnet and the conductor is either analogous to the situation in Machian cosmology (and a cosmology to which Einstein agreed) wherein a rotating Earth in a stationary universe appears to be the same as a stationary Earth in a rotating universe. Since between the conductor and the magnet there seems to be a preferred place the electric current seeks depending on whether the conductor or the magnet is moving against the other, we would likewise say that there is also a preferred cosmology between the Earth and the universe, that is, of the two Machian cosmologies (a fixed Earth or a fixed universe) it would seem correct to postulate that the principles of the relation between electricity and magnetism discovered by Maxwell (and/or the principle between gravity and inertia), will reveal which of the two cosmologies is correct. After all, Einstein himself extrapolated principles from the results of the small-scale electromotive model and transferred them to the large-scale cosmological model, for, by his own admission, this is precisely the connection he saw between Maxwell's equations and the Michelson-Morley experiment.⁶³¹

Seeking support for Relativity, and having a vested interest to deny the Earth as the immovable frame of reference, Einstein will seek to explain both the Maxwell and the Michelson-Morley phenomena purely from a Relativistic standpoint, wherein it makes no difference whether the magnet or the conductor is at rest, or whether the Earth or the universe is at rest. Although a perfect solution to the contradictions created when kinematics and electromagnetism are mixed is a fixed Earth, Einstein's was not about to accept that proposal. Instead he insisted that there will be "no absolute rest." In essence, this is the principal reason Einstein wants to eliminate the ether, since, as Maxwell's equations and Michelson-Morley's experiment dictate, ether will help us to choose which frame of reference is correct. The evidence, freely admitted but "ruled out" by Einstein, showed that the preferred frame of reference was a fixed Earth.

This solution is also admitted, in a roundabout way, by standard physics textbooks. As one text states:

However, it appeared that Maxwell's equations did not satisfy the relativity principle. They were not the same in all inertial reference frames... Thus, although most of the laws of physics

electromagnetic field, the field of electrons, and others – as though they were material waves which spread out into space and exert their effects somewhat as water waves pound against ships and shores. But these fields are fictions. We know nothing of their physical nature" (Morris Kline, *Mathematics: The Loss of Certainty*, p. 337).

⁶³¹ As quoted above: "the unsuccessful attempts to discover any motion of the Earth relative to the 'light medium,' suggests that the phenomena of electrodynamics as well as of mechanics possess no properties corresponding to the idea of absolute rest."

obeyed the relativity principle, the laws of electricity and magnetism...apparently did not. Instead, they *seemed to single out one reference frame that was better than any other – a reference frame that could be considered to be absolutely at rest.*⁶³²

Another text adds:

“A more formal way of saying this is as follows: Maxwell’s equations of electromagnetism...contain the constant $c = 1/\sqrt{(\mu_0\epsilon_0)}$ which is identified as the velocity of propagation of a plane wave in vacuum...But such a velocity cannot be the same for observers in different inertial frames, according to the Galilean transformations, so Maxwell’s equations and therefore electromagnetic effects will probably not be the same for different inertial observers. But if we accept both the Galilean transformations and Maxwell’s equations as basically correct, *then it automatically follows that there exists a unique privileged frame of reference...in which Maxwell’s equations are valid and in which light is propagated at a speed $c = 1/\sqrt{(\mu_0\epsilon_0)}$.*”⁶³³

Einstein certainly had his problems to solve. If he was not going to accept a fixed Earth or ether, he then had to figure out how to deal with the two of Maxwell’s equations that contained the speed of light. As noted above, the equations did not allow the speed to change (although Maxwell did not specify a vector to the electromagnetic field, rather, he merely said that the field moved with respect to the ether). He also had to solve the paradox of Maxwell’s equations with the Galilean understanding of space (also known as “Galilean Relativity”), which says that if a stationary person observes a moving object, then a second person who is in motion will observe a different velocity for the same object. In regards to the velocity of light, this means that the source’s velocity or the observer’s velocity will add to or subtract from the velocity of light. But Maxwell’s equations say each person will see the

⁶³² Douglas C. Giancoli, *Physics: Principles with Applications*, Englewood Cliffs, NJ, Prentice-Hall, first edition, 1980, p. 621; fifth edition, 1998, p. 795, emphasis added. Giancoli adds: “The question then arose: In what reference frame does light have precisely the value that is predicted by Maxwell’s theory? For it was assumed that light, like other objects, would have a different speed in different frames of reference. For example, if an observer were traveling on a rocket ship at a speed of 1.0×10^8 m/s toward a source of light, we might expect that he would measure the speed of the light reaching him to be 3.0×10^8 m/s + 1.0×10^8 = 4.0×10^8 m/s. But Maxwell’s equations have no provision for relative velocity. They merely predicted the speed of light to be $c = 3.0 \times 10^8$ m/s. This seemed to imply that there must be a special reference frame where c could have this value” (*ibid*).

⁶³³ Robert Resnick and David Halliday, *Basic Concepts in Relativity and Early Quantum Theory*, New York, John Wiley and Sons, 1985, p. 12, emphasis added.

same velocity. But no observed phenomena violated either Galilean or Maxwellian space, yet the theoretical contradiction between the two was apparent. It seemed there was one set of velocity rules for mechanics, and another set for electrodynamics.⁶³⁴

The first attempt to solve this problem was to postulate that Maxwell's equations are true only with respect to the ether, not the observer. Since waves need a medium to propagate (e.g., sound waves, water waves), ether was the natural solution.⁶³⁵ From Maxwell's perspective, the ether will react differently with a moving magnet than it will with a stationary magnet, but it will adjust for the discrepancy by producing the same electric current. This takes into account that magnetism is velocity dependent, and thus, directionally dependent within its absolute, the ether. Magnetism has no relationship to relative velocities. As such, magnetism has been the death knell for every cosmological perspective that failed to see the Earth as immobile, including Galilean relativity, Newtonian relativity and Einsteinian relativity.⁶³⁶

Still, Einstein did not like the "asymmetry" of two different equations, even though they produced the same result. As he did to explain the results of the Michelson-Morley experiment, Einstein's solution to Maxwell's equations was to eliminate both the ether and absolute motion (the absolute motion of the magnetic field in the ether). This allows one to "relativize" the components so that one equation can be used for both cases. He makes this very suggestion in one of the last sentences of the Introduction to his 1905 paper:

The introduction of a "luminiferous ether" will prove to be superfluous inasmuch as the view here to be developed will not require an "absolutely stationary space" provided with special properties, nor assign a velocity-vector to a point of the empty space in which the electromagnetic processes take place.⁶³⁷

⁶³⁴ Equations 3 and 4 contain c in the denominator, which remains constant: (3) $\delta\Xi = 4\pi j/c + 1/c \delta E/\delta t$ (4) $\delta E = -1/c \delta\Xi/\delta t$.

⁶³⁵ That Maxwell was a firm believer in the ether medium is noted in the following quote from him: "The interplanetary and interstellar spaces are not empty, but are occupied by a material substance or body, which is certainly the largest, and probably the most uniform body of which we have any knowledge" (*Scientific Papers of James Clerk Maxwell*, New York: Dover Publications, 1965, "Ether," p. 775).

⁶³⁶ Magnetism, as opposed to gravity and electricity, is velocity dependent [$E = v\Xi$]. The force of magnetism is: $F = q_1q_2v_2 \times (v_1 \times r)/r^2$, where q = the electric charge.

⁶³⁷ Zur Elektrodynamik Bewegter Körper ("On the Electrodynamics of Moving Bodies"), *Annalen der Physik*, Vol. 17, (1905, p. 2, as cited in *The Principle of Relativity: A Collection of Original Memoirs on the Special and General Theory of Relativity* by H. A. Lorentz, A. Einstein, H. Minkowski and H. Weyl, translated by W.

The reader must understand the bind in which Einstein has found himself: (a) the Michelson-Morley experiment has provided him with evidence that the Earth is not moving through ether, and (b) the property of magnetism requires that it be understood as a velocity-vector phenomenon, but neither (a) nor (b) are “relativistic” events. But since Einstein believes a moving Earth is already proven, then he must find a radical solution that will allow him to dispense with a motionless Earth and the vector-dependent state of magnetism. Einstein’s solution, of course, is to do away with “absolute rest” altogether. Hence, there would be no fixed Earth, no fixed universe, no fixed magnet and no fixed conductor. All are in relative motion and there is no fixed frame of reference. It was the only way out of the dilemma. Either that, or Einstein would have to tell the world that Copernicus should have remained a devout canon rather than becoming a cosmologist. As Dingle recounts it in terms of his famous Cheshire cat:

...this was a direct contradiction of Maxwell’s basic axiom...What Einstein was proposing, therefore, was to retain the finite velocity of light without the existence of any standard with respect to which that velocity had a meaning. Light consisted of waves, with a definite length, frequency and velocity, in nothing; it was the grin without the Cheshire cat...the fact that it could have been proposed at all is inexplicable until we remember the nature of the acceptance...so well expressed by Hertz – ‘Maxwell’s theory is Maxwell’s system of equations.’ The physical part of the theory was expendable; only the equations needed to be saved. Einstein saw a way of saving the equations, and did not consider it worthwhile to ‘explain’ light...If his assumptions were granted he did save the equations, and when his theory ultimately made its general impact on the world, mathematics had so dominated physics that the non-existence of the Cheshire cat was regarded as a triviality; the grin remained, and all was well.⁶³⁸

So here was another case in which mathematics ruled. As long as a temporary solution could be proffered by a mathematical equation, science would accept it and hope to figure out the actual physics sometime later (but never did). Einstein’s math allowed him to relativize all the physical components, and thus he turned the separate components of electricity and magnetism into “electromagnetism”; he turned the separate components of space and time into “space-time”; and he would then turn the components of acceleration and gravity into the one

Perrett and G. B. Jeffery from the original 1923 edition, Dover Publications, 1952, p. 38).

⁶³⁸ *Science at the Crossroads*, pp. 155-156.

phenomenon of the “inertio-gravitational field,” all by means of mathematical equations of which he himself admitted he didn’t know whether they represented reality.⁶³⁹ Combining the entities in a mathematical formula, however, seemed easier than treating them separately. “Spacetime’s” originator was [Hermann Minkowski](#). He writes:

The views of space and time which I wish to lay before you have sprung from the soil of experimental physics and therein lies their strength. They are radical. Henceforth space by itself and time by itself are doomed to fade away into mere shadows, and only a kind of union of the two will preserve an independent reality.⁶⁴⁰

Indeed, they were “radical.” So radical that they didn’t make a bit of sense. Not even the mathematics could be called upon to make it work. As he did with Einstein’s theory, Charles Lane Poor shows the fallacies of the Minkowski math:

Let us turn for a moment to some tenets that preceded the Einstein Theory of Relativity and led up to it. First comes the gloomy forecast of Minkowski that ‘From henceforth [1908] space in itself and time in itself sink to mere shadows and only a kind of union of the two remains independent.’ The layman is puzzled to know just what this sinking of space and time into mere shadows means, as also just what the union product is, and why the union has independence when its constituents have none.⁶⁴¹

After instructing the reader on the Pythagorean theorem concerning the length of the hypotenuse (D) of right triangle, such that $D^2 = x^2 + y^2$ or $D = \sqrt{x^2 + y^2}$, Poor expands to $D = \sqrt{x^2 + y^2 + z^2}$ to show how the same principle applies to three dimensions. He writes:

⁶³⁹ One of Einstein’s more famous quotes is: “As far as the laws of mathematics refer to reality, they are not certain; and as far as they are certain, they do not refer to reality” (*Sidelights on Relativity*, Dover Publications, 1983, p. 28). Other quotes along these same lines are: “Do not worry about your problems with mathematics, I assure you mine are far greater”; “Mathematics are well and good but nature keeps dragging us around by the nose.”

⁶⁴⁰ From Minkowski’s September 21, 1908 “Raum und Zeit” (“Space and Time”) lecture in Cologne to the 80th Assembly of German Natural Scientists and Physicians, cited in *The Principle of Relativity: A Collection of Original Memoirs on the Special and General Theory of Relativity* by H. A. Lorentz, A. Einstein, H. Minkowski and H. Weyl, translated by W. Perrett and G. B. Jeffery from the original 1923 edition, Dover Publications, 1952, p. 75.

⁶⁴¹ *Gravitation versus Relativity*, p. xviii.

This equation, therefore, represents a definite, fundamental relation between the coordinates of point in ordinary space: the distance [D] is the same, no matter upon what system the individual measures are made. In the terms of the mathematician, D is *invariant*. Now Minkowski showed that, when the Lorentz transformation equations are used, there is a similar *invariant* quantity connecting the four coordinates necessary to locate an event in space and time. This quantity is $D' = \sqrt{(x^2 + y^2 + z^2 + c^2 t^2)}$ where c is the velocity of light and t , the interval of time between two events, and x, y, z , the ordinary three distance coordinates. Now Minkowski showed that, no matter in what direction the measures are made, no matter what system of coordinates be used, then D' always has the same value; it is *invariant*, absolute, and thus furnishes a definite and fixed relation between the space coordinates and the time coordinate....This mathematical expression of Minkowski for a space-time interval corresponds closely to our ordinary expression for the distance between two objects, but not exactly. The term involving the time is preceded by a minus sign instead of a plus sign. The correspondence, however, can be made complete, if the time coordinate, ct , is replaced by the imaginary quantity $ct \times \sqrt{-1}$. This is a mathematical symbol for an imaginary quantity, for something we can neither visualize, nor conceive of. It is useless to attempt to illustrate or visualize the connection between time and space; the very mathematical symbol used to denote the form of the connection indicates the impossibility of our doing so. Thus the very mathematical symbol, used by the followers of relativity, indicates the purely imaginary character of all their reasoning. From these postulates and principles Einstein has built up his entire theory of relativity.⁶⁴²

⁶⁴² *Gravitation versus Relativity*, pp. 40-44.

Einstein Invents General Relativity for the Failure of Special Relativity

Einstein's quest was to make Maxwell's equations work with no ether. This is not a small task, since Maxwell's equations depend explicitly on ether. As Herbert Dingle writes:

...Einstein's relativity theory, designed to save Maxwell's equations, could do so only by sacrificing the ether which was the basis of Maxwell's theory....Einstein, as he said [see pp. 159-60 of Arthur Eddington's *The Mathematical Theory of Relativity*], designed his theory to conform to the Maxwell-Lorentz electromagnetic theory which he accepted as equivalent to "certain."⁶⁴³

One of the ironies in this whole escapade of Einstein's resorting to his "relativistic" solution to solve Maxwell's equations is that he knew of another "thought" experiment that employed a non-relativistic solution, but refused to consider using it. As one physicist put it:

But one can readily construct other thought experiments in which the observables do depend on absolute motions – or that they actually do not require exploitation of the full apparatus developed by Lorentz that gets its final expression in Einstein's theory of relativity. That there were other problematic thought experiments readily at hand had been pointed out clearly by August Föppl (1894)...⁶⁴⁴

⁶⁴³ *Science at the Crossroads*, pp. 133, 142. Lorentz was using his "transformation" equations to solve the problems presented by Maxwell's equations, and the Fizeau, Airy and Michelson-Morley experiments. In his work *Versuch* (1895), Lorentz develops his idea of "corresponding states" so that one can transfer back and forth between Maxwell's equations and Fizeau's "partial drag," Airy's stellar aberration, and Michelson-Morley's "null" results of Earth's movement through the ether. In each case, Lorentz, because he assumes the Earth is moving 30 km/sec, must dilate time and shorten lengths to make things fit.

⁶⁴⁴ "Einstein's Investigations of Galilean Covariant Electrodynamics Prior to 1905," John D. Norton, University of Pittsburgh, Dept. of History and Philosophy of Science, Jan. 28, 2004, p. 8. Gerald Holton makes a convincing case that Einstein was very familiar with Föppl's arguments but rarely mentioned Föppl's name (*Thematic Origins of Scientific Thought*, pp. 218-225). Föppl based his "thought" experiment on two adjacent charges, at rest and in motion. Norton argues that "The result is that the forces acting and thus the motions resulting would allow a co-moving observer to distinguish whether the pair of charges is moving through the ether or is at rest." In a full appendix he concludes that "the principle of relativity fails for the observables in the case of the two charges" and that "Maxwell's equations (M1) and (M3) are all that is needed to compute the original field and the new magnetic field arising when the charges are set in motion" (pp. 9, 53-54). In his analysis, Föppl admits the insurmountable difficulty of a science which has "no recourse to an absolute motion in space since there is absent any means to find such a motion if there is no reference object at hand from which the motion can be observed and measured." This, of course, is precisely the argument of

In order to conceptualize his theory, Einstein created one of his famous *Gedankenexperimenten* (i.e., thought experiments), which reveals keen insights to his thinking process, as well as the connection between Special and General Relativity. In a newly discovered handwritten explanation titled *General Relativity Theory*, he writes:

According to Faraday, during the relative motion of a magnet with respect to a conducting circuit, an electric current is induced in the latter. It is all the same whether the magnet is moved or the conductor; only the relative motion counts, according to the Maxwell-Lorentz theory. However, the theoretical interpretation of the phenomenon in these two cases is quite different.

The thought that one is dealing here with two fundamentally different cases was for me unbearable. The difference between these two cases could not be a real difference but rather, in my conviction, only a difference in the choice of the reference point. Judged from the magnet, there were certainly no electric fields, [whereas] judged from the conducting circuit there certainly was one. The existence of an electric field was therefore a relative one, depending on the state of motion of the coordinate system being used, and a kind of objective reality could be granted only to the *electric and magnetic field together*, quite apart from the state of relative motion of the observer or the coordinate system. The phenomenon of the electromagnetic induction forced me to postulate the (special) relativity principle. The difficulty that had to be overcome was in the constancy of the velocity of light in vacuum which I had first thought I would have to give up. Only after groping for years did I notice that the difficulty rests on the arbitrariness of the kinematical fundamental concepts.

When, in the year 1907, I was working on a summary essay concerning the special theory of relativity...I had to try to modify Newton's theory of gravitation in such a way that it would fit into the theory [of relativity]. Attempts in this direction showed the possibility of carrying out this enterprise, but they did not satisfy me because they had to be supported by hypotheses without physical basis. At that point, there came to me the happiest thought of my life, in the following form:

geocentrism at the core. Föppl holds that the ether "question forms perhaps the most important problem of science of our time" (*Einführung in die Maxwellsche Theorie der Elektrizität*, pp. 307-309, Leipzig: B. G. Tuebner, cited in Holton, *Thematic Origins of Scientific Thought*, pp. 221, 235).

Just as is the case with the electric field produced by electromagnetic induction, the gravitational field has similarly only a relative existence. *For if one considers an observer in free fall, e.g., from the roof of a house, there exists for him during his fall no gravitational field – at least in his immediate vicinity.*⁶⁴⁵

We see that the General Theory of Relativity was already in the works as early as 1907, and both it and the Special Theory of Relativity were created by “thought” experiments, with little, if any, physical proof for their validity. The only “proof” Einstein had at his disposal in 1907 were the results of the Michelson-Morley type of experiments that, to his satisfaction, demonstrated that ether did not exist and that the speed of light was constant, the very two ingredients that, according to his above words, Einstein needed in order shore up his theory. As we noted earlier, however, these were merely Einstein’s assumptions, or should we say, forced answers, to a problem that could have easily been solved by admitting to a stationary Earth. If Earth was motionless in space, there would be no need to eliminate “absolute rest”; no reason to dispense with a universal medium in space that connects all its events (i.e., ether); no reason to shorten lengths or dilate time.⁶⁴⁶

Moreover, in the phenomenon Einstein describes above concerning the magnet and the induction coil, there would be no “relative motion of the observer or the coordinate system,” since with a stationary Earth and its stationary space, nothing is “relative.” All motion and all time, that is, the man falling from his roof as well as the magnet and the induction coil, can be measured in absolute terms with a motionless Earth being the universal and unchanging reference point. The ether surrounding Earth serves as the universal conduit for all these events, and thus there is no mysterious Newtonian “action-at-a-distance,” but a real time-and-space simultaneity that far exceeds Einstein’s limit of the speed of light (which concept we will develop in subsequent chapters).

We also see that Einstein invariably employs the “observer” as the ultimate basis for judging these issues, but never reveals that his

⁶⁴⁵ “Fundamental Ideas and Methods of Relativity Theory, Present in their Development,” Part II, pp. 20-21, translated from the German by Gerald Holton from Einstein’s own handwriting, dated circa 1919, italics are Einstein’s. Stored in the Einstein Archives at the Princeton Institute for Advanced Study, cited on pp. 381-382 of *Thematic Origins of Scientific Thought*.

⁶⁴⁶ Of course, even from a heliocentric perspective, Einstein’s theory had its internal contradictions. Herbert Dingle, certainly no sympathizer to geocentrism, shows this quite well: “However, there was an apparent absurdity that did not escape such notice as was taken of the theory, and that was that its two postulates...seemed to contradict, not some independent fact or idea, but each other. If the velocity of light was finite, and there was no ether with respect to which it had that finite velocity, the only apparent alternative was that each beam of light had that velocity only with respect to its own source, and this the theory denied” (*Science at the Crossroads*, p. 156).

“observer” is a finite creature with very limited abilities and a confined perspective out of which he has to make such crucial judgments. Further, this “observer” has no foundation upon which to test his judgments against the other “observers” he sees observing. The only thing necessary for Relativity is that the observer has truth in his own little world, and light coming into his retina will magically serve him this manufactured state of mind.

The development from Special Relativity to General Relativity was practically inevitable, for Einstein recognized the flaws in the former quite early. As theoretical physicist Lee Smolin writes:

Special relativity was the result of 10 years of intellectual struggle, yet Einstein had convinced himself it was wrong within two years of publishing it. He rejected his own theory, even before most physicists had come to accept it, for reasons that only he cared about... Why? The main reason was that he wanted to extend relativity to include all observers, whereas his special theory postulates only an equivalence among a limited class of observers – those who aren't accelerating.⁶⁴⁷

We see that Einstein's reliance on the “observer” finally showed its limitations – something he did not foresee before he invented his theory. In essence, the failure of Special Relativity drove Einstein to invent General Relativity, the ultimate theory in which the phenomenon of acceleration was supposedly answered. Why is acceleration the lynchpin? Apparently because Einstein believed that in Special Relativity the equivalence principle he treasured so much could be sustained only between a stationary observer and an observer in uniform motion, but not an observer who is accelerating. Special Relativity holds that an observer at rest and an observer in uniform motion will see the light beam moving at the same speed. This equivalence is allowed, says the theory, because the observer in motion will create, by the mere act of moving, a certain space-time path that the light beam will follow towards him. In other words, space and time are adjusted for a moving observer just enough so that he will see the light beam traveling at the same speed as a motionless observer. A motionless observer, of course, will not change the space-time continuum and thus the path of light need not be adjusted for him.

Why, then, was acceleration a problem for Special Relativity? Because the mathematics of Special Relativity did not incorporate the phenomenon of gravity, and since, according to Einstein, gravity and acceleration were phenomenologically equivalent (that is, the observer cannot tell if he is falling in an elevator or accelerating at the same rate in some other place), then Special Relativity did not have an answer for acceleration, and thus it had no way to describe how an accelerated

⁶⁴⁷ Lee Smolin, *Discover Magazine*, September 2004, p. 38.

observer would see a light beam. Would the light beam seem to go slower? Some physicists tried to solve this problem for Einstein by reworking the components of Special Relativity, but Einstein rejected them because they infringed on his cherished principle of “equivalence.” Without “equivalence” there would be an absolute frame of reference (i.e., the “unthinkable” immobile Earth). In order to preserve equivalence, Einstein had to invent a whole new theory – General Relativity. It was “general” because it was more comprehensive. The General Theory added a very important and needed postulate – that gravity would bend light because it would bend the space in which light traveled. This would serve as the answer to the dilemma, as Eddington put it, since the “Newtonian picture of gravitation as a tug is inadequate. You cannot deflect waves by tugging at them, and clearly another representation of the agency which deflects them must be found.”⁶⁴⁸ Hence, if there were “equivalence” between gravity and acceleration, then acceleration would also bend light. This now became Einstein’s answer to what the accelerated observer would see when he watched a light beam. The faster he accelerates, the more the light beam would bend toward him, for his acceleration creates a proportionate curve of the space-time path that the light beam must follow, and thus, he would see the light beam going the same speed as both the observer at rest and the observer in uniform motion. Mathematically, everything seemed to fit. Unfortunately, it was only because of Einstein’s misinterpretation of the interferometer experiments that led him to base everything on the speed of light, and which led him to make time and space variable. As Lee Smolin describes it:

General Relativity is the most radical and challenging of Einstein’s discoveries...The theory goes much deeper: It demands a radical change in how we think of space and time...All previous theories said that space and time have a fixed structure and that it is this structure that gives rise to the properties of things in the world, by giving every object a place and every event a time...General relativity is not about adding to those structures...It rejects the whole idea that space and time are fixed at all. Instead, in general relativity the properties of space and time evolve dynamically, in interaction with everything they contain.⁶⁴⁹

The consequences of this theory are profound. Simple values that we use in common experience no longer hold true in Relativity. For example, even the value of π , which is 3.14 on Earth, will be different on

⁶⁴⁸ Arthur Eddington, *The Nature of the Physical World*, New York, MacMillian Company and Cambridge University Press, 1929, p. 122.

⁶⁴⁹ Lee Smolin, *Discover*, September 2004, p. 39.

Mars and Jupiter, and everywhere else in the universe. Partially quoting from Einstein, Charles Lane Poor explains:

The general result, however, is that “the geometrical properties of space are not independent, but they are determined by matter.”...Since the time of Euclid we have been taught to think that for every circle, wheresoever situated, on the Earth, about the sun, near Venus, or in the vicinity of the North Star, the circumference is 3.141592+ times the radius. Not so in the relativity theory, every gravitational field has its own system of geometry.⁶⁵⁰

Obviously, if everything is relative to its gravitational field, then π is also relative. Using the mathematics of Minkowski’s “space-time” and Reimann’s non-Euclidean geometry, Einstein could hide the anomalies in complicated tensor formulas. As Arthur Eddington described it:

But space-time is a four-dimensional manifold embedded in – well, as many dimensions as it can find new ways to twist about in. Actually a four-dimensional manifold is amazingly ingenious in discovering new kinds of contortion, and its invention is not exhausted until it has been provided with six extra dimensions, making ten dimensions in all. Moreover, twenty distinct measures are required at each point to specify the particular sort and amount of twistiness there. These measures are called coefficients of curvature. Ten of the coefficients stand out more prominently than the other ten. Einstein’s law of gravitation asserts that the ten principal coefficients of curvature are zero in empty space. If there were no curvature, i.e. if all the coefficients were zero, there would be no gravitation. Bodies would move uniformly in straight lines. If curvature were unrestricted, i.e. if all the coefficients had unpredictable values, gravitation would operate arbitrarily and without law. Bodies would move just anyhow. Einstein takes a condition midway between; ten of the coefficients are zero and the other ten are arbitrary. That gives a world containing gravitation limited by a law. The coefficients are naturally separated into two groups of ten, so that there is no difficulty in choosing those which are to vanish.⁶⁵¹

Reading between the lines, as it were, we can see that General Relativity’s explanation of gravity is nothing more than working backwards from what is already known about the measured force of

⁶⁵⁰ *Gravitation versus Relativity*, p. 47.

⁶⁵¹ Arthur Eddington, *The Nature of the Physical World*, New York, MacMillian Company and Cambridge University Press, 1929, p. 120.

gravity, and then spreading out those results over twenty “coefficients of curvature.” As one author put it: “If written out in full instead of in the compact tensor notation, they would fill a huge book with intricate symbols.”⁶⁵² With twenty variables at his disposal (courtesy of Reimann), Einstein is bound to reach a mixture that coincides with what we observe of gravity in nature. The theory is very convenient, since one can work wonders with mathematics from already-known absolutes. But what it gains in convenience it loses in practical reality. As mathematician Morris Kline sees it:

...Reimann’s 1854 paper convinced many mathematicians that a non-Euclidean geometry could be the geometry of physical space and that we could no longer be sure which geometry was true. The mere fact that there can be alternative geometries was in itself a shock. But the greater shock was that one could no longer be sure which geometry was true or whether any one of them was true...Mathematicians were in the position described by Mark Twain: “Man is the religious animal. He’s the only one who’s got the true religion – several of them.”⁶⁵³

So modern man is left with a clear choice. Either π is the same everywhere in the universe, and thus space is space, and time is time, and neither is increased, decreased or modified, or Relativity is correct and everything is up for grabs. In Relativity theory it is as if life were a haunted house of mirrors in which no image stays the same, and the faster one moves the more distorted the images become. Einstein could not live in a universe where time, space and light were all constant, because, by misinterpreting the interferometer experiments and consequently rejecting an immobile Earth he had no universe to accommodate all three as invariables. The only thing absolute for Einstein is his concept of space-time, since, ironically, he dictates that the changes that will occur in that nebulous dimension are absolute. The way out of this dilemma, however, may be something equally repugnant to modern man: he has to admit that Copernicus was wrong. Adopting an immobile Earth will be the only way of keeping π the same everywhere in the universe, for geostatism is the only way to vanquish Einstein’s haunted house of mirrors.

⁶⁵² Banesh Hoffmann, *Albert Einstein, Creator and Rebel*, London, Granada Publishing, 1979, p. 122.

⁶⁵³ Morris Kline, *Mathematics: The Loss of Certainty*, p. 88.

The Failure of General Relativity

Ironically, as Einstein saw the inherent flaws of Special Relativity, he also began to see flaws in General Relativity. The mathematics that seemed so helpful in arriving at two theories that were absent definitive experimental proof was eventually the same math that showed the inherent anomalies of the theories. For all its muscle in purporting to understand gravity, General Relativity broke down completely in instances where gravity was very strong. Not even a mathematical fudge factor could save it. Consequently, General Relativity led to the phenomenon of black holes – the theoretical vortex where gravity was so strong that not even light could escape its clutches; and without light maintaining its constant speed c , Relativity had nothing upon which to hang its hat. Because “space-time” is infinitely “curved” inward in a black hole, all matter within its vicinity, including light photons, is sucked in, eventually leading to the popular but undefined entity called a “singularity,” which, as we take away the cosmetics of language, actually translates into a total contradiction for the theory of Relativity. As physicist Andrei Linde admits:

A second trouble spot [of the Big Bang] is the flatness of space. General Relativity suggests that space may be very curved, with a typical radius on the order of the Planck length, or 10^{-33} centimeter. We see, however, that our universe is just about flat on a scale of 10^{28} centimeters, the radius of the observable part of the universe. This result of our observation differs from theoretical expectations by more than 60 orders of magnitude.⁶⁵⁴

“60 order of magnitude”! It is unusual for modern periodicals to divulge such a gapping hole in the Big Bang universe prophesied by General Relativity. But what is also not being told to the public about “singularities” is that any object approaching the event horizon of a black hole will grow in mass without limit. Consequently, according to the physics of black holes, it is impossible for any mass to enter a black

⁶⁵⁴ Andre Linde, “The Self-Reproducing Inflationary Universe,” *Magnificent Cosmos, Scientific American*, 1998, p. 99. Linde adds another remarkable observation: “A similar discrepancy between theory and observation concerns the size of the universe, a third problem. Cosmological examinations show that our part of the universe contains at least 10^{88} elementary particles. But why is the universe so big? If one takes a universe of a typical initial size given by the Planck length and a typical initial density equal to the Planck density, then, using the standard Big Bang theory, one can calculate how many elementary particles such a universe might encompass. The answer is rather unexpected: the entire universe should only be large enough to accommodate just one elementary particle – or at most 10 of them. It would be unable to house even a single reader of *Scientific American*, who consists of about 10^{29} elementary particles. Obviously, something is wrong with this theory” (*ibid*).

hole. Objects approaching a black hole must slow down and be refused entry, not accelerate and gain mass.

This was the dead end post of modern cosmology. As *Scientific American* put it: “After all, relativity is riddled with holes – black holes...Clearly the theory is incomplete.”⁶⁵⁵ *Time* magazine added that black holes were “mere mathematical figments” which “so far can be shown only as solutions to the complex equations of general relativity – and very troubling solutions at that.”⁶⁵⁶ According to his colleague John Moffat:

Einstein didn't like black holes. The real motivation for “generalizing” his gravity theory was to see if he could find, as he called them, “everywhere regular solutions” that fit the equations.⁶⁵⁷

Thus, it was Einstein's quest to eliminate black holes altogether. In 1939 he published an article in *Annals of Mathematics* arguing that black holes would not be formed by the collapse of a star, but the record shows he was thoroughly unsuccessful. A few months later [Robert Oppenheimer](#) and Hartland Snyder corrected Einstein's math, concluding that black holes do, in fact, exist in Relativity theory. This once again shows how mathematics can be shaped to provide evidence for two diametrically opposed theories.

The battle between Einstein and Oppenheimer is a *Catch-22* situation for Einstein's followers, for if black holes do not exist (and they have never been proven, experimentally, to exist) then there is no ultimate proof for the vexistence of General Relativity (since the theory predicts they must exist); but if black holes do exist, then General Relativity brings us to a dead end in understanding gravity and the universe at large, since in these “singularities” the laws of physics totally break down. In a singularity gravity becomes a repulsive force rather than an attractive force. Thus, a trap has been set for Relativistic physics out of which there is no escape. Perhaps if these physicists would cease creating universes merely out of mathematical preferences and begin depending on verified experimental evidence, they would at least come to some semblance of truth as to how the universe is constructed. As one author put it:

⁶⁵⁵ George Musser, “Was Einstein Right?” *Scientific American*, September 2004, p. 89. Stephen Hawking adds: “Thus, general relativity brings about its own downfall by predicting singularities” (*Black Holes and Baby Universes*, p. 92).

⁶⁵⁶ *Time*, “Those Baffling Black Holes,” September 4, 1978, pp. 56-62.

⁶⁵⁷ Tim Folger, “Einstein's Grand Quest for a Unified Theory,” *Discover*, September 2004, p. 64.

Mathematics should be used to describe the operation of models, not to build them...equations cannot be made to substitute for the concepts which underlie them. And equations are generally blind to limitations of range and physical constraints. They are too general, and simply lack the sort of specificity that true, intuitive understanding demands. Every equation has a domain of applicability – usually the range of the observations and little, if anything, more...If an equation can be extrapolated outside its domain and gives a singularity (basically, a zero divisor), that singularity does not exist in nature; instead, the model needs modification. Up to now this rule has always proved true. But advocates of “black holes” in the universe would have us believe that the equations which predict them can be relied upon far outside the domain of the observations used to derive those equations.⁶⁵⁸

Others go behind the mystique of General Relativity and show that it is merely a repackaging of old ideas in new mathematics. Reginald Cahill writes:

It has been repeatedly claimed that the Hilbert-Einstein General Theory of Relativity has been confirmed many times, but this is untrue. All but one of the so-called tests merely used the geodesic equation which determines the trajectory of a particle or an electromagnetic wave in a given metric, that metric has in all cases been the external Schwarzschild metric, but apparently unknown to most is that this metric is nothing more than the Newtonian ‘inverse square law’ in mathematical disguise, namely, with the metric expressed in terms of the particular velocity vector flow field corresponding to Newton’s inverse square law. So these tests of GR [General Relativity] were confirming, at best, the flow formalism for gravity, together with its geodesic equation, and had nothing to do with the dynamical content of GR.⁶⁵⁹

As we can easily see, reality is far different from Einstein’s pliable world of mathematics. By giving us knowledge of an immobile Earth, the “Good Lord”⁶⁶⁰ shows us not only that heliocentrism, evolution and relativity are wrong, but that, as the celestial bodies

⁶⁵⁸ Tom van Flandern, *Dark Matter, Missing Planets and New Comets*, revised edition, Berkeley, CA: North Atlantic Books, 1993, p. xxi.

⁶⁵⁹ Reginald T. Cahill, *Novel Gravity Probe B Gravitational Wave Detection*, School of Chemistry, Physics and Earth Sciences, Flinders University, Australia, August 21, 2004, p. 4.

⁶⁶⁰ “The Good Lord” was the term Einstein used when he was confronted with the uncertainties of Quantum Mechanics, stating: “the Good Lord did not play dice with the universe” (*Einstein: The Life and Times*, p. 414).

revolve around the Earth, we are to use them to keep track of space and time. That being the case, we know they are accurate.⁶⁶¹ God, of course, also knows the absolute universal time, and gives us clear indications that such precision not only exists, but that this timetable is shared between the divine world and the human world.⁶⁶² The sun, moon and stars were placed in the cosmos as timekeepers (Genesis 1:14-18), and they are so accurate that if one wants to know the beginning day of creation he only needs to count back three twenty-four hour days and he will know the exact time that the Earth was “without form and void” on the First Day of creation. Similarly, by means of the firmament we can understand the existence of absolute space. Space is not “curved,” it is linear, just as we see on Earth.⁶⁶³ Whenever a Relativist says: “space is curved,” this merely begs the question: “Curved in relation to what?” If the Relativist says: “time slows down,” we respond: “Slows down in relation to what?” If he says that he has a “preferred frame of reference” we ask “what frame, and in reference to what?” Every proposition a Relativist utters assumes there is an absolute against which he can measure his proposition. To put it another way, the whole theory of Relativity, ironically, is based on the assumption that something is at rest. Even if he says “the speed of light is my absolute,” we respond: “the speed of light in relation to what?” And if he is someday so bold as to assume he has a “what,” we are still going to ask him “what in relation to what?” and thus require him to prove his “what” over against any other possible “whats.” If he says, “the universe is at rest” then he is once again on our side, since he has already admitted there is no difference between a rotating Earth in a fixed universe as opposed to a fixed Earth in a rotating universe.⁶⁶⁴ God has sprung a trap for modern man, and Relativity is its name.

⁶⁶¹ Genesis 1:14-17; Psalm 104:19 (LXX 103:19); Sirach 43:6.

⁶⁶² “All things are the works of the Lord...and whatever he commands will be done in his time. No one can say, ‘What is this?’ ‘Why is that?’ for in God’s time all things will be sought after” (Sr 39:16-17); “...for he has appointed a time for every matter, and for every work” (Ec 3:17); “But thou hast arranged all things by measure and number and weight” (Ws 11:20); “And he made from one every nation of men to live on all the face of the Earth, having determined allotted periods and the boundaries of their habitation” (Ac 17:26), cf., Gn. 7:10-11; 8:10; 18:14; 21:2; Ex 9:5; 12:40; Lv 25:8; Js 10:10-12; Jb 14:5; Ps 119:90-91; Jr 33:20; Dn 2:21; 8:14; Mt 20:3-6; 24:36; 26:45; 27:45-46; Lk 22:59; Jn 1:48; 4:52-53; 13:1; Ac 1:7; 17:26; Gl 4:4; 1Tm 2:6; Ap 8:1; 9:15; 11:2-3, 11; 12:6; Sr 48:23; Ws 8:8; 33:8.

⁶⁶³ Genesis 1:6-9; 14-17; Psalm 19:1; 150:1; Sirach 43:1, 8.

⁶⁶⁴ Take, for example, Eddington’s explanation of gravity by means of radial curvature. He writes: “The radius of spherical curvature of every three-dimensional section of the world, cut in any direction at any point of empty space, is always the same constant length.” Two pages later Eddington admits: “There is no such thing as absolute length; we can only express the length of one thing in terms of the length of something else.” Yet Eddington fails to explain how he knows the length of the “something else.” (*The*

Conversely, by the record of meticulous genealogies and chronologies in Holy Writ we know from whence our beginnings occurred. Unfortunately, since the world has been deceived into thinking that the Earth is moving, it is forced to resort to all the contortions and hypotheticals in Einstein's foregoing paragraphs to attempt to make sense of everything. God gave mankind a fixed Earth precisely so we would not be forced into such contortions. The immobile Earth gives us the surest foundation from which to measure the rest of the universe. If the Earth is fixed, we can find the position and distance of any point in the universe by triangulation. Even if we were situated in some remote part of the universe and couldn't see the Earth, we could still determine location based on previous triangulations from positions that had seen the Earth. Moreover, once we assume a fixed Earth, we can take the *ad hoc* Lorentz transformations out of all physics equations. If present-day physicists, astrophysicists and astronomers would accept this one crucial premise, they could solve most, if not all, the mysteries they see in the universe. As Scripture testifies boldly:

Tremble before him, all the Earth; he has made the world firm, not to be moved....Through all generations your truth endures; fixed to stand firm like the Earth....But you have disposed all things by measure and number and weight...Indeed, before you the whole universe is as a grain from a balance, or a drop of morning dew come down upon the Earth. But you have mercy on all, because you can do all things; and you overlook the sins of men that they may repent.⁶⁶⁵

Unfortunately, modern man has a distaste not only for divine revelation but for physical absolutes, for they invariably translate into moral and ethical absolutes, and eventually they lead to the one Absolute to whom man refuses to bow.

Nature of the Physical World, New York, MacMillian Company and Cambridge University Press, 1929, pp. 139, 141). In another place he admits: "Our simple solution has been to give up the idea that one of these is right and that the others are spurious imitations, and to accept them *en bloc*; so that distance, magnetic force, acceleration, etc., are relative quantities, comparable with other relative quantities already known to us such as direction or velocity. In the main this leaves the structure of our physical knowledge unaltered; only we must give up certain expectations as to the behaviour of these quantities, and certain tacit assumptions which were based on the belief that they are absolute" (*ibid*, p. 35).

⁶⁶⁵ A scriptural medley taken from 1 Chronicles 16:30; Psalm 119:90; Wisdom 11:20 (NAB).

The Maze of Relativity Theory

The anomalies and contradictions in Relativity are endless. For all Einstein's remarks about dispensing with ether, we find him having to support a similar concept in order to help his General Relativity theory pan out. He writes:

According to the general theory of relativity space is endowed with physical qualities; in this sense, therefore, there exists an ether. According to the general theory of relativity space without ether is unthinkable; for in such space there would not only be no propagation of light, but also no possibility of existence for standards of space and time (measuring rods and clocks), nor therefore any space-time intervals in the physical sense. But this ether may not be thought of as endowed with the quality characteristic of ponderable media, as consisting of parts which may be tracked through time. The idea of motion may not be applied to it.⁶⁶⁶

So Einstein gets to have his cake and eat it, too. As he once used mathematics, he now twists and turns language itself to get to the position that will make his theory work. Knowing that he cannot escape the concerns of Newton, Maxwell and the pre-Michelson-Morley physics establishment, Einstein resigns himself to accepting that some kind of ether exists, and thus it must have enough "physical qualities" so that it can "propagate light" and serve as the "standard...for measuring rods and clocks...and time intervals in the physical sense," but by some as yet unproven premise we are assured by the same course of logic that such a versatile substance is not "ponderable," has no "parts," and has no "time." What an amazing world Einstein created for himself. Of course, avowed Relativists just shirk off such paradoxes by claiming that the rest of us "just don't understand the theory," but it should be quite apparent by now that this excuse has joined the ranks of those viewing the emperor and his new clothes.

In that light, perhaps these words from Einstein will now make more sense: "When I examine myself and my methods of thought I come to the conclusion that the gift of fantasy has meant more to me than my talent for absorbing positive knowledge"⁶⁶⁷ Or perhaps the following will shed even more light:

Nature is the realization of the simplest conceivable mathematical ideas. I am convinced that we can discover, by means of purely mathematical constructions, those concepts

⁶⁶⁶ Albert Einstein, "Geometry and Experience," in *Sidelights on Relativity*, New York, Dover Publications, 1983, p. 30, cited in *De Labore Solis*, p. 65.

⁶⁶⁷ *Einstein: The Life and Times*, p. 118.

and those lawful connections between them which furnish the key to understanding of natural phenomena. Experience may suggest the appropriate mathematical concepts, but they most certainly cannot be deduced from it. Experience remains, of course, the sole criterion of physical utility of a mathematical construction. But the creative principle resides in mathematics. In a certain sense, therefore, I hold it true that pure thought can grasp reality, as the ancients dreamed.⁶⁶⁸

Consequently, from this point onward, everything gets very complicated and confusing in Relativity theory, for it must answer questions about which it simply could not find logical solutions.⁶⁶⁹ As Dingle puts it:

First, the facts show, I think beyond question, that the traditional proud claim of Science that it acknowledges the absolute authority of experience (i.e., observation and experimentation) and reason over all theories, hypotheses, prejudices, expectations or probabilities, however apparently firmly established, can no longer be upheld...instead of enabling the full implications and potentialities of the fact of experience to be realized and amplified, it has been held necessarily to symbolize truths which are in fact sheer impossibilities but are presented to the layman as discoveries which, though they appear to him absurd, are nevertheless true

⁶⁶⁸ *Thematic Origins of Scientific Thought*, p. 252.

⁶⁶⁹ Some of these include the following items, some of which have already been addressed in the main body of this volume: (1) how to determine which clock ticks more slowly, A or B, when both are in uniform relative motion (cf., *Science at the Crossroads*, Herbert Dingle, Western Printing, 1972, p. 81); (2) how a person traveling 99% the speed of light could never get one fraction closer to a light particle traveling ahead of him, and in fact, the light particle would continue to *increase* its distance from the person by 300km/sec (*The Einstein Myth and the Ives Papers*, Part 1, p. 3); (3) the decrease in light's measured speed over the course of 150 years (cf., experiments with quasar light, August 2002, *Nature*, Paul Davies (winner of the 2002 Michael Faraday prize) from Macquarie University, Australia; *Science* 1927; *Nature* 1934 citing M. Gheury de Bray in *L'Astronomie*, which showed by statistics since 1849 that light was slowing down by four kilometers per second every year; (4) experiments in which light reacts faster than c (cf., Lijun Wang at NEC Research Institute, Princeton, where light was made to travel $300 \times c$; (5) xenon experiments showing light's speed being dependent on its source (cf., 1962, *New Scientist* (16:276) citing W. Kantor of the US Navy Electronics Laboratory in the *Journal of the Optical Society of America* (vol. 52, no. 8, p. 978); (6) the ability of photons to correlate their movements even when separated by time and distance (cf., 1982, John Stewart Bell experiment conducted at the Institute of Theoretical and Applied Optics, Paris; (7) how to explain rotation. For example, it is known that signals from a Global Positioning Satellite (GPS) approaching a ground station arrive 50 nanoseconds less than a GPS receding from the ground station, and thus the constancy of the speed of light seems not to hold. The same effect was demonstrated by Georges Sagnac in 1913 and predicted by Albert Michelson (See section on Sagnac in Chapter 6).

because mathematical inventions, which he cannot understand, require them...the theory of relativity is believed to be so abstruse that only a very select body of specialists can be expected to understand it. In fact this is quite false; the theory itself is very simple, but it has been quite unnecessarily enveloped in a cloak of metaphysical obscurity which has really nothing whatever to do with it.⁶⁷⁰

Ironically, Relativity did not have the adherents it sought, at least prior to the famous 1919 eclipse photographs of the bending of starlight near the sun produced by Arthur Eddington, which is a story in itself (see Appendix 4). Prior to 1919, most of the major players in physics either rejected or did not fully embrace Relativity. Ernst Mach rejected it outright. Henri Poincaré never publicly supported Einstein in print. Hendrik Lorentz encouraged Einstein, but never fully embraced Relativity. Walter Ritz, who at first collaborated with Einstein, expressed his doubts about Special Relativity as early as 1909.⁶⁷¹ Max Planck,

⁶⁷⁰ Herbert Dingle, *Science at the Crossroads*, pp. 12-13, 16. Due to his opposition to Einstein, until his death, Dr. Dingle was shunned by the press and was consistently denied publication of his papers in the prestigious periodicals, *Nature* and *Science*. After many appeals, *Nature* finally published Dingle's critique of Einstein (*Nature*, 195, 985 (1962); and 197, 1287 (1963)). As Dingle writes, his efforts "received only one reply from an acknowledged authority, namely, Professor Max Born...". Born did not deny Dingle's critique of Einstein, but only said it was not expressed clearly. Dingle continues: "It is understandable that there should be hesitation in believing that a theory so firmly established, and apparently supported by a great weight of evidence, should be disproved as simply as my letter suggested, but it is equally hard to believe that, if such a simple disproof contained a fallacy, no exposure of that fallacy (which, it may be added, there have been numerous private but unsuccessful attempts to extract from recognized authorities), should have been forthcoming. This criticism of the theory, in various forms, has been published repeatedly, during a period of almost nine years, in physical, astronomical and philosophical journals and in four books, in Britain and in America, without eliciting a single published comment. Reluctance to correct errors in such matters is not a customary feature of scientific discussion, so the natural inference is that there is here no error to correct" (*Science at the Crossroads*, p. 228).

⁶⁷¹ W. Ritz, *Annales de Chimie et de Physique*, vol. 13, 145 (1908). Just prior to Ritz's death, he and Einstein published an account of their controversies concerning their respective relativity theories (W. Ritz and A. Einstein, *Physique Zeitschrift* 10, 323, 1909). Ritz's contentions with Einstein were especially regarding the issues surrounding absolute motion and the emission theory of light. Ritz's hypothesis was supposedly disproved by the Alväger, Nilsson, Kjellman experiment when gamma radiation with spectrum shifts traveled at the same velocity as beams from particles showing no spectrum shift, but as Dingle writes: "But suppose the beams had traveled with different velocities. Then the electromagnetic theory would have been disproved, and so the evidence that the sources were particles moving with the supposed velocities would have disappeared. Such an experiment therefore could not possibly have tested Ritz's hypothesis" (*Science at the Crossroads*, p. 234). See also Walter Kaufmann's 1906 experiment (fn. 52), which is evaluated by Ritz in the above publication *Annales de Chimie*, that helped determine the nature of the electron and thus deny the validity of the Lorentz-Einstein theory, at least until Max Planck helped to revive it. (For an in-depth analysis of the Ritz-Einstein controversy, see John D. Norton's, "Einstein's

although he accepted Special Relativity, rejected General Relativity. Ernest Rutherford called it “nonsense.”⁶⁷² Frederick Soddy said it was an “arrogant swindle,” and “an orgy in amateur-physics.”⁶⁷³ Albert Michelson, who performed one of the very experiments that led to Einstein’s theory, said he was sorry that his work may have had a part in creating such a “monster.”⁶⁷⁴ Finally, as he found himself shifting back and forth in the maze created by Einstein, one day supporting him, the next day entertaining doubts, in one of his more somber moments, Arthur Eddington stated:

For the reader resolved to eschew theory and admit only definite observational facts, all astronomical books are banned. There are no purely observational facts about the heavenly bodies. Astronomical measurements are, without exception, measurements of phenomena occurring in a terrestrial observatory or station; it is only by theory that they are translated into knowledge of a universe outside.⁶⁷⁵

As the saga continues, the problems mount for Einstein. He needs some kind of evidence that gravity bends light (and in the exact amount that Relativity predicts), and he also needs evidence that there is no absolute motion and no ether, otherwise, his “thought” experiments will remain just that – thoughts. This is why the Michelson-Morley experiment becomes extremely important to him, as it does for everyone else in the Relativistic camp, both then and now, for it will be the only “proof” for a long time to come. It is the same reason the Michelson-Morley experiment, and its dozens of repetitions over the years, have attained such popularity in the literature of modern physics. In retrospect, the Michelson-Morley experiment would determine, once and for all, whether Maxwell’s equations were true in the observer’s frame of reference, and thus show whether that particular frame was moving or not. Naturally, if one is moving through a medium, the wave he observes will vary depending upon the direction he is moving.

Investigations of Galilean Covariant Electrodynamics Prior to 1905,” University of Pittsburgh, Dept. of History and Philosophy of Science, rev. Jan. 28, 2004, pp. 12-22).

⁶⁷² Quoted in the *Economist*, provided by Martin Gwynne. Herbert Dingle adds: “Lord Rutherford...could be more accurately described as scornful rather than as critical of the relativity theory” (*Science at the Crossroads*, p. 96).

⁶⁷³ “The Wilder Aspects of Atomic Disintegration,” *New World Publications*, St. Stephens House, Westminster S. W. I, 1954.

⁶⁷⁴ R. S. Shankland, “Conversations with Einstein,” *American Journal of Physics*, 31:56, 1963, cited in *Thematic Origins of Scientific Thought*, pp. 249, 270.

⁶⁷⁵ Quoted in *Cosmology*, by Edward R. Harrison (Cambridge University Press, 1981), p. 226, cited in *De Labore Solis*, p. 44.

However, since the observer is on Earth, a null result to the Michelson-Morley experiment would offer the distinct possibility that the Earth was not moving. Of course, that solution would not be accepted. Science had to search for another solution – one that could save Maxwell, Copernicus and Galileo, and the face of modern science. Arago's, Hoek's and Airy's experiments had already shown that Michelson-Morley should give a null result, but the powers-that-be insisted on checking it again and again because they simply couldn't believe what their eyes were telling them. But since science could not change the results, it chose to believe that the Earth's motion could not be detected in the ether rather than accepting that the Earth was not moving in an ether, and therefore it concluded that Maxwell's equations will work in any inertial frame and are not dependent on ether. Lorentz added the "transformation" equations, which shortened the lengths and the time of objects going through ether. All was well, at least for a while.

Oh, how I love thy law!
It is my meditation all the day.
Thy commandment makes me
wiser than my enemies,
for it is ever with me.
I have more understanding than all my teachers,
for thy testimonies are my meditation.
I understand more than the aged,
for I keep thy precepts.

Psalm 119:97-100 [118:97-100]

Tremble before him, all the earth; yea, the world stands
firm, never to be moved.

1 Chronicles 16:30

"No amount of experimentation can ever prove me right; a single experiment can prove me wrong."

Albert Einstein⁶⁷⁶

"If Michelson-Morley is wrong, then Relativity is wrong."

Albert Einstein⁶⁷⁷

"General Relativity has passed every solar-system test with flying colors. Yet so have alternative theories."

Clifford Will⁶⁷⁸

"Thus, general relativity brings about its own downfall by predicting singularities."

Stephen Hawking⁶⁷⁹

⁶⁷⁶ Attributed.

⁶⁷⁷ Einstein's words to Sir Herbert Samuel on the grounds of Government House, Jerusalem, Israel, cited in *Einstein: The Life and Times*, p. 107.

⁶⁷⁸ Clifford Will, "The Confrontation Between Gravitation Theory and Experiment," *General Relativity: An Einstein Centenary Survey*, ed., Stephen W. Hawking, Cambridge University Press, 1979, p. 62.

⁶⁷⁹ *Black Holes and Baby Universes*, p. 92.

Chapter 6

What Did the Michelson-Morley Experiment Actually Demonstrate?

What is at Stake?

There has been much debate about whether the Michelson-Morley experiment was correctly interpreted. The 1887 experiment found fringe shifts that corresponded to about a 4 km/sec speed of ether against the Earth, but since Michelson and Morley assumed the Earth was already moving at 30 km/sec around the sun, they reasoned that the experiment should have shown enough fringe shifting equating to a speed of at least 30 km/sec. Since the results were a tenth or less of that value, they interpreted them as “null” and concluded there was no appreciable ether movement against the Earth and no impedance of the light beams in their experiment. Please note here that, based on their presupposition of a moving Earth (which had not been proven, only assumed) they confidently made their conclusions. Obviously, if the Earth were not moving, Michelson and Morley’s conclusions would be totally erroneous.

The 4 km/sec shows that at least *something* was present for which they had to give an explanation, for vacuums in space do not give resistances, especially on the order of 4 km/sec.⁶⁸⁰ In addition, since this *something* is moving at a rate much less than 30 km/sec, they must explain how this entity could cause such noticeable effects upon *all* subsequent interferometer experiments if the Earth was not moving through it. It would have been much easier for them if the experiment had registered zero km/sec instead of 4, since the former figure would have easily allowed them to claim that ether did not exist. In fact, Einstein’s whole theory of Relativity is based on the supposition that there is *nothing* in outer space, and thus the theory requires that there be an interferometer result with absolutely no fringe shifting and a corresponding speed of zero km/sec. If the Earth doesn’t move and yet there is any fringe reading above zero, no matter how small, this should immediately nullify Relativity theory.

What we will find in virtually all of the interferometer experiments is this: the experimenters took advantage of the fact that since 4 km/sec was much closer to zero km/sec than it was to 30 km/sec,

⁶⁸⁰ We pause to note that 4 km/sec is a rough average accumulated by the interferometer experiments. This value fluctuates depending on the latitude and altitude of the apparatus, as it should in principle. Apparatus closer to the equator should register higher speeds, whereas those at the poles should register near zero. Similarly, lower altitudes should register slower speeds.

this difference was used to justify eliminating a material ether for their new cosmological concepts. Consequently, each time an interferometer experiment was performed subsequent to 1887, the experimenters would give the same interpretation that Michelson and Morley gave. Nobody paid any attention to, or didn't know what to do with, the single-digit movement of the ether found in all the experiments, since, obviously, they were all convinced that the Earth was moving through space and that its 30 km/sec speed around the sun made the 4 km/sec totally insignificant. Lorentz, for example, attempted to attribute the 4 km/sec to experimental errors, stating: "If we make the necessary correction, we arrive at displacements no greater than might be masked by errors of observation."⁶⁸¹ But here is the reality: if something substantive constitutes space and is causing the consistent single-digit readings, then there is no "error of observation." As Charles Lane Poor stated:

The Michelson-Morley experiment forms the basis of the relativity theory: Einstein calls it decisive...if it should develop that there is a measurable ether-drift, then the entire fabric of the relativity theory would collapse like a house of cards.⁶⁸²

Scientific experiments are all a matter of interpretation and perspective. If the scientist comes to the experiment with various presuppositions and prejudices that are not true, this will turn even the most accurate experiment into an exercise in futility. We have already cited [Arthur Eddington's](#) admission: "There are no purely observational facts about the heavenly bodies...it is only by theory that they are translated into knowledge of a universe outside." The Michelson-Morley experiment brought this truth out better than any other, since its results were so devastating to science. As Clark reveals:

It [Michelson-Morley] suggested, furthermore, that the best path to be followed might not be that of observation followed by the induction of general laws, but the totally different process of postulating a theory and then discovering whether or not the facts fitted it. Thus a theory should start with more scientific and philosophical assumptions than the facts alone warranted. A decade later the method was to provide the startling results of the General Theory.⁶⁸³

Blinded by the unproven premise of heliocentrism, scientists would resort to all kinds of twisted and *ad hoc* explanations of the

⁶⁸¹ "Michelson's Interference Experiment," H. A. Lorentz, cited in *The Principle of Relativity*, 1952, p. 4.

⁶⁸² *Gravitation versus Relativity*, p. 261.

⁶⁸³ *Einstein: The Life and Times*, pp. 126-127.

factual data and make up extravagant new theories as they went along, concocting bizarre concepts that brought common sense, and even personal sanity, to the brink of destruction. It was as if a pandemic disease had spread across the landscape, and hardly any scientist would escape its grip. Science was now working by this simple syllogism:

- Major Premise:** It is self-evident the Earth moves around the sun.
- Minor Premise:** Interferometers cannot measure any such movement.
- Conclusion:** Earth moves, matter shrinks, time dilates, and neither ether nor absolute motion exist. Everything is relative. Case closed.

We see this even among some of Einstein's critics. Max von Laue, who had critiqued the use of $E = mc^2$ by noting that Einstein arbitrarily eliminated kinetic energy, was still sold on the idea of Relativity and, like Einstein, never gave a thought to a fixed-Earth to explain the perplexing results from various experiments. For example, in reference to the Trouton-Noble experiment, which attempted to show that electrically charged plates would assume a position of least resistance caused by the Earth's movement, von Lau writes:

Thus it appeared reasonable that an electrically charged condenser...would assume a particular orientation relative to the velocity of the Earth, the one in which the angular momentum vanishes. This conclusion is inescapable in Newtonian mechanics. However, in 1903 Fr. T. Noble and H. R. Trouton searched for this effect in vain, and even the more accurate repetition of their experiment by R. Tomaschek (1925-26) showed no trace of the effect. Their result is just as convincing a proof of the principle of relativity as Michelson's interference experiment. Both of these experiments proved the necessity for a new mechanics; Michelson's experiment because it showed the contraction of moving bodies in the direction of motion, and the experiment of Trouton and Noble because it showed that an angular momentum does not necessarily lead to a rotation of the body involved....Thus, a new epoch in physics created a new mechanics...it began, we might say, with the question as to what effect the motion of the Earth has on physical processes which take place on the Earth...we can assign to the dividing line between epochs a precise date: It was on September 26, 1905, that Albert Einstein's investigation entitled "On the Electrodynamics of Bodies in Motion" appeared in the *Annalen der Physik*.⁶⁸⁴

⁶⁸⁴ *Albert Einstein: Philosopher-Scientist*, pp. 522-523.

One might think that if the plates showed “no trace of the effect” that a reasonable conclusion would be that there was no angular momentum from a moving Earth against which they had to orient themselves. But having accepted Copernicanism as gospel, von Laue is led to the incredible conclusion that “angular momentum does not necessarily lead to a rotation of the body involved.” Rather than question Copernicanism, von Laue would rather modify one of the most sacrosanct principles of physics, and one that had never heretofore been disproved by anyone – the law of angular momentum. That an intelligent man would not at least save himself and the science of physics a degree of self-respect by perhaps considering that a possible reason Trouton-Noble’s results were negative was that the Earth was motionless, shows quite clearly how presuppositions hold ultimate sway over reasonable conclusions.

Accordingly, when Relativistic scientists consistently saw the 4 km/sec results of virtually all the interferometer experiments, we invariably see the following conclusion written in their textbooks: “These results are consistent with the Special Theory of Relativity.” Thus everyone thinks that the theory has been verified countless times. But the only thing that has been verified is that Relativists continue to think the Earth is moving without any physical proof that it is actually doing so. Moreover, since Special Relativity was invented to compensate for the fact that the interferometer and other experiments were showing that the Earth wasn’t moving (or, either it or the ether was moving at 4 km/sec instead of the required 30+ km/sec), happily, but presumptuously, they concluded that each subsequent experiment which showed a 4 km/sec result (or thereabouts) would invariably be interpreted as “consistent with the Special Theory of Relativity.” In short, this became a vicious circle of self-attestation. The sad fact is that there seems to be no escape from this viciousness, unless, of course, there comes about the same overhaul of physics to the same degree that Special Relativity foisted itself upon the world in 1905. Returning to a motionless Earth in the center of the universe is just such an overhaul. We will examine this more in later chapters. For now, we will trace the history of the interferometer experiments subsequent to the writing of Einstein’s 1905 paper that reported the same “null” results as those done prior to 1905.

Interferometer Experiments Subsequent to 1905

In 1926 Roy Kennedy performed an experiment, placing an interferometer in a pressurized metallic chamber at a high altitude but yielded what he interpreted as “null” results, and in 1932 he wrote a paper with Edward Thorndike on those results.⁶⁸⁵ In 1926 the experiment by A. Piccard and E. Stahel at Mt. Rigni also produced what they understood as a “null” result.⁶⁸⁶ In 1927, K. K. Illingworth improved the

⁶⁸⁵ R. J. Kennedy at the Conference on the Michelson-Morley Experiment held at Mount Wilson Observatory, Feb. 4-5, 1927, in *The Astrophysical Journal* 68, 1928, 367-373; R. J. Kennedy, “A Refinement of the Michelson-Morley experiment,” Proc. National Academy of Science, 12, 621-629, 1926; R. J. Kennedy and E. M. Thorndike, *Experimental Establishment of the Relativity of Time*, *Physical Review* 42, 1932, 400-418. They used an interferometer similar to Michelson’s but with different arm lengths and none at right angles to the others. They also kept the apparatus at 0.001 degree Celsius, as well as using photographs of the fringes for calibration. Kennedy and Thorndike are quite transparent, however, in their bias towards Relativity, stating: “With the apparatus finally employed, we have shown that there is no effect corresponding to absolute time unless the velocity of the solar system in space is no more than about half that of the Earth in its orbit. Using this null result and that of the Michelson-Morley experiment we derive the Lorentz-Einstein transformations, which are tantamount to the relativity principle....there can be little doubt that the experiment yields a strictly null result.” Perhaps Kennedy’s choice of language, “there can be little doubt” betrays the fact to the keen observer that, unless their result was zero, then at least a “little doubt” exists as to whether there, was, in fact, a completely null result. In actuality, Kennedy and Thorndike did not find a “null” result, but one which showed a resistance (i.e., the ether moving against the Earth) at “ 10 ± 10 km per sec,” which in terms of these kinds of experiments, is not “scarce” at all. So how did they justify interpreting this as a “null” result? They did so by comparing their results against the hypothesized speed of receding nebulae: “In view of relative velocities amounting to thousands of kilometers per second known to exist among the nebulae, this can scarcely be regarded as other than a clear null result; it is of the same order of precision as that of the Michelson-Morley experiment.” Múnera adds: “since Kennedy was looking for shifts produced by 90° rotations from a reference position, equation $D_A = 2A \cos 2\omega_N$ tells that, if RA points north, the expected shift tends to zero when $\cos 2\omega_N \approx 0$, i.e., when ω_N is close to being a multiple of 45°. For September 16 at Pasadena this occurs four times during the day, around 02:30, 08:50, 17:05 and 18:30 local apparent time....Kennedy says that ‘the experiment was performed....at various times of day, but oftenest at the time when Miller’s conclusions require the greatest effect’ which for ‘the middle two weeks of September, when the present work was done corresponds to local solar times varying from 6:30 A.M. to 5:30 A.M.’ (Kennedy, p. 628). This time period seems to be midway between 02:30 and 08:50, but Kennedy does not explicitly state the *initial* orientation of his interferometer, so that we cannot draw any definite conclusions” (Héctor Múnera, “Michelson-Morley Experiments Revisited: Systematic Errors, Consistency Among Difference Experiments, and Compatibility with Absolute Space,” *Apeiron*, Vol. 5, Nr. 1-2, January-April 1998, p. 46).

⁶⁸⁶ Lynch writes: “...a series of experiments of Professor Piccard of Brussels which at first failed to show, even at the summit of the Rigi, at over six thousand feet of altitude, an ether wind of more than one and a half kilometers a second. Experiments by balloon gave a very different result, the ether wind at eight thousand feet being nine kilometers a second” (*The Case Against Einstein*, p. 45). Galaev reports that the results were 7

sensitivity of Kennedy's device but still produced a "null" result.⁶⁸⁷ Although not an interferometer experiment, nevertheless, in 1927, Pieter

km/sec and that the team concluded that "We cannot discuss Miller's result on the basis of this experimental series, as our measurement's accuracy is just on the border of Miller's observations" ("Ethereal Wind in Experience of Millimetric Radiowave Propagation," *The Institute of Radiophysics and Electronics of NSA in Ukraine*, Aug. 26, 2001, p. 213). Galaev's observation will become more meaningful when we address Miller's results. Analyzing Piccard's data, Múnera writes: "From 96 turns of an interferometer in a balloon over Belgium they obtained a speed of 6.9 km/s with a probable error of 7 km/s. According to conventional statistical practice, the result simply means that at 50% confidence level the true speed is in the interval from 0 to 13.9 km/s. Moreover, there is no reason to believe that one particular value (say, 0 km/s, or 13 km/s) is more likely than another. Then, Piccard and Stahel result is completely consistent with those of Miller....They repeated the experiment in Brussels. Their results are (translating from the French) '60 turns of the apparatus produced an average displacement of 0.0002 ± 0.0007 fringes, which are incompatible with Miller's results.' Not so. Using equations $V = V_0 \sqrt{(|D|/D_R)} = C \sqrt{|D|}$ and $V_0 = V_1$ for $D = D_0$ for their equipment, we get 1.7 ± 3.1 km/s. Assuming that 3.1 km/s was a probable error (as in the balloon experiment), a one-tailed test says that [the] true speed was lower than 9.3 km/s at 95% C.L. Again, compatible with Miller's results. Brylinski long ago criticized the interpretation of Piccard and Stahel on similar grounds (E. Brylinski, "Sur la vitesse relative de la terre et de éther avoisinant," *Comptes Rendus* 184, 1927, 192-193). They unconvincingly replied thus (our translation): 'all our measurements have given ether winds lower than the probable error of our measures, so that we cannot conclude in favor of Miller, as Brylinski does' (A. Piccard and E. Stahel, "Sur le vent d éther," *Comptes Rendus*, 184, 1927, 451-452....Piccard and Stahel repeated the experiment at Mt. Rigi in Switzerland. From 120 turns of the interferometer they found (translating from French): 'a sinusoidal curve whose amplitude is 40 times smaller than the curve that Miller would have predicted, all these within the limits of our probable errors....this curve corresponds to an ether wind of 1.45 km/s' ("L absence du vent d éther au Rigi," *Comptes Rendus*, 185, 1927, 1198-1200). Again, note [third systematic error]. Also, this is not a zero speed. Unfortunately, they did not report the probable error" (Héctor Múnera, "Michelson-Morley Experiments Revisited: Systematic Errors, Consistency Among Difference Experiments, and Compatibility with Absolute Space," *Apeiron*, Vol. 5, Nr. 1-2, January-April 1998, p. 45).

⁶⁸⁷ K. K. Illingworth, "A repetition of the Michelson-Morley experiment using Kennedy's refinement," *Physical Review*, 30, 692-696, 1926. Múnera writes: "...most papers exhibit an inconsistency between observation (a non-zero velocity) and interpretation (a null result). This paper is no exception....As usual in other papers, a high experimental resolution is suggested by quoting small fringe-shifts. However, Illingworth's Table I immediately tells us that the quoted sensitivity (1/1500 to 1/500 fringe-shift) is not that good: 3 to 5 km/s. This velocity resolution is from 10% to 17% of the velocity to be measured! (Not an excellent resolution as suggested by the experimenters)....As noted...for the Piccard and Stahel case, the standard interpretation of statistical errors is that the true ether velocity is within the error bounds at some specified C.L. For instance for session 1A at 11 a.m., the average velocity is 2.12 km/s, the true velocity being between 0.89 and 3.35 km/s at 50% C.L. Of course, for higher confidences the uncertainty band is wider. Similarly for the other seven sessions. Clearly, Illingworth's results were not null. However, Illingworth was not very certain as to what the interpretation should be, as exemplified by the following rather obscure paragraph from his conclusions: 'Since in over one half the cases the observed shift is less than the probable error the present work cannot be interpreted as indicating an ether drift to an accuracy of one kilometer per second' (page 696)" (Héctor Múnera,

Zeeman's work with the speed of light in different materials showed similar null results.⁶⁸⁸ In 1926-1929, Albert Michelson teamed up with F. G. Pease and F. Pearson and declared again that he produced a "null" result.⁶⁸⁹ In 1930, Von Georg Joos conducted the final *optical* interferometer test and reported that he found the same "null" result.⁶⁹⁰

"Michelson-Morley Experiments Revisited: Systematic Errors, Consistency Among Difference Experiments, and Compatibility with Absolute Space," *Apeiron*, Vol. 5, Nr. 1-2, January-April 1998, pp. 46-47).

⁶⁸⁸ Jozef Wilczynski writes regarding Zeeman's experiments: "They are proper ones to find or test the speed V of the Earth's surface with respect to an ether. The results deny the existence of such a speed" (*Toth-Maatian Review*, November 1994, as cited in *The Biblical Astronomer*, Vol. 4, No. 67, 1994). Moreover, Zeeman's experiments are 'first order' in that they are designed to measure the Earth's speed divided by the speed of light, that is v/c , as opposed to 'second order' experiments which measure v^2/c^2 . Zeeman's experiment appears in *Arkhs. Nederl. Sci.* 10, pp. 131-220. See also "Zeeman Effect in Astrophysical Spectra," *Observatory*, No. 850, 69, June 1949, p. 110; "Solar Flares and Zeeman Effect," *Nature*, 164, August 1949, p. 280.

⁶⁸⁹ A. A. Michelson, F. G. Pease and F. Pearson, "Repetition of the Michelson-Morley experiment," *Nature* 123, 1929, 88. Also printed in *Journal of the American Optical Society* 18, 1929, 181-182. Múnera responds: "They reported their findings in a sketchy paper with no error bounds, concluding that: 'The results gave no displacement as great as one-fifteenth of that to be expected on the supposition of an effect due to a motion of the solar system of three hundred km/s' (paper in *Nature*). Since they report a relative displacement, the corresponding solar velocity is then $300(1/15)^{1/2} = 77.5$ km/s, which is not null by any means. In the JOSA paper, they say that the relative displacement was one-fiftieth (= 1/50, a misprint??), leading to a solar velocity of 42.4 km/s. Again, a clearly non-null speed" (Héctor Múnera, "Michelson-Morley Experiments Revisited: Systematic Errors, Consistency Among Difference Experiments, and Compatibility with Absolute Space," *Apeiron*, Vol. 5, Nr. 1-2, January-April 1998, p. 48).

⁶⁹⁰ G. Joos, "Die Jenaer Wiederholung des Michelsonversuchs," *Annalen der Physik S.* 5, vol. 7, No. 4 (1930), 385-407. Joos used a quartz-based optical interferometer placed in a vacuum-metallic chamber with photographic detectors. He found that the "required" ethereal wind did not exceed a value of 1 km/sec. One reason Joos' results may have been low, as posited by V. A. Atsukovsky, is that the electrons in Joos' metal covering created a Fermi surface and thus partially shielded the apparatus from the ether's movement. He writes: "It is the same as making the attempt to measure the wind, which blows outdoors, looking at the anemometer in a closed room" (Yuri Galaev, "Ethereal Wind in Experience of Millimetric Radiowave Propagation," *The Institute of Radiophysics and Electronics of NSA in Ukraine*, Aug. 26, 2001, p. 212, translation improved). Galaev concludes: "The known works...cannot be ranked as experiments which could confirm or deny Miller's results [or] confirm or deny the hypothesis about the ether's existence in nature." Múnera adds: "...Joos' curves for individual measurements do not need to have the same amplitude and shape. Indeed, Joos observed such differences (see his figure 11, page 404). Unfortunately, Joos did not expect such variations (again, another instance of systematic error #2), so that he rejected all large amplitudes as due to experimental errors (he particularly mentions session 11 at 23:58). From smaller amplitudes, Joos obviously obtained a small velocity that he reported (translating from German) as 'an ether wind smaller than 1.5 km/s' (page 407). Even then, this is not a zero velocity" (Héctor Múnera, "Michelson-Morley Experiments Revisited: Systematic Errors, Consistency Among Difference

After Joos, those interested in testing the “null” results switched to resonators, lasers, masers and other such sophisticated equipment.

In 1960 the team of Charles Townes and John Cedarholm tested the frequencies of microwaves emitted from two ammonia masers discharged in opposite directions, interchanging their positions every 24 hours. They reported a “null” result. In 1964, a team headed by T. S. Jaseja did a revision of Michelson-Morley’s using lasers as the two sources of light, providing sharper lines to the fringe shifts. The results were again interpreted as “null.”⁶⁹¹ In 1969 Jacob Shamir and R. Fox did an experiment similar to Michelson-Morley using a laser-based optical system with a sensitivity of determining fringes to within 0.00003 of a

Experiments, and Compatibility with Absolute Space,” *Apeiron*, Vol. 5, Nr. 1-2, January-April 1998, pp. 48-49).

Robert Shankland categorized the experiments from Michelson to Joos in a 1955 article. He separates them into “Fringe Shift Expected” (FSE) and “Fringe Shift Measured” (FSM). The results he records are as follows: 1881 Michelson: FSE: 0.04, FSM: 0.02 [r = 50%]; 1887 Michelson-Morley: FSE: 0.4, FSM: <0.01 [r = 2.5%]; 1902-04 Morley-Miller: FSE: 1.13, FSM: 0.015 [r = 1.3%]; 1921 Miller: FSE: 1.12, FSM: 0.08 [r = 7.1%]; 1923-1924 Miller: FSE: 1.12, FSM: 0.03 [r = 2.6%]; 1924 Miller (sunlight): FSE: 1.12, FSM: 0.014 [r = 1.2%]; 1924 Tomascheck (starlight): FSE: 0.3, FSM: 0.02 [r = 6.62%]; 1925-26 Miller: FSE: 1.12, FSM: 0.088 [r = 7.8%]; 1926 Kennedy: FSE: 0.07, FSM: 0.002 [r = 2.8%]; 1927 Illingworth: FSE: 0.07, FSM: 0.0002 [r = 0.28%]; 1927 Piccard and Stahel: FSE: 0.13, FSM: 0.006 [r = 4.6%]; 1929 Michelson: FSE: 0.9, FSM: 0.01 [r = 1.1%]; 1930 Joos: FSE: 0.75, FSM: 0.002 [r = 0.26%] (R. S. Shankland, et al., *Review of Modern Physics* 27:2, 167-178 (1955), my ratios supplied in brackets. Except for Illingworth and Joos, whose results may be accounted for by Atsukovsky’s explanation; and Michelson’s 1881 effort which Lorentz discounted, all the other experiments show a ratio of FSE:FSM ranging from 1.1% to 7.8%, which means that all the experiments were basically seeing the same thing – a slight ether drift within the same parameters. Interestingly enough, the 1887 Michelson-Morley has a FSE:FSM ratio of 2.5%, and here Shankland inserts “8 km/sec” as the “Upper Limit on Velocity of Ether.” Although he shows no other “Upper Limit” values except for Illingworth at “1 km/sec,” we would assume that the higher the ratio the higher the ether velocity. Proportionately, then, Miller’s 1925 ratio of 7.8% would correspond to his findings of “10 km/sec.”

⁶⁹¹ T. S. Jaseja, A. Javan, J. Murray and C. H. Townes, “Test of Special Relativity or of the Isotropy of Space by use of Infrared Masers,” *Physical Review* 1, 133a: 1221-1225, 1964. The team used two Helium-Neon microwave masers mounted perpendicularly on a rotating table and recorded the periodic frequency between the two. They found that the frequency shift between the two masers was 275 cycles/second, and they put an upper limit on the anisotropy of space at 30 m/sec. Prior to this C. H. Townes did a maser oscillator experiment in 1958, with similar results (*Physical Review Letters* 1, 352, 1958). See also Alan Kostelecký, “The Search for Relativity Violations.” Speaking of the same helium-neon masers, he writes: “Exceptional sensitivity to relativity violations has also been achieved in clock-comparison experiments....These experiments have attained the remarkable sensitivity of 10⁻³¹....Various clock-comparison experiments with atoms as clocks have been performed at other institutions, achieving sensitivities of 10⁻²⁷ to 10⁻²³ for different types of relativity violations involving protons, neutrons and electrons” (*Scientific American*, Sept. 2004, p. 100).

fringe width. They report a “null” result but with an upper limit to the ether’s velocity against Earth of 6.64 km/s,⁶⁹² (which, again, is very close to the 4 km/sec found by Michelson and Morley). In 1970, R. Latham and J. Last performed a similar set of experiments and claimed to have produced a “null” result.⁶⁹³ In 1979, Alain Brillet and J. L. Hall repeated Jaseja’s experiment with even more precision and reported that they also found “null” results.⁶⁹⁴ Of course, although all of these experiments found the same “null” results, no one was giving consideration to the fact that a perfectly viable interpretation was that the Earth was standing still against a slow moving ether. Due to the popularity of Einstein’s Relativity theory, all the interpretations sought to maintain a moving Earth without ether.

⁶⁹² J. Shamir and R. Fox, *Il Nuovo Cimento* 62B, No. 2, 1969, p. 258.

⁶⁹³ R. Latham and J. Last, *Proceedings of the Royal Society of London*, A320, 131, 1970.

⁶⁹⁴ Brillet and Hall report: “Rotation of the entire electro-optical system maps any cosmic directional anisotropy of space into a corresponding frequency variation. We found a fractional length change $\Delta l / l = (1.5 \pm 2.5) \times 10^{-15}$, with the expected $P_2(\cos \theta)$ signature. This null result represents a 4000-fold improvement on the best previous measurement of Jaseja *et al.*” (*Physical Review Letters* 42, 549-552, 1979. H. C. Hayden disputes these null results, saying they originate from the way data has been interpreted (Hayden, *Galilean Electrodynamics* 1, 1990, pp. 10-71). Accordingly, Brillet and Hall also reported a frequency shift of 17 Hz, which was double the rotation rate of the interferometer table, but which they could not explain and left it as an “unknown.” Later, others interpreted the 17Hz result as due to “the rotation of the Earth” (Aspden, *Physical Letters* 8, No. 9, 1981, p. 411). This “interpretation,” of course, begs the question, since a rotating Earth has not been proven, subsequently leaving ether, in slight movement against Earth, to answer the discrepancy. Their difficulty, interestingly enough, leads right to the “ether entrainment” theory, that is, that a dynamic ether exists but remains with Earth, since Earth is imbedded in it. This leaves room for an explanation of the 1913 Sagnac interferometer experiment, which we will address later. In light of Brillet and Hall’s results, some scientists have begun to speak of “quantum ether.” In 1990 Hils and Hall did a similar experiment but with lasers mounted to the Earth for greater stability, and found the same results as Brillet and Hall (*Physical Review Letters* 64 (1990), p. 1697). In any case, Galaev reports that the reason those after Joos kept seeing a “null” result was due to the use of metal chambers. Since most of the experiments used gamma radiation as the light source, the experimenters covered their apparatus with metal to protect themselves from harm. Dayton Miller, whom we will address later, warned of using metal chambers for this very reason (Yuri Galaev, “Ethereal Wind in Experience of Millimetric Radiowave Propagation,” *The Institute of Radiophysics and Electronics of NSA in Ukraine*, Aug. 26, 2001, p. 212).

What Does This Mean for Geocentrism?

Before we analyze those results, let us address the important question of what a positive result to the interferometer experiments means for both the theory of Relativity and the concept of a stationary Earth. On the one hand, a positive result would completely destroy Einstein's theory of Relativity, since it would show that: (1) ether exists, and (2) either the ether or the Earth serves as the absolute reference frame by which all motion can be measured. As Einstein himself said: "If Michelson-Morley is wrong, then relativity is wrong."⁶⁹⁵ It would mean that science has no rebuttal to the very experiment designed to show that the Earth was moving. It would mean that most, if not all, current physics would literally have to go back to the drawing board and begin again. But since modern science has put so much stock in Relativity, it has, to put it mildly, a vested interest in preferring a "null" result to the interferometer experiments. At the same time, however, each verification of a "null" result leaves open an equally viable interpretation, that is, the Earth is not moving. Obviously, then, with regard to "null" results from an interferometer, modern science is in a *Catch-22* situation.

On the other hand, a positive result could mean one of two things regarding the Earth. It could mean either that the Earth was traveling through the ether, or it could mean that Earth was stationary, and the ether was slowly moving against it. To support Copernicanism, modern physics could opt for the former, but this choice would automatically negate Relativity theory – a cherished commodity that few, if any, were willing to give up. A negative or null result, as we have seen, meant that physics had to find a reason why the speed of light was not impeded as it traveled in the direction of the Earth's apparent motion through the ether. Lorentz and Fitzgerald tried to solve this problem by saying that the apparatus measuring the speed of light contracted and thus wasn't able to measure any difference in speed. Einstein's solution was to dispense with the ether and say that there was no difference in light's speed due to time contraction. But neither Lorentz nor Einstein ever had to face *positive* results from an interferometer, or, as the history of interferometer experiments show, they made a concerted effort to deny or trivialize any positive results. If the result turned out to be positive, it would have made a laughing stock of the hypothetical contortions into which science allowed itself to fall when they thought the results were negative (e.g., contracting matter, time dilation, twins aging at different rates, etc).

⁶⁹⁵ Stated to Sir Herbert Samuel on the grounds of Government House, Jerusalem (*Einstein: The Life and Times*, p. 207).

What About the Copernican Non-Relativists?

From another angle, perhaps we should not be so hard on the Relativists, for the non-Relativists also believe that the Earth moves even though they accentuate the positive results of the interferometer experiments against the Relativist's wish for negative results. It comes down to this: on the one hand, the non-Relativists are correct in their critiques of the illogical nature and absurd results of Relativity theory, but they have little in the way of proving their own position, since they cannot find irrefutable evidence for the elusive ether (that is, they only see effects, not substance) – an absence that has plagued their case since the time of Newton, Fresnel and Maxwell. Having no proof of ether, and having no immobile Earth, the non-Relativists are in almost as much of a dilemma as the Relativists, since wishing for absolutes is not nearly the same as possessing them. Notice how one non-relativist expresses this “wish”:

The relativists talk about accelerative (inertial) forces applying to some body when that body speeds up relative to some highly tangible reference, namely, all the mass in the universe [as did Einstein and Ernst Mach]. All that is necessary to convert this reference frame is to identify some representative central position for all mass, with respect to which inertial forces in accelerating bodies actually occur. Our knowledge of the universe does not at present permit one to say precisely how to define this representative central position. But one possibility that presents itself is that of the centroid of the universe (center of mass), the point at which the universe would balance if the universe could somehow be weighed. But the precise definition of this representative central position of all matter is not needed in order to suppose that it exists as physically relevant, as the reference point with respect to which all accelerations occur.⁶⁹⁶

Suffice it to say that, geocentrism holds to what precisely Turner envisions to solve the “Relativity” problem, only it is Earth that is the “centroid of the universe (center of mass), the point at which the universe could balance if...weighed.” That's why Earth doesn't move. As we noted earlier, contrary to popular opinion, Newton's laws of motion do not hold that the smaller body will necessarily revolve around the larger body; rather, both bodies will revolve around the “center of mass.” If there are more than two bodies involved, then all the bodies, even if there are trillions of them, will all revolve, in some way, around the center of mass.⁶⁹⁷ Hence, if we could “weigh” all the bodies of the

⁶⁹⁶ Dean Turner in *The Einstein Myth*, Part 1, p. 39.

⁶⁹⁷ Newton's Corollary IV under Laws of Motion, Law III, states: “The common center of gravity of two or more bodies does not alter its state of motion or rest by the actions of the bodies among themselves: and therefore the common center of gravity of all

universe, they would have one center of mass. It is no stretch of logic to say that the center of mass would be in the approximate center of all the masses; and thus, there is one central point in the universe upon which all the bodies of the universe revolve. That being the case, there is absolutely no reason why that central point cannot have Earth as its base.

Another such admission by a well-known, non-relativist, Arthur Lynch, is worth noting:

Descartes is, however, doubly interesting to us in the discussion of Relativity, for at one time when the Inquisition was becoming uneasy about his scientific researches, he gave them a reply that satisfied them, or perhaps he merely gained time, which was long, while they were trying to understand its meaning. He declared that the sun went around the Earth, and that when he said that the Earth revolved around the sun that was merely another manner of expressing the same occurrence. I met with this saying first from Henri Poincaré, and I thought then that it was a witty, epigrammatic way of compelling thought to the question; but on reflexion I saw that it was a statement of actual fact. The movements of the two bodies are relative one to the other, and it is a matter of choice as to which we take as our place of observation.⁶⁹⁸

bodies acting upon each other (excluding outward actions and impediments) is either at rest, or moves uniformly in a right line.”

⁶⁹⁸ Arthur Lynch, *The Case Against Einstein*, p. 22.

Correctly Interpreting the Interferometers

Let us return to the war of the interferometers. Once again, what is significant about the results in the foregoing interferometer experiments is that each of them actually showed a small positive result, but because the result did not match expectations for what was assumed to be the only result if the Earth were moving through ether, each experimenter declared his results “null.” For example, Michelson and Morley write about their small positive results as follows:

On the Relative Motion of the Earth and the Luminiferous Ether: The actual displacement was certainly less than the twentieth part of this...It appears, from all that precedes, reasonably certain that if there be any relative motion between the Earth and the luminiferous ether, it must be small; quite small enough entirely to refute Fresnel's explanation of aberration, and that the velocity of the Earth with respect to the ether is probably less than one-sixth the Earth's orbital velocity, and certainly less than one-fourth.⁶⁹⁹

What, precisely, do all these figures mean in regard to the heliocentric/geocentric debate? In the heliocentric theory, the Earth is moving through the ether with both a diurnal and translational movement, that is, it spins on its axis at about 1054 mph (0.45 km/sec) and orbits the sun at about 66,000 mph (30 km/sec), which means that the Earth's rotation speed is 1.6% of its revolution speed.⁷⁰⁰ Clearly, then, the bulk of the ether resistance against the Earth will come from the translational movement as opposed to the diurnal rotation. But if we subtract the translational movement, the remaining resistance will come only from the diurnal movement. This situation is identical to what would occur in the geocentric model, since in the geocentric system there is no translational movement of the Earth against the ether, yet there is a diurnal movement. In other words, the universe's ether is rotating around a fixed Earth at the same rate that the Earth in the heliocentric system would be rotating against the fixed ether, that is, on a 24-hour period. Accordingly, in the geocentric system only the diurnal movement of the Earth against the ether will show up as fringe shifts in the interferometer experiments, and thus we would expect a measurement of shifts much less than the fringe shifts corresponding to the translational movement of 30 km/sec. All things being equal, we would expect the diurnal

⁶⁹⁹ “On the Relative Motion of the Earth and the Luminiferous Ether,” Art. xxxvi, *The American Journal of Science*, editors James D and Edward S. Dana, No. 203, vol. xxxiv, November 1887, p. 341.

⁷⁰⁰ However, in terms of acceleration, where $a = v^2/r$, the translation is only 5% of the rotation.

movement to produce fringe-shifting corresponding to a mere fraction of the fringe-shifting expected for 30 km/sec.

This is precisely what we find in the description given above by Michelson and Morley (albeit, they did not attribute it to a non-translating Earth). They tell us that: “The actual displacement was certainly less than the twentieth part of this.”⁷⁰¹ A “twentieth part” of the fringe shifting corresponding to 30 km/sec brings us to fringe shifting corresponding to at least 1.5 km/sec. After they run this figure through their calculations, Michelson and Morley then tell us: “the velocity of the Earth with respect to the ether is probably less than one-sixth the Earth’s orbital velocity, and certainly less than one-fourth.” One sixth of 30 km/sec is 4.8 km/sec, which agrees precisely with the average of 4.0 km/sec in the majority of the interferometer experiments. In brief, the geocentric model has a simple explanation for the unexpected results of the Michelson-Morley experiment: the Earth is fixed and the universe and its ether rotate around it.

Perhaps just as important concerning the Michelson-Morley experiment was, even with this small evidence of ether movement, the two scientists concluded that Fresnel’s “explanation of aberration” was “refuted” by their 1887 interferometer experiment. We will recall that Fresnel explained Arago’s stellar aberration results by postulating that it was caused by glass mediums “dragging” ether against an *immobile* ether that surrounded the glass. Interestingly enough, Michelson and Morley had previously stated in 1886 that, after the repeat of Fizeau’s experiment in 1884, they had, at that time, confirmed Fresnel’s formula stating: “the result of this work is therefore that the result announced by Fizeau is essentially correct: and that *the luminiferous ether is entirely unaffected by the motion of the matter which it permeates.*”⁷⁰² So we have Michelson and Morley giving us two different stories, but the one to which they adhere is the 1887 judgment showing that science had no answer to Arago’s experiment and that the Earth’s 30 km/sec clip through space was coming to a screeching halt unless somebody could come up with an explanation.

Still, since the measured ether movement came nowhere near the expected 30 km/sec, the science community invariably considered the Michelson-Morley results as “null.” There were a few voices, however, that did not consider the results trivial. As early as 1902, W. M. Hicks, made a thorough criticism of the experiment and concluded that instead of giving a null result, the numerical data published in Michelson-Morley’s paper shows distinct evidence of an expected effect (i.e., ether

⁷⁰¹ “On the Relative Motion of the Earth and the Luminiferous Ether,” Art. xxxvi, *The American Journal of Science*, eds. James D and Edward S. Dana, No. 203, vol. xxxiv, November 1887, p. 341.

⁷⁰² “Influence of Motion of the Medium on the Velocity of Light,” *American Journal of Science*, 31:386-377, 1886, emphasis in the original.

drift). Unfortunately, the science community has completely ignored Hicks' paper.⁷⁰³

⁷⁰³ Hicks writes: "...the adjustment of the mirrors can easily change from one type to the other on consecutive days. It follows that averaging the results of different days in the usual manner is not allowable unless the types are all the same. If this is not attended to, the average displacement may be expected to come out zero – at least if a large number are averaged" (W. M. Hicks, "On the Michelson-Morley Experiment Relating to the Drift of the Ether," *Philosophical Magazine*, Series 6, vol. 3, 1902, p. 34, see also pp. 9-42. Hicks is cited in Héctor A. Múnera's "An Absolute Space Interpretation of the Non-Null Results of Michelson-Morley and Similar Experiments" in *Apeiron*, Vol. 4, No. 2-3, April-July 1997, who, in turn, cites E. T. Whittaker's two volume work *A History of the Theories of Ether and Electricity* (1887), which mentions Hicks' work, minus the negative conclusion of Michelson-Morley. A year later, Múnera wrote "Michelson-Morley Experiments Revisited: Systematic Errors, Consistency Among Difference Experiments, and Compatibility with Absolute Space." He states: "Despite the null interpretation of their experiment...it is quantitatively shown that the outcomes of the original experiment, and all subsequent repetitions, never were null. Additionally, due to an incorrect inter-session averaging, the non-null results are even larger than reported" (*Apeiron*, Vol. 5, Nr. 1-2, January-April 1998, p. 37). Summarizing the findings, M. Consoli and E. Costanzo write: "The Michelson-Morley experiment was designed to detect the relative motion of the Earth...by measuring the shifts of the fringes in an optical interferometer. These shifts...were found to be much smaller than expected...However...the fringe shifts observed by Michelson and Morley, while certainly smaller than the classical prediction corresponding to the orbital velocity of the Earth, were *not* negligibly small. This point was clearly expressed by Hicks: '...the numerical data published in the Michelson-Morley paper, instead of giving a null result, show a distinct evidence of an effect of the kind to be expected' and also by Miller. In the latter case, Miller's refined analysis of the half-period, second-harmonic effect observed in the original experiment, and in the subsequent ones by Morley and Miller [1905], showed that all data were consistent with an effective, observable velocity lying in the range of 7-10 km/s. For comparison, the Michelson-Morley experiment gave a value $v_{\text{obs}} \sim 8.8$ km/s for the noon observations and a value $v_{\text{obs}} \sim 8.0$ km/s for the evening observations" ("The Motion of the Solar System and the Michelson-Morley Experiment," Istituto Nazionale di Fisica Nucleare, Sezione di Catania Dipartimento di Fisica e Astronomia dell' Università di Catania, November 26, 2003, p. 1). The authors add: "Our findings completely confirm Miller's indication of an observable velocity $v_{\text{obs}} \sim 8.4$ km/s in their data."

The Georges Sagnac Interferometer Experiment of 1913 The Rediscovery of Absolute Motion

No interferometer results have been more puzzling to Relativists, and by the same proportion more ignored, than the 1913 experiment performed by the French physicist, Georges Sagnac (pronounced: Sanyak). Sagnac was a professor of theoretical physics at the University of Paris. Among his previous contributions are the assisting of Pierre Curie in determining the properties of radium, as well as the discovery of secondary X-rays and various other optical effects. His interferometer results have been repeated several times, so it is rather curious why the science establishment has been so averse to publicizing Sagnac's work the same way they advertise Einstein's.⁷⁰⁴ Interestingly enough, Sagnac employed the same principle as the Michelson-Morley experiment.⁷⁰⁵ As Sagnac himself describes it, his is the typical [interferometer](#) methodology:

I cause to revolve uniformly, at one or two revolutions per second, around a vertical axis, a horizontal platform (50 centimeters in diameter) carrying, solidly screwed down, the various pieces of an interferometer similar to that which I have used in my previous researches and described in 1910. The two interfering beams, reflected by four mirrors placed at the edge of the revolving platform, are superimposed in opposite

⁷⁰⁴ Notable exceptions are E. J. Post in *Reviews of Modern Physics* 39, 1967, pp. 475-493; Herbert Goldstein, *Classical Mechanics*, Addison-Wesley Publishing, Reading, MA, 2nd edition, 1980; and Stefan Marinov in *Foundations of Physics* 8, 1978, pp. 137-156. The first to suggest a Sagnac-type rotating interferometer was Sir Oliver Lodge in 1897 (*Philosophical Transactions of the Royal Society*, London, 189, 149 (1897); R. Anderson, et al., *American Journal of Physics*, 62, 975, 1994). Based on classical physics, Lodge predicted the fringe shifts to be in accord with the formula $\Delta z = 4\Omega S/\lambda c$ where Ω is the constant angular velocity vector of the turntable, S is the vector representing the area enclosed by the light path, and λ is the wavelength of light *in vacuo*. The time difference of the fringe shifts comes out to be $\Delta t = \lambda \Delta z / c = 4\Omega S / c^2$. A few years prior to Sagnac's experiment, Franz Harres, graduate student of Jena, had unknowingly produced the Sagnac effect during experiments testing the Fresnel drag ("Die Geschwindigkeit de Lichtes in bewegten Korpern," Ph.D. dissertation, Univ. of Jena, Germany, 1912). It was P. Harzer, in 1914 (*Astronomische Nachrichten*, 199, 337) who discovered the anomaly in Harres' work as the Sagnac effect, after Sagnac had successfully produced it in 1913. Harres showed that the Sagnac fringe shift is unaffected by refraction.

⁷⁰⁵ *Comptes Rendus de l' Académie des Sciences* (Paris) 157, 1913, pp. 708-710, 1410-1413, as cited in *The Einstein Myth and the Ives Papers*, pp. 247-248. Einstein's biographer, Ronald Clark, who does not hide his favoring of Einstein, fails to mention Sagnac's experiment in his over 800+ page book. Instead, he makes a passing comment: "There might be debate over details, the third proof had not yet been obtained, and there were to be several attempts – all either unsuccessful or inconclusive – to show that the outcome of the Michelson-Morley experiment itself could be faulted" (*Einstein: The Life and Times*, p. 304).

directions upon one self-same horizontal circuit encompassing a definite area S. The rotating assemblage includes also the luminous source (a small electric lamp), and the receiver – a fine-grained photographic plate, which registers the interference fringes localized at the focus of a telescope. Photographs designated *cw* are obtained during a clockwise rotation of the platform; photos designated *ccw* are obtained during a counter-clockwise rotation of the same frequency. In these two kinds of photos, the center of the central fringe presents two different positions. I measure this displacement of the center of interference.⁷⁰⁶

Sagnac then explains what he will be observing:

In clear conception, it ought to be regarded as a direct manifestation of the luminiferous ether. In a system moving as a whole with respect to the ether, the elapsed time of propagation between any two points of the system should be altered as though the system were immobile and subject to the action of an *ether wind* which would blow away the light waves in the manner of atmospheric wind blowing away sound waves. The observation of the optical effect of such a relative wind of ether would constitute *evidence for the ether*, just as the observation of the influence of the relative wind of the atmosphere on the speed of sound in a system in motion would (in the absence of a better explanation) constitute evidence of the existence of the atmosphere around the system in movement.⁷⁰⁷

He then explains his results:

It has been very easy for me to find at the outset the evidence for the ether by causing a small optical circuit to rotate. A frequency N of 2 revolutions per second (successively in each direction) has furnished me a degree of relative whirling of the ether of $4\pi N$ or 25 radians per second. A uniform clockwise rotation of the interferograph produces, relatively, a counter-clockwise ether wind....The distance between the fringes is here from 0.5 to 1 millimeter....The observed interference effect is clearly the optical whirling effect due to the movement of the system in relation to the ether and directly manifests the existence of the ether, supporting necessarily the light waves of Huygens and of Fresnel.⁷⁰⁸

⁷⁰⁶ *Comptes Rendus, ibid.*

⁷⁰⁷ *Comptes Rendus, ibid.*, emphasis added.

⁷⁰⁸ *Comptes Rendus, ibid.* In an even more detailed explanation in the *Comptes Rendus* of December 22, 1913, pp. 1410-1413, Sagnac adds: “The result of the measurements demonstrates that, in ambient space, light is propagated with a velocity V_0 , independent

What is probably equally important is Sagnac's explanation for what appear to be "null" results in his experiment and, by extension, the null results of other similar experiments, namely, Michelson-Morley. As he explains it:

The total interferential displacement z is a constant fraction of the distance between fringes, for the same frequency N of rotation. The displacement becomes invisible on the photographs when the fringes have been adjusted to be narrow enough. Such a nullified result demonstrates that the normally observed displacement is clearly due to a difference of phase associated with the rotational movement of the system.⁷⁰⁹

In brief, what Sagnac's experiment shows is that, because one of the light beams took a longer time to reach the mirror moving away from it than the other light beam whose mirror was moving toward it, the postulate of Special Relativity (which holds that *the speed of light is the same for all observers*), does not hold. Clearly, there were two different speeds for the light beams traveling the same distance. So what is making one of the light beams travel slower? Sagnac said it was due to the ether impeding its velocity – a resistance that is easily generated by rotating the table. So predictable and precise are these results that the "Sagnac effect," as it is commonly called, is used routinely in today's technology for the purpose of sensing rotation, as well as mechanical

of the movement as a whole of the luminous source O and the optical system. That is a property of space which experimentally characterizes the luminiferous ether. The interferograph measures, as $\frac{1}{4} z\lambda V_0$, the relative circulation of the ether within the closed optical circuit." (Translated by Richard Hazlett). Sagnac added another article in *Journal de Physique et le Radium*, fifth series, 4, 1914, pp. 177-195.

⁷⁰⁹ *Comptes Rendus, ibid.* Interestingly enough, Sagnac's 1913 discovery of the ether was predicted by none other than Albert Michelson, as noted in *Philosophical Magazine*, London, sixth series, 8, 1904, pp. 716-719. He predicted that observers on Earth, if they are co-moving and co-rotating with the light source and screen, will observe an interference pattern that will be dependent on the absolute rotation of the system. Michelson did a similar experiment to Sagnac's with Henry Gale in 1925 and produced the same results. In 1925 B. Pogany reports a repeat of Sagnac's experiment with the same results (Über die Wiederholung des Harres – Sagnaschen Versuchs. *Ann. Phys.*, 1926, 80, p. 217-231). The same results were repeated by Dufour and Prunier and reported in 1937 (*Comptes Rendus* 204, 1925, 1937). The results were later confirmed with modern equipment and high precision by W. M. Macek and D. T. M. Davis, Jr., and as described in *Applied Physics Letters* 2, 1963, pp. 67-68. Sagnac interpreted his results, as did others in the scientific community, to nullify Special Relativity. (See: John Chappell, "Georges Sagnac and the Discovery of the Ether," *Arch. Internat. d'Histoire des Sciences*, 18:175-190, 1965; F. Selleri, *Foundations of Physics*, 26, 641, 1996; *Foundations of Physics Letters* 10, 73, 1997; J. Croca, *Nuovo Cimento B*, 114, 447, 1999; F. Goy, *Foundations of Physics Letters* 10, 17, 1997; J. P. Vigièr, *Physical Letters A*, 234, 75, 1997; P. K. Anastasowski et al., *Foundations of Physics Letters*, 12, 579, 1999).

gyroscopes. As noted above, in 1904 Albert Michelson had already predicted that observers on Earth, if they are co-moving and co-rotating with the light source and screen, will observe an interference pattern that is dependent on the absolute rotation of the system. This is precisely what Sagnac demonstrated, but using a laboratory turntable with two mechanical receivers instead of two human observers. Sagnac's interferometer is the "observer," and its light source and reflecting mirrors were all co-moving and co-rotating in one and the same fixed system. The only thing that Sagnac added from outside the system was putting the turntable in motion. Sagnac saw the equipment rotating, but the interferometer was the real, objective "observer," and it recorded fringe shifts in that observation, demonstrating that the speed of light was not constant. Today's Relativists, of course, conveniently dismiss this evidence and claim that Special Relativity does not work for rotating systems; or, they may insist it *does* work in rotating systems, but without revealing that it will not do so unless it adds in foreign elements belonging to General Relativity, such as "metric tensors" and the like.⁷¹⁰

We pause here to mention a very important consequence of Sagnac's experiment. In light of the experiment's clear demonstration of absolute motion, physicists of the Copernican yet non-Relativity variety have commonly interpreted Sagnac's results as being evidence for the absolute rotation of the Earth. From their cosmological perspective, this conclusion is certainly understandable. By the same token, however, if other evidence shows that Earth is not moving diurnally (which is strongly indicated by the stellar aberration experiments of Arago, Airy, et al.), then Sagnac's results would be positive proof for the absolute rotation of the universe around the Earth, as well as for the existence of ether and absolute space.

Sagnac's results (other than the fact that they bring science right back to the Maxwell/Fresnel/Arago/Airy ether) are so solid and irrefutable that current physics finds itself in the unenviable position of

⁷¹⁰ As noted in the previous footnote, Post and Goldstein, in order to coincide Sagnac with Relativity's assertion that the speed of light is constant only in an inertial frame, attempt to answer Sagnac by imposing an infinite sequence of inertial coordinate frames within the circumference of the rotating apparatus. Almost all others resort to using General Relativity to explain Sagnac, e.g., W. Schleich and M. O. Skully, "Course 10: General Relativity and Modern Optics," *New Trends in Atomic Physics*, Elsevier Science Publishers, Amsterdam-New York, 1982; M. A. Tonnelat, *Les principes de la théorie électromagnétique et de la relativité*, Masson, Paris, 1959; Oyvind Grøn, "Relativistic Description of a Rotating Disk," *American Journal of Physics* 43, 10:869f, 1975; G. Rizzi and M. Ruggiero, *Relativity in Rotating Frames*, Kluwer Academic Publishers, Dordrecht, 203; G. Rizzi and A. Tartaglia, "Speed of Light on Rotating Platforms," *Foundational Physics*, 28:1663, 1998; Berenda, "The Problem of the Rotating Disk," *Physical Review* 62:280f, 1942; Ashtekar and Magnon, "The Sagnac Effect in General Relativity," *Journal of Mathematical Physics*, 16, 2:341, 1975; J. -F. Pascual Sánchez et al., "Geometry of an Accelerated Rotating Disk," Universidad de Valladolid, Spain, 2003. See section in "Does Ether Exist" for General Relativity's answer for rotating discs.

having to use Sagnac's discovery to make their Relativistic formulas function. The popular Global Positioning System, for example, cannot function properly without adjustments based upon Sagnac's experimental results.⁷¹¹ Not surprisingly, then, whenever the need arises for inertial navigation (i.e., an absolute frame from which to measure all other coordinates), the Sagnac effect is always included.⁷¹² The Sagnac effect is a universal principle for all electromagnetic counter-propagating beams, as well as neutron beams, de Broglie waves and even sound waves, that is, any waves which travel in opposite paths in an enclosed path of a rotating device.⁷¹³ All the various beams and waves show the same time differences, both for matter and light, independent of the physical nature of the interference. These various testing elements show that the Sagnac effect is not dependent on the nature of light, per se, but solely on the principle of absolute motion. Ring laser experiments have confirmed the Sagnac effect to within one part in 10^{20} , a truly remarkable verification.⁷¹⁴

⁷¹¹ See Appendix 7: "The Global Positioning System."

⁷¹² *Laser Applications*, ed. Monte Ross, written by F. Aronowitz, New York, Academic Press, 1971, vol. 1, pp. 133-200; E. J. Post, *Review of Modern Physics*, 39, 2, 475, 1967; W. W. Chow et al., *Review of Modern Physics*, 57, 61, 1985; V. Vali and R. W. Shorthill, *Applied Optics*, 15, 1099, 1976; G. E. Stedman, *Rep. Prog. Phys.* 60, 615, 1997. The Sagnac effect has been measured not just with light waves, but also with matter waves using Copper pairing (J. E. Zimmermann and J. E. Mercerau, *Physical Review Letters*, 14, 887, 1965); with neutrons (D. K. Attwood et al., *Physical Review Letters*, 52, 1673, 1984; S. A. Werner et al., *Physical Review Letters*, 42, 1103, 1979); and Ca⁴⁰ atom beams (F. Riehle et al., *Physical Review Letters*, 67, 177, 1991); and with electrons (F. Hasselbach and M. Nicklaus, *Physical Review A*, 48, 143, 1993).

⁷¹³ Cf., Anderson et al., *American Journal of Physics*, 62, 11:975, 1994 and Post, "Sagnac Effect," *Review of Modern Physics* 39, 2:475, 1967 showing the Sagnac effect in ring interferometers; Hasselbach and Nicklaus, *Physical Review A*, 48, 1:143, 1993 showing Sagnac effect using electrons.

⁷¹⁴ Much of the research comes from the Canterbury Project. Some of the many reports include: H. R. Bilger, G. E. Stedman, Ziyuan Li, U. Schreiber and M. Schneider, Ring lasers for geodesy, IEEE Transactions on Instrumentation and Measurement (special issue for CPEM/94: Conference on Precision Electromagnetic Measurements, Boulder CO, June 27-July 1, 1994) 44: 468-470, 1995; H. R. Bilger, U. Schreiber, and G. E. Stedman, "Design and application of large perimeter ring lasers," Symposium Gyro Technology, Stuttgart, Germany, 17-18 September 1996; V. Rautenberg, N. P. Plag, M. Burns, G. E. Stedman and H. U. Juttner, "Tidally induced Sagnac signal in a ring laser," *Geophys. Res. Lett.* 24, 8, 893-896, 1997; R. Anderson, H. R. Bilger and G. E. Stedman, "The 'Sagnac' effect: a century of earth rotated interferometers," *American Journal of Physics* 62: 975-985, 1994; H. R. Bilger, G. E. Stedman, M. P. Poulton, C. H. Rowe, Li Ziyuan and P. V. Wells, "Ring laser for precision measurement of non-reciprocal phenomena," IEEE Transactions on Instrumentation and Measurement 42: 407-411, 1993; G. E. Stedman, K. U. Schreiber and H. R. Bilger, "On the detectability of the Lense-Thirring field from rotating laboratory masses using ring laser gyroscope interferometers," *Classical Quantum Gravity* 20, 13: 2527-2540, 2003; G. E. Stedman and B. G. Wybourne, "Beyond the sixth place of decimals: From Michelson to large ring lasers," *Bulletin de la Société des Sciences et des Lettres de Łódź* 53 (Série:

To escape the embarrassment, Relativists will claim many and varied reasons for Sagnac's results.⁷¹⁵ One theory, promoted by French physicist [Paul Langevin](#) in 1921,⁷¹⁶ held that due to Relativity's principle of co-variance, the universe can be thought of as rotating around Sagnac's stationary platform, and thus the universe's "radiant energy" is dragging the light in the interferometer around with it. This circular motion of the universe creates a centripetal acceleration toward the center of rotation. It was admitted later, however, that this solution would involve changing the speed of light from a constant value, not to mention allowing for an Earth in the center of a rotating universe. In 1937, Langevin proposed another solution. This time he introduced the idea of "non-uniform local time," thus allowing for a constant value for the speed of light. In the following year of 1938, Herbert Ives showed that Langevin's 1937 proposal would end up making two clocks that were operating on "non-uniform local time" tell different times in the same place. As Ives put it: "The performer of the experiment must avoid looking at both clocks at once!" Ives also showed that Langevin's 1921 solution was not viable, since Sagnac's experiment involves no consideration of rotation.⁷¹⁷ Unfortunately, Ives' explanation has been

Recherches sur les déformations vol 39): 47-56, 2003; U. Schreiber, M. Schneider, C. H. Rowe, G. E. Stedman, S. J. Cooper, W. Schlüter and H. Seeger, "The C-II ring laser project," *Phys. Chem. Earth A* 25 (12): 805-807, 2000; C. H. Rowe, K. U. Schreiber, S. J. Cooper, B. T. King, M. Poulton and G. E. Stedman, "Design and operation of a very large ring laser gyroscope," *Applied Optics* 38 (12): 2516-2523, 1999; G. E. Stedman, "Ring laser tests of fundamental physics and geophysics," *Rep. Prog. Phys.* 60: 615-688, 1997.

⁷¹⁵ For example, "The Sagnac Phase shift suggested by the Aharonov-Bohm effect for relativistic matter beams," Guido Rizzi et al., May, 2003. Rizzi includes a list of about a half-dozen Relativists. Suffice it to say, Rizzi's paper is filled with a dizzying array of mathematical contrivances and contortions in order to explain Sagnac from a Relativistic point of view.

⁷¹⁶ *Comptes Rendus* 173, 831-834, 1921.

⁷¹⁷ "Light Signals Sent Around a Closed Path" in the *Journal of the Optical Society of America*, April 16, 1938, Vol. 28. Ives writes: "The net result of this study appears to be to leave the argument of Sagnac as to the significance of his experiment as strong as it ever was. The suggested use of 'local time' merely offers another way of measuring the effect of rotating the apparatus, namely in terms of the differences between two clocks carried around a circuit, instead of difference of arrival time of two light signals sent around the same circuit. The rotation, which can be measured in either of these ways, is not relative rotation of the apparatus with respect to the platform on which it is mounted, or to the laboratory – either of these might be rotated with respect to the apparatus, with no resultant Sagnac effect. The observer on the apparatus has just one reference framework by which he can predict whether the Sagnac effect will appear or not; that framework is the pattern of radiant energy from the stars. If his apparatus rotates with respect to the stars he will observe a Sagnac effect, if it does not, then no matter how great relative rotation it exhibits with respect to its material surroundings, there will be no Sagnac effect."

totally ignored in the physics literature. This is no surprise, considering Langevin's *ad hoc* attempts at trying to deal with Sagnac's results to salvage Relativity. Langevin also tried to argue that, although Special Relativity could not answer the centrifugal effect, General Relativity could proffer an answer, since a centrifugal force would not exist if all other gravitational forces were eliminated from the universe. This was obviously a question-begging proposal, since its terms would be impossible to satisfy, and as such, it disproved Langevin's proposal by itself.

There is even more here than meets the eye. In the first case, although Langevin's suggestion that the universe's rotation causes the Sagnac effect was a convenient Relativistic attempt at solving the problem, in effect, it helps show precisely what the geocentrist argues regarding the Earth's motionlessness. That is, if Relativists insist on resorting to a universe in rotation against a stationary Earth in order to explain the Sagnac experiment, then there is no great leap in proposing that this is precisely what occurs in reality, and against which the Relativist cannot mount any satisfactory objections, since the very principle of equivalence posits that there is no difference between a rotating universe around a stationary Earth and the Earth spinning inside a stationary universe. In effect, the only thing Relativity's equivalence principle accomplishes is a reopening of the dispute between Galileo and the Catholic Church, with the latter side holding much more scientific evidence than it did in 1633. As Einstein admitted: "It follows from this that our notions of physical reality can never be final. We must always be ready to change these notions..."⁷¹⁸ Or, as Martin Gardner stated it for the Relativity enthusiast:

Indeed from the standpoint of relativity the choice of reference frame is arbitrary. Naturally, it is simpler to assume the universe is fixed and the Earth moving than the other way around, but the two ways of talking about the Earth's relative motion are two ways of saying the same thing.⁷¹⁹

As we will see later, it is precisely the matter concerning the equivalence principle that [Mach](#) argued with Einstein in their personal letters, and the very principle from which Einstein formed his own Relativity theory. In fact, in the Machian model, the gravity of the stars (in rotation with the universe around a stationary Earth) provided the long sought-after physical/mechanical answer to why centrifugal force exists, that is, because the gravity of the stars is pulling on the object. As Clark writes of Einstein:

⁷¹⁸ Albert Einstein, *Ideas and Opinions*, New York, Wing Books, 1984, p. 266.

⁷¹⁹ Martin Gardner, *The Relativity Explosion*, New York: Random House, 1976, p. 185.

The idea that the system of fixed stars should ultimately determine the existence of centrifugal force was an important part of the conceptual background to the General Theory of Relativity. This was not a new idea and had been put forward in general terms by both Berkeley and Mach.⁷²⁰

Models that depend solely on a moving Earth (without consideration of the gravity of the stars) have no such recourse and must resort to viewing the centrifugal and Coriolis phenomena as secondary effects, not as primary forces.

Second, Langevin's dependence on the "radiant energy" of the universe as the medium which moves against Sagnac's stationary apparatus shows, once again, that, although Relativists keep insisting that there is no ether medium between Earth and the stars, they are forced, nevertheless, to resort to it to explain the effects of experiments that are utterly dependent on its inclusion. To paraphrase Shakespeare, a rose by any other name is still a rose, and "radiant energy," by any other name, is still some type of ether medium.

⁷²⁰ *Einstein: The Life and Times*, p. 266.

The Michelson-Gale Experiment of 1925: A Confirmation of the Sagnac Experiment

Since, with Langevin's admission, Sagnac's experiment was performed with reference to the stars, not the apparatus, Albert Michelson must have been very intrigued by the result of Sagnac's 1913 experiment, for it showed an effect that was demanding an adjustment to his conclusion from the experiment he performed with Edward Morley in 1887. Sagnac had established quite conclusively that light, as it travels around a closed circuit, does not have a constant speed unless it is understood to be traveling in absolute space. With Langevin's failure, and with that, General Relativity's failure to explain Sagnac's results, Michelson was forced back to the drawing board. Michelson knew he had to create a more sophisticated apparatus to test for ether than his 1887 effort. Since Morley had died in 1923, Michelson found a new partner, Henry G. Gale, a man who demonstrated such devotion to the effort that he was named as a co-author. The newspapers had picked up on the story and, advertising it with all the drama of Hollywood, wrote headlines such as "Einstein on Trial" or "Michelson Leads Flank Attack Upon the German Scientist." In any case, Michelson's abstract states the following:

Theory of the effect of the rotation of the Earth on the velocity of light as derived on the hypothesis of a fixed ether. Historical Remarks: The theory was given originally in 1904. The experiment was undertaken at the urgent instance of Dr. L. Silberstein. A preliminary experiment at Mount Wilson in 1923 showed that it was necessary to resort to an exhausted pipeline.

Ludwik Silberstein, a physicist himself, was so insistent because he had written an article in 1921 discussing the difficulty Relativity theory might have in explaining optical rotational phenomena.⁷²¹ Perhaps Silberstein, unlike Einstein, had not dismissed the Sagnac experiment that occurred just eight years earlier. In any case, the preliminary experiment performed at Mt. Wilson used a mile-long circuit for the light path. The tests showed that

The interference fringes...were observed most clearly during the half-hour before and after sunset. But even under the best conditions, the interference fringes were so unsteady that it was found impossible to make any reliable measurements.⁷²²

⁷²¹ *Journal of the Optical Society of America* 5: 291-307, 1921.

⁷²² "The Effect of the Earth's Rotation on the Velocity of Light," Part I, by A. A. Michelson. *The Astrophysical Journal*, April 1925, Vol .LXI, No. 3.

To eliminate the effects of air, Michelson and Gale reassembled the mile-long, one-foot-wide watermain pipe. The second abstract reads:

Experimental Test of Theory: Air was exhausted from a twelve-inch pine line laid on the surface of the ground in the form of a rectangle 2010×1113 feet. Light from a carbon arc was divided at one corner by a thinly coated mirror into direct and reflected beams, which were reflected around the rectangle by mirrors at the corners. The two beams returning to the original mirror produced interference fringes. The beam traversing the rectangle in a counter-clockwise direction was retarded. The observed displacement of the fringes was found to be $0.230 \pm .005$, agreeing with the computed value $0.236 \pm .002$ within the limits of experimental error.⁷²³

The tests were made on thirteen different days with a total of 269 observations, almost always with the same results. The lowest value for the displacement in the fringes was 0.193 while the highest was 0.255 with the mean displacement coming in at 0.230. Thus, right before Michelson's own eyes, the 1913 Sagnac results were confirmed and his 1887 interpretation was put in question, as was Relativity. Here was further proof, to the order of ten times the power of the Sagnac experiment, that there is, indeed, an absolute space in which absolute rotation occurs. Something was affecting the light in order for it to consistently produce the fringe displacement. Sagnac (1913) and Michelson (1925) demonstrated it was ether, which was quite an irony for the latter. Although Michelson would sum up the experiment with the sardonic comment: "All we can deduce from this experiment is that the earth rotates on its axis,"⁷²⁴ in reality, the experiment did not distinguish between an Earth rotating against the ether as opposed to the ether circling around a fixed-Earth. In other words, it provided no proof that the Earth rotates, but opened the door very wide to suggest that Copernicus was wrong, since no translational motion corresponding to 30 km/sec was found by Michelson and Gale.

Analyzing the results of the Sagnac and Michelson-Gale experiments, Hayden and Whitney, in the revealing title: "If Sagnac, Why Not Michelson-Morley?" write:

The logical existence of the incremental Sagnac effect implies...that there is some compelling physical reason why the effect cannot be observed at the surface of the Earth....We hold that until something new is brought to the table, this question simply cannot be resolved. No currently accepted

⁷²³ *Ibid.*, Part II.

⁷²⁴ Quoted by A. H. Compton in an interview with Michelson's daughter Dorothy Michelson Livingston, as cited in *The Master of Light*, p. 310.

theory reveals why, like a Cheshire cat, the Sagnac effect shows itself in one kind of experiment but not in another.⁷²⁵

The authors are certainly correct in concluding, “until something new is brought to the table, this question simply cannot be resolved.” The resolution staring them in the face but which has been “unthinkable” since the days of Lorentz and Einstein is that the Earth is not moving. Whereas Sagnac and Michelson-Gale, being themselves Copernicans, were testing for “The Effect of the Earth’s Rotation on the Velocity of Light,” the interpretation of their results in regard to a geocentric universe is, as we stated earlier, that Earth is motionless at the center of the universe. There is a slight movement of the ether against “the surface of the Earth” due to the rotation of the universe, which then shows up in miniscule fringe shifts in the interferometer experiments. Accordingly, since the Earth has no translational motion, experiments seeking to detect such motion will always come to a “null” result. The result, as we have seen, is not actually null; rather, all the experiments show a slight positive result (as did the original Michelson-Morley experiment in 1887), but the physicists and astronomers interpreting the results consider them null because they do not produce the *expected* fringe shifts if the Earth is understood to be moving through the ether by revolving around the sun at 18.5 miles/sec. In other words, if one presupposes a revolving and rotating Earth, the fringe shifts are always too small to account for such double motion. But if we assume a stationary Earth in the center of a universal ether, there will, indeed, be as slight a movement of the ether against Earth as there would be against a ship in the eye of a hurricane.

Considering the unanswerable problems the Sagnac and Michelson-Gale experiments present to modern physics and cosmology, it is no surprise that both experiments are hardly mentioned, if at all, in the physics literature,⁷²⁶ and it is likewise no puzzle why Einstein makes

⁷²⁵ Howard C. Hayden and Cynthia K. Whitney, “If Sagnac and Michelson-Gale Why Not Michelson-Morley?” *Galilean Electrodynamics*, vol. 1, no. 6, Tufts University, Nov./Dec. 1990, pp. 73-74.

⁷²⁶ Hayden and Whitney write: “More so than the original Sagnac experiment, the subsequent Michelson-Gale demonstration of the Sagnac effect is curiously neglected in the literature. R. D. Sard [*Relativistic Mechanics*, W. A. Benjamin, Inc., New York, 1970] comments only that the Michelson-Gale experiment determined the Earth’s angular velocity to within 2.5%. L. S. Swenson [“Michelson and Measurement,” *Physics Today* 40, 24, 1987] recently devoted only 22 words to the experiment, calling it ‘an attempt at a large field in Clearing, Illinois, to measure the effect of the Earth’s rotation on the velocity of light.’ In 55 references, E. L. Hill [“Optics and Relativity Theory,” *Handbook of Physics*, E. U. Condon, ed., McGraw Hill, 1967] does not list the Michelson-Gale experiment. In a list of some 1600 references, C. W. Misner, K. S. Thorne, and J. A. Wheeler [*Gravitation*, W. H. Freeman, New York, 1973] make no mention of Michelson-Gale [neither do they mention Sagnac]...Moreover, the Michelson-Gale paper is not mentioned in *any* of the famous papers which claim to measure the velocity of light, or to compare light speeds in various directions” (“If

no mention of these crucial experiments in any of his writings.⁷²⁷ Obviously, without at least Sagnac's results in hand, Einstein was on a wild goose chase. As noted above, it was left to Langevin to explain Sagnac, but he found it impossible to do.

Sagnac and Michelson-Gale Why Not Michelson-Morley?" Howard C. Hayden and Cynthia K Whitney, Tufts University, Nov./Dec. 1990). Dean Turner, writing in 1979, points out that the 1971 *McGraw-Hill Encyclopedia of Science and Technology*, the 1974 *Encyclopedia Britannica*; the 1976 *Encyclopedia Americana*, and the *Encyclopedia of Philosophy* of 1967 all fail to mention the Sagnac or Michelson-Gale experiments. McGraw-Hill conceded to write an article on ether for the 1977 edition, but still failed to mention Sagnac and Michelson-Gale, two of the most important experiments in the annals of physics (*The Einstein Myth*, pp. 44, 102).

⁷²⁷ Einstein's biographer, Ronald Clark, makes no mention of either the Sagnac or the Michelson-Gale experiment in the entire 878 pages of the book. He makes brief mention of Dayton Miller but only to downplay his results. Stephen Brush in "Why was Relativity Accepted?" (*Physics in Perspective* 1: 184-214, 1999, makes no mention of Sagnac, Michelson-Gale or Miller, but has at least a dozen references to Michelson-Morley. Bernard Jaffe cites Miller, but makes the erroneous conclusion: "...no shift in interference effect was observable," when, in fact, a shift was, indeed, observable (Bernard Jaffe, *Michelson and the Speed of Light*, p. 107). Also during this time came the experiment by Mixer in 1925, who used sunlight rather than artificial light in the interferometer (as had been suggested by both Tolman (*Physical Review* 35:136, 1912 and La Rosa (*Phys. Zeitschrift* 13:1129, 1912), but apparently with the same results. (See also Edmund Whittaker's *A History of the Theories of Ether and Electricity: The Classical Theories*, first edition 1910; revised 1951, Nelson and Sons, Ltd., London).

The Interferometer Experiments of Dayton C. Miller

Next in this line of argumentation are the comprehensive results of [Dayton Miller's](#) interferometer experiments. As noted previously, although Einstein seemed to escape the purview of Sagnac and Michelson-Morley, this was not the case with Miller. In addition to the previous quotes from Einstein we cited showing that Miller was hot on his trail, several more show how nervous Einstein became over Miller's undaunted quest. In a letter Einstein once wrote to Edwin E. Slosson, he states:

My opinion about Miller's experiments is the following....Should the positive result be confirmed, then the special theory of relativity and with it the general theory of relativity, in its current form, would be invalid....Only the equivalence of inertia and gravitation would remain, however, they would have to lead to a significantly different theory.⁷²⁸

Miller's experiments, conducted over a period of 20 years, showed time and time again the same thing that Sagnac and Michelson-Gale had found – slight fringe shifts in the interferometer that indicated ether as the cause. In fact, Miller wasn't boasting of anything he had discovered; rather, he made it clear that he was acquiring the same positive results that Michelson-Morley obtained way back in 1887. As Arthur Lynch reveals:

Dayton Miller, in a letter dated 4th October, 1930, says that 'It is true that nearly all the writers at the present time interpret the experiments as giving a definite null effect, and most of them assume that it is final. The truth of the matter is the experiment never gave a null effect. My present determinations are exactly in agreement with the 1887 results of Michelson and Morley. This fact has been widely announced especially in England, but the theory of relativity seems to be so acceptable to many persons that they overlook the apparent discrepancy.'⁷²⁹

Miller's experiments even went a little beyond Sagnac and Michelson-Gale. Whereas the latter discovered absolute motion by detecting differences in the speed of two light beams in the same

⁷²⁸ July 1925. As quoted from the paper by Dr. James DeMeo: "Dayton Miller's Ether-Drift Experiments: A Fresh Look," 2002. (NB: This book does not endorse any of the other theories of DeMeo, e.g., his "orgone biophysical" research). Miller performed his experiments on the top of Mt. Wilson. Sadly, DeMeo reports: "Today, I am informed, there is no record of Miller's extensive work at Mt. Wilson, only a memorial plaque dedicated to Michelson and Einstein" (p. 12).

⁷²⁹ *The Case Against Einstein*, p. 45.

medium, they were not designed to detect the actual drift of the medium against Earth. Miller's results showed that an ether drift was originating from the southern celestial hemisphere in the direction of the constellation Draco in the middle of the Great Magellanic Cloud.⁷³⁰ It wasn't as easy for Einstein to ignore Miller as to ignore Sagnac. Sagnac was a French physicist, and except for Paul Langevin noted earlier, most French scientists were ignoring or had outright rejected Relativity, until at least about 1950.⁷³¹ Miller was an American. After Germany, the United States was the next country to fully embrace Relativity, and Einstein had already emigrated to the United States. Moreover, Miller earned his doctorate in science in 1890 from the prestigious Princeton University (the same institution at which Einstein would eventually have a professorship), as well as being president of both the American Physical Society (1925-1926) and Acoustical Society of America (1913-1933). He was chairman of the division of Physical Sciences of the National Research Council (1927-1930), and chairman of the physics department of Case School of Applied Science (aka: Case Western University). He was also an active member of the National Academy of Sciences. In short, Miller was a force with which to be reckoned. It is safe to say that, with his expertise Miller performed the most extensive and sophisticated interferometer experiments ever devised. He used the largest and most sensitive equipment to date. He floated the device on a pool of mercury to eliminate friction (at great expense), and used different bases: wood, metal and concrete. He did tests at different times of the day, different seasons of the year, different altitudes, different latitudes and with different light sources. He took precautions against thermal distortions by insulating the apparatus in one-inch cork and by applying uniform parabolic heaters and taking account of human body heat. He covered the interferometer in glass so that drift would not be inhibited. He used a 50× magnification telescope to observe the fringes,

⁷³⁰ The right ascension from Draco was 4 hours 54 minutes, with declination of $-70^{\circ} 33'$, in the middle of the Great Magellanic Cloud and 7° from the southern pole of the ecliptic. Since Miller believed the Earth moved, he phrased his results in the language that the Earth was drifting toward Draco, rather than the ether drifting from the direction of Draco toward Earth. Miller found that the ether drift was 208 km/sec but at the surface of the Earth the drift was 10 km/sec, since the ether was mostly entrained at the Earth's surface ("The Ether-Drift Experiments at Mount Wilson Solar Observatory," *Physical Review*, 19:407-408, 1922). His results in Cleveland showed a 3 km/sec drift, which was very close to what Michelson-Morley had found in 1887 in their basement facility. The contrast between the Cleveland and Mt. Wilson results shows that the closer the equipment is to the surface of the Earth, the less movement of ether against it. The science community (which was favoring Relativity) could tolerate Miller's 3 km/sec results, since those results correlated with Michelson-Morley and were already considered "null." But they did not like his 10 km/sec results, which he first obtained in 1921 using the same equipment that he and Morley had used in 1905. The same results were obtained again in 1922-1924 using controlled experiments.

⁷³¹ See Brush, "Why Was Relativity Accepted?" p. 194.

which allowed him to see down to the hundredth scale. Miller even switched to an interferometer made of aluminum and brass to eliminate possible effects from magneto-constriction. Over all, he took over 200,000 different readings from 1902-1926. By contrast, the 1887 Michelson-Morley had a grand total of 36 readings on an apparatus that was much smaller and less accurate. It was covered in wood and situated in the basement of a large stone building, both of which limit the sensitivity since such insulated locations will shield much of the ether drift. And still, they managed to obtain a small positive result, as they themselves admitted. Thus, Einstein had a lot to worry about since, if Miller's result was correct, and it seemed so, by Einstein's own verbatim admission, Miller would totally destroy Relativity theory. The battle between Miller and Einstein went on for some years. Miller never conceded his findings, and Einstein never conceded that Miller was correct. Between 1921 and 1933, Miller, who had previously teamed up with Edward Morley in 1903 and 1904 in two separate interferometer experiments, performed over 100,000 trials. This was hardly a scientific force that Einstein could ignore.⁷³²

Miller and Einstein were exchanging letters for a few years. So alarmed was Einstein by the results of Miller's experiments that he stated quite plainly to one of his colleagues: "If Michelson-Morley is wrong, then relativity is wrong."⁷³³ In a private letter to Robert J. Millikan, Einstein wrote: "I believe that I have really found the relationship between gravitation and electricity, assuming that the Miller experiments are based on a fundamental error. Otherwise the whole relativity theory collapses like a house of cards."⁷³⁴ A follow-up letter three months later stated: "Privately I do not believe in the accuracy of Miller's results, although I have no right to say this openly."⁷³⁵

But Einstein had said it openly enough that in 1926 a Cleveland newspaper picked up the story and wrote both the following headline: "Goes to Disprove Einstein Theory: Case Scientist Will Conduct Further Studies in Ether Drift: Einstein Discounts Experiments" and this subsequent article:

⁷³² D. C. Miller, "The Ether-Drift Experiment and the Determination of the Absolute Motion of the Earth," *Reviews of Modern Physics* 5, 352-367, 1933.

⁷³³ Stated to Sir Herbert Samuel in the grounds of Government House, Jerusalem. *Einstein: The Life and Times*, p. 107.

⁷³⁴ Letter to Robert Millikan, June 1921, *Einstein: The Life and Times*, p. 400.

⁷³⁵ Letter to Robert Millikan, September 1921. *Ibid.* Or as Einstein once said to astronomer Erwin Freundlich in 1913: "If the speed of light is in the least bit affected by the speed of the light source, then my whole theory of relativity and theory of gravity is false" (*ibid.*, p. 207).

Speaking before scientists at the University of Berlin, Einstein said the ether drift experiments at Cleveland showed zero results, while on Mount Wilson they showed positive results. Therefore, altitude influences results. In addition, temperature differences have provided a source of error. “The trouble with Prof. Einstein is that he knows nothing about my results,” Dr. Miller said. “He has been saying for thirty years that the interferometer experiments in Cleveland showed negative results. We never said they gave negative results, and they did not in fact give negative results. He ought to give me credit for knowing that temperature differences would affect the results. He wrote to me in November suggesting this. I am not so simple as to make no allowance for temperature.”⁷³⁶

One of the interesting features of Miller’s results is that they were calculated in relation to sidereal time, that is, against the displacement between a star and the Earth, as opposed to the sun and the Earth. The former time yields 23 hours, 56 minutes and 4.09 seconds; the latter 24 hours exactly.⁷³⁷ This shows that the ether is drifting in relation to the stars, and thus gives a more definitive picture of absolute motion.

But we must pause at this juncture to critique Miller’s thinking process, for he, being a Copernican, is basing his interpretation of data on his belief that the Earth is moving at least 30 km/sec through space. Interestingly enough, it is precisely because of this presupposition that Miller runs into some unexplained difficulty, since his observations begin to conflict with his mathematical calculations. The one anomaly in all past interferometer experiments that Miller discovered was the experimenters *assumed* they knew the precise velocity of the Earth through the ether in combination with the solar system’s supposed motion toward the constellation of Hercules, but did they really know? The geocentrist, of course, would answer that they *did not* know. In any case, Miller’s 1925 experiment took into account this “anomaly” and he made his calculations accordingly. Since he assumed the Earth was moving 30 km/sec, he combined this with the four positions (February, April, August, September) that he examined of the Earth’s orbit around the sun and then used Pythagorean geometry to determine the speed of

⁷³⁶ *Cleveland Plain Dealer*, 27 Jan. 1926. In 1930, *Scientific American* remarked on the issue: “Let a world of blind admirers and enraged detesters of a theory beat the air with super-heated syllables, Einstein serenely smokes his pipe and says ‘If Professor Miller’s research is confirmed, my theory falls, that’s all.’ And Miller, standing before his assembled peers in science, is almost apologetic about his findings, but indicates that “there they are” (March 1930). Einstein wrote this article for *Scientific American* for the April 1950 issue.

⁷³⁷ In the same way, in sidereal time (i.e., star time), the moon travels around the Earth in 27.33 days, as opposed to 28 days as measured only from Earth.

the Earth toward the constellation Draco, which came to 208 km/sec.⁷³⁸ In other words, 208 km/sec is what Miller believed to be the Earth's absolute speed through the ether. Of course, being a heliocentrist, Miller is assuming that the ether is motionless and that the Earth is moving through it. In any case, Miller's 1933 paper reveals that his Pythagorean calculations do not match what he observed in the fringe shifts. As we will recall, his fringe shifts showed a maximum of 10 km/sec, but this figure is less than his computed value by a factor of twenty! Miller did not have an answer for this problem, and it is left as an open-ended question in his 1933 paper. The answer, of course, is that Miller's Pythagorean calculations were based on a faulty premise (i.e., that the Earth was moving at 30 km/sec). If that factor were eliminated, his calculations would be in accord with his observations. The same can be said of recent experiments performed by Stefan Marinov, in the late 1970s, using coupled-mirror interferometry.⁷³⁹

⁷³⁸ Miller made a parallelogram of the four points he took interferometer readings (February, April, August, September), which assumes the Earth is in orbit around the sun. The diagonal of each of the four parallelograms represents the apex of that period, while the long side represents the motion, which is coincident with the center of orbit; the short side of the parallelogram represents Earth velocity of 30 km/sec. Hence, knowing the direction of the three sides of the triangle, and the magnitude of one side, allows one to calculate the magnitude of the other sides, which for Miller was 208 km/sec toward Dorado. (See also Laurence Hetch in *21st Century – Science and Technology*, Spring 1988, pp. 47-48.)

⁷³⁹ Stephan Marinov, whose experiments show an ether-drift of 279-327 km/sec, declares that the Earth is moving through it toward the midpoint of the constellations Virgo, Hydra and Libra (J. P. Wesley, *Galilean Electrodynamics*, "In Memorium: Stefan Marinov, Spring 1999, pp. 11-12; S. Marinov, *General Relativity and Gravity* 12, 57, 1980b). Also *Czechoslovakia Journal of Physics* B24:965, 1974, and *Eppur Si Muove* (Brussels: CBDS-Pierre Libert, 1977, pp. 101-111, the latter cited in Bouw, *Geocentricity*, p. 257). Obviously, Marinov's calculations are close to those of Dayton Miller's 1925 interferometer experiments, but, as Miller had, he used heliocentric geometry in arriving at his 300+ km/sec. E. W. Silvertooth, after having had "null" results in 1972 with frequency-doubling crystals (*Journal of the Optical Society of America*, 62:1330), had similar results to Marinov in a 1983 experiment. He claims that laser-interferometer experiments analogous to the Michelson-Morley apparatus give a null result because frequencies of the interfering beams are dependent upon velocity relative to a stationary frame. Hence, the frequency adjusts precisely enough to cancel any effects due to the motion through the light's reference frame, and a null result is the inevitable consequence. This, claim, of course, assumes that the "velocity" is caused by an Earth moving at 30 km/sec and that light has its own "reference frame." Another study performed by Smoot, Gorenstein and Muller also sought to find motion of the Earth (*Physical Review Letters*, 39, 898, 1977). As reported by Michael Rowan-Robinson, the quest was to find a "dipole anisotropy of order 10^{-4} to 10^{-3} ...due to the random motions that galaxies have with respect to each other and to the cosmological frame of reference. The radiation should look slightly hotter in the direction we are traveling towards, and slightly colder in the direction we are traveling from, by an amount $\Delta T/T \approx v/c$, due to the Doppler shift." This study was important to them because "Failure to detect this effect would put us in the uncomfortable position of happening to be exactly at rest with respect to the cosmological frame." In other words, it would show the Earth at the center and immobile in space. Although the Smoot team, similar

A number of years after Miller's death in 1941 his experimental results were formally addressed. Perhaps not being able to dismiss Miller's haunting words, in 1954, a year before his own death, Einstein employed the services of Robert S. Shankland to investigate Miller's findings. The notes reveal that the two men had "extensive consultations" about Miller. Ironically, [Shankland was one of Miller's students](#) for many years, and only began to favor Einstein's Relativity after Miller died. His career soared after he decided to declare Miller's work as worthless. He also accused Miller of indirectly prohibiting Einstein from receiving the Nobel Prize for Relativity. Perhaps another irony is that Shankland's report on Miller was published in 1955, in the same month and year of Einstein's death.⁷⁴⁰ It was full of misrepresentations as well as appeals to criticisms that had already been thoroughly addressed years earlier. He searched for and emphasized the random errors in Miller's data (which every experiment has) and selected only certain data sheets to examine – those in which Miller used a parabolic heater. Since Miller himself noted in preliminary trials that

to the Rubin team, found an anisotropy, it made little sense and did not get them out of the "uncomfortable position." As Rowan-Robinson reveals, "the magnitude of the velocity deduced for the Milky Way, 600 km/sec, is so large as to throw existing ideas about our cosmic environment into disarray." In addition, "The authors note that the velocity they have found conflicts with various attempts to measure our velocity with respect to nearby galaxies, but offer no explanation of this. With respect to the Local Group of galaxies, the motion of the Solar System hardly differs from that expected due to our circular motion round the Galaxy. This suggests that the whole Local Group has to be moving along together at this velocity of 600 km/sec with respect to the microwave background" (Michael Rowan-Robinson, "Ether drift detected at last," *Nature*, Vol. 270, November 3, 1977, p. 9). We note here that the Smoot team did not find a velocity of the Earth, but only a velocity of the solar system and the Local group. Reginald T. Cahill reports that at least seven experiments have detected a translational velocity; some with gas-mode interferometers and others with coaxial cable (DeWitte 1991), with a result of around 430 km/sec (R. T. Cahill, "Quantum Foam, Gravity and Gravitational Waves," *Relativity, Gravitation, Cosmology*, eds. V. V. Dvoeglazov and A. A. Espinoza, New York: Nova Science Publication, 2004, pp. 168-226; R. T. Cahill, "Absolute Motion and Gravitational Effects," *Apeiron*, 11, No. 1, 2004, pp. 53-111). In another paper Cahill writes: "Physics has been in an era of extreme censorship for a considerable time; Miller was attacked for his major discovery of absolute linear motion in the 1920's, while DeWitte was never permitted to report the data from his beautiful 1991 coaxial cable experiments. Amazingly these experimenters were unknown to each other, yet their data is in perfect agreement....All discussions of the experimental detections of absolute motion over the last 100 years are now banned from the mainstream physics publications" (Reginald T. Cahill, *The Einstein Postulates: 1905-2005: A Critical Review of the Evidence*, Flinders University, Adelaide, Australia, December 7, 2004.)

⁷⁴⁰ "R. S. Shankland, S. W. McCuskey, F. C. Leone and G. Kuerit, "Analysis of the Interferometer Observations of Dayton C. Miller," *Reviews of Modern Physics*, 27(2):167-178, April, 1955.

heat added to the fringe shifts,⁷⁴¹ Shankland's team seized on these control experiments and used them against Miller, declaring that they "might" have affected his overall results. As DeMeo reports:

...the Shankland team...selected only those data sets which appeared to support their argument of a claimed thermal anomaly...leaving one to wonder if the unselected and excluded data, which constituted the overwhelming majority of it, simply could not provide support for their criticisms....For the casual reader, who had not undertaken a careful review of Miller's original experiments, the Shankland paper might appear to make a reasoned argument. However, the Shankland paper basically obfuscated and concealed from the reader most of the central facts about what Miller actually did, and in any case was so unsystematic and biased in its approach, excluding from discussion perhaps 90% or more of Miller's extensive Mt. Wilson data, as to render its conclusions meaningless....From all the above, it appears the Shankland group, with some degree of consultation with Einstein, decided that "Miller must be wrong" and then set about to see what they could find in his archive that would support that conclusion — which is not a scientific method.⁷⁴²

⁷⁴¹ Miller wrote: "Inequalities in the temperature of the room caused a slow, but steady, drifting of the fringe system to one side, but caused no periodic displacements....When the heaters were directed to the air in the light-path which had a covering of glass, a periodic effect could be obtained only when the glass was partly covered with opaque material in a very nonsymmetrical manner....These experiments proved that under the conditions of actual observation, the periodic displacements could not possibly be produced by temperature effects" ("The Ether-Drift Experiment and the Determination of the Absolute Motion of the Earth," *Reviews of Modern Physics*, vol. 5 (2), July 1933, p. 220). Unfortunately, historians such as Gerald Holton, otherwise very thorough in their research, turn a blind eye to certain results — as does Holton toward Shankland's miscues. Holton writes: "Again, on 14 March 1926, in a letter to A. Piccard, Einstein wrote, 'I believe that in the case of Miller, the whole spook is caused by temperature influences (air).' As it turned out, Einstein's intuitive response was right" (*Thematic Origins of Scientific Thought*, p. 335). This is not surprising to find in Holton's treatise on Einstein, since he rarely, if ever, faults Einstein with any bad motives or faulty reasoning.

⁷⁴² "Dayton Miller's Ether-Drift Experiments: A Fresh Look," pp. 23-25. DeMeo provides excruciating detail and expert commentary on the Shankland review of Miller's work. He concludes: "My review of this important but sad chapter in the history of science left me both astonished and frustrated. Miller's works on ether drift was clearly undertaken with more precision, care and diligence than any other researcher who took up the question, including Michelson, and yet, his work has basically been written out of the history of science. When alive, Miller responded concisely to his critics, and demonstrated the ether-drift phenomenon with increasing precision over the years. He constantly pointed out to his critics the specific reasons why he was getting larger positive results, while others got only small results, or no results. Michelson and a few others of the period took Miller's work seriously, but Einstein and his followers appeared to view Miller only as a threat, something to be 'explained away' as expeditiously as possible. Einstein in fact was catapulted into the

The only redeeming quality of the Shankland report is that within its own pages it registered some reserve regarding its own conclusions. As Consoli and Costanzo report:

public eye following the end of World War II. Nuclear physics was then viewed as heroic, and Einstein fast became a cultural icon whose work could not be criticized. Into this situation came the Shankland team, with the apparent mission to nail the lid down on Miller's coffin. The Shankland conclusions against Miller were clearly negative, but the one systematic statistical analysis of his Mt. Wilson data merely confirmed what Miller said all along, that there was a clear and systematic periodic effect in the interferometer data. The Shankland paper also confirmed Miller's contention that this periodic effect was *not the product of random errors or mechanical effects*. The Shankland team subsequently searched for temperature artifacts in Miller's data, but failed to undertake any systematic analysis of his centrally-important Mt. Wilson data in this regard. Instead, they made a biased selections of a few published and unpublished data sets obtained from different periods in Miller's research, from different experimental locations, including [those] from his control experiments at Case School...Miller's most conclusive 1925-26 Mt. Wilson experiments encompassed a total of 6,402 turns of the interferometer, recorded on over 300 individual data sheets. That was the data the Shankland team should have been focused upon and evaluated systematically. Instead, only a few of Miller's data sheets from these most centrally-important experiments were selected — certainly less than 10% of the data available to them was brought into discussion — and then only after being firstly dissected to extract only those data which could most easily be misconstrued as evidence for presumed temperature anomalies. For certain, some of the data held up for public critique came from Miller's control experiments at Case, or possibly from trial runs when technical 'bugs' were being worked out in the apparatus and building. Miller is no longer alive to inform us about his data, but the Shankland team willy-nilly lumped together both published and unpublished data, without comment....The Shankland group undertook no new experiments of their own, neither on the question of ether-drift, nor on the subject of thermal perturbations of light-beam interferometry — they made essentially an 'armchair analysis' of Miller's data. Only *some* of Miller's original data was carefully selected to make a rather unbelievable claim that small natural ambient temperature gradients in Miller's Mt. Wilson observation hut *might* produce fringe shifts in the insulated interferometer similar to what Miller himself previously observed in his control experiments using strong radiant heaters. The Shankland paper argued there *must have been* 'thermal effects' in Miller's Mt. Wilson measurements, but provides no direct evidence of this. *At no time did the Shankland group present evidence that temperature was a factor in creating the periodic sidereal fringe shifts observed by Miller in his published data, even though this was their stated conclusion.* In fact, they presented evidence from Miller's own lab notebooks which implied thermal gradients in the Mt. Wilson interferometer house would have been *below the observational limits* of the insulated apparatus....The fact that the present-day situation is totally [the] opposite of my example is a testament to the intensely political nature of modern science, and how major theories often develop into *belief-systems*, which demand the automatic suppression of any new finding which might undermine the faith and 'popular wisdom' of politically-dominant groups of academics. And that 'wisdom' today is: *Space is empty and immobile, and the universe is dead.* I submit, these are unproven, and even *disproven* assertions, challenged in large measure by Dayton Miller's exceptional work on the ether drift." NB: we emphasize here that, although DeMeo may have his own biased reasons for bringing the Shankland/Miller controversy to light (e.g., his work with Orgone Labs), nevertheless, the facts of the case remain what they are.

Within the paper the same authors [the Shankland team] say that “there can be little doubt that statistical fluctuations alone cannot account for the periodic fringe shifts observed by Miller.” In fact, although “there is obviously considerable scatter in the data at each azimuth position...the average values...show a marked second harmonic effect.”⁷⁴³

Added to this is the Shankland team’s admitted failure to establish a direct link between the appearance of second harmonic effects and thermal conditions. Consoli and Costanzo cite these words from the Shankland report:

“...we must admit that a direct and general quantitative correlation between amplitude and phase of the observed second harmonic on the one hand and the thermal conditions in the observation hut on the other hand could not be established.”⁷⁴⁴

Perhaps the Shankland team admitted to these facts in order to save themselves from any accusations of bias, but it is unfortunate that the admissions were completely overwhelmed by their general dismissal of Miller’s results. In any case, we only wish that Shankland had been as critical of the original Michelson-Morley experiment, or the dozens of others that supposedly found a “null” result in the interferometers. But not only did Shankland claim that the 1887 Michelson-Morley experiment had a “null” result, he asserted that all other such experiments yielded a null result. This simply was not true, as we have clearly seen in the case of Sagnac and Michelson-Gale, and others that will come to light.

Nevertheless, a preliminary report was sent to Einstein in August 1954, upon which Einstein replied with the following letter:

I thank you very much for sending me your careful study about the Miller experiments. Those experiments, conducted with so much care, merit, of course, a very careful statistical

⁷⁴³ M. Consoli and E. Costanzo, “The Motion of the Solar System and the Michelson-Morley Experiment,” Istituto Nazionale di Fisica Nucleare, Sezione di Catania Dipartimento di Fisica e Astronomia dell’ Università di Catania, November 26, 2003, p. 9, citing R. S. Shankland, et al., *Review of Modern Physics*, 27, 167, 1955, p. 171.

⁷⁴⁴ M. Consoli and E. Costanzo, “The Motion of the Solar System and the Michelson-Morley Experiment,” Istituto Nazionale di Fisica Nucleare, Sezione di Catania Dipartimento di Fisica e Astronomia dell’ Università di Catania, November 26, 2003, p. 9, citing R. S. Shankland, et al., *Review of Modern Physics*, 27, 167 (1955), p. 171, p. 175. Consoli and Costanzo compute the second harmonic component of the Michelson-Morley experiment to be: July 8, noon: 0.010 ± 0.005 ; July 9, noon: 0.015 ± 0.005 ; July 11, noon: 0.025 ± 0.005 ; July 8, evening: 0.014 ± 0.005 ; July 9, evening: 0.011 ± 0.005 ; July 12, evening: 0.018 ± 0.005 (*op cit.*, p. 15)

investigation. This is more so as the existence of a not trivial positive effect would affect very deeply the fundament of theoretical physics as it is presently accepted. You have shown convincingly that the observed effect is outside the range of accidental deviations and must, therefore, have a systematic cause [having] nothing to do with ‘ether wind,’ but with differences of temperature of the air traversed by the two light bundles which produce the bands of interference.⁷⁴⁵

We can see from the words “a not trivial positive effect would affect very deeply the fundament of theoretical physics as it is presently accepted” was precisely the same sentiment that Einstein voiced to Herbert Samuel a few years earlier: “If Michelson-Morley is wrong, then relativity is wrong.”⁷⁴⁶ A “trivial positive effect” was just what Miller found, but as we have seen above, all the other interferometer experiments, including Michelson-Morley, showed the same trivial positive results. As noted in his quote above, Miller claimed nothing more than what Michelson-Morley’s results already indicated.

Other evidence related to Shankland shows that Einstein was doing his best to ignore or even stifle experiments designed to show the same positive results as Michelson-Morley. In an interview Shankland arranged with Einstein in 1952, he asked Einstein about the recently published paper on Relativity by J. L. Synge who predicted a small positive effect in a Michelson-Morley-type experiment. Shankland reports:

⁷⁴⁵ Robert Shankland, “Conversations with Albert Einstein II,” *American Journal of Physics*, 41:895-901, July 1973. Cited in DeMeo, p. 3. Recently, Nobel laureate Maurice Allais has done extensive study of Miller’s results, and has concluded in his abstract: “It is utterly impossible to consider that the regularities displayed in Miller’s interferometric observations can be explained by temperature effects. As a result the light velocity is not invariant whatever its direction and consequently the principle of invariance of light velocity on which fundamentally does rest the special theory of relativity is invalidated by the observation data.” Allais adds: “Shankland’s and et al’s conclusions on the temperature effects are based on shaky hypotheses and reasonings. They are totally unfounded” (L’origine des régularités constatés dans les observations interférométriques de Dayton C. Miller (1925-1926): variations de température ou anisotropie de l’espace,” C. R. Academy of Science, Paris, t. 1, Série IV, p. 1205-1210, 2000, translated from the French, p. 1205). In addition to Allais, Reginald T. Cahill points out that the non-interferometer coaxial cable experiments of DeWitte (1991) and Torr and Kolen (1984) show results of motion equal to Miller’s 1925 data. In the midst of analyzing the results Cahill concludes: “So the effect is certainly cosmological and not associated with any daily thermal effects, which in any case would be very small as the cable is buried” (Novel Gravity Probe B Gravitational Wave Detection, Flinders University, August 21, 2004, pp. 16-17).

⁷⁴⁶ *Einstein: The Life and Times*, p. 107.

Einstein stated strongly that he felt Synge's approach could have no significance. He felt that even if Synge devised an experiment and found a positive result, this would be completely irrelevant....[Later] he again said that more experiments were not necessary, and results such as Synge might find would be 'irrelevant,' He told me not to do any experiments of this kind.⁷⁴⁷

The only thing Miller did was confirm the “trivial” results of Michelson-Morley by doing over 100,000 trials to the former's 36 trials, and by showing from which direction the ether drift originated. The fact that Einstein thought Miller's results denied his Relativity theory but that Michelson-Morley's results supported it, tells us that something was seriously wrong with either the information being disseminated about the interferometer experiments, or, more likely, that scientists were so biased in interpreting those results in their presumed favor (i.e., as “null” results), that the whole world was convinced by some strange pixie dust that what was actually black was now white. Men do such things when the evidence gets uncomfortably close to revealing the truth about the cosmos as it really is, and as the Bible itself predicts. The Psalmist tells us that “the heavens declare the glory of God, and the firmament shows his handiwork” but modern science systematically suppresses it. As St. Paul says, “...the unrighteousness of men *who suppress the truth*...because that which is known about God is evident among them, for God made it evident to them.”⁷⁴⁸ It is the same kind of suppression we saw with Edwin Hubble and Stephen Hawking who, after seeing evidence that Earth was in the center of the universe, declared it “intolerable” and concocted other theories to explain it away, feigning humility in the process. At the least, the world should have been told that there was a significant possibility that the Earth wasn't moving. That would have been a fair and scientific way of handling the evidence. In fact, acquiescing to Miller would have allowed science to opt for a moving Earth against a stationary ether as at least one of the possible solutions of his experimental results, for that is what Miller himself surely proposed.⁷⁴⁹ But modern physics was so bent on protecting

⁷⁴⁷ R. S. Shankland, “Conversations with Albert Einstein,” *American Journal of Physics*, 31:47-57, 1963, pp. 53-54, cited in *Thematic Origins of Scientific Thought*, p. 366. Holton says that “an experiment along these lines was devised later and gave a null result, as Einstein had predicted,” but he gives no reference to any such experiment and thus we do not know what Holton understands as “null,” considering that Synge claimed to predict “a small positive effect,” which is precisely what Miller's experiments found, and what the original Michelson-Morley experiment found (3-4 km/sec, not 0).

⁷⁴⁸ First quote is from Psalm 19:1 [18:1], the second from Romans 1:18-19, author's translation.

⁷⁴⁹ As we noted earlier, however, Miller's results did not prove that the Earth was moving through ether, since the equally viable explanation is that the ether is moving

Einstein that they couldn't see the forest for the trees. As a result, they perpetuated a misinterpretation of Michelson-Morley to save themselves, so they thought, from having to reveal the news that the Earth may not be moving at all. That news, of course, would have been almost as devastating to mankind as the return of Christ himself at the end of the world, for surely it would have been the death-knell to the runaway train of pseudo-intellectualism that pervades the modern age.

Interestingly enough, Miller's evidence against Einstein was corroborated from an unlikely source, Albert Michelson himself. In 1926-1929, Michelson, with Francis Pease and Fred Pearson, made several attempts at repeating the 1887 Michelson-Morley experiment. Perhaps the results of the 1925 experiment that Michelson performed with Henry Gale a year earlier were too perplexing for him since, as we noted earlier, it produced the same positive results that Michelson should have recognized in 1887. Their 1929 paper, "Repetition of the Michelson-Morley Experiment," reported on three attempts to produce fringe shifts, using light-beam interferometry similar to that originally employed in the Michelson-Morley experiments. The first experiment, which used the same 22-meter light path as the original Michelson-Morley experiment, predicted a fringe shift of 0.017 but stated "no displacement of this order was observed." The second experiment in 1927 used a 32-meter light path and again stated: "no displacement of the order anticipated was obtained." Here we notice that, rather than report that he obtained a small positive result, Michelson obfuscates his results and claims only that they didn't produce what was "anticipated." On what he based his "anticipated" results is not stated, but perhaps it

against the motionless Earth due to the rotation of the universe, which carries the ether around Earth. Miller would have no way to prove which was correct. Miller claimed that, due to the combined movement of the sun and the Earth, the drifts accumulative effect was to make the Earth drift, in the final analysis, toward the southern hemisphere rather than equatorially. In the geocentric system, the precession or wobble of the universe's movement will likewise not allow a mere equatorial-based drift, at least during most of the year. In fact, we can predict that the ether drift should change direction depending on where the universe is in its annual precession. Miller's data correlates with this. During the latter stages of his experimental career, 1925 gave him the most optimal equipment and conditions to make his tests. In that year, Miller made four tests at four different times of the year. Each instance showed a different angle of displacement: February 8 was 10 degrees west, April 1 was 40 degrees east, August 1 was 10 degrees east, and September 15 was 55 degrees east. Here we see, for example, that between the sixth month interval of February 8 and August 1, the angle of displacement was precisely opposite (i.e., 10 degrees west versus 10 degrees east), showing the same difference as we see between the Earth's axis and Polaris in six-month intervals. In viewing Miller's hodographs of the ether drift, superimposing the universe on the hodograph, one can readily see how it oscillates back and forth twice per year. Hence it is no coincidence that the mean displacement of Miller's four months of figures is 23.75 degrees east of north which, in the geocentric system, equates with the precessional tilt of the universe, and in the heliocentric system with the tilt of the Earth's axis at 23.5 degrees.

was what he learned from the Michelson-Gale experiment just a couple of years earlier.

A third experiment performed in 1928 was moved to a “well-sheltered basement room of the Mount Wilson laboratory,” and this time the light path was increased to 52 meters, more than double the original 1887 experiment. This higher altitude and longer light-path came closer to Miller’s specifications. Thus, it is no surprise that, in this third try, Michelson indeed found significant fringe shifting, obviously because he finally learned to use better equipment. The more accurate equipment, however, brought out Michelson’s bias toward replicating the exact results of his 1887 experiment, since he makes a concerted effort to downplay the results of this third and final experiment. Perhaps Michelson, now that his name was a household word among physicists, realized how much the world depended on verifying his 1887 “null” results to save Relativity from the jaws of defeat. Even his daughter, Dorothy Michelson Livingston, knew what was at stake for the Albert Michelson legacy. Concerning Dayton Miller’s positive interferometer results she adds this bit of misplaced sarcasm: “Miller might have been wiser to have concentrated on his valuable research in acoustics and the exquisite tone of his flutes.”⁷⁵⁰

Regarding his interpretation of the 1928 experiments, Michelson downplays them with these words:

The results gave no displacement as great as one-fifteenth of that to be expected on the supposition of an effect due to a motion of the solar system of three hundred kilometers per second. These results are differences between the displacements observed at maximum and minimum at sidereal times, the directions corresponding to...calculations of the supposed velocity of the solar system. A supplementary series of observations made in directions half-way between gave similar results.⁷⁵¹

We see that Michelson did the same thing with his results that we saw Kennedy and Thorndike do with their results: contrast them to the presumed high velocities of celestial bodies in order to make the interferometer results look smaller. In the case of Kennedy-Thorndike, the nebulae [the term for galaxies in those days] were the contrast, whereas with Michelson-Pease-Pearson it is the solar system. There is a certain irony in this, since it is the heliocentric system that these men held as a fact that led them to hypothesize the high velocities of the

⁷⁵⁰ *The Master of Light: A Biography of Albert A. Michelson*, p. 315.

⁷⁵¹ “Repetition of the Michelson-Morley Experiment,” *Nature*, 123:88, 19 Jan. 1929; and in *Journal of the Optical Society of America*, 18:181, 1929, cited in DeMeo, p. 17.

nebulae and solar system in the first place.⁷⁵² In any case, Kennedy-Thorndike found a value of “ 10 ± 10 km per sec” for the ether’s resistance against the Earth. Lo and behold, Michelson found the same thing since, if one multiplies his “three hundred kilometers per second” by “one-fifteenth,” the result is 20 km/sec, which is precisely within Kennedy-Thorndike’s margin of error.⁷⁵³

Of course, none of this was a surprise to Miller. In commenting on Michelson’s results, the unassuming Miller only wished his colleague had been a little more astute and not done his experiment in a basement. He writes:

If the question of an entrained ether is involved in the investigation, it would seem that such massive and opaque shielding is not justifiable. The experiment is designed to detect a very minute effect on the velocity of light, to be impressed upon the light through the ether itself, and it would seem to be essential that there should be the least possible obstruction between the free ether and the light path in the interferometer.⁷⁵⁴

As Miller is not at all reluctant to point out precisely what Michelson-Pease-Pearson had demonstrated in their last ditch efforts to support Relativity theory, namely, that “The experiment is designed to detect a very minute effect on the velocity of light,” once again this brings us right back to the statement that Einstein made to Sir Herbert Samuel in Jerusalem: “If Michelson-Morley is wrong, then relativity is wrong.”⁷⁵⁵ The irony of the whole thing is that it was Albert Michelson himself who proved that Michelson-Morley was wrong. In fact, Michelson proved this in two ways. The first was by the Michelson-Gale experiment in 1925 that measured the same absolute motion that Sagnac discovered in 1913; the second, by the Michelson-Pease-Pearson experiment which showed an ether drift against the Earth, and that the speed of light was affected by it. But since he was too blinded by whatever was prohibiting him from telling the whole truth, Michelson

⁷⁵² In the geocentric system, the celestial bodies are not traveling at high velocities since, as they are embedded in the universal ether, it is the ether that does the rotating around the Earth, with only slight independent movement of the celestial bodies within the ether. It is precisely the rotation of the ether every 24 hours that accounts for the small positive results of all the interferometer experiments at the surface of the Earth.

⁷⁵³ Some commentaries say the multiplier was one-fiftieth as opposed to one-fifteenth, but the former appears to be in error.

⁷⁵⁴ “The Ether-Drift Experiment and the Determination of the Absolute Motion of the Earth,” *Reviews of Modern Physics*, vol. 5 (2), pp. 203-242, July 1933, cited in DeMeo, p. 18.

⁷⁵⁵ *Einstein: The Life and Times*, p. 107.

went to his grave thinking he had been successful, and so did the rest of the world. Miller's work was buried along with him.

Recent Ether-Drift Experiments Showing Positive Results

One of the most detailed and well-reasoned reports concerning ether-drift experiments comes from the Ukrainian scientists Yuri Galaev. He reveals the flaws and foibles of all previous experiments. In his work, *Ethereal Wind in Experience of Millimetric Radiowave Propagation*, he writes in his abstract (translation corrected):

The experimental hypothesis checks [for] the existence of such a material medium of a radiowave's propagation...as ether is propagated in [an] eight millimeter radiowave range. The ethereal wind speed and this speed's vertical gradient near the Earth's surface have been measured. The systematic measurement results do not contradict the initial hypothesis rules, and can be considered as experimental...confirmation about the ether's existence as a material medium in nature.⁷⁵⁶

The body of the paper reports the following (translation corrected):

The great work of collecting and analysis, dedicated to the ethereal wind problem, was performed by Atsukovsky. The ether model is offered and the ether dynamic picture of the world was designed in his works. The ether is represented as a material medium, which fills in the global space and has the properties of viscous and compressible gas; it is the building stuff of all material formations. The element of ether is an amer. The physical fields represent different forms of ether motion, i.e., the ether is [the] material medium for electromagnetic wave propagation. The gradient boundary layer is formed at [the] mutual motion of the solar system and ether near the Earth's surface, in which the ether running speed (ethereal wind) increases with the altitude. The ethereal wind apex is northern." To account for previous "null" results of modern experimentation he adds: "It is shown that metals have larger etheric dynamic resistance and interfere with the ether flows. Therefore, metering devices arranged in metal chambers is inadmissible. The work authors consider that the experiments are authentic"⁷⁵⁷

In other words, those who found a "null" result mistakenly thought their experiments were accurate, but they never considered how

⁷⁵⁶ "Ethereal Wind in Experience of Millimetric Radiowave Propagation," *Spacetime and Substance*, Vol. 2, No. 5 (10), 2001, p. 211.

⁷⁵⁷ "Ethereal Wind in Experience of Millimetric Radiowave Propagation," *Spacetime and Substance*, Vol. 2, No. 5 (10), 2001, pp. 212-213.

the metal casing was shielding the ether. Galaev faults Miller's experiments for a different reason. He writes (translation corrected):

...Miller's huge interferometer was disassembled [and] assembled again and adjusted while moving from Cleveland to Mt. Wilson observatory. Therefore, the technique, which Miller applied for speed-dependence measurement of the discovered motion from an altitude above the Earth's surface, was unacceptable to make a final conclusion for the benefit of ether's existence.⁷⁵⁸

Galaev is probably right about the disassembling/assembling issue. Galaev's radiowave tests, which he outlines in excruciating mathematical and physical detail in his paper, were performed over five months, from September 1998 until January 1999. Measurements were taken round the clock, except on certain days, for a total of 1288 hours. In the final analysis, his findings confirm Miller's 1925 and Michelson's 1929 results. He writes:

The obtained value...8,490 m/sec...is close to the result of 9,000 m/sec [of Miller]. A bit smaller value...in comparison [with Miller] can be explained due to the...slightly cross terrain. Miller built a light wooden house...with windows made of white canvas on all its sides. In 1929 Michelson, Pease, Pearson conducted a similar experiment in a fundamental building of an optical workshop...The ethereal wind measured speed was no more than 6,000 m/sec as a result.⁷⁵⁹

He concludes (translation corrected):

The executed analysis has shown that these results can be explained by radiowaves-propagation phenomenon in a space parentage-driving medium with a gradient layer speed in this medium flow near the Earth's surface. The gradient layer available testifies that this medium has the viscosity – the property of intrinsic material medium, i.e., material consisting of separate particles. Thus the executed experimental results agree with the initial hypothesis positions about the ether material medium's existence in nature.⁷⁶⁰

⁷⁵⁸ "Ethereal Wind in Experience of Millimetric Radiowave Propagation," *Spacetime and Substance*, Vol. 2, No. 5 (10), 2001, p. 213.

⁷⁵⁹ "Ethereal Wind in Experience of Millimetric Radiowave Propagation," *Spacetime and Substance*, Vol. 2, No. 5 (10), 2001, p. 224. Galaev's 6,000 m/sec for Michelson is due to his using 1/50th instead of 1/15th of the 300 km/sec for the anticipated solar system movement.

⁷⁶⁰ "Ethereal Wind in Experience of Millimetric Radiowave Propagation," *Spacetime and Substance*, Vol. 2, No. 5 (10), 2001, p. 213. See also Yuri M. Galaev, "Ether-drift.

Galaev's remark that the ether has "viscosity" and "consists of separate particles" is precisely what we would expect for a medium to propagate waves. This is precisely what fellow Ukrainian, N. A. Zhuck found as well.⁷⁶¹

Another prominent experimenter and interpreter of these issues is Nobel laureate Maurice Allais. Allais wrote four papers on the results of Dayton Miller's work, and although he agreed with the results of the work, he added a different interpretation, namely, there is an optical anisotropy in space; and the cosmic velocity is towards Hercules, not Draco.⁷⁶²

Experiment in the band of radio wave," Petit, Zhukovsky, 2000 (Russian); "Ether-drift effects in the experiments on radio wave propagation," (*Radiophysics and Electronics*, Institute for Radiophysics and Electronics of the National Academy of Sciences of Ukraine, Vol. 5, No. 1, pp. 119-132, 2000 (in Ukrainian). See also "The Measuring of Ether-Drift Velocity and Kinematic Ether Viscosity Within Optical Waves Band," (*Spacetime and Substance*, Vol. 3, No. 5 (15), 2002, pp. 207-224).

⁷⁶¹ "The equation $d^2 X/dt^2 + H dx/dt = 0$ shows that the ether has viscosity. Also, it was shown that the bearer, [in] both gravitational and electromagnetic interactions, is the medium (ether) consisting of particles (amer) μ by a mass about 10-69 kg...taking into account the polarizability of an ether, i.e., the presence in it of elastic properties (that has been confirmed by [the] spread of a wavelike process as electromagnetic waves) in the obtained equation it is necessary to add one more item $\mu\omega_0^2 X$ named the recovery force (here ω_0 is the ether particles oscillations eigenfrequency). Zhuck, p. 208. See also N. A. Zhuck in "Cosmological Effects in Bulky Michelson-Morley Interferometers," (Ukrainian-Russian conference, Nov. 8-11, 2000, Abstracts, p. 73); and in *Spacetime and Substance* 1:5, 71-77 (2000), in Russian.

⁷⁶² "The Experiments of Dayton C. Miller (1925-1926) And the Theory of Relativity" in 21st Century, Science and Technology, Spring 1998, p. 31; Maurice Allais, "Des régularités très significatives dans les observations interférométriques de Dayton C. Miller (1925-1926) C. R. Academy of Science, Paris, t. 327, Série II b, p. 1405-1410, 1999; "Nouvelles régularités très significatives dans les observations interférométriques de Dayton C. Miller (1925-1926)" C. R. Academy of Science, Paris, t. 327, Série II b, p. 1411-1419, 1999); L'origine des régularités constatés dans les observations interférométriques de Dayton C. Miller (1925-1926): variations de temperature ou anisotropie de l'espace," C. R. Academy of Science, Paris, t. 1, Série IV, p. 1205-1210, 2000). Allais was also noted for showing evidence of displacements in pendulums during solar eclipses (Chris Duif, "A Review of Conventional Explanations of Anomalous Observations during Solar Eclipses," in *Journal of Scientific Explanation* by Peter A Sturrock, 19:327, 2005).

Joshua the son of Nun was mighty in war, and was the
successor of Moses in prophesying. He became, in
accordance with his name, a great savior of God's elect,
to take vengeance on the enemies that rose against them,
so that he might give Israel its inheritance.

How glorious he was when he lifted his hands and
stretched out his sword against the cities!
Who before him ever stood so firm? For he waged the
wars of the Lord.

Was not the sun held back by his hand? And did not one
day become as long as two?

He called upon the Most High, the Mighty One, when
enemies pressed him on every side,
and the great Lord answered him with hailstones of
mighty power.

Sirach 46:1-6

"Equations, however impressive and complex, can arrive at the truth if the initial assumptions are incorrect."

Arthur C. Clarke⁷⁶³

"Something unknown is doing we don't know what - that is what our theory amounts to"

Arthur Eddington⁷⁶⁴

"The Lord God is subtle, but malicious he is not."

Albert Einstein⁷⁶⁵

"I have second thoughts. Maybe God is malicious."

Albert Einstein⁷⁶⁶

⁷⁶³ Arthur C. Clarke, *Profiles of the Future: An Inquiry into the Limits of the Possible*, New York: Holt, Rinehart and Winston, 1963, 1984, p. 21.

⁷⁶⁴ Sir Arthur Eddington, *The Nature of the Physical World*, from the 1927 Gifford Lectures at the University of Edinburgh, Cambridge University Press, 1929, p. 291.

⁷⁶⁵ Originally said to Princeton University mathematics professor Oscar Veblen, May 1921, upon hearing that an experimental result by Dayton C. Miller would contradict his theory of gravitation. Cited in *The Expanded Quotable Einstein*, p. 241.

⁷⁶⁶ To Valentine Bargmann. Quoted in Sayen's *Einstein in America*, p. 51, cited in *The Expanded Quotable Einstein*, p. 241.

Chapter 7

What is Space?

The Philosophical Problem of Extension and Divisibility

Perhaps the main question that has occupied science since the time of Descartes (who understood space as filled with whirlpools of force he called “vortices”) is whether space is composed of a substance, and if so, what is it? One of the reasons the question of ether keeps coming to the forefront stems from our basic knowledge that in order for something to be transferred from one place to another it must travel through the space between the two places. Whether it is light, electricity, magnetism, gravity, sound or material objects, it seems that all physical things must travel through a medium. At least everyone thought so up until the time of Einstein’s Special Relativity theory. Logically, if there is nothing between points separated by a distance, what difference should the distance make? More of nothing is still nothing. Einstein said light always traveled at a constant speed in a vacuum, but if light travels a certain distance of “nothing” between source and receiver, where was the light before it reached the receiver? Does space know place? Does not even relative motion presume there is at least one place of absolute rest?

The issue of what constitutes space is not only a science question but also a philosophical question. If, for example, we employ the services of a strong vacuum pump and eliminate all the air out of a container, do we now conclude there is “nothing” in the container? Philosophically speaking, how can “nothing” exist? Since the container hasn’t collapsed, our intuition tells us that the container is still taking up space, even though there is, presumably, “nothing” inside of it. Incidentally, one cannot argue that, due to the inefficiency of vacuum pumps, there may be at least some molecules of air left in the container. Even if that were the case, the molecules, sparse as they would be, would be separated by vast spaces between them, so the question remains: what constitutes the space between the few remaining molecules in the container? As one modern physicist answered the question: “But what we’ve learned is...if you take everything away, there’s still something there.”⁷⁶⁷ Or as another physicist put it:

⁷⁶⁷ Lawrence M. Krauss, “Questions That Plague Physics,” *Scientific American*, Sept. 2004, p. 83. Krauss, chairman of the physics department at Case Western Reserve University, is, however, an outspoken critic of String Theory and Quantum Loop Gravity, as outlined in his books: *Hiding in the Mirror: The Mysterious Allure of Extra Dimensions*. He is also an advocate of keeping Creation science out of the public schools.

We can no longer sustain the simple idea that a vacuum is just an empty box. If we could say that there were no particles in a box, that it was completely empty of all mass and energy, then we would have to violate the Uncertainty Principle because we would require perfect information about motion at every point and about the energy of the system at a given instant of time...⁷⁶⁸

True enough. Science is at a loss to tell us what a vacuum really is. We see this in other phenomena as well. Ever since the time of Ernest Rutherford (1871-1937), science has settled upon the idea that the atom itself is composed of mostly empty space between the electrons whizzing around the protons and neutrons. Under current theory, only a quadrillionth of the atom is occupied by the atom's particles. But isn't the "empty space" of the atom the same as the "nothing" left in the container by the vacuum pump?

For the sake of argument, let's posit that there is a substance much smaller than the electrons and protons that fits compactly between them. The grains of this substance must then be smaller than any of the numerous subatomic particles man has discovered, including neutrinos, muons, gluons, mesons, kaons, etc. Let's say that this infinitesimally small substance also fills the space of the "nothing" left in our vacuum container, so that we can now say that there is "something" still in the container, although we can neither see it nor possess instruments capable of detecting it. This was precisely the thinking of scientists from Descartes to Lorentz. They knew instinctively that some kind of medium had to exist, at least on a theoretical basis, even if they couldn't detect it. While Newton resolved in his 1687 book *Principia Mathematica* that "I design only to give mathematical notion of these forces, without consideration of their physical causes and seats," which led to his concept of "action-at-a-distance" whereby gravity was mysteriously transported over vast distances by some mysterious yet unexplained means, he believed, nevertheless, that space was filled with something. He writes:

May not planets and comets, and all gross bodies, perform their motions more freely, and with less resistance in this aethereal medium than in any fluid, which fills all space adequately without leaving any pores, and by consequence is much denser than quick-silver and gold? And may not its resistance be so small, as to be inconsiderable? For instance; if this aether (for so I will call it) should be supposed 700,000 times more elastick than our air, and above 700,000 times more rare; its resistance would be above 600,000,000 times less than that of

⁷⁶⁸ John D. Barrow, *The Book of Nothing: Vacuums, Voids, and the Latest Ideas about the Origins of the Universe*, New York, Pantheon, 2000; Vintage Press, 2002, pp. 204-205.

water. And so small a resistance would scarce make any sensible alteration in the motions of the planets in ten thousand years.⁷⁶⁹

Others after him held closely to this conviction, since it explained so many other phenomena in nature. As Robert Hooke understood it:

The mass of æther is all æther, but the mass of gold, which we conceive, is not all gold; but there is an intermixture, and that vastly more than is commonly supposed, of æther with it; so that vacuity, as it is commonly thought, or erroneously supposed, is a more dense body than the gold as gold. But if we consider the whole content of the one with that of the other, within the same or equal quantity of expanation, then they are both equally containing the material or body.⁷⁷⁰

James Clerk Maxwell's entire electromagnetic theory was built on the foundation of ether, and he held the same idea as Newton regarding the constitution of interplanetary space. He writes:

Ether or Æther (αἰθήρ probably from αἶθω I burn) a material substance of a more subtle kind than visible bodies, supposed to exist in those parts of space which are apparently empty....Whatever difficulties we may have in forming a consistent idea of the constitution of the aether, there can be no doubt that the interplanetary and interstellar spaces are not empty, but are occupied by a material substance or body, which is certainly the largest, and probably the most uniform body of which we have any knowledge. Whether this vast homogeneous expanse of isotropic matter is fitted not only to be a medium of physical interaction between distant bodies, and to fulfill other physical functions of which, perhaps, we have as yet no conception, but also...to constitute the material organism of beings exercising functions of life and mind as high or higher than ours are at present - is a question far transcending the limits of physical speculation.⁷⁷¹

⁷⁶⁹ Isaac Newton, *Opticks*, Fourth edition, 1730, Question 22. Newton addresses the issue of ether from Questions 18-31, mostly in reference to the travel of light through ether.

⁷⁷⁰ *From the Posthumous Works of Robert Hooke*, 1705, pp. 171-172, cited in Oliver Lodge, *The Ether of Space*, p. 98.

⁷⁷¹ *Encyclopedia Britannica*, 9th edition, Edinburgh: Adam and Charles Black, 1875, under the title "Ether," republished by Cambridge University Press, 1890. Expanding on Maxwell's Greek, the word αἰθήρ commonly referred to the upper, purer air, as opposed to αἶρ, the lower air or atmosphere. This distinction would make the ether the rarified interplanetary medium in distinction to the air near the Earth. Although αἶθω may be the closest derivative, it was a separate word found only in the present and imperfect tense, ἠθον, meaning "to light or kindle," and rarely "to burn or blaze."

The vast interplanetary and interstellar regions will no longer be regarded as waste places in the universe, which the Creator has not seen fit to fill with the symbols of the manifold order of His kingdom. We shall find them to be already full of this wonderful medium; so full, that no human power can remove it from the smallest portion of space, or produce the slightest flaw in its infinite continuity. It extends unbroken from star to star; and when a molecule of hydrogen vibrates in the dog-star, the medium receives the impulses of these vibrations, and after carrying them in its immense bosom for several years, delivers them, in due course, regular order, and full tale, into the spectroscop of Mr. Huggins, at Tulse Hill.⁷⁷²

As we have noted in previous chapters, the scientists of this day found at least something resembling a medium in space in all their interferometer experiments of the late 1800s and into the 1900s. Regardless of how small, they measured some resistance to light traveling in a specific direction on the surface of the Earth. As we also noted, since that resistance was smaller than what they expected for an Earth supposedly revolving around the sun at 30 km/sec, the experimenters invariably produced erroneous or biased interpretations, which resulted in Einstein's hasty rejection of ether, and with that, the missed opportunity of finding a proper explanation for the small positive results afforded by actual experimental evidence.

But if space has substance, what is it? We know that, even though it is not seen, nevertheless, it impedes the light circling an interferometer. If it is smaller than an atom's components, how small can it be? Will it ever reach a point of being "indivisible"? This question introduces us to another philosophical problem – the problem of extension and divisibility. The fact that matter exists means that it extends into space. Descartes developed the Cartesian coordinates to help determine the exact "point" in space an object occupies.⁷⁷³ Although, on the one hand,

Another significant derivative is $\alpha\acute{\iota}\theta\omega\nu$, the participle of $\alpha\acute{\iota}\theta\omega$, which either means "fiery burning" or "flashing or glittering metal" (Liddell and Scott, *Greek-English Lexicon*, Oxford University Press, 1871, 1977, pp. 18-19). The "metal" aspect of ether has some representation in the Hebrew word רָקִיעַ translated as "firmament" in Genesis 1:6-9, since the Hebrew refers, among other meanings, to a beaten down metal, denoting the firmness of its constitution.

⁷⁷² *Encyclopedia Britannica*, 9th edition, Edinburgh: Adam and Charles Black, 1875, under the title "Ether," republished by Cambridge University Press, 1890, as cited in Sir Oliver Lodge, *The Ether of Space*, New York and London, Harper and Brothers, 1909, p. 114.

⁷⁷³ Descartes formulated the Cartesian coordinates by observing a fly flying in his room. He reasoned that the exact location of the fly in flight could be calculated at any one instant by measuring the distance the fly was from the floor and two adjacent sides of the room.

the concept of occupying space is very simple, on the other hand, the fact that something is extended means that it is divisible. A twelve-inch-long rod can be cut into two pieces of six inches, and a six-inch rod is divisible into two three-inch pieces, and so on and so on. Theoretically, we could divide the rod in half for an infinite number of times. We can divide the rod manually as well, but we may reach a point where, at least on a physical basis (not theoretical), we cannot divide the rod any longer.⁷⁷⁴ In other words, matter might reach a point where it is physically indivisible. The Greeks called this stage of indivisibility the “atom.” Of course, today, although we use the word “atom” to designate the relationship of electrons circling protons and neutrons, we know, or suspect, that the latter are made up of a dizzying array of even smaller particles. But just how small can nature be before it reaches its limit of physical divisibility? We may never know for certain, but we do have some parameters with which to work, which we will investigate momentarily.

⁷⁷⁴ Incidentally, this brings up the thorny issue concerning theoretical postulates formed from “thought experiments” as opposed to those formed from physical evidence found by experiment. Theoretical thought experiments may require causes and effects that are physically impossible to attain, and thus leave the hypotheses issuing from them as either false or unprovable. Conversely, although experimental evidence is the best means of physically verifying the truth, we may not possess the mechanical apparatus to determine whether a theoretical concept is true or false, as is the case with the Heisenberg Uncertainty Principle.

Einstein's Ether

Perhaps the best place to begin in discovering what constitutes space is to investigate the turn of events that took place in Albert Einstein's theorizing on the subject. This is an important starting point for the simple reason that, whereas from the years 1905-1915 Einstein had rejected the notion of ether filling the constitution of space, it was in the year 1916 that he re-adopted ether as a constituent part of his theory of General Relativity, although with extensive modifications to Lorentzian ether. In 1916 he wrote:

...in 1905 I was of the opinion that it was no longer allowed to speak about the ether in physics. This opinion, however, was too radical, as we will see later when we discuss the general theory of relativity. It does remain allowed, as always, to introduce a medium filling all space and to assume that the electromagnetic fields (and matter as well) are its states...once again "empty" space appears as endowed with physical properties, i.e., no longer as physically empty, as seemed to be the case according to special relativity. One can thus say that the ether is resurrected in the general theory of relativity...Since in the new theory, metric facts can no longer be separated from "true" physical facts, the concepts of "space" and "ether" merge together.⁷⁷⁵

It would have been more correct if I had limited myself, in my earlier publications, to emphasizing only the non-existence of an ether velocity, instead of arguing the total non-existence of the ether, for I can see that with the word *ether* we say nothing else than that space has to be viewed as a carrier of physical qualities.⁷⁷⁶

Prior to this shift, Einstein had made the following statements, five years apart, the first from his famous 1905 paper:

⁷⁷⁵ Albert Einstein, "Grundgedanken und Methoden der Relativitätstheorie in ihrer Entwicklung dargestellt," *Morgan Manuscript*, EA 2070, as cited in Ludwik Kostro, *Einstein and the Ether*, Apeiron, 2000, p. 2. For a good summation of Einstein's reasoning in regard to reviving the ether concept, see Galina Granek's "Einstein's Ether: Why Did Einstein Come Back to the Ether?" *Apeiron*, vol. 8, no. 3, July 2001; "Einstein's Ether: Rotational Motion of the Earth," *Apeiron*, vol. 8, no. 2, April 2001; Ludwik Kostro, "Einstein and the Ether," *Electronics and Wireless World*, 94:238-239 (1988). Kostro writes: "the notion of ether was not destroyed by Einstein, as the general public believes" (*ibid.*, p. 239); "Lorentz wrote a letter to Einstein in which he maintained that the general theory of relativity admits of a stationary ether hypothesis. In reply, Einstein introduced his new non-stationary ether hypothesis" (*ibid.*, p. 238).

⁷⁷⁶ Albert Einstein, "Letter to H. A. Lorentz, November 15, 1919," EA 16, 494, as cited in Ludwik Kostro, *Einstein and the Ether*, Apeiron, 2000, p. 2.

The introduction of a ‘light ether’ will prove to be superfluous, because the view here to be developed will introduce neither a ‘space at absolute rest’ provided with special properties, nor assign a velocity vector to a point of empty space in which electromagnetic processes take place.⁷⁷⁷

The second, in 1910, stated: “The first step to be made...is to renounce the ether.”⁷⁷⁸

So there we have it. What Special Relativity taketh away with the left hand, General Relativity giveth back with the right hand. Few are aware of this dramatic shift in Einstein’s thinking, and of those, many are embarrassed to admit that the ether concept had to be reintroduced and coincided with the very leg of the Relativity theory that had vociferously denied it. The reason? Previously to 1916, Einstein wanted to divest physics, entirely, of the notion of absolute rest. The concept of an immobile Earth or immobile ether was, for some odd reason, repugnant to him. Having already accepted Copernican cosmology,⁷⁷⁹ the ether was the last thing standing in his way. As he understood it, if ether existed, it necessitated that there be absolute space. If there is absolute space, then there is absolute rest. Obviously, Relativity cannot exist with anything being at absolute rest, for, by definition, the theory would be nullified.

The task of putting the nails into ether’s coffin was not so easy, however. Henri Poincaré left some unfinished business that Einstein still had to address. Poincaré continued to insist upon the existence of ether for three main reasons: (1) stellar aberration (which we covered previously in the study of the Arago and Airy experiments); (2) “action-at-a-distance” whereby gravity and electromagnetism could be transmitted over vast distances; (3) rotational motions (of which we saw an example in Sagnac’s 1913 experiment). Although Einstein felt that he had answered the phenomenon of stellar aberration (but, as we noted earlier, in reality he had not), he did not have a quick answer for rotation and action-at-a-distance.

In addition, Dayton Miller, as we have detailed earlier, was hot on Einstein’s trail between 1921 and 1933. With Miller’s new and improved interferometer experiments, Einstein could run but not hide

⁷⁷⁷ “Zur Elektrodynamik bewegter Körper,” *Annalen der Physik*, 4th series, 17, Sept. 26, 1905.

⁷⁷⁸ “Le Principe de relativité et ses consequences dans la physique moderne,” *Archives de sciences physiques et naturelles*, 29, pp. 18-19.

⁷⁷⁹ In 1938 Einstein wrote: “Since the time of Copernicus we have known that the Earth rotates on its axis and moves around the sun. Even this simple idea, so clear to everyone, was not left untouched by the advance of science. But let us leave this question for the time being and accept Copernicus’ point of view” (Albert Einstein and Leopold Infeld, *The Evolution of Physics*, New York, Simon and Shuster, 1938, 1966, pp. 154-155).

from the mounting evidence for the existence of ether. Along these same lines, in 1923 Ernst Gehrcke published the article “The Contradictions between the Ether Theory and Relativity Theory and Experimental Tests”⁷⁸⁰ in which he reexamined the Michelson-Morley, Michelson-Miller, and Georges Sagnac experiments, concluding that Relativity theory simply did not have a good explanation for the results.

In the late 1920s, Paul R. Heyl posed a different yet related question to Einstein:

...Einstein pointed out that there might be no such thing as gravitational force any more than there is a centrifugal force; that both may be considered as manifestations of inertia aided in the case of gravitation by curved space acting much like a mechanical surface of constraint. For this reason it is sometimes said that the theory of relativity has done away with the ether. I hardly think that is a fair statement...[I]f relativity ignores the ether, does it not introduce what is to all intents and purposes its equivalent? The ether was supposed to be a medium filling all space that otherwise would be empty. Einstein supposes space itself to be enough of an entity to have a curvature, and to be “empty” only where and when it is flat. But if space can be bent and can straighten out again, why can it not repeat this process with sufficient rapidity to be called a vibration? And what difference does it make whether it is space itself that vibrates, or something that fills space? Back in every one of our heads is the idea that there is something which philosophers call a “thing-in-itself” which is responsible for our sensations of light and electricity; and whether we spell it ETHER or SPACE, what does it matter?⁷⁸¹

Einstein was thus forced back to at least some concept of ether, but here is where he wanted it both ways. He needed ether to account for the physical effects of action-at-a-distance and rotational motion, but he did not want to give ether any physical attributes, for if he did, that would nullify Relativity theory. As he puts it:

The special theory of relativity forbids us to assume the ether to consist of particles observable through time, but the hypothesis of ether is itself not in conflict with the special theory of

⁷⁸⁰ German title: “Die Gegensätze zwischen der Äthertheorie und Relativitätstheorie und ihre experimentale Prüfung,” *ZfP*, 4, 1923, Nr. 9, pp. 292-299, cited in Kostro, p. 135.

⁷⁸¹ Paul R. Heyl, “The History and Present Status of the Physicist’s Concept of Light,” in “Proceedings of the Michelson Meeting of the Optical Society of America,” *Journal of the Optical Society of America*, vol. XVIII, March 1929, p. 191.

relativity. Only we must be on our guard against ascribing a state of motion to the ether.⁷⁸²

So, according to Einstein's wishes, we can have the "concept" of ether but we cannot have "particles" or "motion" of ether. In this way, Einstein allows himself to maintain the key to his Relativity theory (the denial of absolute space and rest), yet have at least a conceptual basis for understanding action-at-a-distance and rotational motion. Although he says this "conceptual" ether has no "particles" or "motion," we are then told in the next paragraph that it, nevertheless, has at least some physical qualities. He writes:

But on the other hand there is a weighty argument to be adduced in favor of the ether hypothesis. To deny the ether is ultimately to assume that empty space has no physical qualities whatsoever. The fundamental facts of mechanics do not harmonize with this view. For the mechanical behavior of a corporeal system hovering freely in empty space depends not only on relative position (distances) and relative velocities, but also on its state of rotation, which physically may be taken as a characteristic not appertaining to the system in itself. In order to be able to look upon the rotation of the system, at least formally, as something real, Newton objectivizes space. Since he classes his absolute space together with real things, for him rotation relative to an absolute space is also something real. Newton might no less well have called his absolute space "ether"; what is essential is merely that besides observable objects, another thing, which is not perceptible, must be looked upon as real, to enable acceleration or rotation to be looked upon as something real.⁷⁸³

Here Einstein is preparing us for his concept of ether by citing Newton's notion of space. Since Newton made no absolute claims to knowing the constitution of space or the cause of gravity, Einstein feels safe in appealing to Newton. Einstein needs to "objectivize" space in order to explain movement within it (e.g., rotation and action-at-a-distance), but other than his metrical tensor fields developed from the geometry of Minkowski and Reimann, he does not reveal what "physical qualities" he will eventually attribute to space.

Ludwik Kostro has done the most work in retracing Einstein's steps toward reviving the ether. In fact, Kostro reveals that up to our day no one had made a thorough report of Einstein's concept of the ether, stating that his is "the first comprehensive history of Einstein's concept

⁷⁸² May, 1920 Leyden address, para. 16.

⁷⁸³ *Ibid.*, para. 18.

of the ether.”⁷⁸⁴ Kostro points out, however, that, like many other innovations of science attributed to Einstein, this, too, was the product of someone prior to Einstein that he had read but to whom he did not give any credit. The German physicist Paul Drude had written about the concept in 1900 in his work *Handbook of Optics*. Drude allows ether “...if one understands by ether not a substance, but only space endowed with certain physical characteristics.”⁷⁸⁵ Kostro comments:

We know for sure...that Einstein read the...*Handbook of Optics*, because upon reading it he wrote a letter to the author in which he offered his comments on the book...Einstein must also have read Drude’s *Physics of the Ether Based on Electromagnetism*, which appeared in 1894....Similarities between expressions, and even identical ways they were used, offer proof that Einstein studied these works thoroughly. In his subsequent works Einstein would define the ether as “physical space endowed with physical attributes.”⁷⁸⁶

All in all, Einstein envisioned three different kinds of ether: one for the Special theory; one for the General theory; and one for his hoped-for Unified theory. The ether for the Special theory originated from Lorentz, but Einstein rejected it because Lorentz understood it as an immobile ether, identical to the concept held by the 1905 Nobel Prize winner Ph. Lenard,⁷⁸⁷ and reminiscent of the “absolute space” of Isaac Newton. The ether of General Relativity only had to incorporate gravity, thus Einstein had to develop another type of ether in order to unify gravity with electromagnetism, which led to embellishing Riemann’s geometry with what was known as “tele-parallelism” and six more tensor fields in addition to the ten already being used by General Relativity. Of course, this attempt brought Einstein to the end of his rope, and he began to see that the whole endeavor might be seriously flawed, as we noted previously in his private letters to Maurice Solovine and others. Despite

⁷⁸⁴ Ludwik Kostro, *Einstein and the Ether*, Aperion, 2000, p. 7. Kostro adds: “There do exist a number of articles outlining the history of this subject by the author of the present work [Kostro]. In works by other historians of physics which the author had been able to obtain, Einstein’s ether and its features are given a mere mention. Many documents presented or quoted in this work have never been published. The documentation I have drawn upon here has been collected by the library of the Museum of Science and Technology in Munich (Deutsches Museum) and in the Bayerische Staatsbibliothek in Munich” (*ibid*).

⁷⁸⁵ Ludwik Kostro, *Einstein and the Ether*, Aperion, 2000, p. 18.

⁷⁸⁶ Ludwik Kostro, *Einstein and the Ether*, Aperion, 2000, pp. 19-20.

⁷⁸⁷ Ph. Lenard, *Über Äther und Materie, Zweite, ausführlichere und mit Zusätzen versehene Auflage*, Heidelberg, C. Winters Universitätsbuchhandlung, 1911, cited in Kostro, p. 42.

his valiant attempts, Einstein simply could not find singularity-free equations to his General or Unified Field theory.⁷⁸⁸

The details of Einstein's thought process are of interest here. In 1916, Einstein was distancing himself from Ernst Mach's philosophy, although he would keep Mach's concept of the "distant masses" (stars) as providing the inertial frame of the universe and the inertial force of local phenomenon. (Mach maintained his belief in ether in order to have a medium to transport the force from the stars). By the time Einstein gave his University of Leyden address on May 5, 1920, he had been sufficiently influenced by Henrick Lorentz's ether-based electromagnetic and cosmological views, and thus he admitted publically for the first time that the concept of ether was vital to physics, and, in fact, physics could not exist without it. First, Einstein reviews the various ether theories of the past. In the first half of the nineteenth century, Einstein understands that in the era of Fizeau and Fresnel:

...It appeared beyond question that light must be interpreted as a vibratory process in an elastic medium filling up universal space. It also seemed to be a necessary consequence of the fact that light is capable of polarization, that this medium, the ether, must be of the nature of a solid body, because transverse waves are not possible in a fluid, but only in a solid. Thus the physicists were bound to arrive at the theory of the "quasi-rigid" luminiferous ether, the parts of which can carry out no movements relative to one another except the small movements of deformation which correspond to light-waves.⁷⁸⁹

As for Maxwell and Hertz, Einstein said:

...the ether indeed still had properties which were purely mechanical, although of a much more complicated kind than the mechanical properties of tangible solid bodies. But neither Maxwell nor his followers succeeded in elaborating a mechanical model for the ether which might furnish a satisfactory mechanical interpretation of Maxwell's laws of the electro-magnetic field....Thus the purely mechanical view of nature was gradually abandoned. But this change led to a fundamental dualism which in the long-run was insupportable....This dualism still confronts us in unextenuated form in the theory of Hertz, where matter appears not only as

⁷⁸⁸ Kostro says that at one time Einstein arrived at a singularity-free theory by "removing the denominator from the equations." Quoting Einstein: "If one modifies the equations in an unessential manner so as to make them free from denominators, regular solutions can be obtained, provided one treats the physical space as consisting of two congruent sheets." Kostro also reveals that Einstein would eventually abandon this solution, however (*Einstein and the Ether*, pp. 138-140).

⁷⁸⁹ Lecture at the University of Leyden, Germany, May 5, 1920.

the bearer of velocities, kinetic energy and mechanical pressures, but also as the bearer of electromagnetic fields....The ether appears indistinguishable in its functions from ordinary matter. Within matter it takes part in the motion of matter and in empty space it has everywhere a velocity...⁷⁹⁰

This then leads to the theory of Lorentz. Einstein describes it as follows:

Such was the state of things when H. A. Lorentz entered upon the scene....He [took] from ether its mechanical, and from matter its electromagnetic, qualities. As in empty space, so too in the interior of material bodies, the ether, and not matter viewed atomistically, was exclusively the seat of electromagnetic field. According to Lorentz the elementary particles of matter alone are capable of carrying out movements; their electromagnetic activity is entirely confined to the carrying of electrical charges. Thus Lorentz succeeded in reducing all electromagnetic happenings to Maxwell's equations for free space. As to the mechanical nature of the Lorentzian ether, it may be said of it, in a somewhat playful spirit, that immobility is the only mechanical property of which it has not been deprived by H. A. Lorentz. It may be added that the whole change in the conception of the ether which the special theory of relativity brought about, consisted in taking away from the ether its last mechanical quality, namely, its immobility.

Next Einstein explains by means of his famous K and K' models what led him, initially, to dispense with ether.

The space-time and the kinematics of the special theory of relativity were modelled on the Maxwell-Lorentz theory of the electromagnetic field. This theory therefore satisfies the conditions of the special theory of relativity, but when viewed from the latter it acquires a novel aspect. For if K be a system of coordinates relative to which the Lorentzian ether is at rest, the Maxwell-Lorentz equations are valid primarily with reference to K. But by the special theory of relativity the same equations without any change of meaning also hold in relation to any new system of coordinates K' which is moving in uniform translation relative to K. Now comes the anxious question: Why must I in the theory distinguish the K system above all K' systems, which are physically equivalent to it in all respects, by assuming that the ether is at rest relative to the K system? For the theoretician such an asymmetry in the theoretical structure, with no corresponding asymmetry in the

⁷⁹⁰ *Ibid.* See also Arthur Miller's *Albert Einstein's Special Theory of Relativity* for an in-depth explanation of Hertz's contribution to the electromagnetic/ether issue, pp. 11-14.

system of experience, is intolerable. If we assume the ether to be at rest relative to K, but in motion relative to K', the physical equivalence of K and K' seems to me from the logical standpoint, not indeed downright incorrect, but nevertheless unacceptable.

What Einstein is trying to say is that, by accepting Special Relativity as a fact (which he believes has been proven by the Michelson-Morley experiment), then it must also be accepted that the “space-time and the kinematics of the Special Theory of Relativity” must hold for all objects and locations, whether at rest or in motion. Hence, it would be incorrect to make a distinction between one object and another by saying that one object is *at rest in ether* and the other is *moving in ether*, since, if both objects experience the same “space-time” effects regardless of their relationship to the ether, then the ether had nothing to do with what they experienced. For Einstein, ether not only becomes superfluous, it actually gets in the way of logic. Logic requires that if a substance such as ether exists, then it must produce different effects on an object at rest as opposed to an object in motion. Since there is no difference, in Einstein's logic one can then dispense with ether. Thus Einstein concludes:

The next position which it was possible to take up in face of this state of things appeared to be the following. The ether does not exist at all. The electromagnetic fields are not states of a medium, and are not bound down to any bearer, but they are independent realities which are not reducible to anything else, exactly like the atoms of ponderable matter.

Now, let us recall from previous analysis what led Einstein to this kind of thinking. The 1887 Michelson-Morley experiment, including its Fizeau-Fresnel precursors and its post-1887 confirmations, led Einstein and the rest of the world to believe that ether had no effect on objects because, as the experiments apparently proved, a light beam traveling with the Earth's velocity of 30 km/sec against the ether experienced no reduction in its speed when compared to a light beam that was not traveling against the ether. Rather than entertain the idea that the Earth was immobile, Einstein had two other alternatives: (a) that ether traveled with the Earth in its revolution around the sun; or (b) that there is no ether, and thus light itself is an absolute. Thus, the theory of Special Relativity was born, for if there is no ether, and all the heavenly bodies are in motion, then there is no absolute state of rest and no central point in the universe. Every object can act as its own inertial point. Each object will be subject to the same laws, and we, the observers, can understand how one object related to the next only by means of the equations of Relativity theory. Thus, if Special Relativity can explain the mathematical relationships of these various objects, then there is no need for an ether, or, for that matter, there is no need for any fixed absolute,

including a fixed Earth. Relativity makes the need for all absolutes superfluous. Accordingly, the confusing array of length contractions, time dilations, mass increases and gravitational warping seem much better ways of explaining the universe to the sophisticates of modern science than the simplified notion of a fixed Earth in a revolving sphere of stars.

Ph. Lenard was one of Einstein's most vocal opponents at this time. In a 1917 speech titled "Relativity Principle, Ether, Gravitation" he remarked that Einstein merely renamed ether as "space," and concluded that General Relativity theory could not exist without ether.⁷⁹¹ Einstein responded with "Dialogue Concerning Accusations against Relativity Theory" in 1918.⁷⁹² In it we find Einstein basing his ideas on the aforementioned misinterpretation of the Michelson-Morley experiment, saying such things as: "According to the special theory of relativity a privileged state of motion did not exist anymore; this meant the negation of ether in the sense of earlier theories," but he agreed with Lenard that the space of General Relativity had "physical properties." Ernst Gehrcke had already introduced a critique of Einstein with the article "On Critics and History of the New Theories of Gravitation" in 1916,⁷⁹³ and Paul Weyland followed with a 1920 paper titled "Einstein's Theory of Relativity as Scientific Mass Suggestion," concluding that "Einstein eliminated the ether by decree, [but] he re-introduced it via a different concept with the same functions."⁷⁹⁴

After Einstein's Leyden address in 1920 came the 1924 article titled *Über den Äther*. Einstein was on a quest to eliminate Lorentz's immobile ether and replace it with a pliable ether. He needed ether, at least in some form, to answer Newton's biggest problem: "action-at-a-distance." As he says in *Über den Äther*: "We are going to call this physical reality, which enters into Newton's law of motion alongside the observable ponderable bodies, the 'ether of mechanics.'"⁷⁹⁵ Einstein knew that there could be no such "action" unless there existed a continuous medium to carry it from one place to another. As he says in

⁷⁹¹ "Über Relativitätsprinzip, Äther, Gravitation," Leipzig, S. Hirzel, 1918, cited in Kostro.

⁷⁹² "Dialog über Einwände gegen die Relativitätstheorie," *Die Naturwissenschaften* 6, 1918, cited in Kostro.

⁷⁹³ "Zur Kritik und Geschichte der neueren Gravitationstheorien," *AdP*, 50, 1916, pp. 119-124, cited in Kostro. Gehrcke had also proved that Einstein plagiarized some of his work, specifically the 1898 mathematical work of Paul Gerber concerning the perihelion of Mercury (Kostro, *Einstein and the Ether*, p. 79).

⁷⁹⁴ "Einsteins Relativitätstheorie – eine wissenschaftliche Massensuggestion," *Tägliche Rundschau*, August 6, 1920, as cited in Kostro.

⁷⁹⁵ *Über den Äther*, p. 85, as cited in Kostro, *Einstein and the Ether*, p. 103.

the same work: “But every contiguous action theory presumes continuous fields, and therefore also the existence of an ‘ether.’”⁷⁹⁶ Since Einstein was convinced he could not have any object or place in the universe serve as an immobile point, this medium had to move. In Einstein’s theory, it would move because matter moved it, yet it would be continuous because matter permeates the universe. As he describes it:

No space and no portion of space [can be conceived of] without gravitational potentials; for these give it its metrical properties without which it is not thinkable at all....According to the general theory of relativity, space without ether is unthinkable; for in such space, not only would there be no propagation of light, but also no possibility of existence for standards of space and time (measuring rods and clocks), nor therefore any space-time intervals in the physical sense.⁷⁹⁷

One can easily see the strain under which Einstein had put himself. He desperately wanted the ether because it would give him “standards of space and time,” but he had not, and would never, as it develops, explain how he can possess such standards if both the matter and the ether it bends are constantly moving. Of course, we need only interject once again that, had Einstein properly interpreted the Michelson-Morley experiment, he would have had his “standard of space and time” in an immobile Earth.

Interestingly enough, at this point Einstein seems on the verge of resigning himself to failure. He even questions whether his Relativity theory is necessary, and, similar to Lorentz’s letter written to Einstein in 1915 seeking a

“‘world spirit,’ who would permeate the whole system under consideration without being tied to a particular place or ‘in whom’ the system would consist, and for whom it would be possible to ‘feel’ all events directly would obviously immediately single out one of the frames of reference over all others,”⁷⁹⁸

⁷⁹⁶ *Über den Äther*, p. 93, as cited in Kostro, *Einstein and the Ether*, p. 106. Also appearing in and translated from *Schweizerische naturforschende Gesellschaft, Verhandlungen*, 105, 1924, pp. 92-93, and also appearing in Einstein’s book, *The World as I See It*, New York, Covici Friede, 1934, “Relativity and the Ether,” 1920, pp. 121-137, cited from *The Einstein Myth*, Part 1, p. 100. Einstein would write many other papers on the ether, such as “The New Field Theory” in 1929; “The Problem of Space, Ether and Field as a Problem of Physics” in 1934.

⁷⁹⁷ *Äther und Relativitätstheorie*, Berlin, J. Springer, 1920, pp. 13-14, as cited in Kostro, *Einstein and the Ether*, pp. 97-98.

⁷⁹⁸ Henrick Lorentz to Albert Einstein, January 1915, Robert Schulmann, A. J. Kox, Michael Janssen and József Illy, editors, *The Collected Papers of Albert Einstein*,

Einstein surprisingly refers to God and His alternate choices in a 1926 letter to Sommerfield:

It is also necessary to criticize the fact that he [Eddington] often describes the theory of relativity as *logically* necessary. God could also have decided to create an absolute static ether instead of the relativistic ether. This would hold especially, if he were to adapt the ether to the (substantial) independence from matter, as in de Sitter, an opinion toward which Eddington obviously leans; because in such a case an “absolute” function should also be attributed to the ether.⁷⁹⁹

Correspondence 1914-1918. Princeton: Princeton University Press, 1998, Document 43.

⁷⁹⁹ Albert Einstein, “Letter to A. Sommerfield, 28/11/1926,” in *A. Einstein, A. Sommerfield Briefwechsel*, Basel-Stuttgart: Schwabe u. Co. Verlag, 1968, p. 109, as cited in Kostro, *Einstein and the Ether*, p. 99.

Concrete Candidates for Material Ether Carl Anderson's Discovery of the Positron

What science has found since the time of Einstein is a virtual sea of particles, both in the micro-levels and macro-levels of the cosmos, many of which are suitable candidates for the “ponderable” ether that Einstein dismissed because of his philosophical and scientific presuppositions. As noted above, the primary presupposition of which Einstein and all Copernican scientists were guilty is that they left no room to explain the interferometer experiments by means of a motionless Earth. Had they done so, it would have shown that something physical was there, even though they could not see, touch, hear, smell or taste it.

That this kind of presupposition would lead to either a misinterpretation of the evidence, or even a downright denial of it, was brought out quite clearly in Einstein's interpretation of [Carl Anderson's](#) experiment in 1932. Anderson (1905-1991) was an American physicist who, with Victor Francis Hess of Austria, won the Nobel Prize for physics in 1936 for his discovery of the positron, the first known particle of “antimatter.” In 1927, Anderson had begun studying X-ray photoelectrons (electrons ejected from atoms by interaction with high-energy photons). In 1930 he began research on gamma rays and cosmic rays. While studying photographs of cosmic rays in cloud-chambers, Anderson discovered a number of tracks whose orientation indicated they were caused by positively charged particles, but particles too small to be protons. In 1932 he announced that the particles were “positrons,” particles with the same mass as electrons but positively charged. Paul Dirac had predicted their existence in 1928. Anderson's claim was controversial until it was verified the next year by the British physicist Patrick M. S. Blackett.

Prior to Anderson, the electron was discovered in 1897 by J. J. Thomson; the proton in 1911 by Rutherford, Wein, et al., and the neutron in 1932 by James Chadwick. In 1937, Anderson would also discover the short-lived meson. Later came the discovery, although much of it theoretical, of about two hundred more nuclear particles, but most, like the meson, were unstable. The implications of Anderson's work, however, went far beyond the finding of just another subatomic particle. His discovery was another crossroads for science, perhaps equal to the 1887 Michelson-Morley experiment. As in 1887, everything depended on the *interpretation* given to the experiment. The wrong interpretation, which is inevitably based on the wrong presuppositions, would put all of science on the wrong track, and it could be decades, even centuries, before it would get back on the right track. As in the Michelson-Morley experiment, if science bases its interpretation on an unproven presupposition (e.g., that the Earth is moving at 30 km/sec), then every subsequent experiment, whether on the micro- or macro-level, will be

adversely affected, which has been the case with physics for quite a long time.

Carl Anderson's experiment was another example of such an occasion. In his discovery of the positron, Anderson found that when gamma radiation of no less than 1.022 million electron volts (MeV) was discharged in any point of space, an electron and positron emerged from that point.⁸⁰⁰ He also found the converse, that is, when an electron collides with a positron, the two particles disappear, as it were, and produce two gamma-ray quanta which disperse in opposite directions, but with a combined energy of 1.022 MeV. As one set of authors describe his discovery:

On August 2, 1932, Anderson obtained a stunningly clear photograph that shocked both men. Despite Millikan's protestations, a particle had indeed shot up like a Roman candle from the floor of the chamber, slipped through the plate, and fallen off to the left. From the size of the track, the degree of the curvature, and the amount of momentum lost, the particle's mass was obviously near to that of an electron. But the track curved the wrong way. The particle was positive. Neither electron, proton, or neutron, the track came from something that had never been discovered before. It was, in fact, a "hole," although Anderson did not realize it for a while. Anderson called the new particle a "positive electron," but positron was the name that stuck. Positrons were the new type of matter – antimatter – Dirac had been forced to predict by his theory. (The equation, he said later, had been smarter than he was.)⁸⁰¹

After the excitement of the discovery, of course, comes the interpretation. Often there is a vast gulf that separates the two. A viable interpretation of Anderson's discovery is that space is composed of a lattice of very stable electron-positron pairs which, when the proper quanta of radiation are administered, will either temporarily deform the lattice or jolt the electrons and positrons out of alignment and release them into the view of our bubble chambers. But there is one caveat for modern science: this particular interpretation contradicts both Einstein's theory of Relativity, which was well in vogue by 1932, and the Quantum Mechanical model of the atom known as the Standard Model. Since science almost invariably depends on the reigning paradigm to interpret new evidence (especially paradigms as strong as Relativity and Quantum Mechanics), a suitable counter-interpretation had to be created – one eliminating the possibility that space contained a material substance.

There were two men bold enough to apply this interpretation, Albert Einstein (to save Relativity) and Werner Heisenberg (to save

⁸⁰⁰ 1.022 MeV equals 3.9×10^{-19} calories.

⁸⁰¹ Robert Crease and Charles Mann, "Uncertainty and Complimentarity," *World Treasury of Physics, Astronomy and Mathematics*, ed., T. Ferris, 1991, p. 78.

Quantum Mechanics). Relativity theory holds that there is a physical relationship between energy and matter, as well as necessitating that space is a vacuum containing no “ponderable” ether. Thus Einstein had no choice but to conclude that the appearance and disappearance of the electron-positron pair was an example, as he called it, “of the creation and annihilation of matter.” Moreover, with the ability to create and destroy electrons and positrons, the formula $E = mc^2$ now had its first “proof.” Not only was there a mathematical relationship between matter and energy, but now there could be a relationship wherein energy could become mass, and mass could become energy. This became the standard interpretation of not only electrons and positrons, but of all subatomic particles that met their antimatter counterpart. Although this was pure speculation, these new interpretations did not seem to bother its authors. Let’s revisit one of our earlier authors, Jonathan Katz, as he explains the electron-positron “creation” in regard to gamma-ray bursts:

Einstein’s equation $E = mc^2$ gives the amount of energy E that can be obtained if a mass m is completely turned into energy. This relation can be turned around: if two gamma rays with total energy E collide, they may produce a mass m . However, this is only possible if particles whose masses are m or less can be *created* (visible light cannot turn into matter because there are no particles with small enough masses). The least massive known particles are electrons (negatively charged) and positrons (positively charged), each with a mass corresponding to 0.511 MeV of energy. Because electric charge is never created or destroyed, electrons and positrons can only be *created* in pairs, one of each, with zero total charge. Two gamma rays, each of energy 0.511 MeV or more, colliding head-on, can therefore *produce* an electron-positron pair. If the collision is not head-on, then the necessary energy is greater. If the gamma rays have more energy than the minimum required, the extra appears as kinetic energy of the *newborn* matter – the electron and positron are *born* in motion.⁸⁰²

As one can sense from reading Katz’s description, the science establishment has given this explanation so often, and believed it for so many years, they have not the slightest doubt or embarrassment in saying that matter is created out of thin air. As if hypnotized, they entertain no other possibilities. This is a perfect example of how the evidence from experiment will invariably be interpreted by the scientific paradigm reigning at the time, in this case, the theories of Relativity and the Quantum Model of the atom.⁸⁰³ As [Paul Dirac](#) said in his 1933 Nobel Prize speech:

⁸⁰² Jonathan Katz, *The Biggest Bangs*, p. 46. Emphasis added.

⁸⁰³ Besides the ignoring of the First Law of Thermodynamics, a rather glaring anomaly in the “creation/annihilation” theory is that the resulting electron and positron both have

To get an interpretation of some modern experimental results one must suppose that particles can be created and annihilated. Thus if a particle is observed to come out from another particle, one can no longer be sure that the latter is composite. The former may have been created. The distinction between elementary particles and composite particles now becomes a matter of convenience. This reason alone is sufficient to compel one to give up the attractive philosophical idea that all matter is made up of one kind, or perhaps two kinds, of bricks.⁸⁰⁴

Actually, Dirac was being critical of the “creation” interpretation, but interpretations of this variety are still very popular today. Often, the more bizarre the theory, the better it sells to the media and the public at large. Various physicists have made a cottage industry out of such speculations. Stephen Hawking, for example, theorizes that in order to have higher than zero temperatures in black holes (a requirement to keep it stable), there must exist “virtual particles.” According to Hawking, these are particles that “pop in and out of the vacuum of space spontaneously.” Interestingly enough, Hawking holds that these “virtual particles” are mostly electron-positron pairs, and perhaps some proton-antiproton pairs. He writes:

Quantum mechanics implies that the whole of space is filled with pairs of “virtual” particles and antiparticles that are constantly materializing in pairs, separating, and then coming together again and annihilating each other. These particles are called virtual because, unlike “real” particles, they cannot be observed directly with a particle detector. Their indirect effects can nonetheless be measured, and their existence has been confirmed by a small shift (the “Lamb shift”) they produce in the spectrum of light from excited hydrogen atoms.⁸⁰⁵

He explains their origin in another paragraph:

When the universe was a single point, like the North Pole, it contained nothing. Yet there are now at least ten-to-the-eightieth particles in the part of the universe we can observe.

angular momentums equal to $\hbar/2$ ($\hbar = \text{Planck's constant}$). But this would necessarily mean that the electron or positron, respectively, would have 16 times (or 1,600%) more energy than the gamma photon that supposedly “created” it. Modern physics simply ignores the problem and refers to it as an “inherent property” of the process.

⁸⁰⁴ *World Treasury of Physics, Astronomy and Mathematics*, ed., T. Ferris, 1991, pp. 80-81.

⁸⁰⁵ *Black Holes and Baby Universes*, pp. 107-108.

Where did all these particles come from? The answer is that relativity and quantum mechanics allow matter to be created out of energy in the form of particle/antiparticle pairs. And where did the energy come from to create this matter? The answer is that it was borrowed from the gravitational energy of the universe.⁸⁰⁶

Again, the more logical and less mystifying interpretation is that the electron-positron pairs are not created through force but were already present, and the radiation of the “black hole” is enough to jar them loose (that is, if black holes actually exist). This solution, of course, would be the death knell for the Big Bang theory, as well as Relativity and Quantum Mechanics.

There is quite an intriguing story behind the “creation/annihilation” interpretation of Anderson’s positron discovery. As noted, physicist Paul Dirac had predicted the discovery of the positron in 1928. In fact, his famous equation predicted that the entire universe is made up of electron-positron pairs (we will call them electropons, henceforth).⁸⁰⁷ The most unique aspect of Dirac’s analysis was that his equation required two sets of electropon pairs, positive pairs and negative pairs.⁸⁰⁸ It was known as Dirac’s “sea.” For the Relativists who followed Einstein, Dirac’s model, although everyone knew it was very workable, merely raised the stakes in the ongoing “ether-war,” whose shots were first fired over forty years prior in the Michelson-Morley experiment (1887). In fact, in the same year that Dirac came out with his equation and through it predicted the positron’s existence, Michelson was doing his final interferometer experiment to detect the ether that Dayton Miller had found four years earlier. Dirac’s equation would be one more proof that Einstein incorrectly interpreted Michelson-Morley, the very experiment that hung Relativity in the balance.

This smell of ether was a stench in the nostrils of Relativists, but the budding science of Quantum Mechanics didn’t much like the odor either. [Werner Heisenberg](#) did everything but hire an assassin to foil Dirac’s work. He once referred to Dirac’s work as “learned trash which

⁸⁰⁶ *Black Holes and Baby Universes*, p. 97. In another place Hawking says that black holes “would be able to create electron-positron pairs and particles of zero mass” (*ibid.*, p. 109). We notice, however, that Hawking doesn’t tell us from where the gravitational energy originates if, according to the General Relativity theory he is employing, there was no matter to warp space-time.

⁸⁰⁷ Paul A. M. Dirac, *Proceedings of the Royal Society A*, 117, 610 (1928a); 118, 351 (1928b). P. A. M. Dirac, *Scientific American*, May 1963, p. 86. The equation took the form: $\sum_{\beta} [\sum_{\mu} (\gamma_{\mu})_{\alpha\beta} \theta/\theta x^{\mu} + mc/\hbar \theta_{\alpha\beta}] \psi_{\beta} = 0$.

⁸⁰⁸ This is because the energy-momentum-mass relation of $E^2 = c^2 p^2 + m^2 c^4$ requires both a positive and negative energy, such that $\pm E = (c^2 p^2 + m^2 c^4)^{1/2}$. Some hypothesize that the 2.7° Kelvin radiation is the interface between the negative and positive energy.

no one can take seriously.”⁸⁰⁹ Heisenberg got into the act because the stakes were raised high when Carl Anderson experimentally verified Dirac’s 1928 prediction of the positron just four years later (1932). Something had to be done, and done quickly, to destroy Dirac’s ether-based universe. For six years Heisenberg and his colleagues tried to find an error in Dirac’s equation, but to no avail. Finally, they decided to create their own fudge factor. Although Dirac’s equation required the negative energy electropon pairs to be raised to positive energy pairs, Heisenberg circumvented this process by claiming that the positive energy pairs were merely “created” and had no origin from negative energy. Similarly, as Dirac’s equation required the positive energy pairs to go back intermittently to the negative energy state, Heisenberg reinterpreted this to mean that the positive pairs were “annihilated.” If there was any inadvertent crossover between the negative and positive, Heisenberg’s quantum mechanics coined the words “vacuum fluctuation” or “Zero-Point fluctuation” to take care of that problem. Thus we have the dubious origin of the “creation/annihilation” interpretation of Carl Anderson’s 1932 experiment and a case in which the politics and intrigue of the science establishment is revealed.

The significance of the electropon phenomenon is noted in how it reflects on the essence of the Big Bang theory, and the inevitable problems it creates. The standard theory is told to the popular enthusiast in the science magazine, *Discover*:

Whenever a normal particle and an antiparticle meet, they annihilate each other, converting all their mass into energy in a pyrotechnic demonstration of Einstein’s famous law, $E = mc^2$. And therein lies the source of one of the greatest dilemmas of science. Physicists believe that by the time the universe was just 10^{-33} of a second old...the temperature had dropped from unimaginably hot to a mere 18 million billion billion degrees. That was cool enough for the first particles of mater and antimatter to condense from pure energy. But to balance the cosmic energy books – and to avoid violating the most fundamental laws of physics – matter and antimatter should have been created in exactly equal amounts. And then they should have promptly wiped each other out. Yet here we are. Somehow a bit of matter managed to survive.⁸¹⁰

The article proceeds to report that the scientists working on this problem have no clue how to solve it. One team of scientists, although

⁸⁰⁹ Werner Heisenberg, Letter to Wolfgang Pauli, February 8, 1934.

⁸¹⁰ Tim Folger, “Antimatter,” *Discover*, August 2004, p. 67-68. *Discover* notes that “Andrei Sakharov was the first to understand that the Big Bang actually created a crisis for physicists: How could they explain the absence of antimatter and the presence of matter in a cosmos where both should have almost instantaneously vanished?” (p. 69).

admitting that this theory is “extremely speculative” and has “no experimental evidence” to support it, proposes that the universe started with neutrinos that turned into electrons, positrons, protons and antiprotons, but finds that this solution “would have yielded more protons and antiprotons, leading to a fateful imbalance between matter and antimatter at the dawn of time,” to which his partner offers the consolation: “In the end there is irrefutable evidence that we are here.”⁸¹¹ Thank God for that.

Every time modern science tries to explain the present universe by relying on a process, the process fails to produce the universe they presently see. This is the perennial problem with the Big Bang theory: every twist and turn concocted to answer the anomalies it invariably confronts, invariably “violates the most fundamental laws of physics.” So either the new theories are wrong, or the “fundamental laws of physics” are wrong, or quite likely both are wrong. We can safely say, however, that when a theory is based on the idea that matter and energy are created out of thin air, then Middle Age alchemists and blood-letters never seem to be very far away. Not until men accept the fact that it was all brought into being simultaneously by an *ex nihilo* divine fiat, they will continue to go down the path of no return.

The Anderson discovery was also important for another reason. It revealed that space consists of very dense yet very stable electropon pairings, perhaps in some type of lattice or crystalline structure. Someone in the physics community should have surmised that light traveling through this dense medium would be directly affected. Physics had already been prompted to think in this vein with Einstein’s Nobel Prize-winning discovery in 1905 of the photoelectric effect (the process by which a photon of the right frequency releases an electron from metal), as well as [Arthur Compton’s](#) discovery in 1923 of the process by which a photon gives momentum to an electron, appropriately called the “Compton effect.” One might be led to think that, with the knowledge that light can be affected by, and produce, physical effects when it interacts with atomic particles, then observing consistent interferometer results of 4 km/sec over the course of more than 60 years (i.e., 1867-1932) should have suggested to them that light was being physically affected by some kind of substance in space. Unfortunately, as we all know too well, strong but unproven presuppositions (i.e., that the Earth was revolving around the sun at 30 km/sec) prohibited them from making that crucial link.

Another possible reason for modern science’s reluctance to accept that electropon pairs already exist and are not “created” is that it would force a wholly different explanation to such formulas as $E = mc^2$, explanations that are not dependent on Lorentz’s complex transformation equations or Einstein’s canons of tensor calculus. In other words, the alternative explanations would be physical, mechanical, and anti-

⁸¹¹ “Antimatter,” *Discover*, August 2004, p. 71.

Relativistic. That is, energy (E) is absorbed into open space resulting in the release of a mass of electrons and positrons (or various other possible particles), which can then be multiplied by the square of the speed of light to calculate the total amount of energy absorbed. In fact, accepting the electroton lattice model, one can arrive at $E = mc^2$ by a simple algebraic proportion.⁸¹²

That an electroton lattice may pervade all of open space and thus constitute the a salient part of the “ponderable” ether has been postulated for quite some time. Plasma physics, for example, has demonstrated that electroton pairs play an important role in almost every phenomenon in the cosmos, including stars, neutron-stars, pulsars, quasars and gamma-ray bursters.⁸¹³ Based on much physical evidence, several physicists have shown that an electroton lattice provides one of the most logical, lucid, and thoroughly physical explanations for nuclear and cosmological phenomena. Despite the unfortunate theoretical detour to which science drove itself after the 1887 Michelson-Morley experiment, there are a few modern scientists who haven’t succumbed to the *hocus pocus* of spatial warps, time dilations, and quantum uncertainties. All the mystery and confusion created by Relativity and Quantum Mechanics is suddenly evaporated once one understands the *physical* reasons (as opposed to the merely mathematical or theoretical) why things occur as they do.⁸¹⁴ For

⁸¹² If the product 300,000 km/sec is caused by the velocity (v) of the wave motion of the electroton lattice, then $v = (E/m)^{1/2}$ where m equals the mass of the electron or positron (9.1×10^{-31} kg), and E is the binding energy per particle (511,000 eV or 8.2×10^{-14} joules), the equation is: $v = (8.2 \times 10^{-14} \text{ joules} / 9.1 \times 10^{-31} \text{ kg})^{1/2} = (9 \times 10^{16} \text{ m}^2/\text{s}^2)^{1/2} = 3 \times 10^8 \text{ m/s} = 300,000 \text{ km/s} = c$, the accepted “speed” of light. Since $c = v$ in $v = (E/m)^{1/2}$, then $E = mc^2$. (See M. Simhony, *An Invitation to the Natural Physics of Matter, Space, Radiation*, Singapore, New Jersey: World Scientific, 1994, pp. 172-175.)

⁸¹³ *Electron-Positron Physics at the Z*, “Series in High Energy Physics, Cosmology and Gravitation,” M. G. Green, Royal Holloway and Bedford College, UK, January 1998. Plasma experimenters spend most of their time colliding electrons and positrons at just below luminal speeds producing an array of other strange particles. In fact, different particles are produced depending on how fast the electrons and positrons collide. Whether these are true particles or merely different bubble-chamber paths of the same particle remains on the debating table.

⁸¹⁴ Among the many contributors, Menahem Simhony has developed one of the most comprehensive explanations of matter, space, and energy. From the results of the 1932 discovery of the positron, Simhony’s model is based on the concept of an electron-positron cubical lattice comprising all of open space. Simhony holds that the density of the electron-positron pairs in space is $6 \times 10^{30} \text{ cm}^3$. This is precisely the same value found by another researcher in the field, Allen Rothwarf, although the two scientists worked independently (Allen Rothwarf, “Cosmological Implications of the Electron-Positron Ether,” *Physics Essays*, 11, 1998). John Kierein finds a similar density to the electron-positron model, and by it shows that redshift is due to the Compton effect (John Kierein, “Implications of the Compton Effect Interpretation of the Redshift,” *IEEE Trans. Plasma Science* 18, 61 (1990). Simhony asserts to have physical answers to gravity (p. 129), electromagnetism (p. 92), inertia (pp. 124, 212, 222), momentum (p. 162), the wave-particle duality (p. 163), the speed of light and superluminal speeds (p. 209), redshift (pp. 223, 249, 252), why atoms do not collapse (p. 193), evidence against

example, the origin of inertia could be simply explained, since around every micro and macro object there are billions of electropon pairs, which vibrate at a frequency proportional to the velocity of the object. If the object remains in uniform motion, so does the vibration energy of the electropon pairs. If there is any change in motion, the electropon pairs act accordingly, changing their frequency and energy. The energy required to change the values for the electropon pairs is equivalent to the inertial energy of the object. The same principle could hold for gravity. Any two bodies will disturb the equilibrium of the electropon pairs, and will do so based on their masses and the inverse square of the distance between them. Since the disturbance occurs between the bodies, the force will be felt there, and nowhere else.⁸¹⁵ In fact, because the electropons are in a lattice formation, they function very similar to crystalline structures. In light of this comparison, Robert Laughlin sheds some light as to how such crystalline structures transmit their energy:

The ability of electrons and holes to move ballistically through the lattice is not obvious at all....The resolution of this problem is that the entanglement is rendered irrelevant by emergence. It turns out to be exactly and universally the case that crystalline insulators have specific collective motions of isolated electrons that look and act as though they were motions of isolated electrons....The important thing is that the particle-like nature of the collective motion is exact and reliable.⁸¹⁶

As for magnetism, a free moving electron will simply attract the positron end of an electropon pair. Thus, as Maxwell wrote in 1873:

From the hypothesis that electric action is not a direct action between bodies at a distance, but is exerted by means of the medium between the bodies, we have deduced that this medium must be in a state of stress.⁸¹⁷

the Big Bang and expanding universe (pp. 241, 245-247, 254), black holes (p. 244), etc. Simhony, however, misinterprets the Michelson-Morley experiment, and therefore fails to equate the electron-positron pairs as a constituent part of the ether detected by the interferometer experiments (See M. Simhony, *An Invitation to the Natural Physics of Matter, Space, Radiation*, Singapore, New Jersey: World Scientific, 1994).

⁸¹⁵ According to Coulomb's law, the attractive force between the electron and positron is 42 orders (10^{42}) higher than the gravitational force, so these are very stable pairings.

⁸¹⁶ Robert B. Laughlin, *A Different Universe*, p. 66.

⁸¹⁷ James Clerk Maxwell, *A Treatise on Electricity and Magnetism*, Oxford University Press, London, 142, 670, 1873. Maxwell also said: "There can be no doubt that the interplanetary and interstellar spaces are not empty but are occupied by a material substance or body, which is certainly the largest, and probably the most uniform body of which we have any knowledge."

At the least, there are viable, physical, solutions at our disposal. Unfortunately, most physicists still think that the particles appearing in electroon collisions are created out of thin air, rather than being released from it, since opting for the latter would mean that space is substantive and that science has to go back to the drawing board.

In line with these insights is the discovery in 1911 by [Ernest Rutherford](#) when he bombarded very thin sheets of gold with alpha particles. He found that, even though alpha particles are 8,000 times larger than the electron, and the metal foil was 400-atoms-thick, nevertheless, most of the particles penetrated the foil with little problem. Only a few, perhaps 1 in 1,000, were scattered, some deflected 90 degrees, others 180 degrees. A viable interpretation of this phenomenon is that the alpha particles move through the atom as if it were almost completely empty. The few alpha particles that were deflected had done so because they hit the nucleus of the atom, which means that most of the mass and electric charge of the atom are concentrated at that central point. As it turns out, only a quadrillionth of the atom is occupied by mass. The rest is “empty space,” whatever one conceives that to be.

Naturally, Rutherford’s results bring up some intriguing questions that are not often given the proper spotlight. If only 0.000,000,000,01% of the typical atom is occupied by particles, what constitutes the other 99.999,999,999,9%? For lack of a better term, modern science calls it “empty space,” but what is empty space? We are back to our philosophical question introduced at the beginning of this chapter: Can “nothing” exist? It will do no good for the Relativist to appeal to General Relativity, for the fact remains that Rutherford’s alpha particles did not go through a time warp or a spatial curvature but through the “absolute” space between the nucleus and the swirling electrons of the atom.

Since the time of Rutherford, science has penetrated even farther into the atom. By the time we get down to quarks and leptons (the components of protons and neutrons), we are at dimensions of 10^{-18} centimeters in length, as opposed to 10^{-12} cm for the atom itself.⁸¹⁸ But we are still left with the “empty space” between the quark/leptons and the swirling electrons. Could this “empty space” be filled with particles even smaller than a length of 10^{-18} cm? Perhaps the electroon pairings constitute much of open space, but even then it looks like we need some help in packing the rest of the space with something even smaller.

⁸¹⁸ Some accelerators have produced evidence of “pentaquarks,” a collection of five different quarks, but the same evidence leads to the theory that there may be a dozen or more species of pentaquarks (J. R. Minkel, “The Power of Five,” *New Scientist*, July 3, 2004, p. 32).

The Ether of Quantum Mechanics

Ever since the dawn of quantum mechanics (a theory to which Einstein was bitterly opposed because any assignment of ponderable substance to space would explicitly contradict General Relativity), most of today's physical theorists hold that inner and outer space hold a dizzying array of particles and/or fields. Different names are given to these entities (e.g., gravitons, maximons, machions, etherons, axions, newtonites, neutrinos, higgsionos, fermions, bosons, zero-point energy field, material vacuum, cosmic false vacuum, *et cetera*). One popular physicist, [Brian Greene](#), admits that these entities are “modern echoes...of a space-filling ether.” He writes:

We then encounter subsequent discoveries that transformed the question once again by redefining the meaning of “empty,” envisioning that space is unavoidably suffused with what are called quantum fields and possibly a diffuse uniform energy called a cosmological constant – modern echoes of the old and discredited notion of a space-filling ether.⁸¹⁹

It has been known in modern science for quite some time that there exists a world permeating all of space that consists, perhaps, of the smallest functional dimensions known to man. As one author puts it:

Classically, a vacuum is simply the absence of matter. In quantum mechanics, however, the [Heisenberg] uncertainty principle leads us to view the vacuum as a very complex system. A particle-antiparticle pair can pop into existence in empty space, provided that the two annihilate each other in a time so short that the violation of energy conservation implicit in this process cannot be detected. The vacuum, then, is more like a pan of popcorn than a featureless, empty sea. Particle-antiparticle pairs pop into existence here and there, but disappear quickly.⁸²⁰

Nobel laureate Robert Laughlin shows us a little more of the history behind this discovery:

The existence and properties of antimatter are profoundly important clues to the nature of the universe....The simplest solution – and the one that turned out to be experimentally correct – was to describe space as a system of many particles similar to an ordinary rock. This is not a precisely correct statement, since Paul Dirac formulated the relativistic theory of

⁸¹⁹ Brian Greene, *The Fabric of the Cosmos*, New York, Alfred A Knopf, 2004, Preface, p. x. Brian Greene has also written the popular book, *The Elegant Universe*.

⁸²⁰ James Trefil, “The Accidental Universe,” *Science Digest*, June 1984, p. 100.

the electron...but in hindsight it is clear that they are exactly the same idea....This...has the fascinating implication that real light involves motion of something occupying the vacuum of space....The properties of empty space relevant to our lives show all the signs of being emergent phenomena characteristic of a phase of matter.⁸²¹

As we see, there is a whole other realm of particle-antiparticle pairs besides those of electroons. Quantum mechanics can only measure the effects of the particles. It does not know what the particles are, nor can it accurately predict what these particles will do in every case (as opposed to being able to predict what atoms will do). As noted above, quantum scientists refer to them as particles that “pop in and out of existence.”⁸²² The only thing they know for sure about them is that the First Law of Thermodynamics cannot be violated, and thus, in one zepto-second the particle is here, and in the next it must be gone, but to where no one knows.

Most of this strange, unseen world comes in what science knows as “Planck” dimensions, named after the physicist Max Planck due to his formulation of the quantum \hbar , the smallest unit of energy. It is in this world that lengths come as small as 10^{-33} cm; mass as ethereal as 10^{-5} grams; and time as short as 10^{-44} seconds. Comparing the Planck length to the size of an atom (10^{-13} cm) or an electron (10^{-20} cm), a Planck particle (which we call “plancktons,” henceforth) is 100,000,000,000,000,000,000 times smaller than the former and 1,000,000,000,000 times smaller than the latter. You can visualize its smallness by this analogy: if a drop of water were the size of Earth, an atom would be the size of a basketball, and a planckton would be about the size of the electrons in the basketball.⁸²³

How does modern science know plancktons exist? The logic of quantum physics leads them there. As Stephen Hawking puts it:

⁸²¹ Robert B. Laughlin, *A Different Universe*, pp. 103-105.

⁸²² As one popular magazine put it: “...according to quantum mechanics, empty space is not empty. Rather, the vacuum is filled with fields and particles that constantly pop in and out of existence. The problem is that when physicists estimate how much energy is contained within those fields and particles, they come up with a number...that is insanely large, 10^{120} times greater than what we observe” (*Discover*, October 2005, p. 56).

⁸²³ The Planck length is derived from the formula $\sqrt{(\hbar/c^3)}$, where G is the gravitational constant, \hbar is Planck’s constant of angular momentum, and c is the speed of light. This may be the fundamental length that would prohibit further division on an actual, not potential, basis. For further study, see V. L. Ginzburg, *Key Problems of Physics and Astronomy*, Moscow, Mir Publishers, 1976.

[T]he uncertainty principle means that even “empty” space is filled with pairs of virtual particles and antiparticles... (unlike real particles, they cannot be observed directly with a particle detector)... If it weren’t – if “empty” space were really completely empty – that would mean that all the fields, such as the gravitational and electromagnetic fields, would have to be exactly zero. However, the value of a field and its rate of change with time are like position and velocity of a particle: the uncertainty principle implies that the more accurately one knows one of these quantities, the less accurately one can know the other. So if a field in empty space were fixed at exactly zero, then it would have both a precise value (zero) and a precise rate of change (also zero), in violation of that principle. Thus there must be a certain minimum amount of uncertainty, or quantum fluctuations, in the value of the field.⁸²⁴

As we noted above, these particles are said to be continually “popping in and out” of space. In fact, as modern science interprets the appearance and disappearance of electron pairs to be an example of the creation and annihilation of matter, they make a similar interpretation in explaining why planktons appear and disappear in 10^{-44} seconds. To explain their appearance some physicists have gone to the extreme of saying that these particles come from other universes or dimensions, visiting us for very brief “Planck” periods.⁸²⁵ In that sense also they are understood as “virtual” particles, not real particles. In 1957, Princeton professor [John Wheeler](#) was the first to describe this phenomenon as “space-time foam” – a universe of virtual particles appearing and disappearing in Planck time through blackholes.⁸²⁶ Ironically, Wheeler was also quoted as saying that blackholes were “the greatest crisis ever faced by physics.”⁸²⁷ Stephen Hawking supports Wheeler’s theory, stating that, on extremely small scales in the Planck dimensions, space is alive with “turbid random activity and gargantuan masses,” while “wormholes” provide passage to other universes.⁸²⁸ Others, such as Ian Redmount and Wai-Mo Suen speak of “quantum space-time foam” or

⁸²⁴ Stephen Hawking, *A Briefer History of Time*, pp. 122-123.

⁸²⁵ MIT physicist, Alan Guth and Russian physicist Andrei Linde.

⁸²⁶ John A. Wheeler and C. M. Patton, “Is Physics Legislated by Cosmology?” *The Encyclopedia of Ignorance*, editors: Ronald Duncan and Miranda Weston-Smith, *Pocket Books*, 1978, pp. 19-35.

⁸²⁷ “Those Baffling Black Holes,” *Time*, Sept. 4, 1978.

⁸²⁸ *Black Holes and Baby Universes and Other Essays*, Bantam Books, 1994; *A Briefer History of Time*, pp. 104-123.

“Lorentzian space-time foam,”⁸²⁹ as does S. J. Prokhorovnik.⁸³⁰ F. Selleri understands the CMB as the fundamental reference frame, pointing out that any object that travels through it is affected by radiation pressure.⁸³¹ Jean-Pierre Vigièr refers to it as a “non-empty vacuum” and outlines the phenomenon of superluminal interactions in an “underlying deterministic substructure.”⁸³² Vigièr points to the experiments by Alain Aspect, which confirm the results.⁸³³ Robert Moon, professor emeritus in physics at University of Chicago, adds:

According to accepted theory, free space is a vacuum. If this is so, how can it exhibit impedance. But it does. The answer, of course, is that there is no such thing as a vacuum, and what we call free space has structure. The impedance equals 376+ ohms.⁸³⁴

Many theorists appeal to ultra small particles to explain the phenomenon of gravity, which has hitherto defied the efforts of modern science to uncover its physical mechanism. In trying to explain gravity as a process of interacting particles, the “empty space” of the cosmos is said to be filled with particles going by such names as “gravitons,” “machions,” “messenger particles,” or “force-carrier particles.” Included among these particles are electropon pairs, which are said to have a time-scale existence of 10^{-21} seconds. Another explanation, going by the name of String Theory, holds that, rather than space being filled with point particles, it consists of one-dimensional “strings” that are 10^{-33} cm in length. The particles we are detecting are merely oscillations of the strings. This theory requires the existence of 10 or more dimensions to

⁸²⁹ *Physical Review D*, 3rd series, vol. 47, No. 6, March 1993; I. Redmount and W.-M. Suen, “Is Quantum Spacetime Foam Unstable?” *Rapid Communication, Physical Review D*, 47, 2163 (1993); “De Broglie Waves on Dirac Ether,” *Lettere Al Nuovo Cimento*, vol. 29, No. 14, Dec. 1980; W.-M. Suen, “Minkowski Spacetime is Unstable in Semi-Classical Gravity,” *Physical Review Letters*, 62, 2217 (1989).

⁸³⁰ S. J. Prokhorovnik, “Light in Einstein’s Universe,” Dordrecht, Reidel, 1985; “A Cosmological Basis for Bell’s View on Quantum and Relativistic Physics,” in *Bell’s Theorem and the Foundation of Modern Physics*, eds., A. Van der Merwe, F. Selleri and G. Tarozzi, Singapore, New Jersey, World Scientific, 1990, pp. 508-514.

⁸³¹ F. Selleri, “Space-time Transformations in Ether Theories,” *Z. Naturforsch*, 46a, 1990, pp. 419-425.

⁸³² J. P. Vigièr, “Causal Superluminal Interpretation of the Einstein-Podolsky-Rosen Paradox,” and “New non-zero photon mass interpretation of Sagnac effect as direct experimental justification of the Langevin paradox,” *Physics Letters A*, 234, 1997, pp. 75-85; *Physics Letters A* 175, 1993, p. 269.

⁸³³ *Physical Review Letters*, vol. 49, No. 2, July 12, 1982.

⁸³⁴ “Space Must Be Quantized,” *21st Century*, May-June, 1988, p. 26ff.

make everything fit, which are given various exotic names such as “Calabi-Yau manifolds.”⁸³⁵

Other discoveries also added to the mystery. In 1948 Hendrik Casimir discovered that two mirrors facing each other in a perfect vacuum have a mysterious force acting upon them that draws them together, which is appropriately called “the Casimir effect.”⁸³⁶ This is a force that seems to appear out of nowhere, since in a vacuum there would be no obvious forces or material substances carrying them, yet a force it was. Current science tries to explain the appearance of this force as a “vacuum fluctuation” wherein the aforementioned “virtual particles” do their magic, but this is merely theoretical phraseology for something they really don’t understand. One interesting theory held by the editor of the *Astrophysical Journal*, Bernard Haisch, is that the Casimir effect shows the existence of a “zero-point field” and is the scientific fulfillment of the opening verses of Genesis 1:3, “Let there be light.”⁸³⁷

⁸³⁵ Brian Greene, *The Fabric of the Cosmos: Space, Time and the Texture of Reality*, New York: Alfred A. Knopf, 2004, p. 369.

⁸³⁶ Hendrik B. G. Casimir, Proc. Kon. Ned. Akad. Wetensch. B51, 793, 1948; S. Lamoreaux, *Physical Review Letters*, 78, 5, 1996; M. Bordag, U. Mohideen and V. M. Mostepanenko, “New developments in the Casimir effect,” *Phys. Rep.* 353 1, 2001; H. B. Chan, et al., “Nonlinear micromechanical Casimir oscillator,” *Physical Review Letters* 87, 211801, 2001; F. Chen and U. Mohideen, “Demonstration of the lateral Casimir force,” *Physical Review Letters* 88, 101801, 2002; C. Genet, A. Lambrecht and S. Reynaud, “Temperature dependence of the Casimir force between metallic mirrors,” *Physical Review A* 62 012110, 2000; K. Lamoreaux, “Demonstration of the Casimir force in the 0.6 to 6 micrometer range,” *Physical Review Letters* 78 5, 1997; K. A. Milton, *The Casimir Effect: Physical Manifestations of Zero-point Energy*, World Scientific, Singapore, 2001. The Casimir Effect also causes one to wonder whether the Gravitational constant G in Newton’s force equation [$F = Gm_1m_2/r^2$] is, indeed, caused by gravity or some other force, since its value was determined in 1798 based on the attraction of metallic spheres in close proximity to one another. Stephen Mooney holds that the Cavendish Torsion Balance measures electrostatic attraction, not gravitational attraction. He points out that when Cavendish conducted the test, he found perplexing the fact that the attraction between the two spheres increased when he heated the larger of the two. Mooney believes the reason is that Cavendish was measuring the radiation density at the Earth’s surface (which is not a constant value), not gravitational attraction (Stephen Mooney, “From the Cause of Gravity to the Revolution of Science,” *Apeiron*, vol. 6, no. 1-2, pp. 138-141, 1999). Science is not agreed on the value of G in any case. Most disagree on its value after only three decimal places, and some disagree even after one decimal.

⁸³⁷ Bernard Haisch, scientific editor of *The Astrophysical Journal* and editor-in-chief of the *Journal of Scientific Exploration*, has postulated that the Casimir Effect is due to the exclusion of the zero-point field from the gap between the plates, which was worthy enough to be published by *Physical Review*, (B. Haisch, A. Rueda, and H.E. Puthoff, *Physical Review A*, 49, 678, 1994. In an article in *Science and Spirit Magazine* titled “Brilliant Disguise: Light, Matter and the Zero-Point Field,” Haisch coincides his findings with Genesis 1:3’s “Let there be light.” Haisch holds that the zero-point energy field results when, due to the Heisenberg Uncertainty Principle which says that there will be continual random movement in electromagnetic waves, if all the energy in those random movements are added up, it will produce the “background sea of light whose

Although Haisch's exuberance may be somewhat misplaced, it is obvious that he knows *something* is there, and it is far smaller than the dimensions we see on the atomic level. Accordingly, other physicists recognize that it is high-time Einstein's theories about gravity be replaced.⁸³⁸ All these discoveries spell a certain doom for the theories of Einstein because, try as they may, no one has been able to bridge the huge gap between Relativity and the Quantum world in which these particles are created and catalogued. In fact, Roger Penrose, who has coined the word "twistors" as his particles of choice, has stated that the concept of "space-time" may be eliminated from the basis of physical theory altogether.⁸³⁹ Abhay Ashtekar holds that at the Planck scale the concept of space-time is replaced by a network of what he calls "loops and knots" of energy. This theory is being further developed by Carlo Rovelli and Lee Smolin.⁸⁴⁰

total energy is enormous: the zero-point field. The 'zero-point' refers to the fact that even though this energy is huge, it is the lowest possible energy state." Other articles include: "BEYOND $E=mc^2$: A First Glimpse of a Post-modern Physics in Which Mass, Inertia and Gravity Arise from Underlying Electromagnetic Processes," B. Haisch, A. Rueda and H.E. Puthoff, *The Sciences*, November/December, Vol. 34, No. 6, pp. 26-31, 1994; B. Haisch, A. Rueda and H. E. Puthoff, "Inertia as a Zero Point Field Lorentz Force," *Physical Review A*, Vol. 49, No. 2, 1994; B Haisch and A. Rueda, "Electromagnetic Zero-Point Field as Active Energy Source in the Intergalactic Medium," presented at 35th Jet Propulsion Conference, June 1999. "Vacuum Zero-Point Field Pressure Instability in Astrophysical Plasmas and the Formation of Cosmic Voids," A. Rueda, B. Haisch and D. C. Cole, *Astrophysical Journal*, 445, 7, 1995; Puthoff, H.E., "Gravity as a Zero Point Fluctuation Force", *Physical Review A*, Vol. 39, No. 5, 1989; R. Matthews, "Inertia: Does Empty Space Put Up the Resistance?" *Science*, Vol. 263, 1994.

⁸³⁸ H. Yilmaz, "Towards a Field Theory of Gravitation," *Il Nuovo Cimento*, Vol. 107B, no. 8, 1991; I. Peterson, "A New Gravity? Challenging Einstein's General Theory of Relativity," *Science News*, Vol. 146, 1994; J. P. Siepmann, "The Laws of Space and Observation," *Journal of Theoretics*, Vol. 1, No. 1, 1999.

⁸³⁹ Roger Penrose, *The Road to Reality: A Complete Guide to the Laws of the Universe*, New York, Alfred Knopf, 2005, pp. 968-1002.

⁸⁴⁰ Lee Smolin, "Atoms of Space and Time," *Scientific American*, Sept. 2004; A. Ashtekar, V. Husain, J. Samuel, C. Rovelli, L. Smolin: "2+1 quantum gravity as a toy model for the 3+1 theory," *Classical and Quantum Gravity* 6, L185, 1989; C. Rovelli: "Loop space representation In: New perspectives in canonical gravity," A. Ashtekar Bibliopolis, Naples 1988; C. Rovelli and L. Smolin: "Knot theory and quantum gravity," *Physical Review Letters* 61, 1155, 1988; C. Rovelli, L. Smolin: "Loop space representation for quantum general relativity," *Nuclear Physics* B331, 80, 1990; A. Ashtekar, C. Rovelli, L. Smolin: "Gravitons and loops," *Physical Review* D44, 1740, 1991; A. Ashtekar, C. Rovelli: "Connections, loops and quantum general relativity," *Classical and Quantum Gravity* 9, 3, 1992; J. Iwasaki, C. Rovelli: "Gravitons from loops: non-perturbative loop-space quantum gravity contains the graviton-physics approximation," *Classical and Quantum Gravity* 11, 1653, 1994; H. Morales-Tecotl and C. Rovelli: "Loop space representation of quantum fermions and gravity," *Nuclear Physics* B 451, 325, 1995; C. Rovelli and L. Smolin: "Spin Networks and Quantum Gravity," *Physical Review* D 53, 5743, 1995; gr-qc/9505006. Lee Smolin argues that

The seeming inevitable position to which science is being led is that there is a world of activity occurring at Planck dimensions that underlies everything that happens in the universe. Obtaining the right understanding of this Planck universe will ultimately set aside both Relativity and Quantum Mechanics. Even staunch Relativists admit this eventuality. As Alan Kostelecký writes in *Scientific American*: “The observable effects of Planck-scale Relativity violations are likely to lie in the range of 10^{-34} to 10^{-17} .”⁸⁴¹ Kostelecký more or less admits that, even though the ultimate theory of nature lies in these tiny dimensions, current science is at a loss to investigate them:

Whatever the eventual form of the ultimate theory, quantum physics and gravity are expected to become inextricably intertwined at a fundamental length scale of about 10^{-35} meters, which is called the Planck length, after the 19th century German physicist Max Planck. The Planck length is far too small to be within the direct reach of either conventional microscopes or less conventional ones such as high-energy particle colliders (which probe “merely” down to about 10^{-19} meter).⁸⁴²

The magazine itself adds:

In quantum physics, short distance and short times correspond to high momenta and high energies. Thus, at sufficiently high energy – the so-called Planck energy – a particle should “see” the graininess of spacetime. That violates relativity, which depends on spacetime being smooth down to the tiniest size scales.⁸⁴³

It predicts the same doom, however, for Quantum Mechanics itself:

space is proportional to the area of its boundary in Planck units establishes a fundamental limitation on the nature of physical systems, called the “Bekenstein” bound. The power of this principle lies in its universality—any viable theory of quantum gravity must explain why it holds (“Three Roads to Quantum Gravity,” Basic Books, 2001).

⁸⁴¹ Alan Kostelecký, “The Search for Relativity Violations,” *Scientific American*, September 2004, p. 96.

⁸⁴² Alan Kostelecký, “The Search for Relativity Violations,” *Scientific American*, September 2004, p. 96.

⁸⁴³ Graham P. Collins, staff writer, *Scientific American*, Sept. 2004, p. 99. NB: We are not here supporting the concept of “space-time,” but merely using the same terminology of modern science as they discover the contradictions and anomalies in their own theories.

Still, something is rotten in the state of quantumland, too. As Einstein was among the first to realize, quantum mechanics, too, is incomplete. It offers no reason for why individual physical events happen, provides no way to get at objects' intrinsic properties and has no compelling conceptual foundations.⁸⁴⁴

In Quantum Land, virtual particles can do just about anything the theorist desires they do, including traveling faster than the speed of light or escaping from a black hole. There is one catch, though. The math of Quantum Mechanics maintains that, if they travel faster than the speed of light, they better “pop out of existence” prior to any violation of the Heisenberg Uncertainty Principle, otherwise, they cannot exist.

In the end, those who depend on “virtual” particles with word pictures such as “space-time foam” or “non-empty vacuum” have admitted, however, that the whole system of “virtual” particles is doomed from the start. Redmount and Suen have shown that if plancktons are left in the “pop in and pop out” category it creates numerous anomalies in the structure of the quantum field, including but not limited to “wormholes” on an intolerable scale.⁸⁴⁵ This leads one to posit that the plancktons should be understood as real particles, the underlying substance of the Genesis firmament itself. We will cover this possibility momentarily.

⁸⁴⁴ George Musser, “Was Einstein Right,” *Scientific American*, September 2004, p. 89.

⁸⁴⁵ I. Redmount and W.-M. Suen, “Is Quantum Spacetime Foam Unstable?” *Rapid Communication, Physical Review D*, 47, 2163, 1993.

String Theory Seeking to Bridge Einstein and Quantum Mechanics

As we noted, some have even entertained the idea that other universes exist in different dimensions, universes that sometimes interact with our universe by sharing virtual particles with us. In a rather amusing assessment of current theories, *Popular Science* editor Michael Moyer describes his trip through the maze of quantum mechanics:

Things happen in more than three dimensions of space; to see them in only three is to succumb to a trick that the universe is constantly playing on us....Type of possible space #1: A 10-dimensional universe made up of the normal three dimensions of space, plus one of time, plus six-dimensional Calabi-Yau manifolds...I'm not making this up. I am only attempting to report to you, dear reader, what I have heard smart people say....When scientists talk about extra dimensions, they actively avoid the use of English....So they use the language of math, whose concepts and terms are easily generalized into any number of dimensions or spaces or inconceivable, unphysical situations... string theory carries with it great hope for both particle physics...and cosmology. Both are beset with problems, "problems" here meaning deep chasms of ignorance in our understanding of the physical world...

Type of possible space #2: The universe as we know it is merely a three-dimensional brane suspended in a four-dimensional bulk. What the %\$#& is a brane?...You live on a brane. A brane is like a membrane. Imagine the skin that forms on your soup when it gets cold. A brane is like that....Like so much congealed fat, we are prevented from escaping the brane and going into the higher dimensional soup. Only gravity is allowed to do that. The problem that had been confounding all of these smart people for so long (and continues to confound them; did I mention that none of what I'm describing has yet been supported by a shred of experimental evidence?) was this: Gravity is weak....Everything else works fine; gravity is the oddball of the particle family....OK, so where does gravity fit into all this? Just treat it like any other force – gravity is caused by massive particles throwing "gravitons," attractive particles, at each other....You may have caught wind of another theory of gravity called general relativity. A fellow named Einstein came up with it almost 100 years ago. Conceptually, it could not be any more different from the standard model. General relativity explains gravity by invoking the warping of space-time; the standard model explains it and everything else by invoking the exchange of subatomic particles. Problems happen when we try to put the two theories together....Problems like mathematical inconsistencies, zeroes in denominators, nonsensical results....Yet, as we have seen,

gravity is much weaker than every other force....According to brane theory, we lose gravitons out into the fourth dimension. The result: Gravity is weak....Gravitons, like photons, do not possess the property known as mass. They weigh nothing...there is another, mirror brane located as little as a millimeter or so away from us at all times, but which we can never reach, because we are not gravitons...⁸⁴⁶

Gravity has been the fly in the ointment of every theory concocted by modern science. A theory may be able to explain (at least within its own framework) about 75% of nature, but if it fails to explain the 25% due to gravity, then the whole theory is brought to naught. String theory is the invention of a handful of scientists seeking for some solution to the intractable problem created when one attempts to combine General Relativity's explanation of gravity with Quantum Mechanics' explanation of the nuclear forces holding the atom together. General Relativity could explain things (at least mathematically) on the macroscale (e.g., planets, stars), and Quantum Mechanics could do the same on the microscale (e.g., atoms, quarks), but in instances when the macro met the micro, as is the case, for example, when a star of great mass is said to collapse into an infinitesimal point particle (e.g., a "blackhole"), then both theories break down, producing nonsense, both physically and mathematically.

The refusal of Relativity to marry Quantum Mechanics also means that no children will be produced from that non-union. Science is stymied, and they will continue to be stymied. Not willing to admit that their mathematical inventions of General Relativity and Quantum Mechanics do not represent physical reality, and desperately seeking a solution other than constituting the universe with 95% make-believe matter (i.e., Dark Matter), a group of these puzzled scientists invented another mathematical model hoping to combine the two disciplines into one unified formula, or what was dubbed as a "theory of everything."⁸⁴⁷

Three of the pioneers in this search were [Leonard Susskind](#), Michael Green and John Schwarz. To get the ball rolling, Susskind borrowed a formula from mathematician [Leonhard Euler](#) (d. 1783) and applied it to the strong force between atoms. Then Green and Schwarz were successful in 1984 in working out a mathematical formula that at least balanced both sides of the equal sign. Their formula translated into a model of one-dimensional vibrating strings of energy that were said to compose the quarks and leptons of atoms. These vibrating strings were

⁸⁴⁶ Michael Moyer, "Journey to the 10th Dimension," *Popular Science*, March 2004.

⁸⁴⁷ See Brian Greene, *The Elegant Universe: Superstrings, Hidden Dimensions, and the Quest for the Ultimate Theory*, New York, W. W. Norton & Company, 1999; Brian Greene, *The Fabric of the Cosmos: Space, Time and the Texture of Reality*, New York: Alfred A. Knopf, 2004.

said to be moveable and pliable, as opposed to the rigidity of point particles. They also came in many sizes and shapes, which were defined by the amount of vibration each string possessed, which in turn determined their function.

It was discovered in the late 1980s, however, that the mathematics of String Theory produced five different yet five valid theories. Some theories were radically different from the others. Some had closed strings, others had open strings, and some even required at least 26 dimensions in order to function. The acknowledged “Einstein” of Quantum Mechanics, Edward Witten, supposedly found a solution, proposing that each was simply a different way of looking at the results. The new perspective was called “M-theory” (for reasons no one is quite sure). Still, the bad news was that these strings needed six extra dimensions (other than the three we have already) in order to do their specific jobs. In brief, the extra dimensions were the means to overcome the barriers of Relativity theory that limits anything from traveling faster than the speed of light. The multiple dimensions of String Theory allowed matter to take a “short cut,” as it were, through dimensions that Relativity did not possess. To help justify the six dimensions, String advocates borrowed from the theory of Theodore Kaluza and Oskar Klein who had proposed in the early 1920s that a fifth dimension existed that carried electromagnetic waves. Hermann Minkowski had already added time as a fourth dimension in order to make the mysterious entity “space-time.”⁸⁴⁸ String theorists reasoned that if there can be four or five dimensions, why not ten or eleven? As we noted above, “branes” or membranes were invented to help solve this problem.

Still, the mathematics of String Theory eventually led the extra dimensions to the same absurd infinities that hampered General Relativity, yet, for reasons that String theorists can only rationalize by appealing to the “anthropic principle” (i.e., things are the way they are because we wouldn’t be here if they were any other way), somehow we are magically left with only three spatial dimensions (length, height and width) that aren’t absorbed into infinity. Alas, String Theory doesn’t really explain anything. It is merely a mathematical model, and a desperate one at that, with no physical proof, and none in sight. It reaches a virtual dead end, and science is left without a solution to the

⁸⁴⁸ Charles Lane Poor divests Minkowski’s “fourth dimension” of its mystique quite easily. He writes: “To most people, the very words, four dimensions, are enough; everything at once becomes incomprehensible and absurd. Yet there is no reason for this too prevalent idea: in the broad sense of the words, there is nothing new or startling in the four dimensional idea. It is a matter of common, every-day knowledge that, in order to describe fully an event, we must tell not only where the event took place, but when” (*Gravitation versus Relativity*, p. 37).

blem of how to combine General Relativity with Quantum Mechanics.⁸⁴⁹

The real solution, of course, is that both Relativity and Quantum Mechanics are failed theories of reality in themselves, and this inadequacy shows up very clearly when schemes to combine the theories must be aborted. But since modern science has wedded itself to the Big Bang process, it will be forever trapped in theories that simply don't work. The only possible explanation is that the universe was created by divine fiat, *ex nihilo*, but it is that precise solution that modern man is unwilling to accept. It is not "branes" that collide to make universes, it is God who creates, and the first thing with which He started was Earth, in the center of it all, as Genesis 1:2 clearly states. Until science realizes this simple fact, it will be dreaming up theories that produce dead ends. As physicist Michael Duff was wise enough to admit:

Well, the question we often ask ourselves as we work through our equations is: 'Is this just fancy mathematics, or is it describing the real world?'...Oh yes, it's certainly a logical possibility that we've all been wasting our time for the last twenty years and that the theory is completely wrong.⁸⁵⁰

⁸⁴⁹ Imaginations certainly run wild in the "objective" world of modern science. Leonard Susskind has recently advocated that String Theory predicts as many as 10^{500} different universes, each with its own set of physical properties. Out of the 10^{500} possible universes, Susskind admits he has no reason why our single universe, with its unique biological life, came into existence, but he insists, nevertheless, "that it cannot be due to Intelligent Design" (Leonard Susskind, *The Cosmic Landscape: String Theory and the Illusion of Intelligent Design*, Little, Brown and Co., 2005).

⁸⁵⁰ "A Conversation with Brian Greene," Nova television series, Public Broadcasting Service, October 2004.

Can Modern Man Live in the Universe He has Fashioned?

As we often discover among famous scientists and philosophers who develop their unique theories, although their thoughts are logical according to their own premises, those same ruminations will not allow the inventor to live in the system he has created. The existentialist says everything is absurd, but he can't live in an absurd world. The nihilist says everything leads to anarchy, but he can't live in a world of anarchy. The atheist denies the existence of God, but foxholes have a way of persuading him otherwise. The evolutionist says everything is by chance, but he is very careful to avoid walking in front of moving traffic and choosing food that is non-poisonous.

[John Cage](#), the famous composer of the mid-twentieth century, is a perfect example of the dichotomy in which modern man finds himself. Cage made a name for himself by performing concerts based on *musique concrète*. To impress upon his audience that we lived in a universe of chance where all is relative, Cage used mechanical musical conductors that operated by random action, leading the orchestra members to play their instruments haphazardly. The “music,” of course, became a mere collection of noises with no meter or melody. At the end of the concert the orchestra would often hiss at Cage while he took his bow to the audience in order to register its discontent. Yet there was an obvious contradiction between Cage's philosophy and his practical life. In addition to being a famous conductor, John Cage was also a world famous mycologist (one who specializes in the study of mushrooms). He had one of the most extensive private libraries ever compiled on the subject. Since some mushrooms are poisonous, Cage had to be very careful which ones he consumed. As he said himself: “I became aware that if I approached mushrooms in the spirit of my chance operations, I would die shortly....So I decided that I would not approach them in this way!”⁸⁵¹ Obviously, he could not live in the “chance” world he created for himself.

Austrian physicist [Erwin Schrödinger](#) (d. 1961) one of the world's premier scientists and the inventor of Quantum Mechanics, found himself in the same dilemma. At one point he stated: “I do not like it [quantum mechanics], and I am sorry I ever had anything to do with it.” In his 1945 book *What is Life* he admitted that discovering the true laws of nature may be beyond human understanding. Since physics had not, and to this day has still not, settled on whether the electron is a particle, a wave or some combination of the two; or how the electron can seem to be in two places at the same time (otherwise known as “superposition of states” or “entanglement”), Schrödinger wanted to demonstrate the unlivable absurdities to which his theories often led. He

⁸⁵¹ Calvin Thomas in *The New Yorker*, November 28, 1964, as cited in Francis Schaeffer's *The God Who is There* (Crossway Books, 1990), p. 79.

thus introduced the world to his famous feline, otherwise known as “Schrödinger’s Cat.” As one author puts it:

A cat is in a box with a lid that is shut. Within the box is a radioactive atom that has a 50-50 chance of decaying in an hour. If the atom decays this triggers a mechanism that breaks a vial of poison gas which kills the cat. The cat has two states: alive or dead. Schrödinger argued that if we take seriously the idea of the superposition of states [of atomic particles] then we must write, for the cat’s state: $\text{cat} > = a/\text{alive} > + b/\text{dead} >$, that is, the cat apparently is in a superposed state of life and death! Then we open the box. According to the measurement hypothesis (discussed next) when we open the box, we are performing a measurement of the cat’s state; this is said to cause the cat’s superposed state to collapse into one base state or the other. The cat is found either pushing up the daisies, or purring for its milk. Schrödinger found this so totally absurd that (like Einstein) he could not bring himself to embrace fully the new mechanics he helped create.⁸⁵²

As noted, the same kinds of dichotomies began to penetrate the soul of Albert Einstein. Here is how his biographer describes the series of events:

They had solved individual problems, but they had done nothing to replace the all-embracing pattern of classical physics which they had first questioned, then shattered. Planck’s quantum theory, Einstein’s photons, Rutherford’s first ground plan of the nuclear atom and Bohr’s disturbing explanation of it – had each provided isolated answers to isolated problems. Yet in the process they seemed to have produced more riddles than they had solved. ‘By the spring of 1925,’ writes Martin Klein, ‘the theoretical picture had been elaborated by the work of many physicists into a tantalizingly incomplete and confused tangle of successes and failures, so that Wolfgang Pauli, one of the most acute, and most outspoken, of the young theorists could write to a friend: ‘Physics is very muddled again at the moment; it is much too hard for me anyway, and I wish I were

⁸⁵² Physics.fsu.edu. In 1957, Princeton University scientist, Hugh Everett, explained the “superposition of states” as evidence of a parallel universe, claiming that the cat is both dead and alive, that is, dead in one universe and alive in another. Before Schrödinger’s box is opened, the parallel universes exist simultaneously, but when the box is opened this causes the universes to separate and the superposition is terminated. Still, one cannot predict whether he will find a dead cat or a living car before the box is opened. Two opposing philosophical/scientific interpretations flow from this unpredictability: (a) the Copenhagen interpretation led by Niels Bohr, which states that subatomic particles, by nature, *do not have* defined properties; and (b) Einstein’s theory that subatomic particles, by nature, *do have* defined properties, but our instruments our woefully inadequate to determine them with any accuracy.

a movie comedian or something like that and had never heard anything about physics.⁸⁵³

⁸⁵³ *Einstein: The Life and Times*, pp. 405-406. His teacher once told Max Planck: “Physics is finished, young man. It’s a dead-end street,” then advised Planck to become a concert pianist instead (Nick Herbert *Quantum Reality*, p. 31).

The Copenhagen Perspective

Clark then traces the steps that led to the absurd conclusions of quantum mechanics, especially those of the Copenhagen variety.

A fundamental premise of classical physics was that events followed each other in succession on a basis which could be predicted if only one understood the laws of nature and had sufficient facts....Certain factors in the quantum theory had first cast a ray of doubt upon this comfortable assumption: the electron in the Bohr atom, jumping from one orbit to another without obvious cause, tended to increase this doubt. Was there, perhaps, no real 'cause' for such movements?...Might not the whole conception of causality in the universe be merely an illusion? This possibility had already gravely disturbed Einstein...and as early as January, 1920, he had voiced his doubts to Max Born. 'The question of causality worries me also a lot.'⁸⁵⁴

After the contributions of Louis de Broglie and Erwin Schrödinger, things began to move rapidly:

What had thus occurred within a very few years was a steady merging of the particle and wave concept. The electron...appeared that it was both at the same time. Here it seemed that science had run up not only against 'common sense,' which was already suspect when it began to deal with events in the subatomic world, but against rational logic. For could anything really be one thing and its opposite at one and the same time?⁸⁵⁵

Which then led to the inevitable climax:

Schrödinger's wave mechanics...was thus credible on the grounds that reality is what you make it. This was disturbing enough to those who believed that all ignorance in science could be removed by an addition of knowledge. But more was to follow...a totally different approach was being made by Werner Heisenberg....Thus by 1927 the de Broglie-Schrödinger picture of the electron was being matched by a purely mathematical explanation of the atom....The suggestion that a satisfactory picture of the physical world could consist not of a description of events but of their probabilities had

⁸⁵⁴ *Einstein: The Life and Times*, pp. 406-407.

⁸⁵⁵ *Einstein: The Life and Times*, p. 410.

already been made in Heisenberg's famous 'uncertainty principle.'⁸⁵⁶

The significant outcome of these events was, as de Broglie put it many years later, quantum physics now appeared to be "...governed by statistical laws and not by any casual mechanisms, hidden or otherwise. The 'wave' of wave mechanics ceased to be a physical reality...The corpuscle, too, was turned into a mere phantom..."⁸⁵⁷ The Copenhagen interpretation of Quantum Mechanics, and virtually all of modern physics today, holds that matter does not exist until an observer looks at it, or that matter does not exist independently of the observer. It is the observer's previous knowledge of the matter that creates its physical reality. More technically, all of matter is understood as a "wave function," a surreal explanation of the universe that expresses itself only in mathematical equations. When the observer looks in any direction, his mere glance is said to "collapse the wave function," and thus he sees the material object before him. This "collapse" is the main reason that science can think of light both as a particle and a wave, simultaneously. In effect, the "wave" of light "collapses" when one observes it and thus one can then "see" the particle.

If one tends to think these ideas are absurd, one is in good company. [Richard Feynman](#), one of the premier physicists in the world during his day, admits: "The theory of quantum electrodynamics describes Nature as absurd from the point of view of common sense. And it agrees fully with experiments. So I hope you can accept Nature as she is – absurd."⁸⁵⁸ Or as Werner Heisenberg puts it: "The law of causality is no longer applied in quantum mechanics."⁸⁵⁹

⁸⁵⁶ *Einstein: The Life and Times*, pp. 410-411. Schrödinger further complicated the picture since his energy-momentum relationship ($E = p^2/2m$) was thoroughly anti-Relativistic. Paul Dirac tried to bridge this gap with his alternative to $E = mc^2$, namely, $E^2 = m^2c^4$. Schrödinger writes: "Surely you realize the whole idea of quantum jumps is bound to end in nonsense...if the jump is sudden, Einstein's idea of light quanta will admittedly lead us to the right wave number, but then we must ask ourselves how precisely the electron behaves during the jump. Why does it not emit a continuous spectrum, as electromagnetic theory demands? And what law governs its motion during the jump? In other words, the whole idea of quantum jumps is sheer fantasy." Niels Bohr retorts: "What you say is absolutely correct. But it does not prove that there are no quantum jumps. It only proves that we cannot describe them, that the representational concepts with which we describe events in daily life and experiments in classical physics are inadequate when it comes to describing quantum jumps" (as recorded by Werner Heisenberg in *Physics and Beyond*, 1971, pp. 73-74).

⁸⁵⁷ *Einstein: The Life and Times*, p. 412.

⁸⁵⁸ Richard P. Feynman, *The Strange Theory of Light and Matter*, Princeton University Press, 1988, p. 10.

⁸⁵⁹ Werner Heisenberg, *Physics and Philosophy: The Revolution in Modern Science*, New York, Harper and Row, 1966, p. 88.

Rather than question whether their own theories about Nature are absurd (which implies that they know very little about Nature), proud scientists like Feynman and Heisenberg would rather put the blame on Nature. Within this quagmire, men of Feynman's generation will never be able to come to the truth. They will only disguise their ignorance in mathematical equations. As Heisenberg himself admitted: "The paradoxes of the dualism between wave picture and particle picture were not solved; they were hidden somehow in the mathematical scheme."⁸⁶⁰ In essence, the only difference between medieval superstition and modern physics is that the latter has the privilege of hiding its superstitions in complex equations that no one understands.

At this point Einstein had much trouble living in the universe that his Relativity theory helped create:

While Born, Heisenberg, and Bohr accepted it without qualification, Einstein and Planck accepted it only with the strongest qualifications. Yet these two were the very men who a quarter of a century earlier had pulled into physics the very ideas which they now thought of as its Trojan horse.

The break with the old world which this new concept epitomizes can be illustrated by two statements. One is by Sir Basil Schonland, who describes the new world in *The Atomist*. 'It appeared experimentally proven,' he says, 'that at the bottom of all phenomena there were to be discerned laws of chance which made it impossible to think of an ordered deterministic world; the basic laws of nature appeared to be fundamentally statistical and indeterminate, governed by the purest chance.'⁸⁶¹

Werner Heisenberg received fame in the physics world for what has become known as the *Uncertainty Principle* – a further blow to the pride of science. As noted earlier, this is a principle, accepted reluctantly by the entire scientific world (because they have no other choice), which states that there is no accurate way to measure size, distance and location in the sub-atomic world. As science had long been debating whether light and matter were made up of particles or waves,⁸⁶² Heisenberg

⁸⁶⁰ Werner Heisenberg, *Physics and Philosophy: The Revolution in Modern Science*, New York, Harper and Row, 1966, p. 40.

⁸⁶¹ *Einstein: The Life and Times*, pp. 412-413.

⁸⁶² The perplexity of the issue was brought out no better than the summation voiced in 1927 by Sir William Bragg, director of the Royal Institution: "On Mondays, Wednesdays, and Fridays we teach the wave theory and on Tuesdays, Thursdays, and Saturdays the corpuscular theory" (*Einstein: The Life and Times*, p. 420). Forty years later, when one would assume that science had a better grasp on the quantum world, Richard Feynman, one of its more prominent spokesmen, wrote: "I think I can safely

about anything anymore, big or small. We might say that there was both an Atomic Uncertainty Principle as well as a Cosmological Uncertainty Principle hampering the advancement of science.

The Demise of Relativity Theory

Einstein publicly criticized Heisenberg's *Uncertainty Principle* and Quantum Mechanics. But Quantum Mechanics, by depending on nothing more than statistical analysis, was having reasonable success in analyzing and predicting the effects of the subatomic world, and thus Einstein's opposition was more or less a losing battle. Einstein spent the rest of his career trying to meld General Relativity and Quantum Mechanics, without any success (and no success has come to anyone else). In fact, his post-Relativity career was virtually fruitless. This failure suggests (and Einstein was quite cognizant of it) that one or both of the theories are wrong. Hence, we can understand why he worked so feverishly to unify the two theories since, if he could show that the two worked together, he would save his own theory from being obliterated.

One example of such motivation appears to be that Quantum Mechanics would eventually lead to nullifying Einstein's most famous conception – “space-time” – and thus completely overthrow Relativity. As *Scientific American* describes it:

After all, relativity is riddled with holes – black holes. It predicts that stars can collapse to infinitesimal points but fails to explain what happens then. Clearly the theory is incomplete.... Moreover, quantum theory turns the clock back to a pre-Einsteinian conception of space and time. It says, for example, that an eight-liter bucket can hold eight times as much as a one-liter bucket. That is true in everyday life, but relativity cautions that the eight-liter bucket can ultimately hold only four times as much – that is, the true capacity of buckets goes up in proportion to their surface area rather than their volume. This restriction is known as the holographic limit. When the contents of the buckets are dense enough, exceeding the limit triggers a collapse to a black hole. Black holes may thus signal the breakdown not only of relativity but also of quantum theory (not to mention buckets).⁸⁶⁴

With revelations like the above, most physicists are quietly burying Einstein's theories in private ceremonies, but the public is not yet invited since it would burst – just a little too soon – the 100-year-old aura the scientific community created around him. Even his admirers are quite candid about the demise of Einstein's theories. Brian Greene writes:

Bell's reasoning and Aspect's experiments show that the kind of universe Einstein envisioned may exist in the mind, but not in reality. Einstein's was a universe in which what you do right here has immediate relevance only for things that are also right

⁸⁶⁴ George Musser, “Was Einstein Right,” *Scientific American*, Sept. 2004, p. 89.

here. Physics, in his view, was purely local. But we now see that the data rule out this kind of thinking; the data rule out this kind of universe.⁸⁶⁵

What the public knows of Einstein's inner turmoil, however, is merely his famous quote: "God does not play dice with the world," heard in every quarter of the civilized world. As Clark writes:

His feelings went deep, and were epitomized in the famous phrase...which he used in a letter to Max Born on December 12, 1926. 'Quantum mechanics is certainly imposing. But an inner voice tells me that it is not yet the real thing. The theory says a lot, but does not really bring us any closer to the secret of the Old One. I, at any rate, am convinced that He does not throw dice....As Einstein put it years later to James Franck: "I can, if the worst comes to the worst, still realize that the Good Lord may have created a world in which there are no natural laws. In short a chaos. But that there should be statistical laws with definite solutions, i.e., laws which compel the Good Lord to throw dice in each individual case, I find highly disagreeable."⁸⁶⁶

Here again we see that Einstein cannot live in the world to which his theories inevitably led. He now appeals to "the Old One," and more specifically "the Good Lord," as the preferred reference frame, as it were, for his critique of modern physics. Something deep inside forced him to become quasi-religious as the world he helped create got a little too crazy for even his sensibilities. In any case, Heisenberg, for one, was not moved by Einstein's appeals to "the Good Lord." He knew that Einstein was the very one who had opened Pandora's box. In one particular conversation, Heisenberg let him know just how hypocritical Einstein's position was:

⁸⁶⁵ Brian Greene, *The Fabric of the Cosmos: Space, Time and the Texture of Reality*, New York: Alfred A. Knopf, 2004, pp. 120-121.

⁸⁶⁶ *Einstein: The Life and Times*, p. 414. At the Fifth Solvay Congress in 1927, Neils Bohr further comments: "On his side, Einstein mockingly asked us whether we could really believe that the providential authorities took recourse to dice playing [...ob der liebe Gott würfelt]...I remember, also, how at the peak of the discussion Ehrenfest, in his affectionate manner of teasing his friends, jokingly hinted at the apparent similarity between Einstein's attitude and that of the opponents of relativity theory..." (*ibid.*, p. 418). At the same congress, Ehrenfest had another opportunity to put all the confusion into perspective. As Clark reports: "...Lorentz did his best to give the floor to only one speaker at a time. But everyone felt strongly. Everyone wanted to put his own view. There was the nearest thing to an uproar that could occur in such distinguished company, and in the near confusion Ehrenfest moved up to the blackboard which successive speakers had used and wrote on it: 'The Lord did there confound the language of all the Earth'" (*ibid.*, p. 417).

Heisenberg: “We cannot observe electron orbits inside the atom...Since a good theory must be based on observable magnitudes, I thought it more fitting to restrict myself to these, treating them, as it were, as representatives of the electron orbits.”

Einstein: “But you don’t seriously believe that none but observable magnitudes must go into physical theory?”

Heisenberg: “Isn’t that precisely what you have done with relativity?”

Einstein: “Possibly I did use this kind of reasoning, but it is nonsense all the same...In reality the very opposite happens. It is the theory which decides what we can observe.”⁸⁶⁷

With that interesting look into the methodology of Einstein, the saga continues:

The distressing position in which Einstein now found himself was not unique. J. Robert Oppenheimer has pointed out how ‘many of the men who have contributed to the great changes in science have really been very unhappy over what they have been forced to do, and cites not only Planck and Einstein but Kepler and de Broglie. The process is not restricted to physics. Lord Conway...has pointed out that “each generation makes of the world more or less the kind of place they dream it should be, and each when its day is done is often in a mood to regret the work of its own hands and to praise the conditions that obtained when it was young.”⁸⁶⁸

So with Einstein. At times he was wryly humorous about his inability to accept the new world which his colleagues had created. Philipp Frank visited him in Berlin, apparently in 1932, and they began to talk of the new physics. Then, says Frank, ‘Einstein said, partly as a joke, something like this: “A new fashion has now arisen in physics. By means of ingeniously formulated theoretical experiments it is proved that

⁸⁶⁷ *Physics and Beyond*, translated by Arnold J. Pomerans, New York: Harper, 1971, p. 63. Original in German is titled *Der Teil und das Ganze*, München: Piper, 1969, S. 79-80. Einstein’s quote (“It is the theory which decides what we can observe”) seems to be well known, since it was quoted in *Discover’s* April 2004 issue, page 14, although without a reference. Heisenberg also writes of Einstein: “Bohr and Einstein were in the thick of it all. Einstein was quite unwilling to accept the fundamentally statistical character of the new quantum theory” (Werner Heisenberg, *Physics and Beyond*, 1971, p. 79).

⁸⁶⁸ *Ibid.*, pp. 413-414.

certain physical magnitudes cannot be measured, or, to put it more precisely, that according to accepted natural laws the investigated bodies behave in such a way as to baffle all attempts at measurement. From this the conclusion is drawn that it is completely meaningless to retain these magnitudes in the language of physics. To speak about them is pure metaphysics.”⁸⁶⁹

And then Einstein was hit with the proverbial mirror to see his own reflection:

And when Frank pointed out to Einstein that he had invented the fashion in 1905, Einstein answered: ‘A good joke should not be repeated too often.’ More cogently, he explained to Infeld – the Pole who had visited him in Berlin and who was later to join him in the United States – ‘Yes, I may have started it, but I regarded these ideas as temporary, I never thought that others would take them so much more seriously than I did.’⁸⁷⁰

Einstein’s facile attempt at deflecting the blame away from himself is certainly disturbing. Perhaps he is trying to pass off his theory of Relativity as just an exercise in free-thinking, as even his famous “thought experiments” belie; or that, when his theories are found to lead to absurdities, we simply pull the plug and call it all a joke. What kind of man would pardon himself by suggesting that men subsequent to him shouldn’t have taken the implications of his theories so seriously? In fact, the great Indian astrophysicist, Subrahmanyan Chandrasekhar was said to have a “deep anger” at Einstein for not sufficiently developing his theories and consequently leaving the struggle to others.⁸⁷¹ Perhaps in line with his above comment to Heisenberg (“It is the theory which decides what we can observe”), Einstein’s following comment probably makes more sense: “When I examine myself and my methods of thought I come to the conclusion that the gift of fantasy has meant more to me than my talent for absorbing positive knowledge.”⁸⁷² Unfortunately, it is precisely these “fantasies” that have turned the world upside down. To those who are looking to get out from the quagmire into which Einstein and modern physics have put the world, his words are indeed no “joke,” especially for those of us who realize that Einstein’s *Trojan Horse* was created in 1905 precisely to escape the clear and numerous experimental

⁸⁶⁹ *Ibid.*, p. 414.

⁸⁷⁰ *Ibid.*, p. 414.

⁸⁷¹ Interview of Dr. Chandrasekhar by Lee Smolin, cited in *Discover*, September 2004, p. 39.

⁸⁷² *Einstein: Life and Times*, p. 87 in 1971 edition.

results showing that ether existed and that the Earth was standing still in it. Almost all the absurdities of modern physics have their root in the “fantastic” interpretations Einstein gave to those crucial experiments.

Thus we see, like many men before him whose limited perspective led them to question the validity of their own theories, so Einstein was faced with the same. It was the inevitable result of his theory, for Relativity makes all understanding just that – relative – with no certainty and no absolutes. Einstein could not live with his own theory, and, as we have documented, at many points he found himself retracing his steps and reviving the very concepts that he had originally denied.

Newton's Absolute Space and the Spinning Water Bucket

As we noted, Einstein felt compelled to come closer to Newton's idea of "absolute space," and thus he returned to the ether concept. Einstein's appeal to Newton stems from the problem Newton discovered concerning the "[spinning bucket of water](#)." Although Newton did not make any definitive claims as to the constitution of space, nevertheless, as opposed to Einstein, he believed it was absolute, that is, space had an existence separate from the matter contained within it and independent of the arbitrary perceptions of Einstein's "observer." As he states it: "Absolute space, in its own nature, without regard to anything external, remains always similar and immovable."⁸⁷³ Space never changed, no matter what event occurred in it or who observed that event. We know this postulate in modern terms as "the inertial frame of reference."

Newton was led to his particular understanding, and attempted to prove it, by the experiment of the spinning bucket of water. Here is how the 1689 experiment was conducted: Newton hung a bucket of water by a rope. He turned the bucket so the rope was wound up very tightly, and then he allowed the bucket to unwind. As the bucket spun, the water level, which was previously flat, gradually started to curve up the sides of the bucket. In all such experiments, as the water begins to rotate at the same speed as the bucket, the surface of the water becomes concave. Here Newton had a keen insight. When the bucket started to move against the water, the water level was flat. It was only when water was moving with the bucket that the surface of the water began to curve upwards. As Newton puts it:

...the surface of the water will at first be plain [flat], as before the vessel began to move; but the vessel, by gradually communicating its motion to the water, will make it begin sensibly to revolve, and recede little by little from the center, and ascend up the sides of the vessel, forming itself into a concave figure (as I have experienced), and the swifter the motion becomes, the higher will the water rise, till at last, performing its revolutions in the same time with the vessel, it becomes relatively at rest in it.⁸⁷⁴

Newton reasoned that it was not the bucket that changed the shape of the water's surface, that is, it was not the inside of the bucket that was attracting the water. Once the surface of the water curved

⁸⁷³ Isaac Newton, *Philosophiae Naturalis Principia Mathematica*, Bk. 1 (1689); translated by Andrew Motte (1729), revised by Florian Cajori, Berkeley: University of California Press, 1934, Definition VIII.

⁸⁷⁴ Isaac Newton, *Philosophiae Naturalis Principia Mathematica*, Bk. 1 (1689); translated by Andrew Motte (1729), revised by Florian Cajori, Berkeley: University of California Press, 1934, Definition XII.

upward, the bucket's only function was to contain the water in a confined space. If one suddenly stops the spinning bucket the surface of the water will remain concave as long as the water's velocity continues. Newton reasoned that it was something about the nature of rotation itself that causes this phenomenon.

Although this experiment seems simple and ordinary, it has spawned some of the most perplexing scientific and philosophical questions man has ever faced. Using a little personification to help understand the perplexity of this phenomenon, the question would be posed: how does the water know that it is rotating and that it should form a curved surface? If the sides of the bucket are not creating the phenomenon except to confine the water to one place, then against what is the water spinning and curving? Of course, being in the wake of Copernicus, Newton considered it unimaginable that a rotating universe against a fixed Earth could be responsible for causing the water to curve upward, and thus he concluded that the water must be reacting to a fixed space surrounding it, and in that sense the water's motion was not relative but absolute. But in Newton's view, absolute space is more of a concept than a real entity with physical locus points. As such, the water's curve upward could not be caused by rotation in relation to absolute space. Hence Newton, by his own admission, admitted he did not know why a rotating object should react in this way with absolute space. Instead, the label "centrifugal force" was employed to describe the phenomenon, but neither Newton nor anyone else could explain its real origin or nature.

Newton tried a variation of the experiment, but this time it was a thought experiment. He envisioned two balls tied together with a rope. On Earth, if the balls are rotated around a common center, the rope will become taut as the balls recede from one another. But what would happen if the balls were rotated in an empty universe? As Newton puts it:

For instance, if two globes, kept at a given distance one from the other by means of a cord that connects them, were revolved about their common center of gravity, we might, from the tension of the cord, discover the endeavour of the globes to recede from the axis of their motion, and from thence we might compute the quantity of their circular motions....And thus we might find both the quantity and the determination of this circular motion, even in an immense vacuum, where there was nothing external or sensible with which the globes could be compared. But now, if in that space some remote bodies were placed that kept always a given position one to another, as the fixed stars to in our regions, we could not indeed determine from the relative translation of the globes among those bodies,

whether the motion did belong to the globes or to the bodies...⁸⁷⁵

Although Newton says he will provide us the reason for this phenomenon (he writes: “it shall be explained more at large in the following tract”), except for his reasoning that rotational motion created a force when it moved against absolute space, he did not provide a physical answer to the phenomenon, but merely mathematical equations that calculated the amount of the forces involved. Thus, as he had earlier admitted:

It is indeed a matter of great difficulty to discover, and effectually to distinguish, the true motions of particular bodies from the apparent; because the parts of that immovable space, in which those motions are performed, do by no means come under the observation of our senses.⁸⁷⁶

As we will see when we cover the subsequent history, the common thread running through all the attempts from Newton onwards to explain the water bucket experiment, and to explain the difference between absolute and relative motion, all stem from the problem they inherited from Copernicus, the man who took away the one absolute they possessed – an immobile Earth. On the one hand, they were all somewhat inebriated by the sense of freedom Copernicus brought to them, for in their words, he had unshackled the world from the grip of medieval philosophy and theology. Like the teenager who has his taste of freedom running away from home but soon discovers how lost and desperate he is as he tries to figure out life on his own, so the sons of the Enlightenment found themselves in the same predicament when they tore themselves away from the arms of their holy mother. There was simply no place to put an anchor any longer. Copernicus had cut the umbilical cord, and men were now floating in space. From then onward, science and philosophy become little more than one attempt after another to restore Earth’s moorings, but they tried to do so without giving up the Copernican theory – a formidable task, indeed.

⁸⁷⁵ Isaac Newton, *Philosophiae Naturalis Principia Mathematica*, Bk. 1 (1689); translated by Andrew Motte (1729), revised by Florian Cajori, Berkeley: University of California Press, 1934, Definition XIV.

⁸⁷⁶ Isaac Newton, *Philosophiae Naturalis Principia Mathematica*, Bk. 1 (1689); translated by Andrew Motte (1729), revised by Florian Cajori, Berkeley: University of California Press, 1934, Definition XIV.

The “Space” of Diggs, Bruno and Descartes

Thomas Digges (d. 1595) made it even more difficult. Two decades after Copernicus, Digges observed a “new star” in the cosmos and wrote about it in his work *Alae seu scalae mathematicae*. (This “star” was the same supernova that Tycho Brahe had discovered in 1572). From this discovery, Digges proposed a modified universe to that of Copernicus, suggesting that the expanse of space was not closed but infinite, and that the sun and planets were located in a remote and isolated part of the cosmos. Although his father, Leonard Digges, held to the Ptolemaic model, Thomas Digges was a staunch leader of the Copernicans in England. In 1576 he added an appendix to his father’s 1556 almanac, *A Prognostication Everlasting*, which supported the Copernican theory under the title: *A Perfit Description of the Caelestiall Orbes according to the most aunciente doctrine of the Pythagoreans, latelye revived by Copernicus and by Geometricall Demonstrations approved*. This was the first English publication supporting the Copernican theory, comprised mainly of an English translation of the main chapters of Copernicus’ book, *De revolutionibus*.

Right on the heels of Digges was [Giordano Bruno](#) (d. 1600), the person whom the Inquisition is alleged to have executed both for his heretical ideas and his insistence that the Church should not dictate truth.⁸⁷⁷ Bruno defended Copernican cosmology in the book *La Cena de*

⁸⁷⁷ Among Giordano’s more heretical ideas was pantheism, although he later rejected it for a more deterministic system in which “graded animate monads” were given some independence from the “informing” Source. He believed the “transcendent God” is known by faith, but the immanent is reflected in numerous animate unities that constitute reality. Bruno had a great influence on Spinoza, Leibniz and Descartes (*Encyclopedia of Religion*, p. 90). The work that brought Bruno before the Inquisition was *Spaccio de la Destia Trionphante*, which “attacked all religions of mere credulity as opposed to religions of truth and deeds” (Dorothy Stimson, *The Gradual Acceptance of the Copernican Theory*, p. 50, from J. Lewis McIntyre, *Giordano Bruno*, London, 1903, pp. 16-40). It was a biting attack on the Roman Church. At the time, Bruno was in England, living at the same time as William Shakespeare (Robert Beyersdorf, *Giordano Bruno and Shakespeare*, Leipsic, 1889, pp. 8-36), but Shakespeare was a firm geocentrist, as noted in such passages as *Troilus and Cressida*, Act 1, scene 3; *King John*, Act III, scene 1; and *Merry Wives*, Act III, scene 2 (Stimson, *ibid.*), and he was a devout Catholic as well. Frances Yates, the Oxford scholar, investigated the original manuscripts at the Warburg Institute in London and determined that, based on the heliocentric theory, Bruno believed he could call down power from the sun. The Inquisition discovered that his plan was to reconcile Catholics and Protestants by recourse to Egyptian Sun-worship (and associated with the Greek god, Hermes). Bruno also sought the use of magic and astrally empowered images to achieve this goal. The Freemasons and Kabbalistic Jews of the French Revolution idolized Bruno and carried his bust in street processions. Yates shows that much of Renaissance and Post-Renaissance science was based on magic and the occult. Yates also believed Bruno was executed, although she admits there is no official Vatican record of it (Frances A. Yates, *Giordano Bruno and the Hermetic Tradition*, University of Chicago Press, 1964, 1991, p. 349). Despite Yates’ belief, there is substantial evidence leading to the

la Ceneri,⁸⁷⁸ and developed his concept of an infinite universe in *De l'Infinito e Mondi* ("On the Infinite Universe and Worlds") and *De Immenso et Innumerabilis*. ("On the Immense and the Innumerable").⁸⁷⁹ Whereas Copernicus' universe was much bigger than Ptolemy's and Aristotle's, it was finite, since it was enclosed within the sphere of fixed stars. Yet Copernicus' model would inevitably lead to an infinite universe, mainly because it had no center, but also because, as Koestler says, "once the apparent daily round of the firmament was explained by the Earth's rotation, the stars could recede to any distance,"⁸⁸⁰ and the more difficult it would be for the geocentrists to explain how an immense universe could rotate. With this implication, Bruno declared that Earth was merely a planet, and, sounding a bit like a modern String theorist or a forerunner of the "omega-searching" Teilhard de Chardin influenced by the "noosphere," Bruno held that:

...this world itself was merely one of an infinite number of particular worlds similar to this, and that all the planets and other stars are infinite worlds without number composing an infinite universe, so that there is a double infinitude, that of the

conclusion that Bruno was never executed, least of all by Catholic authorities. According to one source: "The whole story is based on an alleged letter from Gaspard Schopp to his friend Conrad Rittenshausen, dated in Rome, Feb. 17, 1600... This letter was 'found' by a Lutheran pastor, Jean-Henri Ursin (1608-1667) in a book printed in Germany, a very rare book with a pseudonym for the author, as well as a false date and place of publication. No one has ever seen the original letter.... No contemporary of Bruno's in Rome in 1600 ever mentioned an execution. Bruno was very famous throughout Europe, and his death, especially at the stake in Rome, would not go unnoticed, particularly by Protestant authors who would certainly have been all too happy to denounce Catholic intolerance. Moreover, there is absolutely no record of a trial or of any sentence against Bruno. All that is known is, after spending six years (1592-1598) in Venetian jails, Bruno came back to Rome. He might have been put under house arrest in some monastery, but no one knows how he died. Strangely enough, it is only from 1701 onwards that the story of Giordano Bruno made headlines, without any new evidence about his fate.... Pierre Bayle (1647-1706) the famous author of the *Dictionnaire historique et critique*... in his article on Bruno says he does not believe he was executed since the only source is Schopp's letter, which he considers a fake. In addition, Moreri (1643-1680), who wrote the *Grand Dictionnaire Historique*, does not believe Bruno was executed. Last but not least, the Venetian ambassadors in their diplomatic dispatches to the government never mentioned an execution of Bruno, yet he spent six years in their jails" (Source: Claude Eon, letter on file, November 2005).

⁸⁷⁸ *La Cena de le Ceneri* in *Opere Italiano*, ed., Gentile, Bari 1907.

⁸⁷⁹ *De Immense et Innumerabilis*, in *Opera Latina Conscripta*, ed., Fiorentino, Naples, 1884, Libero III, cap. 9, vol. 1, pt. 1. 380-386, cited in Stimson, p. 51.

⁸⁸⁰ *The Sleepwalkers*, p. 220.

greatness of the universe, and that of the multitude of worlds.⁸⁸¹

These bizarre ideas were part of Bruno's "astro-theology," which greatly alarmed Church officials, who eventually had him extradited to Rome to face this and other incidents of heretical teaching.

Having isolated the Earth in the far away corners of space, [René Descartes](#) (d. 1650) attempted to at least apply a leash to the remaining cosmos by introducing his famous saying *Cogito ergo sum* ("I think therefore I am"). Once one forsakes his home, he will need a new start in life, an identity of his own, and what better identity could there be than the human cognition that caused the separation? Having picked himself up by his own bootstraps, he also needed a new home, an anchor to secure himself, and this Descartes solved by inventing the "Cartesian coordinates." Instead of a sphere, the universe was now dissected into x, y, z coordinates, just as if one were to measure the length, width and height of a room from one of its corners. If one wants to locate a certain position within the room, he simply finds the place where the three coordinates intersect. The problem with this system is, of course, without an immobile Earth, Descartes was at a loss to tell us where the universe's "corner" is located. Thus Descartes was led to believe that space didn't exist, rather, he believed space is made up of bodies themselves and their extensions. What we see as empty space is actually filled with bodies, small or large, and there is no place in the universe where a body does not exist. As such, when one measures "space" he is measuring the bodies which are compacted together, and out of which the Cartesian coordinates possess their intrinsic dimensions.⁸⁸²

⁸⁸¹ William Roscoe Thayer, *Throne Makers*, New York, 1899, p. 268, from *Giordano Bruno: His Trial, Opinions and Death*, pp. 252-308, cited in Stimson, p. 51.

⁸⁸² René Descartes, *Die Prinzipien der Philosophie*, ed. A. Buchenau, Philosophische Bibliothek, Vol. 28 (F. Meiner, Hamburg, Germany, 1992).

The “Space” of Leibniz, Euler and Kant

Wilhelm Leibniz (d. 1716) came after Descartes and told a different story. His idea was that the space between the bodies sufficed for a definition of space. But since he also did not possess a central and immobile Earth, Leibniz was forced to say that no location of any object in space is in distinction to any other location. As such, there is no reason to speak of objects being located in certain places, and thus he also rejected Newton’s concept of absolute space, since “absolute” implies that two or more locations can be distinguished. Newton’s water bucket experiment did, however, present a problem to Leibniz. In his correspondence with Samuel Clarke, Leibniz admitted he had no answer to it:

I find nothing in the Eighth Definition of the *Mathematical Principles of Nature*, nor in the Scholium belonging to it, that proved, or can prove, the reality of space in itself. However, I grant there is a difference between an absolute true motion of a body, and a mere relative change of its situation with respect to another body. For when the immediate cause of the change is in the body, that body is truly in motion; and then the situation of other bodies, with respect to it, will be changed consequently, though the cause of the change be not in them. ‘Tis true that, exactly speaking, there is not any one body, that is perfectly and entirely at rest; but we frame an abstract notion of rest, by considering the thing mathematically. Thus have I left nothing unanswered, of what has been alleged for the absolute reality of space. And I have demonstrated the falsehood of that reality, by a fundamental principle, one of the most certain both in reason and experience; against which, no exception or instance can be alleged. Upon the whole, one may judge from what has been said that I ought not to admit a moveable universe; nor any place out of the material universe.⁸⁸³

Here we note Leibniz’s comment: “‘Tis true that, exactly speaking, there is not any one body, that is perfectly and entirely at rest; but we frame an abstract notion of rest, by considering the thing mathematically” is stating the precise problem that Copernicus left the world after his insistence that the Earth was moving in space.

Newton, as we have noted, used the water bucket experiment to attempt to prove the existence of absolute space, but he could neither explain the specific property space possessed that would allow it to pull up water, nor did he demonstrate how absolute space could be directly

⁸⁸³ Leibniz-Clarke Correspondence, 5th paper, Manchester University Press, England, 1956.

observed. Although it can be said that Newton may have stumbled onto an alternative answer in his comment: “as the fixed stars do in our region,”⁸⁸⁴ the precise contribution the stars made to the matter would not be suggested until about two hundred years later in the work of [Ernst Mach](#), and then immediately thereafter by Albert Einstein. Prior to that, [George Berkeley](#) had suggested that the water in the bucket was rotating not with respect to absolute space but to the stars, but at that time no one was apt to listen to challenges to Newton’s view of the universe.

Next on the scene was [Leonhard Euler](#) (d. 1783). He insisted that absolute space and absolute time are beyond much doubt, since these two components are compatible with observation, and therefore they are real, not imaginary. To Euler it made sense that merely imagining absolutes cannot serve as the basis for celestial mechanics, or for that matter, any mechanics. As such, Euler neither accepted Berkeley’s suggestion that the stars are the absolute frame of reference nor the source that controlled the laws of inertia, since such star-power was considered “metaphysical,” not mechanical.⁸⁸⁵

[Immanuel Kant](#) (d. 1804) succeeded Euler. Using a bit of metaphysics, he concluded that space and time are *a-priori* elements of existence since, if we measure things in space and time, without them we would have no experience. Space and time thus become pristine forms of human intuition and, therefore, cannot be altered by experience. But this particular version of space and time is absolute, and must be distinguished from empirical space and time, the latter of which is a matter of perception, yet constitutes all the objects we experience. This formulation, of course, goes hand-in-hand with Kant’s philosophical separation of the noumenal world (i.e., “the thing in itself”) from the phenomenal world (i.e., the world known through experience), a philosophy that marked the beginning of the end for the Enlightenment, for man could no longer be certain that the things he experienced were real since they could just as well be a figment of his imagination.

Kant admitted, however, that circular motion, as opposed to uniform linear motion, is real motion in itself, since it presupposes the existence of an external force that prohibits the body from moving in a straight line. (This coincides with Newton’s First Law of motion concerning inertia, which, opposed to Aristotle’s view, did not require a force to keep the body moving in a linear direction). From this reasoning, Kant makes his defense of Copernicanism. For him, it is not merely an “experiential” matter that the Earth rotates among fixed stars as opposed

⁸⁸⁴ Isaac Newton, *Philosophiae Naturalis Principia Mathematica*, Bk. 1 (1689); translated by Andrew Motte (1729), revised by Florian Cajori, Berkeley: University of California Press, 1934, Definition XIV.

⁸⁸⁵ Leonhard Euler, “Réflexions sur l’espace et le temps,” *Memoir de l’academie des sciences de Berlin* 4, 324, 1748.

to the stars revolving around a fixed Earth, since according to Kant real motion can be demonstrated empirically by the presence of inertial forces.⁸⁸⁶ Kant, of course, was never exposed to the ideas of Ernst Mach, otherwise he would have known that inertial forces in space are just as relative as everything else, that is, without a fixed Earth to decide the issue.

It is significant that Kant concludes his analysis of the problem of motion by asserting that the Copernican theory was correct. It shows that upholding Copernicanism was at the forefront of the debate, although it was somewhat camouflaged by all the discussion concerning “absolute” versus “relative.” The truth is that the sons of the Enlightenment were in quite a predicament trying to make sense of a universe in which everything was moving, thus causing the relations between objects to become very confusing. They were caught, on the one hand, trying to avoid the “unthinkable” (the immobile Earth the ancients had bequeathed to them) and, on the other hand, trying to salvage from this confusion their own “absolutes.” Rejecting the Earth as the absolute, Descartes postulated his “Cartesian coordinates,” Leibniz his “defined” space, Berkeley his “stars,” Euler his “absolute space and time,” Newton his “absolute space,” and Kant his “circular motion,” in order to fill the gapping hole left by Copernicus. None of these worked, however, and, in fact, the whole affair eventually produced the philosophical and mechanical schizophrenia latent in Kantianism.⁸⁸⁷

After Kant’s wrecking ball, the world has never been quite the same. Men wandered around as philosophical zombies not knowing what was real and what was fantasy. It was just a matter of time before the relativistic world of Albert Einstein would serve as the nuclear bomb, as it were, to obliterate any attempt to revive an immobile Earth. But as the saying goes: ‘what goes around, comes around,’ for, inadvertently, it was the very theory of Relativity that breathed life back into the corpse of geocentrism since, by the very tenets of Relativity, Einstein proved there was no way to discount geocentrism. In other words, the very wall that they all sought to avoid was the precise one into which they all ran.

⁸⁸⁶ Immanuel Kant, “Metaphysische Anfangsgründe der Naturwissenschaft,” *Schriften zur Naturphilosophie*, Werkausgabe Band IX, ed., W. Weischedel, Suhrkamp, Frankfurt, 1968.

⁸⁸⁷ Interestingly enough, Kant didn’t think too highly of Newton’s view of the universe. He writes: “Newton’s dynamics goes essentially beyond all observations. It is universal, exact and abstract; it arose historically out of myths; and we can show by purely logical means that it is not derivable from observation-statements” (cited in Karl Popper’s, *Conjectures and Refutations*, p. 190). Popper adds: “Kant also showed that what holds for Newtonian theory must hold for everyday experience...that everyday experience, too, goes far beyond all observation. Everyday experience too must interpret observation; for without theoretical interpretation, observation remains blind – uninformative. Everyday experience constantly operates with abstract ideas, such as that of cause and effect, and so it cannot be derived from observations” (*ibid.*).

Ernst Mach, Albert Einstein and Modern Philosophy

Before we analyze Mach's and Einstein's solutions to Newton's bucket problem, it would be beneficial to investigate their relationship. Of all scientists, [Ernst Mach](#) probably had the greatest influence on Einstein. Even though they would eventually diverge on several key points, according to Holton, "until Mach's death, and for several years after, Einstein declared himself a disciple of Mach." Mach was an Austrian physicist, physiologist and psychologist, and he tried to understand reality through a synthesis of each of these disciplines. Moritz Schlick was one of his closest adherents and describes Mach's methodology in these words:

Since all our testimony concerning the so-called external world relies only on sensations, Mach held that we can and must take these sensations and complexes of sensations to be the sole contents [Gegenstände] of those testimonies, and, therefore, that there is no need to assume in addition an unknown reality hidden behind the sensations...there exists in this world nothing whatever other than sensations and their connections...scientific knowledge of the world consists, according to Mach, in nothing else than the simplest possible description of the connection between the elements [sensations]...⁸⁸⁸

One who is familiar with philosophy will see definitive elements of both Kant and Hume in Mach's approach. Kant more or less limited our understanding of reality to the categories of the mind obtained by *a priori* intuition, as opposed to the objectiveness of the thing in itself; and Hume believed that nothing could be known except by sense experience.

Michele Besso, Einstein's oldest and closest friend, had introduced him to the work of Mach. Interestingly enough, although a victim of the Copernicanism and Newtonianism he inherited, Mach was on a continual search for at least some kind of absolute. He knew instinctively, as most physicists do, that this void had to be filled. It's quite unfortunate that they all turned their back on the fixed-Earth given to them by Christianity. Instead,

Mach suggested referring all motion to the fixed stars (as in his well-known analysis of Newton's bucket experiment), or perhaps to a "medium" filling all of space (i.e., ether), or to a mean velocity with respect to all the masses in the universe.⁸⁸⁹

⁸⁸⁸ Moritz Schlick, *Ernst Mach, der Philosoph*, in a special supplement on Ernst Mach in the *Neue Freie Presse*, Vienna, June 12, 1926, as cited in Holton, *Thematic Origins of Scientific Thought*, p. 240.

⁸⁸⁹ *Albert Einstein's Special Theory of Relativity*, p. 121.

Mach's books: *Science of Mechanics*, *The Principles of Physical Optics* and *Analysis of Sensations* had the greatest initial effect on Einstein.⁸⁹⁰ In the first book were two ideas that helped mold Einstein's thinking. First...

by Einstein's insistence from the beginning of his relativity paper that the fundamental problems of physics cannot be understood until an epistemological analysis is carried out, particularly so with respect to the meaning of the conceptions of space and time; and second, by Einstein's identification of reality with what is given by sensations, the "events," rather than putting reality on a plane beyond or behind sense experience.⁸⁹¹

Since Kant had created a deep chasm between our subjective thinking and the objective nature of reality, gone forever were the absolutes of Greek and Medieval thought. Whereas a balance existed in pre-Kantian times between nature and grace, after Kant, grace had all but been obliterated from man's thought process. The phenomenal world of particulars was likewise separated from the noumenal world of universals. From this, a movement toward determinism soon became prominent, first in physics and then in human disciplines, such as psychology, sociology and biology. As Arthur Miller states:

Einstein no doubt found this book provocative....All of this discussion was based upon a framework whose dynamics were explained more clearly than by Hertz or von Helmholtz – that is, the neo-Kantian framework emphasizing the role of those organizing principles for thinking which admit of the validity, for example, of non-Euclidean geometrics.⁸⁹²

As [Karl Popper](#) summed it up so well:

In Kant's own striking formulation of this view, 'Our intellect does not draw its laws from nature, but imposes its laws on nature.' This formula sums up an idea which Kant himself proudly calls his 'Copernican Revolution.' As Kant puts it, Copernicus, finding that no progress was being made with the theory of the revolving heavens, broke the deadlock by turning

⁸⁹⁰ As Einstein stated in his *Autobiographical Notes* of 1946: "This book exercised a profound influence upon me....I see Mach's greatness in his incorruptible skepticism and independence; in my younger years, however, Mach's epistemological position also influenced me very greatly....As far as the history of science is concerned, it appears to me that Mach stands at the center of the development of the last 50 or 70 years" (p. 21).

⁸⁹¹ Holton, *Thematic Origins of Scientific Thought*, p. 242.

⁸⁹² *Albert Einstein's Special Theory of Relativity*, p. 121.

the tables, as it were: he assumed that it is not the heavens which revolve while we the observers stand still, but that we the observers revolve while the heavens stand still. In a similar way, Kant says, the problem of scientific knowledge is to be solved – the problem how an exact science, such as Newtonian theory, is possible, and how it could ever have been found. We must give up the view that we are passive observers, waiting for nature to impress its regularity upon us. Instead we must adopt the view that in digesting our sense-data we actively impress the order and the laws of our intellect upon them. Our cosmos bears the imprint of our minds.

By emphasizing the role played by the observer, the investigator, the theorist, Kant made an indelible impression not only upon philosophy but also upon physics and cosmology. There is a Kantian climate of thought without which Einstein's theories or Bohr's are hardly conceivable; and Eddington might be said to be more of a Kantian, in some respects, than Kant himself.⁸⁹³

Popper then posits that the Kantian methodology applied the salve to the wound caused by Copernicanism:

There is a second and even more interesting meaning inherent in Kant's version of the Copernican Revolution, a meaning which may perhaps indicate an ambivalence in his attitude towards it. For Kant's Copernican Revolution solves a human problem to which Copernicus' own revolution gave rise. Copernicus deprived man of his central position in the physical universe. Kant's Copernican Revolution takes the sting out of this. He shows us not only that our location in the physical universe is irrelevant, but also that in a sense our universe may well be said to turn about us; for it is we who produce, at least in part, the order we find in it; it is we who create our knowledge of it. We are discoverers: and discovery is a creative art.⁸⁹⁴

By the time Einstein came on the scene, a "creative art" is precisely what the scientific endeavor became. Man now visualized himself riding on moonbeams, growing older than his twin brother, and seeing matter shrink when it moved. Once Kant opened the floodgates, man could, in an almost god-like fashion, impose his thoughts on the universe and mold it anyway he saw fit, backed up, of course, with mathematical equations that gave it a veneer of credibility.

⁸⁹³ *Conjectures and Refutations: The Growth of Scientific Knowledge*, pp. 180-181.

⁸⁹⁴ *Conjecture and Refutations*, p. 181.

With the additional philosophies of Hegel, Heidegger, and a few other German and French philosophers, scientific thinkers of Ernst Mach's breed were commonplace in Europe. In fact, the whole concept of "relativity" sprung out of this crucible. Einstein's 1905 paper, which converged on many fronts with Mach's philosophical ideas was, according to Holton,

...enthusiastically embraced by the groups who saw themselves as philosophical heirs of Mach, the Vienna Circle of neopositivists and its predecessors and related followers, [relativity] providing a tremendous boost for the philosophy that had initially helped to nurture it. A typical response welcoming the relativity theory as "the victory over the metaphysics of absolutes in the conceptions of space and time...a mighty impulse for the development of the philosophical point of view of our time," was extended by Joseph Petzoldt in the inaugural session...in Berlin, 11 November 1912.⁸⁹⁵

Hence, we see that this was a philosophical war. The "victory over the metaphysics of absolutes" was the battle cry against the Aristotelian and Platonic ideals that had permeated classical thought and helped give philosophical structure to Christian thought in the work of Augustine and Aquinas. This is precisely why the issue of whether the Earth is the immobile center of the universe is so vitally important, and which these "neopositivists" understood all too well. Once Copernicus, Kepler, Newton, and now Einstein, had removed that universal absolute, no one could stand in the way of the philosophical juggernaut that would issue from it. When the results from Arago, Airy, Fizeau, and Michelson-Morley threatened to pop the bubble of "victory over absolutes" (since they demonstrated physical evidence of the likelihood that Earth was fixed in space), we can understand why Einstein became such a revered icon of modern man. With or without Mach, he saved them from a fate worse than death. With Einstein's magic, the Earth would remain moving.⁸⁹⁶

⁸⁹⁵ *Thematic Origins of Scientific Thought*, p. 243.

⁸⁹⁶ Ironically, Mach rejected the Special Theory of Relativity based on the fact that it was not founded on empirical evidence. Mach writes in 1913: "I gather from the publications which have reached me, and especially from my correspondence, that I am gradually becoming regarded as the forerunner of relativity...I must, however, as assuredly disclaim to be a forerunner of the relativists as I personally reject the atomistic doctrine of the present-day school, or church" (*ibid.*, p. 248). Einstein laments: "The theory was, for him, inadmissibly speculative. He did not know that this speculative character belongs also to Newton's mechanics, and to every theory [of] which thought is capable. There exists only a gradual difference between theories, insofar as the chains of thought from fundamental concepts to empirically verifiable conclusions are of different lengths and complications" (From *Zur Enthüllung von*

Mach's Interpretation of Newton's Bucket

Now we are ready for Mach's interpretation of the "bucket" experiment. Since Mach held that all knowledge was derived from sensation, he refused to accept any postulate of natural science that was not verified empirically. This prompted him to deny Newton's concept of absolute space. He writes:

The one experiment [Newton's bucket] lies before us, and our business is, to bring it into accord with the other facts known to us, and not with the arbitrary fictions of our imagination."⁸⁹⁷

He argued, rather, that as the water curved upwards inside the bucket it was reacting to all the mass surrounding it, including the Earth and the stars. Whereas Newton said the water was rising relative to absolute space and that the observer witnessed the event with absolute space as his foundation, Mach said the water was rising relative to external mass and that the observer viewed the event with the external mass as his foundation. In doing so, Mach obviously rejected absolute space as the foundation. He writes:

Newton's experiment with the rotating water bucket teaches us only that the rotation of water relative to the bucket walls does not stir any noticeable centrifugal forces; these are prompted, however, by its rotation relative to the mass of the Earth and the other celestial bodies.⁸⁹⁸

Mach's general point is that, since Newton fixated on absolute space, he did not take into account relative motion, that is, the water was rotating relative to all the matter in the universe such that if there were no other matter, the water surface would not become concave. Mach also discounted Newton's thought experiment concerning the two globes, stating that if there were no universe against which the globes would rotate, we would not know that the globes were rotating.

Ernst Machs Denkmal, n. 13, as cited in *Thematic Origins of Scientific Thought*, p. 250).

⁸⁹⁷ Ernst Mach, *The Science of Mechanics: A Critical and Historical Account of its Development*, published 1883, trans., T. J. Macormack, La Salle, Open Court, 1960, p. 284.

⁸⁹⁸ Ernst Mach, *The Science of Mechanics: A Critical and Historical Account of its Development*, published 1883, translated by T. J. Macormack, La Salle, Open Court, 1960, p. 284. Mach further pointed out that if the water in the bucket was "several leagues thick" and thus of great mass itself, we could not predict how it would respond to the mass outside of it.

In another work relating to Newton's bucket experiment, Mach says something that reflects deeply on the geocentric issue:

Obviously, it doesn't matter if we think of the Earth as turning round on its axis, or at rest while the fixed stars revolve round it. Geometrically these are exactly the same case of a relative rotation of the Earth and the fixed stars with respect to one another. But if we think of the Earth at rest and the fixed stars revolving round it, there is no flattening of the Earth, no Foucault's experiment, and so on – at least according to our usual conception of the law of inertia. Now one can solve the difficulty in two ways. Either all motion is absolute, or our law of inertia is wrongly expressed. I prefer the second way. The law of inertia must be so conceived that exactly the same thing results from the second supposition as from the first. But this it will be evident that in its expression, regard must be paid to the masses of the universe.⁸⁹⁹

Geocentrists, of course, opt for the first of Mach's assured solutions, that is, "all motion is absolute." If the Earth is fixed, all motion is, indeed, absolute, since motion can be measured against one, and only one, absolute point. In any case, Einstein recognized Mach's view in his 1920 paper, stating:

Mach tried to avoid having to accept as real something which is not observable [absolute space] endeavoring to substitute in mechanics a mean acceleration with reference to the totality of the masses in the universe in place of an acceleration with reference to absolute space. But inertial resistance opposed to relative acceleration of distance masses presupposes action-at-a-distance; and as the modern physicist does not believe that he may accept this action-at-a-distance, he comes back once more, if he follows Mach, to the ether, which has to serve as the medium for the effects of inertia.⁹⁰⁰

The geocentrist explains this phenomenon simply: all the matter in the universe is more or less equally distributed around the Earth, and thus its mutual gravitational attraction is canceled at the neutral point, Earth, the center of mass, as required by Newtonian physics. We, however, experience the effect of the universe's collective gravitational force in the form of the phenomenon we know as "inertia." Inertia is the property in which an object remains at rest, or remains in motion if it is already in motion, unless acted upon by a net external force. The rotating

⁸⁹⁹ As cited in William G. V. Rosser's, *An Introduction to the Theory of Relativity*, London, Butterworths, 1964, p. 454, citing from Dennis Sciama's, *The Unity of the Universe*, New York, Anchor Books, 1959.

⁹⁰⁰ 1920 Leyden address, para. 19.

universe creates a ubiquitous and balanced force around the Earth whose primary responsibility is to keep the Earth in place so that it cannot be moved (as the barycenter of a spinning gyroscope remains in place). Since the force is balanced, we do not feel it, unless we move against it (as when we try to turn the gyroscope or suddenly put on the brakes in a moving car). Moreover, the rotation of the universe around the Earth creates the additional forces we understand as centrifugal, Coriolis and Euler forces. These gravitational forces are transmitted (i.e., “action-at-a-distance”) through the universal ether, and we see its differing effects in the various forces we experience (e.g., inertia, centrifugal, etc.). Since the ether is dense and super granular, it can transmit the forces very rapidly. We will address these issues in more detail in coming chapters.

Einstein's Interpretation of Newton's Bucket

As noted previously, the pre-1916 Einstein wanted to dismiss the concept of a “medium” because he thought the Michelson-Morley and similar experiments demonstrated that ether did not exist. As Einstein saw it, if we allow Mach's view that there is inertial resistance between the Earth and the distant stars, then something must carry that resistance, even as air carries sound. Since in Einstein's view there was no difference between inertial resistance and gravitation (which he claimed to have proven by his elevator analogies), he simply replaced Mach's inertial resistance with gravitation. Hence, the Earth was not in inertial resistance against the stars; rather, the Earth was affected, at least partially, by the gravity from the stars. Of course, one might object that Einstein's gravity also needs a “medium” to travel from the stars to the Earth, and thus he does not escape the need for ether. As we noted, Einstein had his particular ways of dealing with this issue. He writes:

According to this theory the metrical qualities of the continuum of space-time differ in the environment of different points of space-time, and are partly conditioned by the matter existing outside the territory under consideration. This space-time variability of the reciprocal relations of the standards of space and time, or, perhaps, the recognition of the fact that “empty space” in its physical relation is neither homogeneous nor isotropic, compelling us to describe its state by ten functions (the gravitational potentials g), has, I think, finally disposed of the view that space is physically empty.⁹⁰¹

Thus, to replace Mach's continuous stream of inertial communication between the stars and the Earth, Einstein proposes that there are pockets of varying gravitational effects all over the universe which are caused both by the objects in the vicinity of the “territory under consideration” (e.g., Earth and the water bucket) and “matter existing outside” (e.g., the distant stars). To what degree the “matter existing outside” affects the “territory under consideration” Einstein does not specify, nor does he explain how such distant matter transmits its effects to Earth, other than to say that there are “ten functions of gravitational potentials,”⁹⁰² which means he will resort to mathematics to explain their existence, not physical evidence.

In any case, Einstein has given us enough information to understand how he will explain Newton's spinning bucket of water.

⁹⁰¹ 1920 Leyden lecture, para. 20.

⁹⁰² These are Einstein's famous “metric tensor fields” or “dimensions of curvature,” a mathematical composite of 20 components (10 of which are independent and 10 of which are zero) that characterize the fabric of space-time in General Relativity.

These distant stars, which can be considered as one massive body, form a universal enclosure around the “territory under consideration,” and, according to General Relativity, they will create space-time dimensions on the bodies within that “territory.” In the case of the bucket, the water climbs the inside walls because, as the water rotates against the masses near it (e.g., Earth, moon, sun, planets) and far from it (e.g., stars, galaxies, black holes), its inertial movement will create a different space-time environment or “gravitational potential” as opposed to what the water had at rest. In a crude sort of way, Einstein posits that the water curves because the space surrounding it curves. Hence, to avoid Mach’s position, Einstein can say that the stars are not *directly* affecting the water, and thus there is no need for a mechanical ether to transmit their force to the water; rather, the stars are only *indirectly* affecting the water by helping to change the space-time dimensions surrounding the water. Since these space-time dimensions do not travel from the stars to the water in the bucket but continually affect space-time dimensions throughout the universe by their ubiquitous existence, then there is no need for what Einstein calls, an “undulating ether” to carry their effects. Thus he concludes:

But therewith the conception of the ether has again acquired an intelligible content, although this content differs widely from that of the ether of the mechanical undulatory theory of light. The ether of the general theory of relativity is a medium which is itself devoid of all mechanical and kinematical qualities, but helps to determine mechanical (and electromagnetic) events.⁹⁰³

⁹⁰³ 1920 Leyden lecture, para. 20. As noted earlier, Einstein candidly admits, however, that his concept of gravitational ether cannot account for electromagnetic activity, since if space is created by gravity, then there is no place for electromagnetic activity to operate independently. This is further complicated by the fact that to Einstein, matter and the electromagnetic field are intimately related, such that matter is “nothing else than condensations of the electromagnetic field” (*ibid*, para. 24). He then says “it would be a great advance if we could succeed in comprehending the gravitational field and the electromagnetic field together as one unified conformation,” but this wish, which he attempted to forge in the Unified Field Theory, never materialized. This failure, of course, suggests that the basic premises of Relativity theory are wrong. In another light, John Wheeler, et al., state: “A model universe that is closed, that obeys Einstein’s geometrodynamics law, and that contains a nowhere negative density of mass-energy, inevitably develops a singularity. No one sees any escape from the density of mass-energy rising without limit. A computing machine calculating ahead step by step the dynamical evolution of the geometry comes to the point where it cannot go on. Smoke, figuratively speaking, starts to pour out of the computer...” (Charles W. Misner, Kip S. Thorne, and John A. Wheeler, *Gravitation*, 1973, p. 1196). Barbour and Bertotti add: “In 1908, Newton’s absolute space and time were replaced by the equally absolute Minkowskian space-time. It is important to note that the local validity of special relativity, however well tested, can no more prove the existence of Minkowskian space-time than the bucket did Newton’s space.” In regard to General Relativity, they state: “To the extent that general relativity, which conceptually is a completely local theory...it is perhaps understandable that it is able to predict other local phenomena with great accuracy. However, the only real tests of general relativity are those that

Although Einstein tried his best to present a non-mechanical and non-kinematical ether to the world, not everyone was buying into it. As noted previously, Dayton Miller's experiments had come into full bloom a few years after Einstein's 1920 Leyden lecture, and thus the possibility of a mechanical ether simply would not go away, which is quite remarkable, since Miller was a heliocentrist who interpreted his interferometer experiments from the perspective that the Earth was moving at 30 km/sec. Yet even from that difficult perspective there were strong indications that a material ether existed. In 1923 Ernst Gehrcke reexamined the Michelson-Morley, Michelson-Miller and Georges Sagnac experiments, not to mention Michelson-Gale, and demonstrated how Relativity theory fell far short of explaining them.

These indications were strong enough that Einstein decided to address the issue in a book with Leopold Infeld in 1938 titled *The Evolution of Physics*. Einstein writes:

Is the ether carried with a room as the air was? Since we have no mechanical picture of the ether it is extremely difficult to answer this question. If the room is closed, the air inside is forced to move with it. There is obviously no sense in thinking of ether in this way, since all matter is immersed in it and it penetrates everywhere. No doors are closed to ether. The "moving room," now means only a moving CS [coordinate system] to which the source of light is rigidly connected. It is, however, not beyond us to imagine that the room moving with its light source carries the ether along with it just as the sound source and air is carried along in the closed room. But we can equally well imagine the opposite: that the room travels through the ether as a ship through a perfectly smooth sea, not carrying any part of the medium along but moving through it. In our first picture, the room moving with its light source carries the ether. An analogy with a sound wave is possible and quite similar conclusions can be drawn. In the second, the room moving with its light source does not carry the ether. No analogy with a sound wave is possible and the conclusions drawn in the case of a sound wave do not hold for a light wave. These are the two limiting possibilities. We could imagine the still more complicated possibility that the ether is only partially carried by the room moving with its light source. But there is no reason to discuss the more complicated assumptions before

have been carried out in the solar system, under nearly stationary conditions, and for X values smaller than 10^{-6} " (J. B. Barbour and B. Bertotti, "Gravity and Inertia in a Machian Framework," *Il Nuovo Cimento*, 32B(1), March 11, 1977, pp. 26-27). As we will see in Appendices 5, 6, 7, and 8, even Einstein's "solar system" tests never proved the theory of General Relativity.

finding out which of the two simpler limiting cases experiment favors.⁹⁰⁴

Einstein then explains why he cannot accept either of these possibilities:

Every attempt to explain the electromagnetic phenomena in moving CS [coordinate systems] with the help of the motion of the ether, motion through the ether, or both these motions, proved unsuccessful....Thus arose one of the most dramatic situations in the history of science. All assumptions concerning ether led nowhere! The experimental verdict was always negative. Looking back over the development of physics we see that the ether, soon after its birth, became the “*enfant terrible*” of the family of physical substances. First, the construction of a simple mechanical picture of the ether proved to be impossible and was discarded. This caused, to a great extent, the breakdown of the mechanical point of view. Second, we had to give up hope that through the presence of the ether-sea one CS [coordinate system] would be distinguished and lead to the recognition of absolute, and not only relative, motion. This would have been the only way, besides carrying the waves, in which ether could mark and justify its existence. All our attempts to make ether real failed. It revealed neither its mechanical construction nor absolute motion. Nothing remained of all the properties of the ether except that for which it was invented, i.e., its ability to transmit electromagnetic waves. Our attempts to discover the properties of the ether led to difficulties and contradictions. After such bad experiences, this is the moment to forget the ether completely and to try never to mention its name. We shall say: our space has the physical property of transmitting waves, and so omit the use of a word we have decided to avoid. The omission of a word from our vocabulary is, of course, no remedy. Our troubles are indeed much too profound to be solved in this way!⁹⁰⁵

Of course, to today’s Relativist, all this sounds so inviting. Here we have a theory that apparently solves the problem of having to find the elusive ether; dispenses with the metaphysics of absolutes; makes a plausible connection between the distant stars and Earth; and, most of all, saves mankind from having to admit the possibility of a motionless Earth. As we have noted previously, however, the theory of Relativity was created under the misinterpretations of stellar aberration, interferometer, and other similar experiments. Since it was assumed in

⁹⁰⁴ Albert Einstein and Leopold Infeld, *The Evolution of Physics*, New York: Simon & Schuster, Inc, 1938, 1966, pp. 167-168.

⁹⁰⁵ Albert Einstein and Leopold Infeld, *The Evolution of Physics*, New York: Simon & Schuster, Inc, 1938, 1966, pp. 175-176.

each case that the Earth was moving at 30 km/sec, invariably each experiment was interpreted as giving a null result for the existence of a mechanical ether. If Einstein and modern science had stopped for one brief moment to analyze those experiments from the perspective of a motionless Earth, they would have had positive proof of the ether's existence. The so-called "difficulties and contradictions" would have disappeared, for each experiment invariably showed a small positive result, a result consistent with a universe rotating in a sea of ether around the Earth as its immovable center. Having failed to grasp this truth, Einstein was forced into the fantastic contortions of time and space that we witness above, which, in the end, leave no room for the very thing that began his trek – electromagnetic activity. In fact, the effects of electromagnetic activity in the Sagnac and similar experiments demonstrate that absolute motion exists, and not even the mighty equations of General Relativity could dismiss that incontrovertible fact.

The Inherent Problems of Newton and Einstein's Physics

In the end, the Newtonian and Einsteinian systems are mere mathematical representations of physical forces for which neither system provides real physical answers. Newton developed a physics that interpreted, in mathematical terms, the force of interaction between two bodies, but which was totally independent of the reference frame in which those bodies were contained. The formulas $F = ma$ and $F = Gm_1m_2/r^2$ work only in unaccelerated reference frames. When Newton's formulas are applied to accelerating frames of reference, they do not work unless compensations are added. In an accelerated frame, the two bodies begin to accelerate without a force being applied to them. Hence, Newton's math must be adjusted to compensate for acceleration, and this is accomplished by adding in fictitious components, otherwise known as centrifugal and Coriolis forces. But centrifugal and Coriolis forces, even though measurable, are not products of matter or energy in the Newtonian system. Newton could not explain from whence they originated. Consequently, they are mere inventions of the human mind so as to allow Newton's math equations to balance. Evidently, something is missing. As C. Møller writes:

For example, if we consider a purely mechanical system consisting of a number of material particles acted upon by given forces...Newton's fundamental equations of mechanics may be applied with good approximation....On the other hand, if we wish to describe the system in an accelerated system of reference, we must introduce, as is well known, so-called fictitious forces (centrifugal forces, Coriolis forces, etc.) which have no connexion whatever with the physical properties of the mechanical system itself....It was just for this reason that Newton introduced the concept of absolute space which should represent the system of reference where the laws of nature assume the simplest and most natural form. However...the notion of absolute space lost its physical meaning as soon as the special principle of relativity was generally accepted, for as a consequence of this principle it became impossible by any experiment to decide which system of inertia had to be regarded as the absolute system.⁹⁰⁶

Since Newton was a Copernican and thus did not have a fixed Earth from which to formulate his laws of motion, he ran into several difficulties, if not contradictions, in his formulas. As Dennis Sciama explains it:

Newton's second law can be expressed in the familiar form: force is mass times acceleration. When we look carefully at this

⁹⁰⁶ C. Møller, *The Theory of Relativity*, Oxford, Clarendon Press, 1958, pp. 218-219.

law we find a curious difficulty. For, while the force acting on a body is objectively determined by whatever is exerting the force, the value of the acceleration depends on how it is measured, that is, on which body is taken as providing a standard of rest....A similar example of this difficulty is provided by the motion of artificial satellites. The ones which have been launched so far have circled the earth in an hour or two. But the farther out a satellite is, the longer it takes to complete its orbit. At a certain height it will take just twenty-four hours. If a satellite at this height were to move parallel to the equator and in the same direction as the earth rotates, it would always be above the same point of the earth's surface. Someone looking up would see a body at rest above his head, hovering with no visible means of support! These examples show that Newton's second law applies only if the accelerations of bodies are measured in a special way. Since Newton believed his law to be fundamental, he supposed that accelerations measured in such a way that his law applies are of particular significance, and he called them *absolute*. Newton's second law should now be amended to read: force is mass times absolute acceleration. Those bodies on which no forces act will then have no absolute acceleration. Such bodies are said to constitute an *inertial frame of reference* or simply an inertial frame, because accelerations measured relative to them will be absolute accelerations. Consequently for Newton's second law to be satisfied accelerations must be measured relative to an inertial frame of reference.

Inertial frames naturally play a fundamental role in Newton's theory. Nevertheless, he often found it convenient to use a *non-inertial* frame of reference – that is, to measure accelerations relative to some body whose absolute acceleration is not zero...This procedure leads, of course, to anomalies, in particular that a force may produce no acceleration at all. Nevertheless, Newton was able to adapt his law of motion to fit this situation by postulating the existence of some *additional* forces, which do not have a physical origin in material objects. These additional forces, commonly called inertial forces, are needed to compensate for measuring accelerations relative to a non-inertial frame of reference.⁹⁰⁷

So we see that Newton needed to measure motion by means of a fixed frame, but having none because Copernicus removed the possibility of a fixed Earth from his mind, he created his own fixed frame, which he called “absolute space.” For Newton, the Earth was moving, but absolute space was immobile (a picture which is the very opposite of the what Scripture reveals to us). Thus Newton determined that all motion would be measured against this unseen spatial fortress. In

⁹⁰⁷ Dennis Sciama, *The Unity of the Universe*, pp. 85-89.

order to provide evidence that absolute space existed, Newton introduced his water bucket experiment noted above. He held that, the degree to which the water curved upward would reveal the amount of absolute rotation the water possessed as measured against the immobile space surrounding it. Of course, as others pointed out, this didn't prove the existence of absolute space; rather, it only proved that the water was curving upward against *something*, but its exact identity remained a mystery.

Einstein thought of another way to solve these problems. To answer Newton's problem of having to add centrifugal and Coriolis forces, in the theory of General Relativity Einstein invented "curved space" so as to give matter itself the ability to obey Newton's laws without an external force being applied to the matter. The "force," as it were, came from the curved space which, when a body followed its curved path, made it appear as if it was accelerating. Einstein didn't have an explanation as to why the body followed the curved path (especially with no force pushing it), or how gravity could curve the vacuum of space, or even why an object would follow the so-called "geodesic" path. Moreover, since acceleration and gravity are locally equivalent in General Relativity, then the gravity cause by "curved space" becomes, in essence, another fictitious force similar to Newton's that allows the math equations to balance. The major problem for Einstein, of course, is that the mathematics cannot reveal whether the phenomenon is a fictitious force caused by curvature or a genuine force caused by something else. In fact, Einstein produced his General Relativity field tensors by finding a math equation that he could work backward into Newton's force equations.⁹⁰⁸ In the end, without physical proof of its existence, Einstein's curved space is just as fictitious as Newton's additional inertial forces (e.g., centrifugal and Coriolis forces).

⁹⁰⁸ The 8π component in Einstein's field equation, $G = 8\pi T$ (in which G is the Einstein tensor and T is the stress or energy-momentum tensor), was added by determining what factor was necessary in order to make Einstein's equation equal to Newton's equation. This is why General Relativists, such as Misner, Thorne and Wheeler, can say: "The field equation [$G = 8\pi T$] even contains within itself the equations of motion ("Force = mass x acceleration") for the matter whose stress-energy generates the curvature." Consequently, they have no qualms in saying that $G = 8\pi T$ "...is elegant and rich. No equation of physics can be written more simply, and none contains such a treasure of applications and consequences. The field equation shows how the stress-energy of matter generates an average curvature (G) in its neighborhood... The field equation [$G = 8\pi T$] governs the motion of the planets in the solar system; it governs the deflection of light by the sun; it governs the collapse of a star to form a blackhole; it governs the evolution of spacetime singularities at the end point of collapse; it governs the expansion and recontraction of the universe. And more; much more" (*Gravitation*, pp. 42-43). The expanded Einstein field equation is $R_{ab} - \frac{1}{2}Rg_{ab} = -8\pi T$, where g is the metric tensor, R_a is the Ricci tensor, R is the scalar curvature and T is the energy-momentum tensor. Einstein's original equation included the infamous cosmological constant Λ , and was written as $R_{ab} - \frac{1}{2}Rg_{ab} + \Lambda g_{ab} = -8\pi T$.

Are There Universal Connections in Space?

As Mach and Einstein struggled with the connection between the stars and the water bucket, this dilemma brings us back to the question of how the universe communicates with itself. If space is not a vacuum and is filled with something, it is probably no surprise that several experiments appear to indicate that atomic particles and photons are mysteriously connected, appearing to communicate with each other even when separated by great distances. What one photon does will be replicated by a twin photon across space, even though there is nothing immediately detectable connecting the two photons. It is as if some mysterious force and communication were making each photon perform the same movement.

These strange happenings were just beginning to be noticed back in the early 1800s when [Thomas Young](#) demonstrated that light passing through two adjacent slits produces interference patterns.⁹⁰⁹ In 1909 Goeffrey Taylor discovered that photons from sources as feeble as a candle produce interference lines. The basic question was: with what are the photons interfering in order to make interference patterns?⁹¹⁰ At one point [Paul Dirac](#) was led to postulate that "...each photon then interferes only with itself."⁹¹¹

In 1923, [Clinton Davisson](#) and Charles Kunsman reported a similar phenomenon with electron diffraction. In the same year Louis de Broglie found that all objects have properties of waves (See Appendix 8: "The de Broglie Wavelength"). The lighter the object, the more pronounced the wave effect. An object as small as the electron would thus act very much like a wave. In 1927 Davisson repeated the electron diffraction experiment with Lester Germer. They shot electrons through a piece of nickel crystal. Thinking that the electrons were like little bullets, the two scientists expected to see the electrons react accordingly. Instead, the electrons produced an interference pattern and thus reacted as if they were in wave motion, not particle or ballistic motion.⁹¹²

⁹⁰⁹ Thomas Young, "Experiments and Calculations Relative to Physical Optics," Bakerian Lecture, 1803, *Philosophical Transactions of the Royal Society of London* 94, 1-16.

⁹¹⁰ Geoffrey I. Taylor, "Interference with Feeble Light," (*Proceedings of the Cambridge Philosophical Society*, 15, 114-115, 1909.

⁹¹¹ Paul Dirac, *The Principles of Quantum Mechanics*, Oxford University Press, 4th ed., p. 9.

⁹¹² Nickel has an atomic plane spacing of 0.0909 nanometers. If a beam with a wavelength of 1.17 nanometers is shot at it, the reflection will be at 40 degrees. This depends on the formula $n\lambda = 2d \sin(\theta/2)$ where θ is the angle between the atomic planes; d is the incident beam; and n is a positive integer. George Thompson found the same results, sharing the Nobel Prize with Davisson in 1937.

As time went on, variations of the Davisson-Germer experiment were performed, evolving into the famous “[double-slit](#)“ experiments.⁹¹³ Eventually, a point was reached in which only one electron, about every ten seconds, was discharged towards the two slits. An amazing thing occurred: [interference patterns](#) were still being produced on the photographic plates. Apparently, the electron was “interfering” with something. In fact, the singly discharged electrons seemed to go through the slits alternately so that, as their markings were gradually observed building up on the collecting plate, they produced the same interference pattern as when thousands of electrons were shot all at once at the two slits.⁹¹⁴

Prior to this, a huge theoretical war broke out between the followers of Albert Einstein and the followers of [Neils Bohr](#).⁹¹⁵ The former said the electrons were merely following already-programmed instructions built into them (*viz.*, “hidden variables”), whereas the latter claimed that the electrons randomly chose where they would hit; but that there was some mysterious connection between them so that each electron knew what the other was doing and would act accordingly.

In 1932, [John von Neumann](#) gave a purported mathematical proof that the two theories could not be reconciled, but in 1952 David Bohm suggested that they could be reconciled, at least theoretically. In the double-slit experiment he held that a quantum wave was guiding each particle as it went through the slit. As the particle passes through the slit, so does its wave, and it is the wave that is causing the interference line on the screen. When both slits are open, a particle will pass through one slit or the other, but its wave travels through both slits, again causing the interference lines on the screen. In 1964 [John Bell](#) had shown that the Einstein group was continuing to lose the battle. Using the fact that electrons have various spin orientations⁹¹⁶ (e.g., clockwise

⁹¹³ In 1956 G. Möllenstedt and H. Düker split an electron beam and obtained an interference pattern (*Zeitschrift für Physik* 145, 377-397); in 1961 Claus Jönsson performed the first “double-slit” experiment with electrons, demonstrating interference patterns with up to five slits.

⁹¹⁴ Theoretically, this phenomenon was known to exist by the results of Davisson’s experiments, but the theory could not be tested, at least completely, until the 1960s, and then not conclusively until the 1970s and 1980s. Experimental evidence was produced by P. G. Merli et al., “On the Statistical Aspect of Electron Interference Phenomena,” *American Journal of Physics* 44, 306-307 (1976); Akira Tonomura et al., “Demonstration of Single-Electron Build-up of an Interference Pattern,” *American Journal of Physics* 57, 117-120, (1989).

⁹¹⁵ Einstein’s supporters were Boris Podolsky and Nathan Rosen, who together wrote a paper in 1935 titled “Can Quantum-Mechanical Description of Physical Reality be Considered Complete?” versus the Copenhagen group headed by Bohr (Erwin Schrödinger, Max Born, Werner Heisenberg, et al.).

or counter-clockwise) Bell showed that if two electrons were placed back-to-back and sent to their respective detectors an equal distance away, the electrons will invariably produce opposite spins. Moreover, it doesn't matter how far away the detectors are placed from each other, the results are always the same.⁹¹⁷ This seems to indicate that one electron somehow knows what the other one is doing even when separated by a substantial distance.

In order for the Einstein group to explain this phenomenon, they would have to invoke a long-range physical force that connected the electrons, but this, of course, would immediately obliterate the theory of Relativity. Yet if Einstein employed short-range or "local" solutions (which is the essence of Relativity theory), he still could not produce the accurate answers provided by Quantum Mechanics, and this resulted in an "inequality" between Relativity and Quantum Mechanics, which is why the critique is called "Bell's Inequality" (but sometimes cited as "Bell's Theorem"). Following the work of John Bell, a whole host of physicists performed a series of experiments that confirmed Bell's critique of Einstein.⁹¹⁸

Obviously, some profound phenomenon was occurring that neither Einstein nor Quantum Mechanics had the ability to answer. Einstein was limited by his wish to avoid a physical medium in space, and Quantum Mechanics was limited by the Heisenberg Uncertainty Principle. Since Einstein gave a fallacious interpretation to the

⁹¹⁶ The fact that electrons spin and have a magnetic field was discovered in 1925 by S. Goudsmit and G. E. Uhlenbeck. Later it was also discovered that each atomic particle (proton, neutron, etc.) spins and possesses a magnetic field, but since neutrons have no electrical charge, the magnetic field cannot be due to the spin of the particle.

⁹¹⁷ Further, if the electrons are tested for spin in two perpendicular directions, one particle goes left or right just as when the other one spins up or down. If they are tested for spin in the same direction, the proportion of times when the spins don't correlate increases as the square of the angle between the two directions, which is to be expected.

⁹¹⁸ Beginning in 1968, several physicists confirmed "Bell's Inequality" using photons and protons (1968: Abner Shimony; 1972: Stuart Freedman and John Clauser; 1976: Edward Fry and Randall Thompson; 1982: Alain Aspect; 1986: Michael Horne; 1997: Nicolas Gisin; others include Anton Zeilinger, Richard Holt, M. Laméhi-Rachti, W. Mittig). In every case (except one which was later found to have experimental errors) quantum mechanics provided the correct answers and maintained its superiority over Einstein's "hidden variables" theory. For example, in 1972, Stuart Freedman and John Clauser state: "We have measured the linear polarization correlation of the photons emitted in an atomic cascade of calcium. It has been shown by a generalization of Bell's inequality that the existence of local hidden variables imposes restrictions on this correlation in conflict with the predictions of quantum mechanics. Our data, in agreement with quantum mechanics, violate these restrictions to high statistical accuracy, thus providing strong evidence against local hidden-variable theories" (*Physical Review Letters* 28, 938, 1972). See Amir D. Aczel's *Entanglement*, New York, Four Walls Eight Windows, 2001), for a comprehensive and entertaining history of this phenomenon.

Michelson-Morley experiment and fudged Maxwell's equations, he had already obliterated the concept of a material medium pervading all space; and since Quantum Mechanics did not know the origin of the wave that is attached to particles, everyone was at a loss to explain the double-slit experiment. Weird and spooky interpretations inevitably followed (which these scientists often enjoyed because it elevated physics to an popular status). One such fantastic explanation comes from physicist John Gribbin:

The electrons not only know whether or not both holes are open, they know whether or not we are watching them, and they adjust their behavior accordingly. There is no clearer example of the interaction of the observer with the experiment. When we try to look at the spread-out electron wave, it collapses into a definite particle, but when we are not looking it keeps its options open. In terms of Born's probabilities, the electron is being forced by our measurement to choose one course of action out of an array of possibilities. There is a certain probability that it could go through one hole, and an equivalent probability that it may go through the other; probability interference produces the diffraction pattern at our detector. When we detect the electron, though, it can only be in one place, and that changes the probability pattern for its future behavior – for that electron, it is now certain which hole it went through. But unless someone looks, nature herself does not know which hole the electron is going through.⁹¹⁹

This kind of reasoning has led to some of modern science's most preposterous ideas, such as: electrons have a mind of their own and are purposely trying to deceive us; that everything in the subatomic world is a product of chance; that an object only exists when someone looks at it, or that the observer has some telepathic power to make the electron perform on cue. These fantasy-like interpretations are the result of scientists being locked into a paradigm, and that paradigm started when they incorrectly interpreted the Michelson-Morley experiment. Unfortunately, modern academicians are under the false impression that scientific progress is inevitable; that no grand detours from truth and correct thinking have been made or will be made; that what is done is done and to go back and start all over again would not only be a gut-wrenching embarrassment but it would put millions of careers and salaries in dire jeopardy. No one is willing to take that risk.

The experiments elicit one obvious conclusion: both parties must admit to a physical and superluminal connection between particles. Apparently, there is an underlying mechanism of cause and effect in nature that has eluded their discovery, at least up until now. There

⁹¹⁹ John Gribbin, *In Search of Schrödinger's Cat*, New York, Bantam Books, 1984, p. 171.

appears to be a whole world of forms and forces to investigate that is far deeper than the threshold available in Quantum Mechanics and the singularities of General Relativity. Current instruments simply cannot probe into this mysterious and infinitesimally small universe, and it is the main reason they are forced to hypotheses such as the Heisenberg *Uncertainty Principle*. As [Van Flandern](#) notes:

Of course, nothing about nature requires that the individual agents conveying an action be observably large or otherwise suitable for detection by any human-built apparatus. At one time, single air molecules were unknown to science...Likewise, the photon...was once unknown, although humankind was able to perceive bulk light long before forming cogent ideas about its true nature.”⁹²⁰

Since the infinitesimal dimensions of plancktons defy detection, absolute measurements of position and velocity within them will be indeterminable. Once we understand this relationship, the “spookiness” of Quantum Mechanics is minimized. According to *Scientific American*:

Particles...appear to behave in funky quantum ways simply because we don't, or can't, see this underlying order...The equations of quantum mechanics have an uncanny resemblance to those of the kinetic theory of molecules and, more generally, statistical mechanics. In some formulations, Planck's constant, the basic parameter of quantum theory, plays the mathematical role of temperature. It is as though quantum mechanics describes some kind of gas or ensemble of 'molecules' – a chaotic soup of more primitive entities.⁹²¹

As noted earlier, the density of the plancktons in the universe may be absolutely mind-boggling. M. A. Markov writes of infinitesimal particles (“maximons”) possessing a 3.6×10^{93} g/cm³ density. According to him and many other physicists, this is the fundamental limit of mass density.⁹²² As noted previously, to understand how dense this really is,

⁹²⁰ “Gravity,” in *Pushing Gravity*, p. 93.

⁹²¹ George Musser, “Was Einstein Right?” *Scientific American*, Sept. 2004, p. 89. Musser also quotes Massimo Blasone of the University of Salerno, Italy, stating: “You'd have quantum mechanics as a low-energy limit of some fundamental theory” (*ibid.*, p. 90).

⁹²² Markov put forward his hypothesis in 1965, stating that the finite limit for the mass of elementary particles is the Planck mass, where $m < m_{\text{planck}} = \sqrt{hc/G}$. It was understood as a new universal constant for fundamental mass (M. A. Markov, Supplement of the Progress of Theoretical Physics, 1965, p. 85, as cited in “Spontaneous Breaking of Symmetry and Fundamental Mass” by Umida Ibadova, Dept. of Theoretical Physics, Samarkand, Uzbekistan). Many other physicists promote

one could fit the baryonic mass of approximately 10^{39} universes into a single cubic centimeter. In comparison, we've already noted that only a quadrillionth of the atom is occupied by mass, the rest is "empty space." If this empty space were removed, the atom would be a very dense object. It would be so dense that a teaspoon of it would weigh trillions of tons. Plancktons are even denser, and in fact, they would necessarily constitute the rest of the quadrillion parts of "empty space" between the nucleus and its electrons.

As noted earlier, some have hypothesized fantastic notions that plancktons "pop in and out of existence" from other universes. But any hypothesis of this type inevitably transgresses conservation laws. Every so-called "emission" of a virtual particle amounts to the sudden appearance of additional energy in our universe, while every "absorption" into the adjacent universe amounts to a sudden disappearance of energy from our universe. Thus, we would have violations of the conservation of energy on a grand scale.

The reality is that plancktons do not "pop in and out" but are here to stay, and, in fact, they provide the best model for understanding the "action-at-a-distance" phenomenon, since their extreme density will allow instantaneous wave-transmission over long distances. Einstein was forced by his own theoretical postulates to limit the speed of gravity to a velocity equal to or less than light, since his mathematics wouldn't let it travel any faster. As Martin Gardner explains it to the novice:

Imagine a gigantic pair of scissors, the blades as long as from here to the planet Neptune. The scissors begin to close with uniform speed. As this happens, the point where the cutting edges intersect will move toward the points of the scissors with greater and greater velocity. Imagine yourself sitting on the motionless pin that joins the blades. Relative to your inertial frame, the point of intersection of the blades will soon be moving away.... Suppose that the handles of the scissors are on Earth and the point of intersection of the blades is at Neptune. As you wiggle the handles slightly, the intersection point jiggles back and forth. Could you not, then, transmit signals almost instantaneously to Neptune? No, because the impulse that moves the blades has to pass from molecule to molecule, and this transmission must be slower than light. There are no absolutely rigid bodies in general relativity.⁹²³

So here we have the quintessential distinction between non-ether space and ether space. Since Einstein was forced (so he thought) to dispense with ether because of the Michelson-Morley experiment, there

the same conclusions. See G. W. Gibbons, *Very Early Universe*, Cambridge University Press, 1983, pp. 359-361.

⁹²³ *Relativity Explosion*, pp. 65-66.

can be no “rigid body” filling in the space between the planets and stars. It is a vacuum, according to Einstein. Consequently, gravity doesn’t “travel”; rather, it is created in a certain locale because the mass of a star or planet distorts or ‘pulls in’ the space around it. Of course the logical question is: what is inherent in “space” that a star or planet can affect it, if space, being a vacuum, is filled with nothing? How can nothing be molded to form a certain shape? The alternative answer is that space is, indeed, filled with something. Not only is it “something,” but because its dimensions are in infinitesimally small scales, it fulfills the definition of a “rigid body” and therefore allows for instantaneous transmission of any force between ‘Earth and Neptune,’ or any body in the universe. It was precisely Einstein’s misinterpretation of the interferometer experiments, and thus his failure to consider the possibility of a “rigid body,” that led him down the wrong path to Relativity. As Einstein wrote in one of his last essays:

The concept of space was enhanced by the discovery that there exist no completely rigid bodies. All bodies are elastically deformable and alter in volume with change in temperature.⁹²⁴

⁹²⁴ Albert Einstein, “Relativity and the Problem of Space,” cited in Albert Einstein, *Ideas and Opinions*, New York, Crown Publishers, 1954, Wing Books, p. 365.

The Geocentric Connection

What Einstein could not find, the biblical geocentric universe possesses. The “rigid body” is its foundation. The *firmament* of Genesis 1:6-9, by the very definition of the Hebrew word, is “rigid.” Its rigidity is necessary to form and maintain anything as large as our universe, and that is precisely why it was created as early as the Second Day. All of the above discoveries of modern science concerning the infinitesimal world of Planck particles and its attending phenomena can be synthesized into an ingenious and fascinating model of geocentrism. In fact, this model shows that the Planck dimensions of physics not only constitute the fundamental fabric of space, they are the ingredients essential to make a universe function. [Gerardus Bouw](#), probably the premier geocentric scientist today, has engineered such a model. Basically Bouw argues that the “fundamental constants” of physics (e.g., gravity, electric charges, position, time, temperature, entropy) can only be joined together in a limited number of ways in order that no one constant conflicts with the others. Since there is a plurality of fundamental constants, a least common denominator is needed to join them all together. The melding of these constants is accomplished in two ways: on the one hand, at the extreme ends of the physical spectrum, by reducing the mixing crucible to scales much smaller than atomic particles so that all the necessary constants are represented in their irreducible form; and, on the other hand, to test how these constants react in sizes as big as the universe, which, of course, is the ultimate large scale environment. The most crucial constants that need to be joined together are: Planck’s constant, Boltzmann’s constant, the speed of light, and the gravitational constant.⁹²⁵ As Bouw puts it:

As we proceed to smaller and smaller scales nothing interesting seems to be happening until we get to a scale of about 10^{-33} cm. At that size called a *Planck length*, fascinating things happen...we find that the warp and woof of heaven comes into focus. Physics attempts to derive relationships between the different properties of objects. Such relationships typically involve certain constants: values which are generally assumed not to change over time. The speed of light is such a constant. So is the gravitational constant. It turns out that there are relationships among these constants themselves, and those relationships all express themselves to specifics at the Planck length. For example, the Planck length itself, L , relates Planck’s constant (a unit of angular momentum or spin

⁹²⁵ We hasten to add, however, that the gravitational constant has shown some inconsistency over the years. In 1986, for example, the value assigned to G was $6.67259 \pm 0.00085 \times 10^{-11}$, while in 1998 it was given a value of $6.673 \pm 0.010 \times 10^{-11}$, a factor of ten in just twelve years (Pari Spolter, “Problems with the Gravitational Constant,” *Infinite Energy*, 10:39, no. 59, 2005).

energy), h , the speed of light c , and the gravitational constant G to give a length of 1.616×10^{-33} cm.⁹²⁶

Modern science is not certain as to the meaning of these numbers, but the most popular explanation at present is that they signify particles which pop into existence, exist for about 10^{-44} seconds, and then pop out of existence again. These particles, called Planck particles, form the basis for various cosmological theories such as strings, superstrings, 10-dimensional space, and so on.⁹²⁷

So it seems that we are engulfed in a sea of Planck particles. The particles can be viewed as constituting a pervasive medium which acts like an ideal fluid (meaning that there is no friction). The density, P , of that fluid is an astounding 3.6×10^{93} g/cm³...If this doesn't qualify for the name "firmament," then what does?⁹²⁸

⁹²⁶ Gerardus D. Bouw, *Geocentricity*, Association for Biblical Astronomy, Cleveland, OH, pp. 324-325. Bouw continues: "By the same token, the constants give us a fundamental unit of mass M , called the *Planck Mass*, which is 2.177×10^{-5} gm. The corresponding basic unit of time, the *Planck time*, t , is 5.391×10^{-44} sec. [NB: The *Planck length* is the distance light travels (10^{-33} cm) in one Planck time interval (10^{-44} cm)]. Lastly, the fundamental unit of temperature T can be derived by introducing Boltzman's constant, k , and it gives a temperature for the firmament of 1.417×10^{32} °K; a most fervent heat not observed anywhere in the universe."

⁹²⁷ Bouw, *Geocentricity*, p. 325. In Superstring theory the "strings" have dimensions as those in the Planck world. The "strings" are said to have a length of 10^{-33} cm and a mass of 10^{-6} g. Rather than calling them "Planck particles," String theorists have designated them as "strings" in order to provide a mental picture of their function. For example, a closed string produces gravity, hence the popular theory known as "Quantum Loop Gravity." Mathematically, String theory has succeeded in uniting all known particles, including the Higgs boson and fermions, within one spatial superstructure, yet this superstructure must possess 10 or more dimensions in order to do so. An even more accommodating concept is Massive Superstring theory, which is the closest modern science seems to have come in understanding the universe's underlying superstructure. In this theory, the string takes on the complete Planck dimensions of time (10^{-44} sec), length (10^{-33} cm), temperature (10^{32} K) and mass (10^{-5} gm).

⁹²⁸ *Geocentricity*, p. 326. Bouw, of course, is referring to the "firmament" mentioned in Genesis 1:6-9, 14-20 as filling the entire space between the Earth's surface and the edge of the universe, and into which the stars and other heavenly bodies are placed. Many Biblical translators have chosen the word "firmament" in order to signify a firm substance, from the Hebrew word רַקִּיעַ (*raqia*), from the verbal root רָקַע meaning "stamp, spread out, stretch," which is used both to refer to a firm substance that is spread out (as in beaten metal) and the constitution of the heavens (Gn 1:14, 15, 17, 20; Ps 19:2; 150:1; Ez 1:22-26; 10:1; Dn 12:3). In Ex 39:3; Nm 17:3; Jr 10:9 *raqia* appears as "hammered"; while in Ez 6:11; 25:6 it is "stamped"; as compared to "beaten," "crushed" in 2Sm 22:43. In Job 37:18, תַּרְקִיעַ (*taraqia*) is in verbal form ("can you beat out?"), while the same verse treats the firmament as a לִשְׁחַקִּיעִים (*lishechaqeyim*)

A substance of such a high density as the firmament has some interesting properties. One would think, for example, that it would be impossible to move in such a medium, just as one could not move if encased in iron. Normally this is true, but the deBroglie wavelengths of nuclear particles are so long compared to that of the Planck particles that [the] firmament is transparent to them. This is similar to why light can travel through a “dense” medium such as glass instead of being stopped cold on impact. Bouw concludes:

The advantage of the firmamental model is that it can easily account for a number of experimental observations which are harder to explain heliocentrically. These include the Sagnac effect, Faraday disk-generator paradox, Earth’s night-time electric field, and ball lightning. And so both heliocentrically-based quantum mechanics and geocentrically-based firmamental mechanics explain the same phenomena at the Planck scale, albeit with different philosophical assumptions: one assumes that space is filled, the other that space is empty.⁹²⁹

As Markov has suggested these infinitesimal particles would also act as a frictionless fluid. Hence, objects from the size of electrons to those of giant superclusters of stars can move through the sea of plancktons with no resistance, and they will move as all matter does – by wave motion. As such, the wave created as matter moves through the ether is the essence of the de Broglie wave. As light can move through a solid block of transparent material, analogously, solid objects can move through the plancktons that permeate the universe. Contrary to popular opinion, tremendous pressure does not necessarily inhibit movement or cause friction, but will actually help an object to move, since the pressure helps eliminate molecular action against the moving body and allows

from the Hebrew root שחק meaning “crushed” added to the Hebrew for “dust” כעפר (Ps 18:43; 36:5), or “clouds” (Dt 33:26) or “sky” (2Sm 22:12). Thus, the “firmament” is both solid and atmospheric/celestial, and any application must incorporate both qualities. This is what Bouw has done. (Conversely, a solid-shell model of the firmament, which is popular among more traditional Protestant biblical enthusiasts, ignores the atmospheric/celestial dimension, and consequently, does not do proper justice to the Scriptural language). To understand the tremendous density of the Planck “firmament,” Bouw adds: “Let us try to envision such a cube made up of Planck particles. The numbers are incomprehensible. For example, the mass of the entire universe is estimated to be about 2×10^{54} g. Packing everything in the universe into the cube would only give us a density of 2×10^{54} g/cm³, far short of the Planck medium’s 3.6×10^{93} g/cm³. That means that one would have to pack 2×10^{39} universes into the cube to arrive at the appropriate density!” (*ibid.*). In this way, it can be said that the Planck particles are so small that it is as if to us they do not exist, and thus movement through them is as natural as walking through air.

⁹²⁹ Gerardus Bouw, *Bulletin of the Tychonian Society*, No. 46, 1988, p. 33.

energy losses only through turbulence and wave action, provided the pressure is equally distributed. We see this in everyday life, for example, when a submarine experiences less drag and can move more freely the deeper it is submerged into the ocean. In the laboratory, it has been shown that super-cooled helium allows motion of objects through it without any detectable friction. This substance acts so peculiarly at 0.25 degrees above absolute zero that it is understood as a “new phase of matter, a ‘supersolid’ form of helium-4 with the extraordinary frictionless-flow properties of a superfluid.”⁹³⁰ As Robert Laughlin notes:

The similarities between the vacuum of space and low-temperature phases of matter are legendary in physics. Not only are phases static, uniform quantum states, but their most subtle internal motions are physically indistinguishable from elementary particles very generally. This is one of the most astonishing facts in science, and something students always find upsetting and difficult to believe. But they eventually become convinced after looking at enough experiments, for the evidence is plentiful and consistent. In fact, the more one studies the mathematical descriptions of cold phases, the more accustomed one gets to using the parallel terminologies of matter and space interchangeably. Thus instead of a phase of matter we speak of a vacuum. Instead of particles we speak of excitations. Instead of collective motions we speak of quasiparticles. The prefix “quasi” turns out to be a vestige of the historical battles over the physical meaning of these objects and conveys no meaning. In private conversations one drops the pretense and refers to the objects as particles.⁹³¹

⁹³⁰ Barbara Kennedy, “Strong New Evidence of a New, Supersolid Phase of Matter,” *Science Journal*, Penn State University, Summer 2005, p. 8. Kennedy continues: “Solid helium-4 appears to behave like a superfluid when it is so cold that the laws of quantum mechanics govern its behavior.... ‘We used to think that a solid could not flow, but now we have discovered that when you cool solid helium to a sufficiently low temperature it can not only flow, but it actually flows without friction....The implication of our research is that we now have to rethink what we mean by a solid’” (*ibid.*, p. 9). Additionally, at 2.2 Kelvin the helium will have no viscous drag with its rotating container; at certain speeds it will spin twice as fast as its container; and it will mysteriously penetrate through its container. Mercury has been found to have zero resistance to electrical current at 4.1 Kelvin. Sodium atoms at 435×10^{-9} Kelvin stopped the travel of light for a few milliseconds. The discovery of these reactions is based in part on the Planck, Einstein and Bose theory of heat capacity. It theorizes that near 0° Kelvin, atoms may group together under the same wavefunction to act as a single ‘superatom’ and is known as a Bose-Einstein condensate. See *Einstein’s Other Theory: The Planck-Bose-Einstein Theory of Heat Capacity*, Donald W. Rogers, Princeton University Press, 2005, pp. 165-175.

⁹³¹ Robert B. Laughlin, *A Different Universe*, p. 105.

One can imagine what the extent of frictionless qualities would be for a super-fluid at 10^{93} g/cm³. As Bouw views it:

The firmament is like a huge solid block, somewhat analogous to a crystal. At the same time, its granularity is so superfine that it also behaves like a superfluid...All solids are fluid to some extent...Any grouping of lattice frames (such as would constitute a photon, neutrino, proton, atom, molecule, star, galaxy or universe) is not attached to any fixed (determined) position in the firmament's matrix and so can – indeed, must – move, rotate, or both move and rotate relative to the firmament. As such, the entire lattice, which is the stellar universe, can be treated as an entity independent of the firmament.⁹³²

As Bouw describes it in modern terms:

In short, this means that the firmament is an underlying medium. The atoms and galaxies of our universe are merely tiny, insignificant disturbances in the firmament. Because of the Heisenberg Uncertainty Principle matter is totally unaware of the firmament's existence. If it were not for Scripture, we would be equally unaware of it. Only on extremely small scales, distances of the order of a Planck length, does the firmament show through the warp and woof of space....The firmament which God created on the second day is thus an extremely massive structure. Its properties are manifold and in a very literal sense, it determines the very physics of the universe....From the perspective of modern science, the firmament...is a very viable scientific option. It is a super-dense, created medium which mimics a plenum. It does so by both keeping absolute position and time indeterminate within it (Heisenberg Uncertainty Principle), as well as allowing only wave motions and disallowing absolutely straight line motion....It reacts instantly to any changes within it (in about 10^{-78} seconds). Material objects can only become vaguely aware of its existence on extremely large scales (of the order of the size of the universe) and on extremely small scales (of the order of sub-nuclear particles). *None of these phenomena are new, all have been noted before in the scientific literature.*⁹³³

⁹³² Gerardus Bouw, *Bulletin of the Tychoonian Society*, No. 47, 1988, p. 13. Bouw adds that the firmament is larger than the universe, and it is the universe that is expanding, not the firmament. The firmament would thus have to be larger in radius than the universe, equal to the amount of time the universe has and will expand. In biblical proportions this would equal approximately 10,000 light-years or less. The “independence” of the firmament from the universe is the reason for the Heisenberg Uncertainty Principle.

⁹³³ *Geocentricity*, p. 329. Emphasis added.

Noted above is a reference to the reaction time within the firmament. Expanding on this concept, Bouw presents an ingenious system of calculations that demonstrate the speeds at which waves traverse the universe. Each calculation follows the known laws of physics. The first calculation is the speed of sound as a function of tension (T), otherwise known as “transverse waves,” which is how light beams, or even hand-held oscillating ropes, travel through space. The equation for a transverse wave is: $v_t = \sqrt{T/\mu}$ where μ is the mass per unit length. In the Planck dimensions, the mass of the firmament is 2.2×10^{-5} grams over a length of 1.6×10^{-33} centimeters, yielding a value for μ at 1.89×10^{56} gm/cm. Interpreting the tension as the gravitational attraction between plancktons, the gravitational force is: $T = G\mu^2 = 1.27 \times 10^{49}$. Substituting these values in the original formula [$v_t = \sqrt{T/\mu}$] yields $v_t = 3.04 \times 10^{10}$ cm/sec, which is within the margin of error for the speed of light, and thus, as Bouw concludes: “the transverse-wave speed of a disturbance in the firmament is the observed speed of light.”⁹³⁴

A second calculation of speed can be based on temperature. In the Planck dimensions, the firmament has a temperature of 1.42×10^{32} Kelvin. The quantum speed, v_q , is related to Boltzmann’s constant, k , while the particle mass, m , in the equation: $v_q = \sqrt{3kTm^{-1}}$, which yields a value for v_q as 5.17×10^{10} cm/sec.⁹³⁵

The third calculation is the most significant since it measures the speed of the pressure wave (compressional or longitudinal) through the firmament. This calculation depends on the compressibility of the universe in the firmament. The speed of the pressure wave, v_b , is derived by its relation to the density, ρ , in the equation: $v_b = \sqrt{B_m/\rho}$. Then, using a bulk modulus relating pressure to volume by the formula $B_m = (P - P_o) V_o/V_o - V$, where P and V are the compressed pressure and volume and P_o and V_o are the original values. Assuming a difference in compression between space and the firmament, $P_o = 0$ while $P = 10^{49}$ (the pressure between two plancktons). $V_o = 10^{85}$ cm³, the volume of the universe. The final volume is 10^{-39} cm³. The density is the critical density of the universe set at 10^{-29} gm/cm³. Applying these estimate in the formula: $v_b = \sqrt{B_m/\rho}$, then $v_b = 3 \times 10^{39}$ cm/sec as the speed of the compression waves. At this rapid speed the compression wave crosses the universe in 10^{-11} seconds, virtually instantaneously. Depending on adjustments to the above figures, the upper limit for the speed of the compression wave is the Planck time of 10^{-44} seconds as opposed to 10^{-11} seconds.⁹³⁶

⁹³⁴ Gerardus Bouw, *The Biblical Astronomer*, vol. 12, no. 99, 2002, pp. 17-18.

⁹³⁵ In this case Bouw notes: “This is roughly twice the speed of light and may well be equal to the speed of light given that the coefficient of 3 assumes three degrees of freedom for the particle. If there’s only one, then they speed becomes 2.98×10^{10} cm/sec which is the speed of light” (*ibid.*, 18).

⁹³⁶ *Ibid.*, p. 19.

Finally, whatever we will discover in the future regarding the balance between the Planck world, the electropon net, electromagnetic radiation, the Cosmic Microwave Background radiation,⁹³⁷ long wavelength photons,⁹³⁸ or the neutrino sea, the point is made that there are many viable ingredients as to the constituents of ether, as well as understanding why Michelson-Morley and every other interferometer experiment for the next 50 years all measured a resistance to the ether. Since, as these experiments indicate, Earth is motionless at the center of a universe filled with infinitesimally small particles that are revolving around it, we would expect only a slight resistance to register in the interferometers located at the Earth's surface. It is a fact of science that we did, indeed, obtain that slight resistance, and which resistance has heretofore been dismissed by modern science. In fact, the wave/particle duality of light, the mysterious results of the "double-slit" experiment, the de Broglie wave or the Schrödinger wave, may be nothing more than the effect of particles (e.g., photons, electrons, etc.) reacting to the infinitesimal medium through which they travel. A particulate medium many times smaller than atomic particles and photons must be very dense, and thus it can allow movement only through wave motion. Thus, any particle moving through the medium, including photons, will create waves proportional to the speed that the entity is able to travel through the medium. The undulation of the wave itself, however, can travel at superluminal speeds, due to the extreme density of its substance. In this way, the issue of "causality" is undisturbed, since there is direct contact between physical entities that will cause eventualities.

⁹³⁷ "Induction of Gravitation in Moving Bodies," Matthew R. Edwards in *Pushing Gravity*, p. 139; "Action-at-a-Distance and Local Action in Gravitation," Toivo Jaakkola in *Pushing Gravity*, p. 158.

⁹³⁸ "Gravitation as a Compton Effect Redshift," John Kierien in *Pushing Gravity*, pp. 132-133.

“This is the sign to you from the Lord, that the Lord will
do this thing that he has promised:
Behold, I will make the shadow cast by the declining sun
on the dial of Ahaz turn back ten steps.” So the sun
turned back on the dial the ten steps
by which it had declined.

Isaiah 38:7-8

"There is something fascinating about science. One gets such wholesale returns of conjecture out of such a trifling investment of fact."

Mark Twain⁹³⁹

A scientific theory neither explains nor describes the world; it is nothing but an instrument."

Karl Popper⁹⁴⁰

"It is really quite amazing by what margins competent but conservative scientists and engineers can miss the mark, when they start with the preconceived idea that what they are investigating is impossible. When this happens, the most well-informed men become blinded by their prejudices and are unable to see what lies directly ahead of them."

Arthur C. Clarke⁹⁴¹

"There are many hypotheses in science which are wrong. That's perfectly all right; they're the aperture to finding out what's right."

Carl Sagan⁹⁴²

⁹³⁹ *Life on the Mississippi*, 1883, p. 156.

⁹⁴⁰ *Conjectures and Refutations: The Growth of Scientific Knowledge*, p. 102.

⁹⁴¹ Arthur C. Clarke, *Profiles of the Future: An Inquiry into the Limits of the Possible*, New York: Holt, Rinehart and Winston, 1963, 1984, pp. 21-22. Clarke is also the author of *2001: A Space Odyssey*.

⁹⁴² Attributed.

Chapter 8

Preliminary Investigation into the Cause of Gravity

[Gerardus ‘t Hooft](#), a 1999 Nobel Laureate and theoretical physicist at Utrecht university puts things in perspective. Although Quantum Mechanics has been ballyhooed as science’s greatest achievement, Dr. t’ Hooft responds that it “is not the ultimate theory of nature...quantum mechanics is simply how the ultimate theory of nature is revealed to us.” In an interview for *Discover*, science correspondent Kathy Svitil concludes that

The heart of the problem is gravity. General relativity describes the way gravity operates on large scales but does not explain its origin. Quantum mechanics describes the subatomic world where the forces of nature arise, but it turns increasingly vague over extremely small distances. Quantum theory falls apart entirely at the Planck length – an unimaginably minuscule distance some 10^{-20} times the size of a proton – which is precisely where gravity holds sway. In ‘t Hooft’s view, the universe follows orderly rules at the Planck length...⁹⁴³

As Svitil states, gravity has, and remains, the unsolvable problem for any theory of physics. If, as ‘t Hooft is suggesting, the universe consists of a sea of Planck-dimension particles, there may be some means of discovering not only gravity’s *physical* cause but also the “action-at-a-distance” problem that has been around as long as Isaac Newton first broached the subject.

The Theories of Isaac Newton

One might think that for all the scientific knowledge man possesses, he would have discovered by now what causes one of the most simple and common occurrences in the world – gravity. The reality is, however, that modern science is completely baffled about the nature of gravity. Most people are familiar with the story of [Isaac Newton](#) sitting under an apple tree whereupon an apple falls on his head and Newton suddenly jumps to his feet realizing that some kind of force must have made the apple move downward. Regardless whether this story is mere folklore, the question remaining for Newton and the rest of modern

⁹⁴³ *Discover*, May 2003, p. 13; Gerald ‘t Hooft, *Salamfestschrift*, eds., A. Ali, J. Ellis and S Randjbar-Daemi, World Scientific, Singapore, 1993. Gia Dvali, a physicist from New York University, says much the same: “Gravity is the biggest mystery. It’s the oldest force we know, but we still understand so little about it” (*Discover*, October 2005, p. 57).

science concerned what “force” was making the apple move. Was this a force inherent in matter itself that caused it to be attracted by other matter? Or was something pushing the apple toward the Earth? Although he speculated, Newton didn’t know. The only thing he could do is measure, within a respectable margin of error, the rate at which the apple, with its particular mass, fell to the Earth.

Oft quoted from Newton is his letter to Bentley stating that he did not believe gravity was intrinsic to matter itself:

It is inconceivable that inanimate brute matter should, without the mediation of something else which is not material, operate upon and affect the matter without mutual contact; as if it must do if gravitation, in the sense of Epicurus, be essential and inherent in it. And this is the reason why I desired you would not ascribe innate gravity to me. That gravity should be innate, inherent and essential to matter, so that one body may act upon another at a distance through a vacuum, without mediation of anything else, by and through which their action and force may be conveyed from one to another, is to me so great an absurdity that I believe no man who has in philosophical matters a competent faculty of thinking can ever fall into it. Gravity must be caused by an agent acting constantly according to certain laws; but whether the agent be material or immaterial I have left to the consideration of my readers.⁹⁴⁴

The truth is that Newton wavered back and forth on whether gravity had a physical cause, and offered one of the first theories of its mechanical origin. His original theory incorporated the concept of a universal ether, which gave explanations for light, electric, magnetic, and gravitational forces. The ether that caused gravity was said to be tenacious and elastic in nature, condensing on objects as it descended from above (original spelling):

In which descent it may beare downe with it the bodyes it pervades with force proportionall to the superficies of all their parts it acts upon; nature making a circulation by the slow ascent of as much matter out of the bowels of the Earth in an aereall forme which for a time constitutes the Atmosphere, but being continually boyed up by the new Air...riseing underneath, at length...vanishes againe into the ethereall Spaces...and is attenuated into its first principle.⁹⁴⁵

⁹⁴⁴ Third Letter to Bentley, February 25, 1693, Newton’s Correspondence, registered in the Royal Society in 1675, *Correspondence*, vol. 3, p. 253.

⁹⁴⁵ Letter to Halley, June 20, 1686, in reference to Newton’s paper “An Hypothesis Explaining the Properties of Light,” registered in the Royal Society in 1675, *Correspondence*, p. 366; cited in *Annals of Science*, 25, 25-260, (1969), cited by E. J. Aiton in “Newton’s Ether-Stream Hypothesis and the Inverse Square Law of Gravitation” in *Pushing Gravity*, p. 61.

As to the origin of his inverse-square law, Newton held that it was ether (aka “spirit”) that determined this mathematical formula:

...that the descending spirit [ether] acts upon bodies here on the superficies of the Earth with force proportional to the superficies of their parts, which cannot be unless the diminution of its velocity in acting upon the first parts of any body it meets will be recompensed by the increase of its density arising from that retardation....Now if this spirit [ether] descend from above with uniform velocity, its density and consequently its force will be reciprocally proportional to the square of its distance from the center. But if it descend with accelerated motion, its density will every where diminish as much as its velocity increases, and so its force (according to the Hypothesis) will be the same as before, that is, still reciprocally as the square of its distance from the center.⁹⁴⁶

Four years later, Newton replaced the ether-stream idea by another hypothesis that postulated the increase in size of the particles with their distance from the center of the Earth. The larger particles would not fill in the pores of material bodies, which would leave room for the smaller particles to do so, and in turn displace the body downward.⁹⁴⁷ Newton, however, wavered on a mechanical cause for gravity, at times attributing its cause to God’s omnipresence, and later [Fatio de Duillier](#) writes of him:

The plain truth is that he believes God to be omnipresent in the literal sense....He believes they [the Ancients] reckoned God the cause of it, nothing else, that is no body being the cause, since every body is heavy.”⁹⁴⁸

In 1686, in a letter to Halley, Newton wrote of his inverse square law: “...but downwards that proportion does not hold,” which he attributed to a reduction of the ether stream in the interior of the Earth by condensation.⁹⁴⁹ In the second edition of the *Principia* in 1713, Newton stated that the force of gravity “operates not according to the quantity of the surfaces of the particles upon which it acts, but according to the

⁹⁴⁶ *Ibid.*, Letter to Halley, *Correspondence*, p. 447.

⁹⁴⁷ *Ibid.*, *Correspondence*, p. 295.

⁹⁴⁸ “Gravity in the Century of Light” in *Pushing Gravity*, *ibid.*, p. 14. “Fatio on the Cause of Universal Gravitation,” pp. 56, 61.

⁹⁴⁹ “Newton’s Ether-Stream Hypothesis and the Inverse Square Law of Gravitation” in *Pushing Gravity*, ed. Matthew R. Edwards, Montreal: C. Roy Keys Inc, 2002, p. 61.

quantity of the solid matter which they contain.”⁹⁵⁰ In the 1717 second edition of his *Opticks*, however, Newton suggested an alternate mechanical cause for gravitation, supposing that the density of the ether increased with the distance from the Earth, so that the elastic force of the ether impelled bodies towards the less dense parts.⁹⁵¹ E. J. Aiton sums up Newton’s view as

Although, as Newton admitted, the hypothesis was “one of my guesses which I did not rely on,” his argument rested on the premise that, in its implications, the hypothesis reliably reflected his exact scientific views. As interpreted by Newton himself, the ether-stream hypothesis implies the inverse square law in free space, whether the velocity of the ether-stream is constant or accelerated.⁹⁵²

⁹⁵⁰ *Mathematical Principles of Natural Philosophy*, Berkeley, 1962, p. 546, cited by Frans van Lunteren, “Fatio and the Cause for Universal Gravitation,” *Pushing Gravity*, p. 56.

⁹⁵¹ Isaac Newton, *Opticks*, Dover Publications, 1952, Query 21, cited by van Lunteren, p. 62. Oliver Lodge notes in this regard: “First of all, Newton recognized the need of a medium for explaining gravitation. In his “Optical Queries” he shows that if the pressure of this medium is less in the neighbourhood of dense bodies than at great distances from them, dense bodies will be driven toward each other; and that if the diminution of pressure is inversely as the distance from the dense body, the law of force will be the inverse square law of gravitation” (*The Ether of Space*, 1909, p. 111).

⁹⁵² “Newton’s Ether-Stream Hypothesis,” in *Pushing Gravity*, p. 64.

The Theory of De Duillier and Le Sage

In 1690, [Nicolas Fatio de Duillier](#), a Swiss mathematician who, some say, had an intimate relationship with Newton,⁹⁵³ presented an explanation of universal gravitation, of which Newton approved, to the Royal Society. Initially, Fatio sought to reconcile Newton's mathematical computations with Huygens' physical medium for gravity, thus introducing the concept of infinitesimally small particles traveling through or interacting with porous material bodies. Newton favored Fatio's theory, stating:

And these are the necessary conditions of an hypothesis by which gravity is to be explained mechanically. The unique hypothesis by which gravity can be explained is however of this kind, and was first devised by the most ingenious geometer Mr. N. Fatio.⁹⁵⁴

Georges-Louis Le Sage was introduced to Fatio's theory through Gabriel Cramer in 1749, Fatio having died in 1753. Le Sage referred to the mechanical substance undergirding gravity as "ultramundane corpuscles," from his belief that God launched the corpuscles into motion at the beginning of creation from reaches outside the known universe, and thus they were "ultramundane."⁹⁵⁵ James Evans adds:

Le Sage deduces the inverse-square law...a small spherical region of space, traversed by current of ultramundane corpuscles traveling in all directions. The number of corpuscles that cross a unit of area on the surface of this small sphere will be spread out over a correspondingly larger area on the surface of a larger surrounding sphere, in such a fashion that the number crossing through a unit area will fall off as the inverse square of the distance...in Le Sage's system, apparently solid objects must be made mostly of empty space. In his *Mechanical Physics*, Le Sage speculated that the atoms of ordinary matter are like 'cages,' that is, they take up lots of space, but are mostly empty. In this way, ordinary objects block only a tiny fraction of the ultramundane corpuscles that are incident upon them.⁹⁵⁶

⁹⁵³ F. Manuel, *A Portrait of Isaac Newton*, Cambridge, MA, 1968, pp. 191-212.

⁹⁵⁴ *Principia*, Book III, cited in "The Unpublished Scientific Papers of Isaac Newton," A. R. Hall and M. Boas Hall, eds., Cambridge, MA, 1962, p. 315, cited by Frans van Lunteren in "Fatio on the Cause of Universal Gravitation," in *Pushing Gravity*, p. 55.

⁹⁵⁵ Evans, "Gravity in the Century of Light," *Pushing Gravity*, p. 25.

⁹⁵⁶ *Ibid.*, pp. 25, 31.

Le Sage's theory was largely rejected, mainly by the objections of [James Clerk Maxwell](#), although no one else, including Maxwell, offered an alternative model for the cause of gravity. Maxwell had rejected it mainly on thermodynamic grounds, claiming that the transfer of high kinetic energy from the corpuscles to material object would incinerate the latter.⁹⁵⁷ [Pierre-Simon Laplace](#) (d. 1827), although never committing to Le Sage's theory, nevertheless concluded:

...if one absolutely wants a mechanical cause of weight, it appears to me difficult to imagine one which explains it more happily than the hypothesis of M. Sage...⁹⁵⁸

[Henri Poincaré](#) had also rejected Le Sage's theory on the same basis as Maxwell, claiming that it would require the corpuscles to travel at 10^{24} faster than light, which would incinerate the material objects it touched. Le Sage had countered that his corpuscles would only have to move at 10^{13} faster than light.⁹⁵⁹ To account for the objection from Poincaré, modifications to Le Sage's model were introduced by Kelvin and Preston. [Kelvin](#) (William Thomson) had established the kinetic theory of gases in 1873, and developed the idea that Le Sage's corpuscles behaved as gases, suggesting that the excess energy be dissipated by vibration and rotation of the corpuscles.⁹⁶⁰ Maxwell and Poincaré then took a second look at the theory, especially in regard to the effects of gravitational shielding during eclipses, which also interested [Quirino Majorana](#) and [Albert Michelson](#).⁹⁶¹ In 1877 Preston showed that Maxwell's mathematical formula was unbalanced. Maxwell died two years after Preston's paper, and thus his final thoughts are not known. In 1881, however, Kelvin retracted his support of Le Sage's

⁹⁵⁷ Maxwell published his review in the Ninth Edition of the *Encyclopedia Britannica* under the title "Atom," in 1875. Maxwell used the formula $p = Nmu^2$, where p is the pressure of the corpuscles, m the mass of the corpuscle, N the number of corpuscles, and u the velocity of the same.

⁹⁵⁸ Laplace to J. -A. Deluc, October 1781, in Le Sage papers, Geneva, BPU; Ms. Suppl. 513, f. 260, cited by Evans, p. 31.

⁹⁵⁹ James Evans, "Gravity in the Century of Light," in *Pushing Gravity*, p. 24.

⁹⁶⁰ "Le Sage's Theory of Gravity: The Revival by Kelvin," Matthew R. Edwards in *Pushing Gravity*, pp. 68-71.

⁹⁶¹ Majorana found that placing a lead mass between a lead sphere and the Earth reduced the gravitational pull on the sphere, although very slightly, whereas placing the lead mass above the sphere did not alter the pull. Majorana concluded that this contradicted Le Sage's theory of gravity, but it is also inconsistent with Newton's theory, since it does not account for gravitational shielding. Others hold that there is no clear distinction between Majorana's and Le Sage's views, even in principle; still others have found little or no results from gravitational shielding.

theory based on its seeming inability to explain the perfect isotropy of gravity. Still, [Lorentz](#) in 1900 and Brush in 1911 attempted to revive Le Sage's theory by substituting electromagnetic waves for corpuscles. Assuming space is filled with radiation, Lorentz showed that charged particles would attract each other, but only if the incident energy were completely absorbed, which brought back the possibility of incineration. After this, Le Sage's theory had few adherents, especially since General Relativity dispensed altogether with a corpuscular theory of gravity, even though, as we noted earlier, Einstein still maintained the concept of "physical" ether defined by spacetime tensors.⁹⁶²

⁹⁶² Others who continued the Le Sage models appeared in the second half of the twentieth century, including Radzievskii and Kagalnikova (1960); Shneiderov (1961); Buonomano and Engel (1976); Adamut (1976, 1982); Veselov (1981); Jaskkola (1996); and Van Flandern (1999).

The Problems with General Relativity's Gravity Concept

Einstein's postulate that nothing can go faster than the speed of light causes severe problems for current cosmology's concept of gravity, for gravity must then travel at the same speed, or a speed less than that of light. But a gravitational force that is limited to the speed of light will cause enormous problems for the vast distances it must travel in the universe. For example, considering that the distance between the sun and Earth is 143 million kilometers, light from the sun takes 8.5 minutes to reach Earth. We on Earth don't notice this travel time because light is continually being discharged from the sun, but if the sun were to stop shining, we wouldn't notice the absence of light until 8.5 minutes later (at least according to presently accepted theory about light). Now, imagine gravity working the same way. Since, as Newton's laws require, the sun, in the heliocentric model, is continually tugging at the Earth so that the Earth does not go flying off into space, then the force of gravity must be absolutely constant. Current science believes that the force of gravity travels from the sun to the Earth in 8.5 minutes or more. But this slow speed of gravity is not said to be a problem because, as is the case for light from the sun, the gravity sent from the sun to the Earth has been undisturbed for thousands of years. Its slow speed will not cause any problems because it already has an established connection between the sun and the Earth.

Although this may solve one problem, it creates another. By the same theoretical principle, if the sun were suddenly to stop issuing the force of gravity, the Earth would immediately depart from its orbit, the same as when we cut the string from a ball being twirled around in a circle. Once the string is cut, the ball will depart its orbit.⁹⁶³ Conversely, light doesn't need an anchor in order to propagate. But since gravity is a radial force in Newtonian physics, it must operate under different laws. If not, then Newton's laws cannot be applied to the orbits of planets. The question remaining is: what principle of physics would account for the *immediate* reaction of the Earth if the gravitational "string" between them were suddenly cut?⁹⁶⁴ This is similar to the problem that Newton

⁹⁶³ General Relativity tries to explain this dilemma by postulating that gravity isn't really a "force," per se, but only the result of matter (in this case, the matter of the sun and the planets) bending time and space, that is, the Earth follows a path that has been created by the sun pulling space into a circular frame.

⁹⁶⁴ According to physicist Tom Van Flandern, gravity travels at least 2×10^{10} times faster than light. Van Flandern cites several methods of testing this speed, among them: (1) the angular momentum argument of binary pulsars, showing that the position, velocity, and acceleration of each mass is anticipated in much less than the light-time between the masses; (2) a non-null, three-body experiment involving solar eclipses in the Sun-Earth-Moon system, showing that optical and "gravitational" eclipses do not coincide; (3) neutron interferometer experiments, showing a dependence of acceleration on mass, and therefore a violation of the weak equivalence principle (the geometric

had in explaining why the water in a spinning bucket would curve upward.

As we noted earlier, General Relativity has its own problems in explaining gravity (and, for the record, Quantum Mechanics has no explanation for gravity). Physicist [Thomas Van Flandern](#) has pointed out many problems in General Relativity's hypotheses about gravity, and with good reason. Not only has General Relativity failed to provide adequate answers for stellar aberration, rotation, and action-at-a-distance (that is, without resorting to Mach's "distant rotating masses"), Van Flandern reminds us that

...it is not widely appreciated that this [General Relativity] is a purely mathematical model, lacking a physical mechanism to initiate motion. For example, if a "space-time manifold" (like the rubber sheet) exists near a source of mass, why would a small particle placed at rest in that manifold (on the rubber sheet) begin to move toward the source mass? Indeed, why would curvature of the manifold even have a sense of "down" unless some force such as gravity already existed. Logically, the small particle at rest on a curved manifold would have no reason to end its rest unless a force acted on it.⁹⁶⁵

We might also add, if Relativity assumes a uniform curvature of space around any celestial body, why does Relativity accept that the orbits of the planets around the sun are elliptical instead of circular? According to Relativity, the planets stay in their orbits because they are

interpretation of gravitation); (4) the Walker-Dual experiment, showing in theory that changes in both gravitational and electrostatic fields propagate faster than the speed of light, c , a result reportedly given preliminary confirmation in a laboratory experiment. Being a heliocentrist, Van Flandern also depends on what he understands as: (5) a modern updating of the classical Laplace experiment based on the absence of any change in the angular momentum of the Earth's orbit (a necessary accompaniment of any propagation delay for gravity even in a static field); and (6) planetary radar-ranging data showing that the direction of Earth's gravitational acceleration toward the Sun does not coincide with the direction of arriving solar photons, but these can also be explained in the geocentric system by simply reversing the roles of Earth and Sun. (T. Van Flandern, *Physical Letters A* 250, 1998, 1-11; T. Van Flandern, *Dark Matter, Missing Planets and New Comets*, North Atlantic Books, Berkeley, CA, 1993; T. Van Flandern, "Relativity with Flat Spacetime," *Meta Research Bulletin* 3, 9-13, 1994; T. Van Flandern, "Possible new properties of gravity," Parts I & H, *Meta Research Bulletin* 5, 23-29 & 38-50, 1996; "The Speed of Gravity: What the Experiments Say," *Meta Research Bulletin*, Oct. 18, 2002; Walker, W. D., "Superluminal propagation speed of longitudinally oscillating electrical fields," abstract in *Causality and Locality in Modern Physics and Astronomy: Open Questions and Possible Solutions*, S. Jeffers, ed., York University, North York, Ontario, #72, 1997).

⁹⁶⁵ "Gravity" in *Pushing Gravity*, p. 94. We can also add that, since General Relativity assumes a uniform curvature of space around celestial bodies, it fails to explain why the orbits of the planets around them are elliptical rather than circular.

following the “curved path of spacetime.” Nothing is said about an elliptical path being an inherent feature of spacetime.

Regarding the problem Newtonian mechanics has in explaining either the spinning water bucket or the fate of a planet cut from the sun’s gravity, General Relativity seeks to answer the problem by postulating the presence of “gravitational fields” which act as a type of agent passing between source and target, able to convey an action, and therefore dependent on the principle of causality. But since that is the case, Van Flandern retorts that

...all existing experimental evidence requires the action of fields to be conveyed much faster than lightspeed. This situation is ironic because the reason why the geometric interpretation gained ascendancy over the field interpretation is that the implied faster-than-light action of fields appeared to allow causality violations [e.g., moving backwards in time, according to the principles of Special Relativity]...Yet the field interpretation of General Relativity requires faster than light propagation. So if Special Relativity were a correct model of reality, the field interpretation would violate the causality principle, which is why it fell from popularity.⁹⁶⁶

Quantum astrophysicists see the same dilemma for General Relativity. Brian Greene writes:

At the end of the day, no matter what holistic words one uses or what lack of information one highlights, two widely separated particles, each of which is governed by the randomness of quantum mechanics, somehow stay sufficiently “in touch” so that whatever one does, the other instantly does too. And that seems to suggest that some kind of faster-than-light something is operating between them. Where do we stand? There is no ironclad, universally accepted answer.⁹⁶⁷

In his 1998 paper, Van Flandern posited that the speed of gravity must travel at least 10 magnitudes higher than the speed of light. He writes: “Laboratory, solar system, and astrophysical experiments for the “speed of gravity” yield a lower limit of $2 \times 10^{10} c$.”⁹⁶⁸

Following Van Flandern’s assertion, a team led by Sergei Kopeikin of the National Radio Astronomy Observatory took advantage

⁹⁶⁶ “Gravity,” pp. 94-95.

⁹⁶⁷ Brian Greene, *The Fabric of the Cosmos: Space, Time and the Texture of Reality*, New York: Alfred A. Knopf, 2004, pp. 117-118.

⁹⁶⁸ “The Speed of Gravity – What the Experiments Say,” *Physics Letters A*, 250:1-11, 1998. He writes: “The speed of gravity...has already been proved by six experiments to propagate much faster than light, perhaps billions of times faster.”

of Jupiter's passing between Earth and the quasar J0842 + 1835 to test the speed of gravity. Kopeikin measured the gravity field distortions caused by Jupiter and published his results in December 2002 to a worldwide audience. Kopeikin stated that the speed of gravity was equal to the speed of light within a 20% margin of error.⁹⁶⁹ Van Flandern then analyzed Kopeikin's data and found serious anomalies:

New findings announced today by S. Kopeikin are invalid by both experimental and theoretical standards...In 2001, S. Kopeikin proposed an experiment to test the speed of gravity.⁹⁷⁰

However, his result as described would have been a hybrid of near-instantaneous effects and lightspeed-delayed effects. The physical interpretation in his proposal...was objected to by T. van Flandern and independently by H. Asada.⁹⁷¹ ...the mistake made by Kopeikin is not unlike measuring the speed of a falling apple and claiming that is the speed of gravity. All gravitational phenomena unique to Einstein's relativity (GR)...arise in a static or near-static gravitational potential field...Disturbances of this potential field or medium are called "gravitational waves," According to GR, such waves propagate at the speed of light, as do all other phenomena associated with the potential field that propagate at all. This speed has been confirmed indirectly by binary pulsar observations. There is no current dispute about this, and no expectation of any other result for the propagation speed of gravitational waves. However, the name notwithstanding, "gravitational waves" have nothing to do with gravitational force. They are ultra-weak disturbances of the potential field or space-time medium due to acceleration of bodies. So far, they have proved too weak to detect directly in any laboratory or astrophysical experiment. They are certainly far too weak to have any influence on any macroscopic body in their path.⁹⁷²

⁹⁶⁹ *Astrophysical Journal Letters*, April 10, 2003.

⁹⁷⁰ "Testing the relativistic effect of the propagation of gravity by a very long baseline interferometry," *Astrophysical Journal*, 556:L1-L5.

⁹⁷¹ Van Flandern, 2002: (<http://metaresearch.org/home/viewpoint/Kopeikin.asp>) and H. Asada in *Astrophysical Journal*, 574:L69-L70.

⁹⁷² Van Flandern, "The speed of gravity," *Meta Research Press Release*, January 8, 2003. To support Van Flandern, in the section of their book titled "Detection of Gravitational Waves," Misner, Thorne and Wheeler state: "Man's potential detectors all lie in the solar system, where gravity is so weak and spacetime so nearly flat that a plane gravitational wave coming in remains for all practical purposes a plane gravitational wave" (*Gravitation*, p. 1004). They add: "Just as one identifies as 'water waves' small ripples rolling across the ocean, so one gives the name 'gravitational waves' to small ripples rolling across spacetime....Propagating through the universe,

Remarking further on gravity's speed, Van Flander states:

Why do photons from the Sun travel at the speed of light in directions that are not parallel to the direction of the Earth's gravitational acceleration toward the Sun? Why do total eclipses of the Sun by the Moon reach mid-visible-eclipse about 40 seconds before the Sun and Moon's gravitational forces align? How do binary pulsars anticipate each other's future position, velocity, and acceleration faster than the light time between them would allow? How can black holes have gravity when nothing can get out because escape speed is greater than the speed of light, and how can they continue to update their external gravity fields?⁹⁷³

Van Flandern also proposes that the gravity-carrying medium (gravitons) and the light-carrying medium (which he calls "elysium") are separate and distinct, although occupy the same space.⁹⁷⁴ This would be similar to the two-ether theory of Rothwarf, wherein the electropon medium is contained within a Planck-particle medium. Obviously, each ether operates on a different scale, since plancktons are 10^{-10} smaller than electrons and positrons. The electron-positron medium will both be controlled by what travels in the Planck medium, i.e., gravity, which will be seen in cases of refraction and other such electromagnetic-affecting phenomena.

according to Einstein's theory, must be a complex pattern of small-scale ripples in the spacetime curvature" (*Gravitation*, p. 943), showing that "gravitational waves" are peculiar to Einstein's spacetime, not a measure of the speed of gravity. They are merely disturbances in the gravity already present. Van Flandern also noticed that Kopeikin changed the terms of the Einstein equation in order to have the speed of gravity not exceed c . Kopeikin "...rules out the possibility of $c_g = \text{infinity}$ or $c_g \gg c$ in his results even before the experiment is performed. Kopeikin defined a new time $\tau = (c/c_g)t$ to replace the coordinate time t in the Einstein equation. However, because (c/c_g) is obviously forced to become very small or zero for large or infinite c_g , the role of the time coordinate is diminished or suppressed altogether by his substitution, which effectively eliminates many relativistic effects already verified in other experiments." In short, Van Flandern shows that Kopeikin was not measuring the speed of gravity, but was interpreting the data in reference to what he already believed about the speed of gravity from General Relativity.

⁹⁷³ "The Speed of Gravity – What the Experiments Say," *Physics Letters A*, 250:1-11, 1998. As just one example of his evidence, Van Flandern remarks that data from the US Naval Observatory shows that the "Earth accelerates toward a point 20 arc seconds in front of the visible Sun, where the sun will appear to be in 8.3 minutes."

⁹⁷⁴ Van Flandern also notes that "The reason for the failure of quantum physics to successfully model gravitation at a quantum level using these entities [the hypothetical 2-spin gravitons] should now be readily evident: the two completely different media are needed for elysium (the light-carrying medium) and for the gravitational-force carrying agents" ("Gravity," p. 116).

Where the Le Sage model did not have a satisfactory answer for the perihelion of Mercury (since Mercury's mass makes no contribution to the perihelion), Van Flandern's "elysium" helps explain what might be the physical cause for Mercury's ellipse:

One of Louis de Broglie's chief contributions to physics was demonstrating that ordinary matter has wave properties too. We are therefore obliged to consider that orbiting bodies will be influenced by the density of the Elysium that they travel through because of the influence of Elysium on their electrons. Qualitatively, therefore, the elliptical motion of orbiting bodies is slowed most by elysium near perihelion, where that medium is densest; and is slowed least near aphelion, where Elysium is sparsest. This velocity imbalance (relatively slower at perihelion, relatively faster at aphelion) rotates the ellipse forward, which is what an advance of perihelion means.... This speed-change concept works well for purely wave phenomena, and allows the elysium concept to predict the first three tests of General Relativity because of its effect on the speed of light.⁹⁷⁵

Whereas it can be shown that light traveling from the sun to Earth has a displacement aberration of 20 arc seconds (which in the heliocentric system is caused by the speed of the Earth, but in the geocentric system is caused by the speed of the sun), gravity between the sun and Earth has no such "aberration" effect, and thus it provides no indication of a propagation speed. In other words, gravity propagates with an instantaneous, or even infinite speed, which was precisely what Newton assumed to be the case.

In dealing with the problem of drag forces and heat which would be caused by both the elysium and graviton ethers, Van Flandern proposes that the ethers dissipate heat equal to the level of absorption, summed up in the mathematical formulas of Victor Slabinski.⁹⁷⁶ As Van Flandern explains:

⁹⁷⁵ "Gravity," p. 99. We should also add that Simhony's electron-positron ether lattice affects the electromagnetic material in a similar way. Although Van Flandern does not say it here, we could also add that the reason atomic clocks run at different speeds at ground level as opposed to high altitudes is due to the varying densities of ether medium close to Earth's surface as opposed to further away.

⁹⁷⁶ "Notes on gravitation in the Meta Model," *Meta Research Bulletin* 7, 33-42; and "Force, Heat and Drag in the Graviton Model," Victor J. Slabinski, in *Pushing Gravity*, pp. 123-128. As Van Flandern summarizes: The gravitational constant (Slabinski's equation 16) depends on the products of absorption and scattering coefficients, the latter being huge compared to the former. Meanwhile, the heat flow (Slabinski's equation 19) depends only on the absorption coefficient (the part of the heat absorbed by matter instead of by elysium), and is therefore miniscule in comparison" ("Gravity," p. 105).

So heat is deposited by gravitons, then is leisurely lost as the elysium circulates and freshens in separate activities that are not part of the graviton absorption/scattering process. This brings to mind the heat generated by a refrigerator. Most of it must be siphoned off and dumped to allow the important part of the process to operate. The net result is just what we need to make the Le Sage graviton model work.⁹⁷⁷

Van Flandern then cites the Michelson-Gale and Sagnac experiments:

Direct measurements of the speed of radio signals through near-Earth space in the Global Positioning System (GPS) show no detectible speed variation down to the level of at most 12 m/s [12 meters per second]. From that, we can conclude that elysium does not rotate with the Earth (as first shown by the Michelson-Gale experiment in 1925). The classical Sagnac experiment of 1913 indicates that elysium also does not rotate with a spinning laboratory platform, which is why a Michelson-Morley-type experiment on a rotating platform does detect fringe shifts. Therefore, elysium constituents must be quite small compared to atomic nuclei – something we might already have inferred from their lack of detection by experiments.⁹⁷⁸

We see here that, although Van Flandern may have a viable alternative to the question of gravity, being a heliocentrist, he will interpret the GPS and interferometer experiments with respect to a rotating Earth (i.e., “elysium does not rotate with the Earth”). But since in Van Flandern’s model the elysium does not rotate with the Earth, then it does not move laterally with the Earth’s revolution around the sun, and this creates a problem for Van Flandern. For if the Sagnac experiment, as he admits, shows absolute rotation against the elysium, then the elysium does, indeed, have measurable effects, and thus the combined effect of the heliocentrism’s Earth rotating (465 meters/sec) and revolving (30,000 meters/sec) should show up in interferometer experiments and GPS lag times, but they do not. Van Flandern accounts for this anomaly by postulating: “Therefore, the elysium constituents must be quite small compared to atomic nuclei – something we might already have inferred from their lack of detection by experiments.” In other words, the elysium, although moving against the Earth at great speed (465 m/s + 30 km/s), has little or no effect on our instruments because of its infinitesimally small constitution. But how small must this medium be while at the same time being large enough to both carry light waves and

⁹⁷⁷ “Gravity,” p. 105.

⁹⁷⁸ “Gravity,” p. 116.

outsized the graviton medium? Van Flandern does not say. The problem with having a suitable light-carrying medium is that, since the frequency of light's wave is 3×10^8 meters/sec, the velocity of any medium-dependent wave is the square root of the medium's elasticity divided by its density. Thus, supporting a wave moving at the speed of light would require a medium with a very high tensile strength and rigidity, but a medium so porous yet resilient that it produces "no detectable speed variations" on the planets which move through it, yet snaps back into its former position immediately. At the same time, this medium is invisible and non-reactive to our human senses. Is there such a medium?⁹⁷⁹ We have already offered the biblical firmament as the perfect medium, and we will develop the idea even more in later chapters

In the geocentric model wherein the Earth is immobile and the ether is moving only slightly against it (1-4 km/sec), there is much less need to have the ether at infinitesimally small dimensions, since there is no need to account for high resistance. For example, as we noted earlier, if one of the ethers were an electron-positron plasma, we have a medium that is relatively close in size to atomic nuclei, yet both elastic and dense enough to support the speed of an electromagnetic wave, as well as supporting massive objects like planets and stars, without being appreciably affected. The other significant feature of the electron-positron plasma is that it has been positively identified. Unfortunately, as we noted earlier, it has also been positively misinterpreted as originating from the creation of matter from energy.

Incidentally, although Van Flandern says that the GPS shows no detectible speed variation, he qualifies this remark by saying "down to the level of at most 12 m/s." In Appendix 7 regarding the Global Positioning Satellites, we note that there is a 50-nanosecond discrepancy between the GPS and the ground stations. The "50 nanoseconds" corresponds to the 12-meter/second to which Van Flandern refers. Although Van Flandern does not say it here, the 12 m/s disparity is due mainly to the Sagnac effect. In the end, although Van Flandern says there is "no detectible speed variation," if, after taking into account that radio signals from the GPS must travel about 13,000 miles to the ground stations, there remains a 12 m/s difference in the reaction time between

⁹⁷⁹ Other theories of gravitons include the "fat graviton" developed by Raman Sundrum of the University of Washington. As Sundrum is motivated by having to deal with the problem caused by the impossible energy created in equations that are based on quantum space containing infinitesimal particles that pop in and out of existence (10^{120} times greater than what we observe), Sundrum proposes that gravitons are actually about 1/200th of an inch in size, yet the graviton "barely interacts with the matter and energy roiling through 'empty space, thereby eliminating the 10^{120} error..." In this model, "the fat graviton tends to skip over objects smaller than itself, so gravity should start to weaken over such short distances" (*Discover*, October 2005, pp. 56-57). Steven Weinberg had estimated the energy of the cosmological constant to be 10^{113} GeV (billion electron volts, which amounts to a density of about 10^{89} grams per cubic centimeter (*Reviews of Modern Physics*, January 1989).

Earth and the GPS, we then have a residual time-lag between Earth and GPS that is comparable to the fringe shifts of the classic interferometer experiments.⁹⁸⁰

⁹⁸⁰ The plane of the GPS orbit is the Earth's equator, and the GPS circle the Earth at an altitude of about 20,000 km (13,000 miles) and complete two full orbits per day. In the heliocentric model, this requires a speed twice that of Earth's rotation. Since the Earth's rotation at the equator is 465 meters/sec, the GPS are traveling at least 930 meters/second. Assuming the 12 meter/second lag, there is a 2.6% disparity between the radio signals and the movement of the GPS against Earth. Interestingly enough, forty years of interferometer experiments show a similar disparity (10% - 2.6%) between the speed of ether against the Earth (3000-8000 meters/second) and the speed of the Earth in its supposed revolution around the sun (30,000 meters/second). Since the ground stations for the GPS are not situated on the equator but are at various latitudes, this would increase the percentage of disparity from 2.5% to 5.0% at latitudes where the rotation speed is 50% of the equator's, to 7.5% at latitudes where the rotation speed is 25% of the equator's.

“Dark” Problems for Newtonian Gravity

Another problem for current cosmology is that, according to Newton’s laws, the universe must have enough matter and energy to fill the enormous spaces left by its so-called “expanding universe.” As it stands, even when all the matter in the universe is added up, the Big Bang theory has only 5% of what it needs to make the model work. Based on Newton’s laws, there simply is not enough matter to account for the gravity and the luminosity normally associated with matter. In other words, there is 95% more gravity and light than there should be. As *Discover* magazine put it:

...when astronomers try to use Newton’s equations on larger scales, say, to predict the movements of the stars orbiting the center of a galaxy, they get the wrong answers. In every single galaxy ever studied, the stars and gas move faster than Newton’s laws say they should.⁹⁸¹

To compensate for this, modern science has invented the matter they need. According to the best estimates, the required matter makes up 95% of the universe yet with one major caveat – it cannot be seen or detected. The name given to this mysterious but as yet undiscovered substance is Dark Matter, and its cousin is Dark Energy. Essentially, the Dark Energy/Matter combination has the distinguished job of providing at least fourteen times more energy for the universe than the collective energies of all the stars, galaxies and black holes. Without Dark Matter and Dark Energy, a whole host of problems would occur. For example, galaxies, because they are spinning so fast, should be flying apart at the seams. Similarly, the constellations simply couldn’t hold themselves together. Dark Matter comes to the rescue, for it provides the necessary mass for Newton’s inverse-square law to operate, and thus act, as Eric Lerner quips, as the “invisible glue” that keeps everything from flying apart.⁹⁸² Without it the stars in the night sky would collapse and move

⁹⁸¹ Tim Folger, “Nailing Down Gravity,” *Discover*, October 2003, p. 36.

⁹⁸² Eric J. Lerner, *The Big Bang Never Happened*, New York, Random House, 1991, p. 13. He adds: “Finnish and American astronomers, analyzing recent observations, have shown that the mysterious dark matter isn’t invisible – it *doesn’t exist*....But that’s not all: dark matter had to be quite different from ordinary matter...one of the two key predictions of the Big Bang was the abundance of helium and certain rare isotopes – deuterium (heavy hydrogen) and lithium. These predictions also depend on the density of the universe. If the dark matter was ordinary matter, the nuclear soup of the Big Bang would have been overcooked – too much helium and lithium, not enough deuterium. For theory to match observation, omega for ordinary matter, whether dark or bright, had to be around .02 or .03, hardly more than could be seen. If it wasn’t ordinary matter, what could the dark matter be? Around 1980 worried cosmologists turned to the high-energy particle physicists. Were there any particles that might provide the dark matter but wouldn’t mess up the nuclear cooking? Indeed, there just might be. Particle physicists provided a few possibilities: heavy neutrinos, axions, and WIMPs (Weakly

against one another.⁹⁸³ To accomplish this feat, however, Dark Matter must be very dense as compared to the matter in galaxies, but this creates an additional problem, since it will require the cores of the galaxies to be hundreds or thousands of times denser than they actually have been observed to be. In addition, the Dark Matter model requires that the smallest galaxies should have been the first to form from the Big Bang and, over time, should become denser than other galaxies, but the raw evidence shows just the opposite. The converse of this scenario should be just as viable, however. If 95% of the universe is claimed to be Dark Matter, and if we find in the end that Dark Matter does not exist, we might hypothesize that the size of the universe has been estimated to be 95% bigger than it really is.

Another name given to the invisible Dark Matter is the acronym WIMP, which stands for “weakly interacting massive particles.” So far, even the most sensitive detectors have not registered any WIMPs.⁹⁸⁴ But without these “fudge factors,” as Michael Nieto calls them, other scientists, such as Israeli physicist Mordehai Milgrom, propose that Newton’s laws need to be radically reworked. Gravity cannot be said to be directly proportional to acceleration, he says, but “proportional to the square of the acceleration.” Milgrom, speaking for the scientific community, is saying that Newton’s laws are inadequate, and possibly incorrect. Perhaps due to coincidence his mathematical equations work in certain confined areas (e.g., our solar system), but it is certainly not because Newton discovered the universal essence of gravity and motion. As Folger states, “...Newton’s and Einstein’s laws will be in for some

Interacting Massive Particle – a catch-all term). All these particles could provide the mass needed for an omega of 1, and they were almost impossible to observe. Their only drawback was that, as in the case of cosmic strings, there was no evidence that they exist. But unless omega equaled 1 (thus lots of dark matter), the Big Bang theory wasn’t even self-consistent. For the Big Bang to work, omega *had* to be 1, and dark matter *had* to exist. So, like the White Queen in *Through the Looking Glass* who convinced herself of several impossible things before breakfast, cosmologists decided that 99 percent of the universe was hypothetical, unobservable particles” (*ibid.*, pp. 13, 34-35).

⁹⁸³ See *Discover*, Bob Berman, “Sky Lights Meet the Dark Universe,” Vol. 25, No 10, October 2004, p. 36. A recent issue of *Science* showed that modern cosmologists believe that the universe is 4% luminous matter; 26% Dark Matter; and 70% Dark Energy (Robert Irion, “The Warped Side of Dark Matter,” *Science*, 300:1894, June 22, 2003).

⁹⁸⁴ Writing in *Nature*, Geoff Brumfiel states: “Researchers from the Cryogenic Dark Matter Search II...have been looking for a type of theoretical particle called weakly interactive massive particles, or WIMPs....The new detector is four times more sensitive than any previous experiment....However since it started running in November last year, the detector has not seen a single WIMP” (“Particle no-show pans former find,” *Nature*, May 6, 2004, p. 1)

major tweaking.”⁹⁸⁵ An alternate theory called “Modified Newtonian Dynamics” (MOND) is a little better in explaining the anomalies.

David Spergel, astrophysicist at Princeton University and member of the Wilkinson Microwave Anisotropy Probe launched by NASA June 30, 2001, states in an interview with *Discover*:

The thing I’m most excited about is the precision....We know that ordinary matter accounts for only 4% of the mass of the universe. The rest consists of dark matter. It confirms many of the predictions we’ve been making.

Later in the interview when Folger asks: “Have we answered all the big questions,” Spergel replies:

There are still a bunch of them. What is dark matter? What is dark energy, the unseen thing that seems to be driving the universe to speed up? Those are fundamental questions. Another big one is understanding what caused inflation, the extremely rapid expansion that occurred in the universe’s first moment of existence. WMAP and other experiments are just beginning to probe the physics of the early universe. And right now we have a model in which 4 percent of the universe is atoms and 96 percent is something else unidentified. I think it’s hard to claim that we know it all!⁹⁸⁶

Spergel admits that he has never detected Dark Matter, has never seen it, and doesn’t even know what it is, yet in the face of all that ignorance he is positive it is out there, and he even knows that “dark energy” (which he also can’t detect) is propelling it. He also admits that science is “just beginning to probe the physics of the early universe,” and doesn’t know what caused the so-called “rapid expansion,” but he is just as positive that there was a Big Bang and that the universe is expanding. This is the point much of today’s science has come to – speculative theory is assumed as fact.

Yet there is even more to the story. Without Dark Matter to balance the equations, not only do Newton’s laws need to be reworked, and not only is the Big Bang teetering on the scaffold, but Einstein’s General Relativity theory is nullified, for it gives the same solutions to matter and motion as Newton’s laws, and is the engine for the Big Bang theory. As we noted earlier, Einstein produced his General Relativity

⁹⁸⁵ *Discover*, October 2003, p. 40.

⁹⁸⁶ *Discover*, May 2003. Similarly, Nobel Laureate Stephen Weinberg stated: “I cannot deny a feeling of unreality in writing about the first three minutes [of the Big Bang] as if we really know what we are talking about” (*The First Three Minutes: A Modern View of the Origin of the Universe*, Basic Books, 1977, p. 9).

field tensors by finding a math equation that he could work backward into Newton's force equations.⁹⁸⁷ As one physicist honestly put it:

Dark matter is needed if one assumes Einstein's field equations to be valid. However, there is no single observational hint at particles which could make up this dark matter. As a consequence, there are attempts to describe the same effects by a modification of the gravitational field equations, e.g. of Yukawa form, or by a modification of the dynamics of particles, like the MOND ansatz, recently formulated in a relativistic frame. Due to the lack of direct detection of Dark Matter particles, all those attempts are on the same footing.⁹⁸⁸

In reality, if there is no Dark Matter, then insofar as Newton and Einstein are involved, we have a classic case of the blind leading the blind.

With all this negative evidence against Dark Matter one might predict that sooner or later it will be exposed for the myth that it appears to be. Recently one of the most comprehensive and reliable studies seeking to detect Dark Matter, the Hipparcos astrometry satellite, concluded the following: "The local dynamical density comes out as $\rho_0 = 0.076 \pm 0.015 M_\odot \text{pc}^{-3}$ a value well below all previous determinations leaving no room for any disk shaped component of dark matter."⁹⁸⁹ In other words, the study has given the most accurate confirmation to date that there is no Dark Matter in the disc of the Milky Way. If there is no Dark Matter in the disc, we can logically assume that there is no such matter in the cosmos at large. Consequently, if the Dark Matter that science is depending upon to answer the anomalies in Newtonian and Einsteinian physics is now removed from their repertoire of pat answers,

⁹⁸⁷ The 8π component in Einstein's field equation, $G = 8\pi T$ (in which G is the Einstein tensor and T is the stress or energy-momentum tensor), was added by determining what factor was necessary in order to make Einstein's equation equal to Newton's equation. This is why General Relativists, such as Misner, Thorne and Wheeler, can say: "The field equation [$G = 8\pi T$] even contains within itself the equations of motion ("Force = mass x acceleration") for the matter whose stress-energy generates the curvature."

⁹⁸⁸ C. Lämmerzahl, O. Preuss and H. Dittus, "Is the Physics within the Solar System Really Understood," ZARM, University of Bremen, Germany; Max Planck Institute for Solar System Research, Germany, April 12, 2006, p. 2.

⁹⁸⁹ M. Crézé, E. Chereul, O. Bienaymé and C. Pichon, "The distribution of nearby stars in phase space mapped by Hipparcos," *Astronomy and Astrophysics*, Sept. 3, 1997, p. 1. On the accuracy of Hipparcos, the authors state: "Since the accuracy of Hipparcos magnitudes is far beyond the necessities of this study, the sampling biases can only result from two effects: the parallax errors which, however unprecedentedly small are still of the order of 10% beyond 100 pc, and the stars lost at the time of the early selection due to the inaccuracy of apparent magnitudes available then" (*Ibid.*, p. 5).

they will be forced to find alternatives. Only time will tell what they will be.

Many other such anomalies exist for the Big Bang theorists that we cannot cover in detail here. Suffice it to say that, such problems have created a major crisis in cosmological science. So far, every theory that is developed to explain the observable phenomenon is invariably contradicted by other theories. As Paul J. Steinhardt of Princeton University resigned himself to say: “If we only had one problem to worry about, you might blame it on [modeling], but when you have five problems, it’s not so easy to dismiss them.”⁹⁹⁰ David Hilton, Caltech physicist, adds: “The question we ask ourselves is, ‘Now what?’ It’s still a puzzle,” to which his partner Jonathan Dorfan of Berkeley, amusingly resigns: “In the end there is irrefutable evidence that we are here.”⁹⁹¹ Thank God for that.

Geocentrists do not have such problems because, almost to a man, they understand that God created the galaxies as they presently appear. If smaller galaxies are not denser than larger galaxies, the simple reason is that they were all created simultaneously with the same density. Moreover, the spiral galaxies may act as clocks for the universe, since the more rapidly spinning core measured against the more slowly moving arms will only allow a limited amount of time before the spiral is wound up into a giant ball, and it will be completed in a few thousand years, not the 13.5 billion for which modern science seeks. In any case, it is interesting to see how tenaciously modern scientists hold on to the concept of Dark Matter even though they have no physical proof that it exists. Yet these scientists – after the same man whose theories led them to the concept of Dark Matter, Albert Einstein – are the very people who reject the existence of ether because it is said to be “undetectable.” As we have discovered, the ether was indeed detected but was either ignored or misunderstood, since science was working on another wrong premise – an Earth in motion.

Gravity has always been the sticking point in any physical or even theoretical physics model. It is not easily explained when it works as expected, much less when it doesn’t follow any of the rules. Not only is it true that Newton’s “laws” do not work for galaxies, more disturbing anomalies came to the surface when scientists discovered that space probes such as “*Pioneer 10*, launched in 1972...seems to be defying the laws of gravity. [It] has been slowing down, as if the gravitational pull on it from the sun is growing progressively stronger the farther away it

⁹⁹⁰ “A Cosmic Crisis? Dark Doings in the Universe” *Science News Online*, Oct. 13, 2001, by Ron Cowen.

⁹⁹¹ “Antimatter,” *Discover*, August 2004, p. 71.

gets.”⁹⁹² The same anomalies were noticed of *Pioneer 11*, as well as the *Ulysses* and *Galileo* probes.

Pioneer 10 is not the only spacecraft acting strangely. *Pioneer 11*, launched in 1973, also slowed down as it pulled away from the sun, right until NASA lost contact with it in 1995. And there's some evidence of similar bizarre effects on two other probes: *Ulysses*, which has been orbiting the sun for 13 years, and *Galileo*, which plunged into Jupiter's atmosphere last month.⁹⁹³

Commenting about these peculiar incidents, [Michael Nieto](#), a well-known theoretical physicist at Los Alamos National Laboratory in New Mexico, concludes: “We don’t know anything. Everything about gravity is mysterious.”⁹⁹⁴ Thomas Bowles, working at the same institution, admits: “Right now, we don’t have a theory of how gravity is created.”⁹⁹⁵ Indeed, it is well to remind ourselves of the fact that neither Newton nor Einstein could explain the how and why of gravity. As Koestler vividly points out

With true sleepwalker’s assurance, Newton avoided the booby-traps strewn over the field: magnetism, circular inertia, Galileo’s tides, Kepler’s sweeping-brooms, Descartes’ vortices – and at the same time knowingly walked into what looked like the deadliest trap of all: action-at-a-distance, ubiquitous, pervading the entire universe like the presence of the Holy Ghost. The enormity of this step can be vividly illustrated by the fact that a steel cable of a thickness equaling the diameter of the Earth would not be strong enough to hold the Earth in its orbit.⁹⁹⁶

⁹⁹² “Nailing Down Gravity,” *Discover*, October 2003, p. 36.

⁹⁹³ “Nailing Down Gravity,” *Discover*, October 2003, p. 36. In the comprehensive paper “Is the Physics within the Solar System Really Understood?” Lämmerzahl, Preuss and Dittus (Max Planck Institute, April 12, 2006, pp. 1-23) show that the Pioneer anomalies cannot be explained by: dust, additional masses in the solar system, an accelerated sun, or the drift of clocks on earth. In addition to the Pioneer anomalies, the Lämmerzahl team remark on the “flyby” anomalies (occasion in which satellites, after swinging by Earth, possess a significant unexplained velocity increase of a few mm/s), and demonstrate that atmosphere, ocean tides, solid earth tides, charging of the spacecraft, magnetic moment, earth albedo, solar wind or spin-rotation coupling explain the problem. The team also shows that the Astronomical Unit has increased over time and that comets return a few days before predicted arrival, both without explanation.

⁹⁹⁴ “Nailing Down Gravity,” *Discover*, October 2003, p. 36.

⁹⁹⁵ *Nature Reviews*, “Gravity Leaps into Quantum World,” January 17, 2002, by Tom Clarke, p. 2.

⁹⁹⁶ *The Sleepwalkers*, p. 511.

Indeed, as Koestler implies, modern science should be holding its head in shame for all the grandiose theories of the universe it has produced over the years when the simple fact is it doesn't have the slightest clue how the most fundamental force of the universe works. The intractable nature of gravity is demonstrated, as Koestler notes, in the image of a 8000-mile-wide steel cable not being able to counteract the centrifugal force of the Earth revolving around the sun, while a mere kitchen magnet stuck to the door of a refrigerator can defy gravity. Not surprisingly, we find that

Newton's concept of a "gravitational force" has always lain as an undigested lump in the stomach of science; and Einstein's surgical operation, though easing the symptoms, has brought no real remedy....Newton, in fact, could only get over the "absurdity" of his own concept by invoking either an ubiquitous ether (whose attributes were equally paradoxical) and/or God in person. The whole notion of a "force" which acts instantly at a distance without an intermediary agent, which traverses the vastest distances in zero seconds, and pulls at immense stellar objects with ubiquitous ghost-fingers – the whole idea is so mystical and "unscientific," that "modern" minds like Kepler, Galileo, and Descartes, who were fighting to break loose from Aristotelian animism, would instinctively tend to reject it as a relapse into the past....What made Newton's postulate nevertheless a modern Law of Nature, was his mathematical formulation of the mysterious entity to which it referred. And that formulation Newton deduced from the discoveries of Kepler...⁹⁹⁷

Complaints against Newton's theory are a constant dripping on the disciplines of physics and astronomy. As one author put it:

...classical [Newtonian] mechanics, with its principle of inertia and its proportionality of force and acceleration, makes assertions which not only are never confirmed by everyday experience, but whose direct experimental verification is fundamentally impossible: one cannot indeed introduce a material point all by itself into an infinite void and then cause a force that is constant in direction and magnitude to act on it; it is not even possible to attach any rational meaning to this formulation. And of all the experiments by means of which textbooks of mechanics are wont to prove the fundamental law

⁹⁹⁷ *The Sleepwalkers*, p. 344. In addition to "Einstein's surgical operation" which "brought no real remedy," Koestler reminds us that "...'universal gravity' or 'electromagnetic field' became verbal fetishes which hypnotized it into quiescence, disguising the fact that they are metaphysical concepts dressed in the mathematical language of physics" (*ibid.*, p. 508).

of mechanics, not a single one has ever been carried out in practice.⁹⁹⁸

Dennis W. Sciama writes: “The Newtonian scheme contains arbitrary elements,”⁹⁹⁹ while Halliday and Resnick complain that in Newton’s theories there are “serious questions of logic that can be raised.”¹⁰⁰⁰ Even more to the point is the quote from [Heinrich Hertz](#), the famous discoverer of radio frequencies in the late 1800s:

It is exceedingly difficult to expound to thoughtful hearers the very introduction to mechanics without being occasionally embarrassed, without feeling tempted now and again to apologize, without wishing to get as quickly as possible over the rudiments and on to the examples which speak for themselves. I fancy that Newton himself must have felt embarrassment.¹⁰⁰¹

Similarly, F. A. Kaempffer writes:

Newton’s second law is certainly one of the most obscure of all the understandable relations underlying our description of the physical world in which we find ourselves. Anyone who has ever tried to explain this law to a person who insisted on asking questions will know the difficulty of giving good reasons for the facts embodied in it....Newton was well aware of these difficulties, as were others, but could find no satisfactory answer to them.¹⁰⁰²

Not only are anomalies about gravity being discovered above and below the surface of the Earth, but the same discrepancies are being discovered on its surface. For example, the results of Galileo’s famed Pisa experiment have recently come into question. As we remember the story, Galileo climbed the tower of Pisa and proceeded to drop two objects, one much heavier than the other, at the same time. Galileo

⁹⁹⁸ E. J. Dijksterhuis, *The Mechanization of the World Picture*, London, Oxford University Press, 1969, pp. 30-31. My thanks to Walter van der Kamp for some of these citations.

⁹⁹⁹ Dennis W. Sciama, *The Unity of the Universe*, New York, Doubleday and Company, Anchor Books, 1961, p. 125.

¹⁰⁰⁰ David Halliday and Robert Resnick, *Physics for Students of Science and Engineering*, New York, John Wiley and Sons, 1963, p. 89.

¹⁰⁰¹ David Halliday and Robert Resnick, *Physics for Students of Science and Engineering*, New York, John Wiley and Sons, 1963, p. 88.

¹⁰⁰² David Halliday and Robert Resnick, *Physics for Students of Science and Engineering*, New York, John Wiley and Sons, 1963, p. 89.

observed that both objects appeared to fall at the same rate of speed. This finding was in contrast to the view held by Aristotle, the Greek philosopher and scientist, who believed that the heavier object would fall faster (at least that is the view commonly attributed to Aristotle).¹⁰⁰³ But scientists have found that other factors, such as the dimensions of the object (e.g., whether it is compact or elongated), have a direct effect on the speed with which the object falls to Earth. These variations are not due to the resistance of air. These sensitive experiments are performed in vacuums. For example, experiments performed with the ultra-sensitive Cavendish torsion balance reveal that elongated objects, made of the same material as compact objects, fall slower than the latter in a vacuum. When this was discovered a few years ago, some bewildered scientists tried to answer the surprising results by postulating a fifth fundamental force called “supergravity.” The same experiments also found a discrepancy in Newton’s famed inverse-square law, to the tune of 0.37%, quite innocuous to the average Joe on the street, but a gaping hole in the world of science.¹⁰⁰⁴

¹⁰⁰³ Many historians and scientists believe Aristotle did not hold that the heavier object falls faster; rather, he held the correct view that an object starting from a greater height will fall faster to the Earth than an object starting from a lesser height. The misunderstanding arises because Aristotle’s writings on this point are somewhat ambiguous. Nevertheless, if we were to understand the downward force on an object at rest at a certain height as equal to the force needed to keep it at that particular height, and if we assigned the term “weight” to this force as Aristotle did, then it would certainly be true that the “weight” of an object would be greater the faster it falls. Similarly, because falling objects accelerate, more force is required to stop a falling object than to hold the same object at rest.

¹⁰⁰⁴ D. R. Long, “Experimental Examination of the Gravitational Inverse Square Law,” *Nature*, April 1976, Vol. 260, pp. 417-418. More recently, experiments in pendulum behavior just prior to eclipses and within deep mine shafts have consistently presented severe anomalies in Relativity’s theory of gravitation (see *Physical Review D* 3, 823 and *General Relativity and Gravitation*, Vol. 24, No. 5, 1992, pp. 543-550; S. C. Holding and G. J. Tuck “A New Mine Determination of the Newtonian Gravitational Constant,” *Nature*, Vol. 307, Feb. 1984, pp. 714-716; D. R. Long, “Why Do We Believe Newtonian Gravitation at Laboratory Dimensions?” *Physical Review D* 9 (1974) 850-852; D. R. Mikkelsen, M. J. Newman, “Constraints on the Gravitational Constant at Large Distances,” *Physical Review*, D 16, 1977, 919-926; B. Schwarzschild, “From Mine Shafts to Cliffs: The ‘Fifth Force’ Remains Elusive,” *Physics Today*, July, 21, 1988; C. C. Speake et al., “Test of the Inverse-Square Law of Gravitation Using the 300 m Tower at Erie, Colorado,” *Physical Review Letters* 65, 1990b, 1967-1971; F. D. Stacey, G. J. Tuck, “Geophysical Evidence for Non-Newtonian Gravity,” *Nature* 292, 1981, 230-232; C.W. Stubbs et al, “Limits on Composition-Dependent Interactions Using a Laboratory Source: Is There a ‘fifth force’ Coupled to Isospin?” *Physical Review Letters* 62, 1989b, 609-612). Ephraim Fischbach, after analyzing the data from Eötvös experiments in the 1920s, which asserted that gravitational acceleration was independent of mass, concluded this was incorrect and that there was evidence of a limited composition-dependent “fifth force” that opposed gravity. His paper caused an uproar in the physics world (E. Fischbach, D. Sudarsky, A. Szafer, C. Talmage and S H. Aronson, *Physical Review Letters* 56, 3, 1986). Luigi Foschini, “Short Range Gravitational Fields: The Rise and Fall of the Fifth Force” (CNR Institute, 2002),

The Physical Cause of Gravity

Once we understand that space is not a vacuum but is filled with an ether composite consisting of minute particles from the size of electrons and positrons to the Planck dimensions or beyond, we have the basis upon which to offer a physical cause for gravity.

In the past, science understood the atom to be composed mostly of empty space, but that is no longer the accepted view. The protons, neutrons and electrons are now understood to compose a mere fraction of the total mass of the atom, the rest of the atom being comprised of the universal ether. As such, the ether is the primary building block of matter that holds everything together. The nucleon and its electrons are only particular distinctions in this vast ether sea.

The most important principle in determining the physical cause of gravity is to understand the specific relationship between the atom and the ether. That is, the ether penetrates the atom, but it does not penetrate either the nucleus or the electrons. This is not surprising in light of what we already know about atomic particles. Protons, for example, have been found to be virtually indestructible and they do not decay. So stable is the proton that experiments reveal its average lifetime must exceed 10^{32} years.¹⁰⁰⁵ Hence, in the atom the mass of the nucleon and its accompanying electrons is displacing a certain amount of the universal ether. In other words, the ether serves as the interstitial substance that fills the so-called “empty space” of the atom.

Now for the most important concept that will lead us to the cause of gravity: since the atomic particles are less dense than the ether yet

claims to have solved this problem. Others, such as Peter Saulsan of MIT, say that the “fifth force” does not disturb General Relativity since hypercharge has an approximate range of only 200 meters. Charles Brush has demonstrated that metals of high atomic weight and density fall slightly faster than those of lower atomic weight and density, even though the same mass of each metal is used; and that the weight of metals changes with its physical condition (Charles F. Brush, “Some new experiments in gravitation,” *Proceedings of the American Philosophy Society*, vol. 63, pp. 57-61, 1924). Victor Crémieu demonstrated that gravitation measured in water on the surface of the Earth is greater by one-tenth than that determined by Newton’s theory (Victor Crémieu, “Recherches sur la gravitation,” *Comptes Rendus de l’Académie des Sciences*, Dec. 1906, pp. 887-889). D. Kelly has shown that when the absorption capacity is reduced by magnetizing or electrically energizing a material body, it is attracted at a lesser rate by Earth’s gravity (Josef Hassleberger, “Comments on gravity drop tests performed by Donald Kelly,” *Nexus*, Dec. 1994 – Jan. 1995, pp. 48-49).

¹⁰⁰⁵ James S. Trefil, *The Moment of Creation: Big Bang Physics from Before the First Millisecond to the Present Universe*, New York: Scribner’s Sons, 1983, pp. 141-142. Although protons have been theorized to consist of other particles (e.g., leptons, quarks), nevertheless, in the cosmic realm the proton remains indestructible. Whereas 100 MeV is needed to remove an electron from an atom, and 10^6 MeV to remove protons from neutrons, it would take 10^{11} MeV to break down a proton. By comparison, the best modern accelerators can presently produce 10^{12} MeV.

occupy a definite position within the ether of the atom, this means that the total density of the ether within the atom will be less than the density of ether outside the atom. This imbalance will cause an ether vacuum between the inside and outside of the atom. Since nature abhors a vacuum, the ether will seek to distribute itself in order to eliminate the vacuum. *In short, the effort to eliminate the vacuum is the cause of gravity.* That is, the less-dense ether inside the atom will attempt to draw in the denser ether outside the atom (just as can of soda, having a less-dense volume of air inside of it will draw in the outside air as soon as the tab is opened). This vacuum force will continue until equilibrium is reached, but, in fact, equilibrium is never reached, and thus the force of gravity between the two objects persists indefinitely.

The next logical question is: of two objects, what makes the smaller object fall toward the larger object? The answer is simple. In Newton's case, for example, the apple falls to the Earth because the larger the mass, the stronger the vacuum. The Earth, which is the larger mass, will create a stronger ether vacuum than a smaller mass, and thus the smaller mass (the apple) will be drawn toward the larger mass by the force of the Earth's greater ether vacuum. The reason the Earth creates a greater ether vacuum than the apple is that the more atomic mass an object has, the less interstitial ether it will possess in its given volume, and thus the greater the imbalance it will have with the ether outside its mass. The Earth, having more mass than the apple, has less interstitial ether within its particular volume and thus a greater ether vacuum.

By the same principle, Jupiter will have more gravitational force than the Earth because Jupiter, having more atomic mass than Earth, will have less interstitial ether for its given volume, and thus create a greater ether vacuum, which then attempts to pull more forcefully the ether from outside the planet in order to reach equilibrium.

There are several observations we can posit from the ether-vacuum model of gravity:

- It explains why gravity is best understood as an “attractive” force, since the greater vacuum generated by the larger mass is forcing the smaller mass to be drawn toward it.
- It explains why gravity is a radial force. Since all material objects are curved, they will create an ether vacuum and attract objects outside of them based only on their radial geometry. Whereas Einstein claimed that matter curved space (and the curve was understood as the force of gravity); in reality, it is matter that is curved and which then attempts to pull in the “space” (ether) around itself at every point on its curved surface.
- It explains why, in the local environment, the intensity of gravity lessens with distance on a geometrical scale, that is, based on the

inverse square law. The tension caused by the imbalance of ether will lessen as the distance increases, since the farther material objects are from one another, the less imbalance of ether will exist between them.

- It explains why objects accelerate as they fall to Earth. The force from the vacuum in the ether is much greater than what the object can resist and therefore it falls. But since the object has a measure of resistance against the ether due to its specific atomic mass, the force of the ether vacuum, although pulling at one constant rate, will only gradually be able to bring that force upon the object. The more time available to bring the vacuum force upon the object (the time is more available by increasing the distance the object falls), the greater will be the object's acceleration.
- It explains why objects of differing mass placed at the same height will fall at the same rate of acceleration. The acceleration of an object is proportional to the amount of ether within the object and the resistance the object offers against the ether due to the object's mass. An object of more mass has less interstitial ether, but by the same token, because of its greater mass it has a greater resistance against being pulled by the vacuum of ether outside of its mass. Conversely, an object of less mass has more interstitial ether (and therefore the vacuum force is not as great), but less resistance (and therefore the vacuum will have an easier task moving it). All in all, the proportions balance completely so that large and small masses will fall at the same rate.
- It explains the "action-at-a-distance" phenomenon, that is, why gravity can stretch for long distances and react instantaneously. Since the extreme density of the ether, which is accentuated by its rotation, allows it to act as an absolute rigid body, and thus it will allow even the smallest vibrations to be transmitted speedily over long distances.
- It explains the relationship between gravity and inertia. Since a material object is constantly attempting to reach ethereal equilibrium with its environment, the force created by the constant effort is inertia. By the same token, since in the presence of no mass and thus no ether vacuum, the energy of a force applied to a material object will not diminish, thus the object will remain in motion unless compelled upon by a net external force. It is the ether that transmits the energy of the force, and the ether that also keeps it constant.

- It explains why atoms experience the Sagnac effect. Since the ether forms an interstitial environment throughout the atom, it will allow the electrons to circle the nucleus in absolute motion.

He stretches out the north over the void, and hangs the
earth upon nothing.
He binds up the waters in his thick clouds, and the cloud
is not rent under them.
He covers the face of the moon,
and spreads over it his cloud.
He has described a circle upon the face of the waters at
the boundary between light and darkness.

Job 26:7-10

"The current state of knowledge can be summarized thus: In the beginning, there was nothing, which exploded."

Terry Pratchett¹⁰⁰⁶

"The great power of science is its ability, through brutal objectivity, to reveal to us truth we did not anticipate."

Robert Laughlin¹⁰⁰⁷

"It is impossible to convince a person of any true thing that will cost him money."

Robert Laughlin¹⁰⁰⁸

"You cannot depend on your eyes when your imagination is out of focus."

Mark Twain¹⁰⁰⁹

¹⁰⁰⁶ Terry Pratchett, *Lords and Ladies*, New York, Harper Torch, 1996, p. 7.

¹⁰⁰⁷ Robert Laughlin, *A Different Universe, Reinventing Physics from the Bottom Down*, New York, Basic Books, 2005, p. xvi. Laughlin is a Nobel laureate in physics.

¹⁰⁰⁸ Robert Laughlin, *A Different Universe, Reinventing Physics from the Bottom Down*, New York, Basic Books, 2005, p. 114.

¹⁰⁰⁹ Twain's Notebook, 1898.

Chapter 9

How Old and How Big Is the Universe?

Modern Science and Atheistic Philosophy

One of the more popular endeavors of physicists and astronomers today is to design an accurate model of the origin, age, and size of the universe. Unfortunately, this is an area fraught with speculation and uncertainty. As John Horgan notes:

Cosmology, in spite of its close conjunction with particle physics, the most painstakingly precise of sciences, is far from being precise itself. That fact has been demonstrated by the persistent inability of astronomers to agree on a value for the Hubble constant, which is a measure of the size, age, and rate of expansion of the universe. To derive the Hubble constant, one must measure the breadth of the red shift of galaxies and their distance from the Earth. The former measurement is straightforward, but the latter is horrendously complicated. Astronomers cannot assume that the apparent brightness of a galaxy is proportional to its distance; the galaxy might be nearby, or it might simply be intrinsically bright....The debate over the Hubble constant offers an obvious lesson: even when performing a seemingly straightforward calculation, cosmologists must make various assumptions that can influence their results, they must interpret their data, just as evolutionary biologists and historians do. One should thus take with a large grain of salt any claims based on high precision....Our ability to describe the universe with simple, elegant models stems in large part from our lack of data, our ignorance. The more clearly we can see the universe in all its glorious detail, the more difficult it will be for us to explain with a simple theory how it came to be that way. Students of human history are well aware of this paradox, *but cosmologists may have a hard time accepting it.*¹⁰¹⁰

As modern science's interpretation of the Michelson-Morley experiment was made from the presupposition that the Earth was moving through space, so today, elaborate models of the universe are made from the presupposition that there is no center to the universe, and that the Earth is at least 4.5 billion years old in a universe at least 13.5 billion years old (which figure has decreased from the original 20 billion proposed only a decade ago). In cataloguing the theories of the universe that have appeared just in the last century, one witnesses a myriad of

¹⁰¹⁰ John Horgan, *The End of Science*, New York, Broadway Books, 1996, p. 111, emphasis added.

competing and often conflicting ideas, each one trying to reach the pinnacle with a “theory of everything” – the king of the hill that cannot be supplanted.

Much of the theorizing has been for the sole purpose of trying to make the universe self-sustaining, both in its origin and continuation. As we have pointed many times in our thesis, the main reason for modern science’s quest is to take God out of the picture. If by some over-arching “laws” of physics the universe can be understood to appear virtually out of nowhere and perpetuate itself indefinitely, science has accomplished its long awaited Nietzschean goal of making God’s existence superfluous. Such efforts are led by such icons as **Stephen Hawking** who, after making suggestions for the origin of the universe, concludes:

Thus all the complicated structures that we see in the universe might be explained by the no-boundary condition for the universe together with the uncertainty principle of quantum mechanics... So long as the universe had a beginning, we could suppose it had a creator. But if the universe is really completely self-contained, having no boundary or edge, it would have neither beginning nor end: it would simply be. *What place, then, for a creator?*¹⁰¹¹

“What place...for a creator?” Hawking shows that the pursuit of modern cosmology is not a casual endeavor but a full frontal assault on what was heretofore the exclusive domain of theology. Hawking even boasts of having circumvented a papal directive on the limits of cosmological speculation:

In 1981 my interest in questions about the origin and fate of the universe was reawakened when I attended a conference on cosmology organized by the Jesuits in the Vatican. The Catholic Church had made a bad mistake with Galileo when it tried to lay down the law on a question of science, declaring that the sun went around the Earth. Now, centuries later, it had decided to invite a number of experts to advise it on cosmology. At the end of the conference the participants were granted an audience with the pope. He told us that it was all right to study the evolution of the universe after the big bang, but we should not inquire into the big bang itself because that was the moment of Creation and therefore the work of God. I was glad then that he did not know the subject of the talk I had just given at the conference – the possibility that space-time was finite but had no boundary, which means that it had no beginning, no moment of Creation. I had no desire to share the fate of Galileo, with whom I feel a strong sense of identity,

¹⁰¹¹ *A Brief History of Time*, pp. 140-141, emphasis added.

partly because of the coincidence of having been born exactly 300 years after his death!¹⁰¹²

Beginning with the Copernican revolution, not only has cosmological science sought to correct the Church's so-called "outdated" medieval science, it seems to have no trepidation sticking its intrusive head into the sacred world of the divine. Hence, the forbidden fruit has been bitten once again, and the serpent is leading man into thinking that he can become a god and determine his own fate. As Carl Sagan gloated: "A universe that is infinitely old requires no Creator."¹⁰¹³ Fortunately, those of us who refuse to be swept away into the presumptuous boasts of modern science are comforted by the Scriptural words: "The fool hath said in his heart, 'There is no God.'"¹⁰¹⁴

If anyone thinks that cosmology is merely an issue of science, let him think again. These men are driven by ideology, and one of their chief goals is to rid the world of the notion of God and, most of all, of being morally responsible to anyone greater than themselves. Albert Einstein, for example, dismissed the existence of God based on his reluctance to submit himself to reward and punishment from a divine being whom he understood as a contradiction in terms. Although quite adept at joining space and time, Einstein refused to join divine sovereignty with human free agency and, therefore, rejected the notion of a personal God altogether. His journals also tell us that he had a deep resentment toward Catholic priests in general. The popular concept of Einstein as the meek and mild professor whose only desire was truth and who was merely indifferent to Christianity's claims is mere propaganda. In addition to his atheism, Einstein led quite an immoral life (See Appendix 9).

In the realm of science, Einstein knew precisely what was at stake in the experiments of Arago, Airy, Fizeau and Michelson-Morley. He realized that unless science could come up with a convincing counter-explanation, the whole world would be worshipping at the feet of the Catholic Church, for she had stood her ground in the seventeenth century against the Copernican revolution. That Einstein would invent his fantastic theories precisely for such an ulterior motive has been noted several times in this volume. His colleagues did much the same. Echoing the sentiments of Stephen Hawking are the words of Arthur Eddington (the one man who catapulted Einstein to fame by his selective use of eclipse photographs as Appendix 5 will show) regarding his motivations for theories of cosmological origins that he preferred:

¹⁰¹² *A Brief History of Time*, p. 116.

¹⁰¹³ Carl Sagan, *Cosmos*, Random House, 1980, p. 243.

¹⁰¹⁴ Psalm 14:1 [13:1].

The difficulty of applying this case [the cosmology of Lemaître] is that it seems to require a sudden and peculiar beginning of things...Philosophically, the notion of a beginning of the present order of Nature is repugnant to me...I should like to find a genuine loophole.¹⁰¹⁵

Considering that Eddington classed himself among an impeccable group of men that claimed to examine all scientific evidence objectively, we wonder how he and his colleagues allow “philosophy” to get into the mix to determine cosmological origins. Of course, we already know the answer to that question, since modern science has shown itself to be anything but objective, especially when it comes to the subject of origins.¹⁰¹⁶ Although Eddington does not reveal it here, the reason “a beginning is repugnant” to him is that it necessitates the existence of a Creator, a Being to whom Eddington would be held accountable for his actions. Indeed, that particular idea is “repugnant” to modern man.

Astronomer **Fred Hoyle**, who, as we have seen earlier, was quite candid in his support of the geocentric cause by saying that “...the difference between a heliocentric and a geocentric theory is one of motions only, and that such a difference has no physical significance,” is also quite frank about the philosophical motivations for preferring the former over the latter within a multi-billion year “Universe”:

The attribution of a definite age to the Universe, whatever it might be, is to exalt the concept of time above the Universe, and since the Universe is everything, this is crackpot in itself...God is identically equal to the universe.¹⁰¹⁷

¹⁰¹⁵ Arthur Eddington, “On the Instability of Einstein’s Spherical World,” in *Monthly Notices of the Royal Astronomical Society*, 90, 1930, p. 672; and “The End of the World: from the Standpoint of Mathematical Physics,” *Nature*, 127, 1931, p. 450, cited in *The Fingerprint of God*, p. 66.

¹⁰¹⁶ The lack of objectivity among modern scientists regarding origins was probably stated no better than by geneticist Richard Lewontin: “We take the side of science in spite of the patent absurdity of some of its constructs, in spite of its failure to fulfill many of its extravagant promises of health and life, in spite of the tolerance of the scientific community for unsubstantiated just-so stories, because we have a prior commitment, a commitment to materialism. It is not that the methods and institutions of science somehow compel us to accept a material explanation of the phenomenal world, but, on the contrary, that we are forced by our a priori adherence to material causes to create an apparatus of investigation and a set of concepts that produce material explanations, no matter how counterintuitive, no matter how mystifying to the uninitiated. Moreover, that materialism is absolute, for we cannot allow a Divine Foot in the door” (“Billions and Billions of Demons,” *The New York Review of Books*, January 9, 1997, pp. 28, 31).

These ideas, however, did not start with Einstein, Eddington, or Hawking. They are as old as the hills. Yet, we can trace the accelerated development of scientific atheism to the so-called “Enlightenment,” to the burgeoning philosophies and sciences that made it their objective to dethrone Christianity as the principal teacher of mankind. The lynch-pin of the whole affair, of course, was Copernican cosmology. Nothing could be accomplished until the Earth was removed from the center of the universe. Although the Copernicans never really won the war, and, in fact, the battle is still being fought in our present day, nevertheless, they have succeeded in giving the *impression* they have won. Impressions rule the hearts of men. As Lakatos puts it:

The Ptolemaists did their thing and the Copernicans did theirs and at the end the Copernicans scored a propaganda victory....Therefore the acceptance of the Copernican theory becomes a matter of metaphysical belief.¹⁰¹⁸

¹⁰¹⁷ Fred Hoyle, “The Universe: Past and Present Reflections,” *Annual Reviews of Astronomy and Astrophysics*, 20, 1982, p. 3; Fred Hoyle and Chandra Wickramasinghe, *Evolution From Space*, New York: Simon and Schuster, 1981, p. 143.

¹⁰¹⁸ Imre Lakatos and Elie Zahar, “Why Did Copernicus’ Research Program Supersede Ptolemy’s,” *The Copernican Achievement*, ed. Robert S. Westman, University of California Press, 1975, p. 367.

The Influence of Isaac Newton

The apparent victory was helped along by many philosophers and scientists, but some of the more prominent names include [Isaac Newton](#) (1642-1727) and [Immanuel Kant](#), the former in his book *Philosophiae Naturalis Principia Mathematica* in 1689, and the latter in his 1755 book *Universal Natural History and Theory of the Heavens*.¹⁰¹⁹ Following Thomas Digges (d. 1595), Isaac Newton proposed that the universe was infinite. This idea was directly contrary to what had been taught for the first 1500 years of the Christian era. As Clark puts it:

The comfortable idea of a finite universe with the Earth at its center had been suspect from the beginning of the scientific renaissance and had finally been abandoned with the coming of Newton.¹⁰²⁰

Newton's popularity among scientists helped make the concept of an infinite universe immediately acceptable, although he did have a formidable opponent in [Gottfried Leibniz](#). Because Newton's views of the natural world were formed from a mixture of physical principles and spiritual intuition, Newton often explained the anomalies of his system by appealing to divine intrusion, something for which Leibniz severely criticized him.¹⁰²¹ Newton also dabbled in alchemy and the occult and these had a great effect on his worldview. As biographer Michael White concluded: "My conclusion is unequivocal: the influence of Newton's researches in alchemy was the key to his world-changing discoveries in science. His alchemical work and his science were inextricably linked."¹⁰²²

¹⁰¹⁹ Immanuel Kant, *Universal Natural History and Theory of the Heavens, Theories of the Heavens*, editor Milton K. Munitz, Glencoe, IL: Free Press, 1957.

¹⁰²⁰ *Einstein: The Life and Times*, p. 266. Clark adds: "As Einstein wrestled with the cosmological implications of the General Theory, the first of these alternatives, the Earth-centered universe of the Middle Ages, was effectively ruled out." Clark, however, cites no reason for ruling out the Earth-centered universe.

¹⁰²¹ Leibniz writes: "Sir Isaac Newton, and his followers, have also a very odd opinion concerning the work of God. According to their doctrine, God almighty needs to wind up his watch from time to time; otherwise it would cease to move. He had not, it seems sufficient foresight to make it a perpetual motion. Nay, the machine of God's making, is so imperfect, according to these gentlemen, that he is obliged to clean it now and then by an extraordinary concourse, and even to mend it, as a clockmaker mends his work; who must consequently be so much the more unskillful a workman, as he is often obliged to mend his work and set it right. According to my opinion, the same force and vigour remains always in the world, and only passes from one part to another, agreeably to the laws of nature, and the beautiful pre-established order..." (Philip P. Wiener, editor, *Leibniz Selections*, New York: Charles Scribner's Sons, 1951, pp. 216-217).

¹⁰²² Michael White, *Isaac Newton: The Last Sorcerer*, Great Britain: Perseus Books, 1997, p. 5.

As we noted earlier, Newton made no definitive claim to understanding the sole cause of gravity, and, like many of his colleagues, he shifted from supposing it was caused by the inherent nature of matter, to the existence of ether, to the imposition of God. In fact, Newton found the interactions of gravity between the sun and the planets so complicated that he thought God had to adjust them quite frequently to keep things stable.¹⁰²³ Although his inverse square law certainly helped science predict the effects of gravity, the principle wherein the intensity of a given energy dissipates four-fold for every doubling of the distance is a simple geometric phenomenon that occurs in spherically radiating entities, whether it be light, sound, gas, or gravity. The concentration of the substance will decrease because the area in which it spreads has increased. Kepler had discovered it for light, Newton for gravity. In effect, Newton merely discovered the geometry of gravity, but nothing about its origin or nature.

Newton's concept of gravity is important for one very significant reason – it determines his view of the universe. Newton believed that a finite and bounded universe (i.e., one possessing an edge) would “fall down into the middle of the whole space, and there compose one great spherical mass.” He thus proposed that an infinite universe would allow “the fixed stars, being equally spread out in all points of the heavens, to cancel out their mutual pulls by opposite attractions.” In other words, Newton needed an infinite universe so that the universe would not collapse in on itself. Thus, in a letter to [Richard Bentley](#) in 1692, Newton wrote:

It seems to me, that if the matter of our sun and planets, and all the matter of the universe, were evenly scattered through all the heavens, and every particle had an innate gravity towards all the rest, and the whole space throughout which this matter was scattered, was finite, the matter on the outside of this would by its gravity tend towards all the matter on the inside, and by

¹⁰²³ Ivars Peterson, *Newton's Clock: Chaos in the Solar System*, New York: W. H. Freeman and Co. 1993, pp. 16, 226. Peterson writes: “The tangle of mutual gravitational interactions exhibited by the known planets and the sun was so complex that no complete mathematical solution seemed possible. Newton himself had noted certain irregularities in the movements of the planets that he suspected could lead to the disruption of the solar system unless orbits were, in effect, reset at strategic moments. He concluded that divine intervention was periodically necessary to maintain the system's equanimity.” Newton stated: “God...is himself the author and continual preserver of original forces or moving powers...[it is]...not a diminution, but the true glory of His workmanship, that nothing is done without his continual government and inspection. The notion of the world's being a great machine, going on without the interposition of God, as a clock continues to go without the assistance of a clockmaker, is the notion of materialism and fate, and tends to exclude providence and God's government in reality out of the world” (*Introduction to Concepts and Theories in Physical Science*, Gerald Holton, p. 284).

consequence fall down into the middle of the whole space, and there compose one great spherical mass. But, if the matter were evenly disposed throughout an infinite space, it could never convene into one mass, but some of it would convene into one mass and some into another, so as to make an infinite number of great masses, scattered great distances from one to another throughout all that infinite space. And thus might the sun and fixed stars be formed, supposing the matter were of a lucid nature.¹⁰²⁴

What distinguished Newton's physics from modern physics is his notion of absolute space and time, which were independent of gravity, whereas Einstein held that space and time were relative and created by gravity, which was in turn created by mass. Newton held that God placed the stars and planets into absolute space and time, while Einstein held that stars and planets evolved and subsequently created space and time. Newton never did explain, however, how there could be absolute space and time in an infinite universe.

Although he believed in physical absolutes and God's providence in guiding the mechanical workings of the universe, we also see in Newton someone who is desperately struggling to make sense out of a temporal world he has constructed and which contains an impenetrable barrier between itself and the absolutes. In effect, Newton's absolutes become nothing more than Platonic images that have only a chimera of reflection in the acentric and infinite cosmos he inherited from Galileo, Digges and Bruno. In this he shows us the dilemma of modern man. He writes:

Absolute space, in its own nature, without relation to anything external, remains always similar and immovable. Relative space is some movable dimension or measure of the absolute spaces, which our senses determine by its position to bodies and which is commonly taken for immovable space; such is the dimension of a subterraneous, an aerial, or celestial space, determined by its position in respect of the Earth. Absolute and relative space are the same in figure and magnitude, but they do not remain always numerically the same. For if the Earth, for instance, moves, a space of our air, which relatively and in respect of the Earth remains always the same, will at one time be one part of the absolute space into which the air passes; at another time it will be another part of the same, and so, absolutely understood, it will be continually changed.¹⁰²⁵

¹⁰²⁴ Isaac Newton, "To the Reverend Dr. Richard Bentley, at the Bishop of Worcester's House, Park Street, Westminster from Cambridge, December 10, 1692," in *Theories of the Universe*, Milton K. Munitz, Glencoe, IL: Free Press, 1957.

¹⁰²⁵ *Philosophiae Naturalis Principia Mathematica*, 2, trans. Andrew Motte, 1729, revised, Florian Cajori, Berkeley: University of California Press, 1934.

With an Earth in motion, Newton is forced to give us two worlds, one absolute and one relative, and the Copernican dilemma is perpetuated:

But real, absolute rest is the continuance of the body in the same part of that immovable space in which the ship itself, its cavity, and all that it contains is moved. Wherefore, if the Earth is really at rest, the body, which relatively rests in the ship, will really and absolutely move with the same velocity which the ship has on the Earth. But if the Earth also moves, the true and absolute motion of the body will arise, partly from the true motion of the Earth in immovable space, partly from the relative motion of the ship on the Earth.¹⁰²⁶

He only wishes it could be resolved, but knows that it cannot be:

And so, instead of absolute places and motions, we use relative ones, and that without any inconvenience in common affairs; but in philosophical disquisitions, we ought to abstract from our senses and consider things themselves, distinct from what are only sensible measures of them. For it may be that there is no body really at rest to which the places and motions of others may be referred.

But we may distinguish rest and motion, absolute and relative, one from the other by their properties, causes, and effects. It is a property of rest that bodies really at rest do rest in respect to one another. And therefore, as it is possible that in the remote regions of the fixed stars, or perhaps far beyond them, there may be some body absolutely at rest, but impossible to know from the position of bodies to one another in our regions whether any of these do keep the same position to that remote body, it follows that absolute rest cannot be determined from the position of bodies in our regions.¹⁰²⁷

The only thing Newton musters to make some sense of his inherited acentric world is reliance on “true motion” determined by “force,” but in the end this is also conditional and uncertain:

It is indeed a matter of great difficulty to discover and effectually to distinguish the true motions of particular bodies from the apparent, because the parts of that immovable space in which those motions are performed do by no means come under the observation of our senses. Yet the thing is not

¹⁰²⁶ *Philosophiae Naturalis Principia Mathematica*, 4.

¹⁰²⁷ *Philosophiae Naturalis Principia Mathematica*, 4

altogether desperate; for we have some arguments to guide us, partly from the apparent motions, which are the differences of the true motions; partly from the forces, which are the causes and effects of the true motions.¹⁰²⁸

Before we leave Newton, we need to reiterate what his “laws” of motion allowed and disallowed regarding the geocentric/heliocentric issue. It is a common presumption that Newton’s laws of motion paved the way for the demise of the geocentric view, and that [Johannes Kepler](#) put the final nails into the coffin since he “fixed” the Copernican/Galilean solar system by replacing circular orbits with elliptical orbits. This is quite a misconception, however. Although it is true in the local system of our sun and planets that Newton’s laws would require the latter to revolve around the former; and Kepler’s laws showed mathematically how the planets kept pace with observations; this did not mean, contrary to Kepler, that the sun was the center of the solar system. Kepler believed the sun was the center based on his idea of “mystical harmonics” and other such esoteric beliefs. His goal was to give the sun a privileged position, bestowing it with almost divine qualities.¹⁰²⁹ As noted previously, Kepler’s goal was directly contrary to the desires of [Tycho Brahe](#) from whom Kepler confiscated the data for his calculations of planetary motion. Brahe was a devout geocentrist and he implored Kepler to use his meticulous notations to continue supporting the geocentric system. Kepler, under pressure from other influences, forsook the promise he made to Brahe and adopted the heliocentric system.

In any case, it has been commonly interpolated from Newton’s and Kepler’s laws that the smaller body (e.g., a planet) must revolve around the larger body (e.g., the sun) due to the greater mass of the latter. The truth is, however, that none of the planets revolve around the sun; rather, both the sun and the planets revolve around what Newton called the “center of mass,” which, in turn, corrected Kepler’s third law of planetary motion.¹⁰³⁰ Although it is true that, because the sun is so

¹⁰²⁸ *Philosophiae Naturalis Principia Mathematica*, 4

¹⁰²⁹ Kepler writes: “The sun in the middle of the moving stars, himself at rest and yet the source of motion, carries the image of God the Father and Creator....He distributes his motive force through a medium which contains the moving bodies even as the Father creates through the Holy Ghost” (Letter to Michael Maestlin, October 3, 1595, *Gesammelte Werke*, vol. xiii, p. 33, cited in *The Sleepwalkers*, p. 264). “Geometry existed before the Creation, is co-eternal with the mind of God, is God himself (what exists in God that is not God himself?)...” (Kepler’s 1618 work *Harmonice Mundi*, Lib. IV, Casper’s Biography, I., *Gesammelte Werke*, vol. vi).

¹⁰³⁰ Kepler’s third law, which took him twenty-two years to complete, is simply $P^2 = R^3$. Here P is the planet’s orbital period (measured in sidereal years) and R is the semi-major axis (the distance between the planet and the sun). The Third Law is stated in his *Harmonice Mundi* (Harmony of the World) in the original Latin as: “Sed res est certissima exactissimaque, quod proportio, quae est inter binorum quorumconque

massive compared to the planets that the “center of mass” will be near the center of the sun, the fact remains that it is technically incorrect to say that the smaller body revolves around the larger body. This principle becomes critically important when, for example, we are considering more than two bodies in the system. Our solar system has eight planets and a belt of asteroids to contend against the sun.¹⁰³¹ As Charles Lane Poor describes it:

Now so long as there are but two bodies in the system, these six elements are constant, and the smaller body will travel for ever around and around in its unvarying path. From these elements the actual position of the body at any time, past, present, or future, can be calculated by very simple formulas. If, however, a third body be introduced into our ideal universe, then the motions of the bodies are no longer simple and easily calculated. In fact, the paths of the three bodies become so complicated as to defy any mathematical description. Newton failed to find a solution to this problem; and every mathematician since his time has likewise failed.¹⁰³²

Ivars Peterson gives another view:

[T]he problem of the solar system’s stability has fascinated and tormented astronomers and mathematicians for more than 200 years. Somewhat to the embarrassment of contemporary

planetarum tempora periodica, sit praecise sesquialtera proportionis mediarum distantiarum, id est orbium ipsorum” (V, 3, Prop. 8). For Mercury, $P = 0.24$ years and $R = 0.39$ astronomical units, which makes $P^2 = 0.06$ and $R^3 = 0.06$. The other planets are close to the ratio, but not exact. For Venus, $P = 0.62$ and $R = 0.72$, then $P^2 = 0.39$ and $R^3 = 0.37$. For Mars, $P = 1.88$ and $R = 1.52$, then $P^2 = 3.53$ and $R^3 = 3.51$. For Jupiter, $P = 11.9$ and $R = 5.20$, then $P^2 = 142$ and $R^3 = 141$. For Saturn, $P = 29.5$ and $R = 9.54$, then $P^2 = 870$ and $R^3 = 868$. For Uranus, $P = 84$ and $R = 19.191$, then $P^2 = 7056$ and $R^3 = 7068$. For Neptune, $P = 165$ and $R = 30.071$, then $P^2 = 27225$ and $R^3 = 27192$. For Pluto, $P = 248$ and $R = 39.457$, then $P^2 = 61504$ and $R^3 = 61429$. Kepler’s original application of the Third Law was not quite accurate. Kepler, for example, calculated Saturn’s semi-major axis to be 9 A.U. The cube is 729. The square root of 729 is 27, thus the orbital period of Saturn would be 27 years, but this is off by three years, since Saturn revolves around the sun in 30 years (*The Sleepwalkers*, p. 399). Newton modified Kepler’s third law to: $(m_1 + m_2) P^2 = (d_1 + d_2)^3 = R^3$, in which m is the mass of the bodies, and d is the distance from each other.

¹⁰³¹ In the geocentric system, the Earth is not considered a planet. “Planet” comes from the Greek word *πλανήτης* meaning “wandering star,” denoting that a planet is a body in constant motion. Since Earth is motionless, it is not counted among the planets.

¹⁰³² Charles Lane Poor, *Gravitation versus Relativity*, p. 122. Regarding the three-body problem, in 1912, K. F. Sundman attempted a solution based on a converging infinite series, but it converges much too slowly to be of any practical use. As it stands, no method has been developed to solve the equations of motion for a system with four or more bodies.

experts, it remains one of the most perplexing, unsolved issues in celestial mechanics. Each step toward resolving this and related questions has only exposed additional uncertainties and even deeper mysteries. The crux of the matter hinges on the fact that it is one thing to write down the equations expressing the laws of motion and a totally different thing to solve those equations. As Newton and his successors quickly discovered, computing the motions of the planets and other bodies in the solar system is no simple matter. In fact, the computations are often so complex that researchers now use supercomputers...to solve them.¹⁰³³

This complexity is one reason Newton believed that God had to intervene frequently in order to “fix” the solar system.¹⁰³⁴ But it is also another reason to reject the claim that the Copernican-Keplerian-Newtonian system wins the day because “it is so simple.” Simple it is not. The epicycles of Ptolemy are child’s play compared to the Newtonian model that must depend on integral and differential calculus to come even marginally close to explaining the perturbations among the planets and moons. [Leonhard Euler](#) stated he was overwhelmed in merely accounting for the moon’s motion around the Earth, consequently concluding it to be impossible to predict all the perturbations of the entire solar system. [Henri Poincaré](#) also became quite involved in these calculations. He more or less revamped all previous methods but concluded that

[A]lthough the equations representing three gravitationally interacting bodies yield a well-defined relationship between

¹⁰³³ Ivars Peterson, *Newton’s Clock: Chaos in the Solar System*, p. 9. Considering that “super computers” must be employed to rescue man from the failure of Newton’s theory to account for the complex motion of the planets, this inevitably leads to the suspicion that Joseph L. Adams’ and Urbain J. J. Leverrier’s discovery of Neptune as “the final proof of the universal application of Newton’s law of gravitation” (as claimed by Morris Kline in *Mathematics and Western Culture*, p. 244) was highly unlikely in 1846. Their “discovery” of Neptune may have been as fortuitous as Jonathan Swift’s guess in 1720 in *Gulliver’s Travels*, or Kepler’s guess in 1610, that if Jupiter had four moons and Earth had one, then Mars had two moons, but which was not verified by observation until 1877. This may be the reason that Wilfred de Fonvielle, to whom Leverrier displayed his calculations, remarked: “What if all that were not mere humbug” (cited in Arthur Lynch’s *The Case Against Einstein*, p. 160, note). The same may be true for Percival Lowell’s (d. 1916) guess that another planet (Pluto) existed due to perturbations in the orbits of Neptune and Uranus, since after astronomers observed Pluto through a telescope in 1930, it was also discovered that Lowell’s calculations were based on fallacious data. I am indebted to N. Martin Gwynne for these astute observations.

¹⁰³⁴ As Koestler writes: “He further believed that under the pressure of gravity the universe would collapse ‘without a divine power to support it’; and moreover, that the small irregularities in the planetary motion would accumulate and throw the whole system out of gear if God did not from time to time set it right” (*The Sleepwalkers*, p. 536).

time and position, there exists no all-purpose, computational shortcut – no magic formula – for making accurate predictions of position far into the future.¹⁰³⁵

From these observations, it was Poincaré who produced what science now calls “dynamical chaos.” In the end, Poincaré left Newton’s laws of motion unchanged, but he radically altered our understanding of the types of behavior they mandate:

The true goal of celestial mechanics is not the calculation of the ephemerides [tables of the locations of planets] but rather to discover if all phenomena can be explained by Newton’s laws.¹⁰³⁶

The point of all this is to show that, not only are the movements of the heavenly bodies quite complex, it is necessary to account for all the bodies in a given system in order to know the trajectory of their motions. In this light, since Newton’s laws of motion are not based on the idea that a smaller body revolves around a larger body but that bodies revolve around a center of mass, Newton’s laws also require that, if the masses of all the heavenly bodies and the distances between each of them are taken into consideration, there will be one center of mass among them. As we will see, when all the mass of the universe is taken into account, it is no stretch of the imagination to understand that Earth could be at the center of this gigantic mass. We cover this subject in more detail in Chapter 10.

¹⁰³⁵ Ivars Paterson, *Newton’s Clock*, pp. 159-160.

¹⁰³⁶ Henri Poincaré, *New Methods of Celestial Mechanics*, ed. Daniel L. Goroff, New York: American Institute of Physics, 1993, Introduction. Poincaré’s words are quite apropos in our day, since there have been so many puzzling movements in space, from that of Saturn’s moon Hyperion to those of man-made satellites. Evidences of anomalies in Newton’s theory suggested themselves when scientists discovered that *Pioneer 10* “seems to be defying the laws of gravity. [It] has been slowing down, as if the gravitational pull on it from the sun is growing progressively stronger the farther away it gets” (Michael Nieto, *Discover*, October, 2003, p. 36). The same anomaly was noticed of *Pioneer 11*, as well as the *Ulysses* and *Galileo* probes.

The Influence of Immanuel Kant

Left with only the image of absolutes but the reality of relativism, the wall erected by Copernicus and Newton was made impenetrable by [Immanuel Kant](#). After Kant's wrecking ball, man couldn't know anything about the absolute, let alone use it to cope with his existence. In his famous *Critique of Pure Reason*,¹⁰³⁷ as well as *Religion Within the Limits of Reason Alone*,¹⁰³⁸ Kant did away with absolutes, innate ideas (from God), miracles, and just about anything that the medieval theologians had assumed was divinely sacrosanct. Moreover, Kant was influential in many areas of thought, since as a general rule, philosophy has a tendency to filter down over time into the arts, culture, and sciences, thus creating paradigms and superstructures to undergird all the other disciplines.

Kant had convinced the world that he had, indeed, demolished Augustine's and Aquinas' proofs for the existence of God. Things were never quite the same afterward. Although from the Enlightenment's perspective Kant appeared to give vitality and freedom to man's thought, in reality, he put man on the downward slope from which he has not yet recovered, and may never recover. So pervasive was Kant's philosophy that he convinced mankind it could know nothing of the material world for certain, since, as he taught, everything man experienced was made such only by the *a priori* "categories of the mind," over which he had no control.

Most people are not aware of the fact that Kant's cosmology had as much influence on man's thinking as his philosophy, enough for him to be called "the father of modern cosmology."¹⁰³⁹ In writing the *Critique of Pure Reason*, Kant reveals that he came to the position of demoting pure reason due to two "proofs" about the construction of the universe.¹⁰⁴⁰ In the first, Kant argues that the world must have had a

¹⁰³⁷ Immanuel Kant, "Critique of Pure Reason," *Great Books of the Western World*, vol. 42, ed., Robert Maynard Hutchins, Chicago: *Encyclopedia Britannica*, 1952.

¹⁰³⁸ Immanuel Kant, *Religion Within the Limits of Pure Reason Alone*, trans. T. M. Green and H. H. Hudson, New York, Harper and Row, 1960.

¹⁰³⁹ Kant wrote the *Natural History and Theory of the Heavens* in 1755 and the *Metaphysical Foundations of Natural Science* in 1786, both of which held Newton's laws of motion and the celestial mechanics of Copernicanism in the greatest esteem. At the same time, however, he was the first to point out that Newton's laws, contrary to what Newton asserted, could not be derived from observation, and thus Kant refuted the "Baconian myth" that science begins only with observations. As Popper argues: "Newton's dynamics goes essentially beyond all observations. It is universal, exact and abstract; it arose historically out of myths; and we can show by purely logical means that it is not derivable from observation-statements" (*Conjectures and Refutations*, p. 190). Kant's mistake, of course, was his *a-posteriori* belief that Newtonian mechanics is irrefutable.

beginning in time, otherwise, at the present time, an infinite number of years would have already elapsed, but that is impossible, thus our reasoning capabilities are inadequate to escape the contradiction. The second proof involves the concept of “empty time” before the world existed. An empty time consists of nothing, and thus it cannot have any differentiation between time intervals. But there is a moment just prior to the beginning of the world, which is differentiated from all previous empty time because of its proximity to the beginning of the world. But if this proximity to the world is supposed to be as empty as the previous intervals, then we have a contradiction, and thus our reasoning fails again. Thus Kant has “critiqued” pure reason so that it cannot serve as a foundation.

These unsolvable contradictions Kant called “antinomies.” He concluded that our concepts of space and time are not applicable to the universe at large. Although we can apply space and time to ordinary events, Kant insisted that space and time are not real in themselves and are merely products of our mental intuition that we use to attempt to understand the universe. The only proper use of our mental abilities is as instruments of observation, a frame of reference, as it were, for our limited experience. Therefore, if we misapply space and time to issues that transcend our experience (as demonstrated in the two proofs above), our concepts will break down, and thus “pure reason,” that is, reason without reliance on our limited sense experience, is impossible.¹⁰⁴¹

Another contribution of Kant’s was his “primal nebula” theory, which was, in many respects, the proto-type to the modern Big Bang theory. It held that the universe evolved by a gradual formation of galaxies and planets from a collection of molecules in random motion, a process that would continue *ad infinitum*. This was a subtle yet “scientific” attempt to minimize the role of God, while natural forces, with a seeming mind of their own, formed the complex and life-sustaining elements of the universe. For Kant, it was impossible to know anything about the origins of these random particles since, if a divine being created them, the question of his existence was beyond man’s capabilities. All in all, Kant gave mankind a strictly mechanistic universe, with no beginning and no end, and, as a proto-Einstein, he introduced the concept that time and space are relative with no absolute counterpart.¹⁰⁴² Kant led science in the direction of a mechanized, impersonal and relativistic universe, and thus he served as a mentor to Einstein. As Arthur Miller notes:

Seelig (1952) writes that while at Aarau, Einstein did not participate in any of the numerous beer parties because he took

¹⁰⁴⁰ *Critique of Pure Reason*, p. 454 ff.

¹⁰⁴¹ *Critique of Pure Reason*, p. 518ff.

¹⁰⁴² *Albert Einstein’s Special Theory of Relativity*, p. 170.

seriously Bismarck's advice that "beer makes one dumb and lazy." Instead, continued Seelig, Einstein became "intoxicated on Kant's *Critique of Pure Reason*." Max Talmey, a medical student who dined weekly with the Einstein family, introduced the thirteen-year old Albert to Kant's writings. Talmey recalled that "Kant's works, incomprehensible to ordinary mortals, seemed clear to him."

Infinite Problems with an Infinite Universe

Olbers' Paradox

As we saw with science's problematic attempts to interpret the experiments both of stellar aberration and interferometry by means of a heliocentric model, so too, the infinite universe that was proposed to house the celestial bodies had grave problems. A survey of the data allows us to safely conclude that all attempts to make the universe infinite were for the express purpose of escaping the inevitability of having a center of absolute rest. A finite universe implies a center, and the data allowed little escape from this conclusion. As James Trefil sees the connection:

By the first years of the twentieth century, astronomers using very clever statistical tools had found that the universe, as we recognized it, was indeed finite. *We were sensibly near the center.*¹⁰⁴³

One of the more serious and still unsolved problems dictating against an infinite universe is what has come to be known as Olbers' Paradox. Actually, astronomer [Edmund Halley](#), a contemporary of Newton and with whom the latter corresponded quite frequently, discovered the paradox before Olbers. In 1715 Halley reasoned that if the universe were infinite, it would contain an infinite number of stars, which then meant that the night sky should be as bright as daylight. In fact, the entire face of the sky should look as bright as the sun, as if there were thousands of suns in the sky, overlapping each other so that no space would be without light. This paradox was such a glaring problem that no one even proposed a solution for three decades. The first was P. L. de Cheseaux in 1744, and not until almost a century later by [Heinrich W. M. Olbers](#) in 1823.¹⁰⁴⁴ To resolve the problem, both scientists proposed that a substance (i.e., dust) existed in interstellar space that was absorbing the immense light from the stars, which therefore made the night sky dark. By the late 1800s, however, science discovered through the works of Josef Stefan and [Ludwig Boltzmann](#) that matter seeks a point of equilibrium with its environment, and in order to reach that point, it will dissipate as much energy as it consumes. If not, it will build up heat, and if the heat reaches a critical level, the matter will deteriorate. Even if the light were to transpose into infrared radiation, it would still reach Earth. Moreover, even if there were a number of dust particles that reflected light away from the Earth, there would be a proportionate

¹⁰⁴³ James S. Trefil, *Space Time Infinity*, New York, Pantheon Books, 1985, p. 61.

¹⁰⁴⁴ J. D. North, *The Measure of the Universe*, Oxford, Clarendon Press, 1965.

amount that would reflect light toward the Earth, with the net result being the same. This scattering effect of light is the same reason why on a cloudy day we cannot readily determine the location of the sun. These facts discounted Olbers' explanation, and thus the dark night sky remained a "paradox."¹⁰⁴⁵ Except for one brief attempt to revive Olbers' explanation (which was proposed in 1930 by Robert Trumpler)¹⁰⁴⁶ the astronomical community, either by design or by accident, failed to apply Boltzmann's principles of radiation emission to their quest for the infinite universe until the advent of [Hermann Bondi's](#) "Steady State" theory in 1960. Bondi proposed that the energy from the stars was transformed into matter. Logically, if radiation became matter (thanks to $E = mc^2$), then Olbers' Paradox could be solved, since the excess radiation would now have an inexhaustible repository.¹⁰⁴⁷ As Stephen Hawking explains it:

The steady state theory required a modification of general relativity to allow for the continual creation of matter, but the rate that was involved was so low (about one particle per cubic kilometer per year) that it was not in conflict with experiment.¹⁰⁴⁸

We note how Hawking shows no compunction for the fact that science was willing to modify one of its most sacrosanct theories (i.e.,

¹⁰⁴⁵ As Stephen Hawking describes it: "Further evidence was provided by the so-called second law of thermodynamics, formulated by the German physicist Ludwig Boltzmann. It states that the total amount of disorder in the universe (which is measured by a quantity called entropy) always increases with time. This, like the argument about human progress, suggests that the universe can have been going only for a finite time. Otherwise, it would by now have degenerated into a state of complete disorder, in which everything would be at the same temperature" (*Black Holes and Baby Universes and Other Essays*, New York, Bantam Books, 1994, p. 87). According to John Ross of Harvard: "Ordinarily the second law is stated for isolated systems, but the second law applies equally well to open systems..." (*Chemical and Engineering News*, July 27, 1980, p. 40).

¹⁰⁴⁶ Trumpler discovered the existence of interstellar dust and, after comparing the angular sizes and brightness of globular clusters, reasoned that the dust was absorbing radiation. He also found that distant star clusters were bigger than nearby clusters, and he postulated that this was due to interstellar dust, which absorbed radiation from the distant clusters and thus made them appear fainter and more distant. Dust grains absorb optical photons. The energy carried by those photons cannot vanish. Instead, it must heat the dust grains. Since grains are solid, then upon becoming heated they will radiate a blackbody spectrum. For typical grain sizes of a micron or so, and the observed spectrum of the interstellar radiation field, one can derive typical grain temperatures by applying Wein's law. The emission properties of grains determine the general chemical composition of the dust: Ices (water ice, CO₂, etc.), graphite, silicates, iron.

¹⁰⁴⁷ Hermann Bondi, *Cosmology*, Cambridge University Press, 1960, pp. 20-22.

¹⁰⁴⁸ Stephen Hawking, *A Brief History of Time*, p. 47.

General Relativity) to make room for Bondi's explanation for Olbers' paradox.¹⁰⁴⁹ It wasn't enough that no one had ever proved that energy could create matter, but now they were going to make sure that the factory never stopped producing it. None of this seems to bother Hawking, for, as he states: "the rate...was so low." This is the same sort of preferred logic that String theorists give for the reason why virtual particles, which are said to "pop in and out of existence," do not violate the First Law of Thermodynamics, that is, simply because they are "gone in a flash."¹⁰⁵⁰

Various modern cosmologists attempt to explain Olbers' paradox by asserting: (a) if the galaxies are receding from us, then much of their light is red-shifted and thus the energy of the light is undetectable; (b) if the universe was created in the Big Bang, the light from the most distant stars has not had enough time to reach us, and (c) the expansion of the universe will dissipate starlight. All these proposals, however, are based on question-begging speculations. First, there is no proof that galaxies are receding from us since redshift has not been proven to be a measure of either distance or velocity, and even if it were, how would one know that the light has been redshifted if the energy is "undetectable"? If it is undetectable (and thus produces a dark sky) this could just as well be the case because the energy does not exist. Second, it is illogical to argue that light from distant stars has not yet reached the Earth, since in an infinite universe there would be an infinite number of star generations, making an infinite amount of light in the universe. Third, an expanding universe cannot alter the first law of thermodynamics, which currently holds that energy can neither be created nor destroyed. If in some way starlight loses its energy, the energy still exists in another form and place, and it will find its way to Earth, nonetheless.¹⁰⁵¹ In the end, the

¹⁰⁴⁹ "Modification" of the General Theory is quite a presumptuous undertaking by Hawking since it was Einstein who desired to solve Olber's paradox through General Relativity. As Clark writes: "The reasons for rejecting the Newtonian universe can be simply understood...For it seemed mathematically clear that the effect of an infinite number of stars would, even at infinite distances, produce an infinitely strong force whose effect would be to give the stars a high velocity through the universe...Einstein was therefore forced to consider whether it was possible to conceive of a universe that would contain a finite number of stars distributed equally through unbounded space. His answer to the apparent contradiction lay in the idea that matter itself produced the curvature of space" (*Einstein: The Life and Times*, pp. 267-268).

¹⁰⁵⁰ The First Law of Thermodynamics previously held that neither matter nor energy can be created or destroyed, which has since eliminated matter from the Law.

¹⁰⁵¹ Even those hoping for a resolution to Olber's paradox admit the poor history of its attempted resolutions, and specifically the dubiousness of the "expanding universe" solution. Paul Wesson states: "For most combinations of the cosmological model, galaxy formation redshift and galaxy evolution, the expansion only reduces the intensity by a factor of about 3-4...This confirms the conclusion drawn from earlier bolometric calculations of the extragalactic background light by Wesson, Valle, and Stabell, and shows Harrison is right about Olber's paradox. Contrary to what is implied

infinite universe acts precisely the opposite that its inventors intended it to work.

Gravity's Paradox

Meanwhile, problems for the concept of an infinite universe were just beginning. Since, as noted above, an infinite universe would produce an infinite amount of electromagnetic radiation, then by the same principle the universe would produce an infinite amount of every other transmittable phenomenon of nature, including gravity. Gravity would be especially troublesome since no one could possibly suggest that its effects would be minimized by “absorption from cosmic dust.” Gravity knows no barriers and has no limits. Ironically, Newton’s attempt to save the collapse of the universe by proposing that it be infinite is the very thing that would cause it to collapse. Although this obvious bit of logic completely escaped the mind of Newton, scientists about two hundred years after him became very aware of the problem gravity presented, but didn’t know quite what to do about it. Rather than abandon the infinite universe, they concocted “repulsive forces” by reworking Newton’s equations so as to counteract the “infinite” force of gravity. Here we see the same fudging of numbers that Hawking’s colleagues applied to Bondi’s theory. In this case, the dubious distinction belongs to Hugo von Seeliger, J. C. Kapteyn and Carl Neumann.¹⁰⁵²

in some books, the latter is not resolved mainly by the cosmological redshift. The darkness of intergalactic space is a result primarily of the finite age of the galaxies, in conjunction with other factors including the finite speed of light, and only secondarily of the expansion of the universe (“Olber’s Paradox and the Spectral Intensity of the Extragalactic Background Light,” *The Astrophysical Journal*, 367:399-406, February, 1991). We must add, however, that the “finite age of galaxies” would do little to solve the problem in a universe that continually made galaxies *ad infinitum*.

¹⁰⁵² *The Milky Way Galaxy and Statistical Cosmology: 1890-1924*, Erich Robert Paul, Cambridge University Press, 1993.

Einstein's Fudge Factor: The Cosmological Constant

During this time, of course, [Einstein's](#) vision of the universe held sway. Without repeating what we have already discovered about his bizarre universe, suffice it to say that it had its own set of paradoxes. Einstein's original formula kept the universe from collapsing (with a little help from the infamous fudge factor called the "cosmological constant"), but this solution was unstable, since the slightest deviation in the constant would result in an expansion of the universe, which in turn would increase the repulsive force and decrease gravity, and thus increase the expansion exponentially. Conversely, the slightest contraction would result in a premature collapse of the universe. Interestingly enough, Nobel laureate Robert Laughlin explains the problems in terms of our old friend, ether:

The closet of general relativity contains a horrible skeleton known as the cosmological constant. This is a correction to the Einstein field equations compatible with relativity and having the physical meaning of a uniform mass density of relativistic ether. Einstein originally set this constant to zero on the grounds that no such effect seemed to exist. The vacuum, as far as anyone knew, was really empty. He then gave it a small nonzero value in response to cosmological observations that seemed to indicate the opposite, and then later removed it again as the observations improved.¹⁰⁵³

Here we see that the "cosmological constant" was not merely some innocent mathematical figure. In short, Einstein was trapped like the proverbial rat in a corner. If he kept the cosmological constant at zero, his universe would be unstable. If he gave it a non zero value, he would have to admit the existence of ether – the very substance that was initially denied by his Special Theory of Relativity. Thanks to Laughlin's analysis, the average reader has been alerted to the connection. Perhaps this is the reason that in 1916, at just the time he was developing his General Theory of Relativity, Einstein suddenly had a new affection for ether possessing "physical properties." Laughlin reveals the inherent problems such theories will face:

The view of space-time as a nonsubstance with substance-like properties is neither logical nor consistent. It is instead an ideology that grew out of old battles over the validity of relativity. At its core is the belief that the symmetry of relativity is different from all other symmetries in being absolute. It cannot be violated for any reason at any length

¹⁰⁵³ Robert B. Laughlin, *A Different Universe*, p. 123.

scale, no matter how small....This belief may be correct, but it is an enormous speculative leap.¹⁰⁵⁴

This is certainly the irony of ironies. In order to exist, Relativity must function as an oxymoron – it must be absolute! This is the inevitable consequence of a theory that is erroneous from the start. Laughlin tries his best to save Relativity from its self-destruction, but as we will see, he can only appeal to mystery and ignorance as his cudgel:

Despite its having become embedded in the discipline [of Relativity], the idea of absolute symmetry makes no sense. Symmetries are caused *by* things, not the cause *of* things. If relativity is *always* true, then there has to be an underlying reason. Attempts to evade this problem inevitably result in contradictions. Thus if we try to write down relativistic equations describing the spectroscopy of the vacuum, we discover that the equations are mathematical nonsense unless either relativity or gauge invariance, an equally important symmetry, is postulated to fail at extremely short distances. No workable fix to this problem has ever been discovered. String theory, originally invented for this purpose, has not succeeded. In addition to its legendary appetite for higher dimensions, it also has problems at short length scales, albeit more subtle ones, and has never been shown to evolve into the standard model at long length scales, as required for compatibility with experiment.¹⁰⁵⁵

Laughlin then enlightens us to a further anomaly and its accompanying coverup:

Thus the innocent observation that the vacuum of space is empty is not innocent at all, but is instead compelling evidence that light and gravity are linked and probably both collective in nature. Real light, like real quantum-mechanical sound, differs from its idealized Newtonian counterpart in containing energy even when it is stone cold. According to the principle of relativity, this energy should have generated mass, and this, in turn, should have generated gravity. We have no idea why it does not, so we deal with the problem the way a government might, namely by simply declaring empty space not to gravitate.¹⁰⁵⁶

¹⁰⁵⁴ Robert B. Laughlin, *A Different Universe*, pp. 123-124.

¹⁰⁵⁵ Robert B. Laughlin, *A Different Universe*, p. 124-125.

¹⁰⁵⁶ Robert B. Laughlin, *A Different Universe*, p. 125. Laughlin adds: “The desire to explain away the gravity paradox microscopically is also the motivation for the invention of supersymmetry, a mathematical construction that assigns a special complementary partner to every known elementary particle. Were a superpartner ever

As we can see, physicists were discovering that the mathematics that allowed them to toy with whatever universe their minds imagined was the same mathematics that made uncompromising demands they simply could not satisfy. As Edwin Hubble stated it:

Such a universe, if it contains matter, will be unstable. At best it could be in unstable equilibrium, like a ball balanced on a point. The slightest disturbance would upset the balance – and internal disturbances evidently must occur. The universe would then revert to its natural state of either contraction or expansion....At this point the cosmologist seizes upon the observed red-shifts, interprets them as velocity-shifts, and presents them as viable evidence that the actual universe is now expanding, and expanding rapidly.¹⁰⁵⁷

In the 1920s Willem de Sitter and [Alexander Friedmann](#) attempted to find a solution to Einstein's problem, but after they reworked his equations, cosmology didn't know whether it was coming or going, literally and figuratively. De Sitter's modifications had it expanding, while Friedmann's had it contracting, and there was an infinity of possible outcomes between these two extremes depending on how one played with the numbers.

Last but not least, General Relativity, as every Relativist must admit, invariably leads back to a "singularity." There is no escape from this conclusion, mathematically speaking. "Singularity" is the word modern cosmologists employ in order to cover up the fact that they have not the foggiest notion what happens when, according to the logical conclusions of Einstein's theory, all the matter and energy of the universe is sucked back up into the proverbial abyss. Whither it goes, or from whence it came, no one seems to know. Except for a few bold scientific entrepreneurs who don't mind running the risk of appearing mentally unbalanced by suggesting that "singularities" come from "other universes and dimensions," modern science is mute, and painfully so, not to mention the fact that these "other universes" would have the same problem of collapsing in on themselves as our universe.

The lesson to be learned here is that it is extremely dangerous to play with infinity. Anything that is posited as infinite outside of God always leads to absurdities. Physicists and mathematicians have become painfully aware of this intractable problem. The reason we hear talk of "parallel universes" and "alternate histories" from Hollywood's science fiction dramas is that these ideas have already been bandied about in scientific circles as the solutions to the perplexing problems in modern

discovered in nature, the hope for a reductionist explanation for the emptiness of space might be rekindled, but this has not happened, at least not yet" (*ibid*).

¹⁰⁵⁷ *The Observational Approach to Cosmology*, pp. 54-55.

cosmology. Charles Seife, for example, has reasoned that if two premises are accepted: (a) infinite space, and (b) the second law of thermodynamics, then when the second law is applied to blackholes, it leads to a “holographic bound,” that is, any portion of energy and matter enclosed in a finite sphere can be arranged in only a finite number of ways. Accordingly, if the universe is infinite, it means there must be an infinite number of ways to arrange energy and matter that are different than what appears in our little universe. This would inevitably lead to an infinite assortment of universes, with the haunting possibility that a whole host of them are presently mirroring your reading of this book. These imaginative solutions are inevitably created when men mistake the universe for their god.¹⁰⁵⁸

¹⁰⁵⁸ “Physics in the Twilight Zone,” *Science*, 305:464, 2004.

Edwin Hubble and Modern Cosmology's Wax Nose

Undaunted, the theorists marched onward. As we noted earlier, the main impetus for the expanding universe theory was Edwin Hubble, although the idea actually originated with Willem de Sitter. Hubble based his theory of expansion on the redshift of starlight. As we have cited earlier, although Hubble admitted to other viable interpretations of redshift, nevertheless, the interpretation the science establishment connects to Hubble is that redshift is caused by the stretching of the starlight's wavelength, a stretching that is said to be the result of the star's enormous recession speed away from the Earth. The faster the recession, the more the wavelength would be stretched, and thus, the larger the redshift and the further away the star was said to be. The calculation of its recession speed became known as Hubble's Law.

To fit with the data he observed in 1929, Hubble figured that his "H" constant, which was the proportion between the speed of the galaxy compared to its distance away from us, would have to be 100 kilometers per second per megaparsec.¹⁰⁵⁹ Thus, if a galaxy was said to be 10 megaparsecs away from us, Hubble's Law held that it must recede with a velocity of 1000 kilometers per second. If the galaxy were a gigaparsec from us (which is 1000 megaparsecs), it must recede with a velocity of 100,000 kilometers per second.

Why was Hubble's Law so important to modern cosmologists? With this law, one could calculate the rate of expansion, and once one knew the rate, one could then determine how long the expansion had been taking place and, therefore, determine when the universe began. If one could imagine the expansion being reversed until the universe went back to its original form, the Hubble Law could retroactively calculate the age of the universe. If scientists could make the age long enough, then there would be sufficient room to fit in both cosmic and biological evolution. Indeed, the stakes were certainly high.

The circumstances surrounding Hubble's interpretation of the redshift are intriguing. Hubble worked with [Milton Humason](#), but only Hubble's name is associated with the redshift/expansion theory. The primary reason is that Humason was very reluctant to provide evidence for an expanding universe. The scientific community, based on Einstein's reworked mathematical formulas (courtesy of de Sitter and Friedmann), had already decided that the universe was expanding, but they were missing observational evidence. Consequently, they were

¹⁰⁵⁹ A "megaparsec" equals 3.3×10^6 light years. A "light year" is the distance light travels in a year, at 300,000 kilometers per second, which equals 3×10^{19} kilometers. Edwin Hubble, "A Relation Between Distance and Radial Velocity Among Extra-Galactic Nebulae," *Proceedings of the National Academy of Science*, 15, 1929, pp. 168-173. Edwin Hubble and Milton Humason, "The Velocity-Distance Relation Among Extra-Galactic Nebulae," *Astrophysical Journal*, 74, 1931.

more than ready to interpret the redshift as a Doppler phenomenon wherein galaxies are understood to be moving away at great speeds from the observer.¹⁰⁶⁰ This is in the face of the fact that there is no proof for a connection between receding galaxies and redshift, or that galaxies are receding at all, or that redshift is to be interpreted as a Doppler shift. In a paper published in 1931 Humason wrote:

It is not at all certain that the large redshifts observed in the spectra are to be interpreted as a Doppler effect but, for convenience, they are interpreted in terms of velocity and referred to as apparent velocities.¹⁰⁶¹

To refer to them as only “apparent” velocities means that Humason was not committing himself to the Friedmann-Lemaître-Einstein-de Sitter hypothesis. Hubble, of course, knew of Humason’s doubts and makes reference to them: “But later, after the ‘velocity-distance relation’ had been formulated, and Humason’s observations of faint nebulae began to accumulate, the earlier, complete certainty of the interpretation began to fade.”¹⁰⁶² We might say that Humason paid a dear

¹⁰⁶⁰ A Doppler shift, as it is known in sound mechanics, is the expansion of sound’s wavelength as the source of the sound recedes from you (or contraction as the source approaches you). We hear a rapid change in pitch, for example, when a speeding train blowing its whistle either approaches us or recedes from us. Many scientists today claim that the same thing happens to light when it travels, that is, those who believe light is a wave say that the wave expands as the source of light recedes from the observer. The principle of the lengthening or shortening of wavelength was first proposed by Johann Christian Doppler in 1842 but resisted by the science community for two decades. His findings were confined to sound waves. His theory was confirmed by the Dutch scientist C. H. D. Buijs-Ballot in 1845. In 1860 Ernst Mach proposed the Doppler effect was true for light waves, which was tested by W. Huggins in 1868. It wasn’t until 1901 that Russian scientist and editor of the *Astrophysical Journal*, Aristarkh Belopolsky, found the same effect in light waves, which was confirmed by J. Stark in 1905 and Quirino Majorana in 1918. One theory posits that redshift is caused by light’s travel through an electron-positron net pervading all space (M. Simhony, *Invitation to the Natural Physics of Matter, Space, Radiation*, Singapore, New Jersey, World Scientific Publishing, 1994, p. 252; and John Kierein, “Implications of the Compton Effect Interpretation of the Redshift,” *IEEE Trans. Plasma Science* 18, 61 (1990), et al.). In any case, it should be noted that the “Hubble Constant” has not been very constant. In 1926 it had a value of 500 km/sec/megaparsec. With several intermittent decreases, it now stands at 50.3 km/sec/megaparsec (Michael Rowan-Robinson, “Extragalactic Distance Scale,” *Nature*, Dec. 16, 1976, vol. 264, p. 603).

¹⁰⁶¹ “Velocity-Distance Relation Among Extra-Galactic Nebulae,” *Astrophysical Journal*, 74, 1931. We even see Humason’s reluctance positioned in the very title of another article containing the word “apparent”: “The Apparent Radial Velocities of 100 Extra-Galactic Nebulae,” *Astrophysical Journal*, 83, 1936. Humason held his ground even in the face of redshifts he found between 1931-1936 corresponding to 40,000 km/sec.

¹⁰⁶² *The Observational Approach to Cosmology*, p. 29.

price for his non-conformance. Whereas in the early going, the discovery of the redshift/velocity ratio was attributed to “Hubble-Humason,” later, when it was clear that Humason would be the first not to commit, his name was dropped, which is why the public only knows it as “Hubble’s Law.”

Interestingly enough, regardless of what the science establishment now associates exclusively with Edwin Hubble, the fact remains that Hubble never fully committed himself to the now popular interpretation. Hubble was quite aware of what the science community desired, but maintained his distance. He writes:

This explanation interprets redshifts as Doppler effects, that is to say, as velocity-shifts, indicating actual motion of recession. It may be stated with some confidence that redshifts are velocity-shifts or else they represent some hitherto unrecognized principle in physics....Meanwhile, redshifts may be expressed on a scale of velocities as a matter of convenience. They behave as velocity-shifts behave and they are very simply represented on the same familiar scale, regardless of the ultimate interpretation. The term “apparent velocity” may be used in carefully considered statements, and the adjective always implied where it is omitted in general usage.¹⁰⁶³

Obviously, Hubble is making the same conclusion as Humason, that is, he was only committing to the idea of an “apparent velocity” of the galaxies, not an actual velocity. Confirming his meaning is a 1934 lecture in which Hubble cautioned:

The field is new, but it offers rather definite prospects not only of testing the form of the velocity-distance relation beyond the reach of the spectrograph, but even of critically testing the very interpretation of redshifts as due to motion. With this possibility in view, the cautious observer refrains from committing himself to the present interpretation and prefers the colorless term “apparent velocity.”¹⁰⁶⁴

This is especially significant since in Hubble’s day an alternate explanation to redshift had not yet been postulated. Doppler shift was the only game in town, yet Hubble still was not committing himself to it. This skepticism is stated clearly in many works, but especially in the following:

¹⁰⁶³ *The Realm of the Nebulae*, Yale University Press, 1936, pp. 122-123. *The Observational Approach to Cosmology*, p. 22.

¹⁰⁶⁴ 1934 lecture titled: “Redshifts in the Spectra of Nebulae,” *The Halley Lecture*, May 8, 1934, Oxford: Clarendon Press, 1934, p.14.

The investigations were designed to determine whether or not redshifts represent actual recession. In principle, the problem can be solved; a rapidly receding light source appears fainter than a similar but stationary source at the same momentary distance....

For velocities of a few miles or a few hundred miles per second, the dimming factor is negligible. But for the extremely distant nebulae, where the apparent recessions reach tens of thousands of miles per second, the effects are large enough to be readily observed and measured. Hence, if the distances of the nebulae were known quite accurately we could measure their apparent faintness and tell at once whether or not they are receding at the rates indicated by redshifts.

Unfortunately, the problem is not so simple. The only general criterion of great distances is the very apparent faintness of the nebulae which we wish to test. Therefore, the proposed test involves a vicious circle, and the dimming factor merely leads to an error in distance. However, a possible escape from the vicious circle is found in the following procedure. Since the intrinsic luminosities of nebulae are known, their apparent faintness furnishes two scales of distance, depending upon whether we assume the nebulae to be stationary or receding. If, then, we analyze our data, if we map the observable region, using first one scale and then the other, we may find that the wrong scale leads to contradictions or at least to grave difficulties. Such attempts have been made and one scale does lead to trouble. It is the scale which includes the dimming factors of recession, which assumes that the universe is expanding.¹⁰⁶⁵

As we have noted in our earlier discussion of Hubble, he then came to the place where he knew (considering what he actually saw in his telescope) that there were only two options left to him. He writes:

Thus the use of dimming corrections leads to a particular kind of universe, but one which most students are likely to reject as highly improbable. Furthermore, the strange features of this universe are merely the dimming corrections expressed in different terms. Omit the dimming factors, and the oddities vanish. We are left with the simple, even familiar concept of a sensibly infinite universe. All the difficulties are transferred to the interpretation of redshifts which cannot then be the familiar velocity shifts...Meanwhile, on the basis of the evidence now available, apparent discrepancies between theory and observation must be recognized. A choice is presented, as

¹⁰⁶⁵ "The Interpretation of the Redshifts," pp. 108-109, emphasis added.

once before in the days of Copernicus, between a strangely small, finite universe and a sensibly infinite universe plus a new principle of nature.¹⁰⁶⁶

In his 1937 book, *The Observational Approach to Cosmology*, he is even more candid about his doubts regarding the interpretation of redshift, as well as his doubts about the Relativity theory behind it. He was honest enough to admit that there was another viable interpretation, and his book shows that he was deeply troubled by it, for he had no way to disprove it. It was the interpretation which holds that redshift, among other factors, may simply be due to light's energy loss as it collides or interacts with the mediums or debris in space. As Hubble puts the possibility:

...light loses energy in proportion to the distance it travels through space. The law, in this form, sounds quite plausible. Internebular space, we believe, cannot be entirely empty. There must be a gravitational field through which the light-quanta travel for many millions of years before they reach the observer, and there may be some interaction between the quanta and the surrounding medium....Light may lose energy during its journey through space, but if so, we do not yet know how the loss can be explained.¹⁰⁶⁷

The longer light must travel, the more it will interact with the particles of space and the more energy it will lose, and thus the longer will be its shift to the red end of the spectrum.¹⁰⁶⁸ Hubble is so bothered

¹⁰⁶⁶ Edwin Hubble, "The Problem of the Expanding Universe," *American Scientist*, Vol. 30, No. 2, April 1942, pp. 99f; *The Observational Approach to Cosmology*, p. 21. Hubble also states: "for a stationary universe, the law of redshifts is sensibly linear....The results may be stated simply. If the nebulae are stationary, the law of redshifts is sensibly linear; redshifts are a constant multiple of distances. In other words, each unit of light path contributes the same amount of redshift" (p. 111). Likewise, in a paper Hubble wrote with Richard Tolman in 1935, he concludes that the observational information is "not yet sufficient to permit a decision between recessional or other causes for the redshift" (Edwin Hubble and Richard Tolman, "Two Methods of Investigating the Nature of the Nebular Redshift," *Astrophysical Journal*, 82:302-37, 1935). Of the "two methods," of course, one is that redshift does not represent velocity.

¹⁰⁶⁷ *The Observational Approach to Cosmology*, p. 30.

¹⁰⁶⁸ Fritz Zwicky was the first to propose the theory of "tired" light ("Redshift of Spectral Lines," *Proceedings of the National Academy of Sciences*, 1929, v. 15, pp. 773-779), but this was merely the default position for the fact that "Hubble has shown that the observational data which he has obtained do not agree satisfactorily with the homogeneous relativistic cosmological models [viz., the Big Bang theory]" (Guy Omer, "A Nonhomogeneous Cosmological Model," 1949, p. 164). Among the many advocates of the "tired" light theory is the Ukrainian team of N. A. Zhuck, V. V. Moroz, A. A. Varaksin who, rejecting Big Bang cosmology due to the distribution and nature of the 23,760 quasars they examined, are forced to conclude that "the Cosmic Microwave Background Radiation can be either the remainder of the high temperature explosion of

by this possibility that he feels compelled to mention it about a dozen times throughout the book.¹⁰⁶⁹

the super-dense substance or the total radiation of all stars of the stationary universe with the said dissipation of the energy of light.” (“Quasars and the Large Scale Structure of the Universe,” N. A. Zhuck, V. V. Moroz, A. A. Varaksin (*Spacetime and Substance, International Physical Journal*, Ukraine, Vol. 2, No. 5 (10) 2001, p. 193, emphasis added); and N. A. Zhuck in “The Microwave Background Radiation as aggregate radiation of all stars,” XVII International Conference, April 12-14, 2000, Moscow (in Russian); and in *Spacetime and Substance* 1:1, 29-34 (2000). The same conclusion comes from Alex M. Chepick: “The urgency of “tired” light is proved for the stationary universe model and the value of energy loss of a photon on one cycle of light’s wave is constant....The most surprising conclusion...is the value of energy loss of a photon on one cycle of light’s wave is not dependent on a wavelength! Therefore it is a global physical constant....In a 1 meter vacuum a part of the energy loss of light makes $z = 10^{-27}$...because of equal contribution of electrical and magnetic components into the energy of the wave EMF, and that during one cycle there are 4 power transmissions between the electrical and magnetic fields, probably it is necessary to consider energy loss for each such transformation at $\epsilon/4$.” The writers also conclude: “The constancy of this loss suggests [the] existence of stable particles with approximately 10^{-69} kg [i.e., mass of the photon] (“The Calculation of the Indispensable Accuracy of the Measuring of an EM’s Wave Energy,” *Spacetime and Substance*, Vol. 3, 2002, No. 3, 13, p. 111). See also Goldhaber and Nieto “New Geomagnetic Limit on the Mass of the Photon,” *Physical Review Letters* 21:8, 1968, p. 567, which establishes a limit of 2.3×10^{-15} ev. Lakes, “Experimental limits on the Photon Mass and Cosmic Magnetic Vector Potential,” *Physical Review Letters* 80:9, 1998, p. 1826. In 1981, David A. Hanes address the “tired light” issue in the article “Is the Universe Expanding?” (*Nature* 289:745). Other scientists who proposed the “tired light” theory were Max Born and Erwin Finlay-Freundlich but they never developed the theory. Halton Arp holds “tired light” is discounted by the fact that no increase in redshift has been seen from light traveling through dense galactic material; that quasars close together can have vastly different redshifts; that younger quasars have higher redshift; the Butcher-Oemler effect of galaxies of moderate redshift having blue and ultraviolet light; high redshift quasars in the middle of low redshift galaxies (*The Einstein Cross – G2237+ 0305*). Arp postulates that redshift is intrinsic to the object, and since each object is different because it is “created” at a different time, varying redshifts will be produced (*Seeing Red*, pp. 97, 108, 159, 166, 173, 195).

¹⁰⁶⁹ *The Observational Approach to Cosmology*, Oxford, Clarendon Press, 1937, Preface: “the phenomena of red-shifts whose significance is still uncertain”; p. 21: “the law of redshifts...but the uncertainties were considerable”; p. 26: “...red-shifts as velocity-shifts...seems to imply a strange and dubious universe, very young and very small...seems to imply that red-shifts are not primarily velocity-shifts...the observer is inclined to keep an open mind...”; p. 31: “Red-shifts are produced either in the nebulae, where the light originates, or in the intervening space through which the light travels....At present, however, the direct investigation ends in a vicious circle, and the persistent observer is forced to consider a possible indirect attack on the problem”; p. 39: “There seems to be no *a priori* necessity for a linear law of expansion, a strict proportionality between red-shifts and distance”; p. 43: “Thus, the familiar interpretation of red-shifts as velocity-shifts leads to strange and dubious conclusions; while the unknown, alternative interpretation leads to conclusions that seem plausible and even familiar”; p. 44: “The fundamental question is the interpretation of red-shifts”; p. 55: “At this point the cosmologist seizes upon the observed red-shifts, interprets them as velocity-shifts...” Radio astronomer, Grote Reber (d. 2002), who built the first radio telescope in 1937, points out many of these very pages in Hubble’s book to

Throughout the book we see Hubble struggling to make the data conform to the theories of the day. On the one hand, he knows that if he interprets redshift as a velocity-indicator, then he winds up with a universe that is too small and too young to accommodate the theory of biological evolution. As he puts it:

A universe that has been expanding in this manner would be so extraordinarily young, the time-interval since the expansion began would be so brief, that suspicions are at once aroused concerning either the interpretation of redshifts as velocity-shifts or the cosmological theory in its present form.¹⁰⁷⁰

But if Hubble interprets redshift as a loss of light's energy, he has a more "plausible" model for redshift but one that produces an "indefinitely large" universe and, most of all, does not allow for the postulates of Special or General Relativity. As he puts it:

On the other hand, if the recession factor is dropped, if redshifts are not primarily velocity-shifts, the picture is simple and plausible. There is no evidence of expansion and no restriction of the time-scale, no trace of spatial curvature, and no limitation of spatial dimensions.¹⁰⁷¹

What a dilemma for science! Hubble's only other alternative had already been discounted – an Earth-centered cosmos that was closed and finite. So what does a good scientist do in such a situation? He preserves the sacrosanct theory of General Relativity as best he can by making convenient *ad hoc* assumptions and creating arbitrary variables that will give it some semblance of respectability. The first assumption needed is that the universe is "homogeneous," that is:

...there must be no favored location in the universe [i.e., no central Earth], no center, no boundary; all must see the universe alike. And, in order to ensure this situation, the cosmologist postulates spatial isotropy and spatial homogeneity....

Once "homogeneity" is assumed (not proven), one needs to get to an "expanding universe," for this will help support the trend in modern

indicate that Hubble had "grave doubts about redshifts being caused by relative motion." As noted previously, Reber is the true discoverer of the Cosmic Background Radiation, not Penzias and Wilson ("Cosmic Static at 144 meters wavelength," *Journal of the Franklin Institute*, vol. 285 (Jan. 1968), pp. 1-12). A biographical note reveals that Reber's mother was Edwin Hubble's seventh-grade teacher.

¹⁰⁷⁰ *The Observational Approach to Cosmology*, p. 46.

¹⁰⁷¹ *The Observational Approach to Cosmology*, p. 63.

cosmology toward the Big Bang theory. But if one introduces expansion into a homogeneous universe, this will cause an imbalance in the “law of distribution” wherein, as Hubble warns his reader:

...the density of the nebular distribution increases outwards, symmetrically in all directions, leaving the observer in a unique position. Such a favoured position, of course, is intolerable; moreover, it represents a discrepancy with the theory, because the theory postulates homogeneity. Therefore, in order to restore homogeneity, and to escape the horror of a unique position, the departures from uniformity, which are introduced by the recession factors, must be compensated by the second term representing effects of spatial curvature. There seems to be no other escape.¹⁰⁷²

In other words, rather than the nebulae thinning out as the distance from their origin increases (as one would expect in an expanding universe), conversely, Hubble’s telescope tells him that the distant nebulae have the same concentration as the nearer nebulae. So now Hubble needs to invent another variable that will compensate for this lack of thinning out. Hubble makes no excuses for the *ad hoc* nature of this seemingly desperate attempt to salvage modern theory. He writes:

To the observer the procedure seems artificial...in testing the relativistic theory, he introduces a new postulate, namely recession of the nebulae, and it leads to discrepancies. Therefore, he adds still another postulate, namely, spatial curvature, in order to compensate the discrepancies introduced by the first.¹⁰⁷³

In other words, geodesic geometry is used to curve the space of the homogeneous universe so that it can bend it to conform with the mathematics of General Relativity. As Hubble puts it:

Theoretical investigators, guided by the assumption of homogeneity, adopt Riemannian geometry which operates in curved space. The curvature cannot be visualized...It is sufficient to say that the nature of the curvature is indicated, and the amount is measured, by the radius of curvature (which projects, as it were, to higher dimensions). The radius in our

¹⁰⁷² *The Observational Approach to Cosmology*, pp. 58-59. Hubble adds: “Observations demonstrate that: $\log_{10} N = 0.6m_c + \text{constant}$. Relativistic cosmology requires that $\log_{10} N = 0.6(m_c - d\lambda/\lambda + C_v) + \text{constant}$, therefore $C_v = d\lambda/\lambda$. The curvature of space is demonstrated and measured by the postulated recession of the nebulae.” N = number of nebulae per square degree; m_c = the limiting faintness expressed as a magnitude; $d\lambda/\lambda$ = the recession factor; C_v is the effect of spatial curvature.

¹⁰⁷³ *The Observational Approach to Cosmology*, p. 59.

universe might be positive, negative or zero, and might be large or small. A positive curvature implies closed space, a universe with a definite, finite volume but with no boundary. A negative curvature implies open space, an infinite universe. The limiting case of zero curvature is ‘flat’ Euclidean space with an infinite radius...and, in all but flat space, the amount of curvature has a wide range of possible values.¹⁰⁷⁴

But, even after admitting that his “theoretical investigators” produce such *ad hoc* solutions, nevertheless, in order to remain with the consensus, Hubble adds his own *ad hoc* touches to round out the picture:

Actually, no curvature can be found which exactly compensates for the apparent departures from uniformity in each of the surveys. Nevertheless, if we admit the presence of rather considerable systematic errors in the observations, it is possible to select a curvature which will more or less restore homogeneity. Hidden errors of the necessary dimensions are by no means impossible in the very delicate investigations near the limits of a great telescope. Therefore the expanding universe can be saved by introducing a sufficient amount of spatial curvature.¹⁰⁷⁵

All in an effort to save the “expanding universe,” Hubble is so desperate that, realizing that even “curvature” cannot solve the problem, he proposes that perhaps there was a error in what he saw with his own eyes through his own telescope. He doesn’t know for certain such error exists, but he depends on it nevertheless. This is quite ironic since Hubble’s book is titled *The Observational Approach to Cosmology*, wherein the operative word is “Observational.” In the end, Hubble’s view is not about what Hubble “observes” but only what his philosophical presuppositions will allow him to believe. In the end Hubble makes a travesty of “observational” cosmology.

As far as modern science is concerned, Hubble remains somewhat of an enigma. Although he dismissed an Earth-centered solution for his “observations,” his book leaves his colleagues with an equivocation that they would rather he not have said: “Two pictures of the universe are sharply drawn...we seem to face, as once before in the days of Copernicus, a choice...” The science establishment has made a concerted effort to ignore this equivocation, however. As they did in order to support Einstein’s Relativity theory when, in 1919, the world’s scientists promoted only one of Eddington’s eclipse photographs (and ignored the rest) to show anyone who would believe them that light bent around the sun in accord with the predictions of General Relativity, so

¹⁰⁷⁴ *The Observational Approach to Cosmology*, pp. 54-55.

¹⁰⁷⁵ *The Observational Approach to Cosmology*, p. 60.

they ignore Hubble's alternate interpretation of redshift and cite only his initial paper of 1929, for it appears to be the only one that indicates redshift as the sole indicator of radial velocity. These unconscionable breeches of protocol are common in the science establishment. In most cases, only the evidence supporting the prevailing view will be published in the journals and popular books.

Allan Sandage, who is known for taking over the work of Hubble and who was dubbed by the *New York Times* as “the grand old man of cosmology,” makes a concerted effort to give the impression that either Hubble made a mistake in doubting that redshift is a velocity indicator, or that he didn't mean what he wrote:

We now come to one of the most remarkable episodes in all of science. Hubble's detailed analysis...is a most fascinating study of how an interpretation, without caution concerning possible systematic errors, led to a conclusion that the systematic redshift effect is probably not due to a true Friedmann-Lemaître expansion, but rather to an unknown, then as now, unidentified principle of nature. Indeed, even in the abstract to this 1936 paper on the *Effects of Redshift on the Distribution of Nebulae*, Hubble concluded: ‘The high density suggests that the expanding models are a forced interpretation of the data.’ His belief that the expansion probably is not real persisted even into his final 1953 paper which was the Darwin lecture of the RAS, given in May of the year he died in September. What were the steps leading to this conclusion that, in today's climate, seems so remarkable?¹⁰⁷⁶

It is “remarkable” to Sandage because he is the heir-apparent to Big Bang cosmology, and it is his job to make sure that Hubble's doubts about the redshift/velocity relationship are covered over. Sandage has made it quite clear that, opposed to Hubble, he is firmly committed to Big Bang expansion theory. In one popular venue Sandage says: “The expansion of the entire universe is the most important single hard scientific fact of cosmology,”¹⁰⁷⁷ but, of course, it is not a “fact” at all, let alone a “hard” one. That Sandage is aware of Hubble's reluctance to interpret redshift as a function of velocity is freely admitted:

Hubble concluded that his observed $\log N(m)$ distribution showed a large departure from Euclidean geometry, provided that the effect of redshifts on the apparent magnitudes was calculated as if the redshifts were due to a real expansion. A different correction is required if no motion exists, the redshifts then being due to an unknown cause. Hubble believed that his

¹⁰⁷⁶ (http://nedwww.ipac.caltech.edu/level5/Sandage2/Sandage2_3.html).

¹⁰⁷⁷ “Cosmology,” *Hammond Barnhart Dictionary of Science*, Barnhart Books, 1986.

count data gave a more reasonable result concerning spatial curvature if the redshift correction was made assuming *no recession*. To the very end of his writings he maintained this position, favoring (or at the very least keeping open) the model where *no true expansion* exists, and therefore that the redshift “represents a hitherto unrecognized principle of nature.” This viewpoint is emphasized (a) in *The Realm of the Nebulae*, (b) in his reply (Hubble 1937a) to the criticisms of the 1936 papers by Eddington and by McVittie, and (c) in his 1937 Rhodes Lectures published as *The Observational Approach to Cosmology* (Hubble 1937b). It also persists in his last published scientific paper which is an account of his Darwin Lecture (Hubble 1953).¹⁰⁷⁸

But Hubble was not only opposed to the “Friedmann-Lemaître expansion,” in the same 1936 paper he points to another target – General Relativity:

...if redshifts are not primarily due to velocity shifts, the observable region loses much of its significance. The velocity-distance relation is linear; the distribution of nebulae [galaxies] is uniform; there is no evidence of expansion, no trace of curvature, no restriction of the time scale.¹⁰⁷⁹

The reader should stop and digest what an amazing statement this is. Without any equivocation, Hubble declares that, if he is correct that the redshift/velocity relationship is mistaken, Einstein’s theory of Relativity is totally erroneous. Space “curvature” and “restriction of the time scale” were Relativity’s basic tenets. Without them, there is no Relativity. No wonder Sandage does his best to silence Hubble’s doubts. Without the relation between redshift and velocity, Einstein has become worse than the medievals he accused of superstition.

All in all, the importance of this cross-section of astrophysical theory cannot be underestimated due to the esteem Hubble enjoys as the world’s greatest astronomer of the twentieth century. As Sandage says of

¹⁰⁷⁸ Allan Sandage, *Journal of the Royal Astronomical Society of Canada*, Vol. 83, No. 6, Dec. 1989.

¹⁰⁷⁹ *Astrophysical Journal* 84, 517 (1936), p. 553; and *The Observational Approach to Cosmology*, p. 63. Hubble continues: “The unexpected and truly remarkable features are introduced by the *additional assumption that redshifts measure recession*. The velocity-distance relation deviates from linearity by the exact amount of the postulated recession. The distribution departs from uniformity by the exact amount of the recession. The departures are compensated by curvature, which is the exact equivalent of the recession. Unless the coincidences are evidence of an underlying necessary relation between the various factors, *they detract materially from the plausibility of the interpretation*, the small scale of the expanding model, both in space and time is a novelty, and as such will require rather decisive evidence for its acceptance” (emphasis added).

Hubble: “His success was remarkable, and his proportionate influence nearly unparalleled in modern astronomy.”¹⁰⁸⁰ But as they did with Humason, so they did with Hubble. If a scientist does not support the *status quo*, they are ostracized or reinterpreted, and that is why hardly anyone in college physics classes knows of Hubble’s alternatives or the grave problems he saw in the redshift/velocity relationship.

Irrespective of his quandary regarding whether redshift is related to velocity, Hubble’s proposed age of the universe gave at least some semblance of a time-scale that would not force science to capitulate to the six-day creation of Genesis. In his 1953 George Darwin lecture he states:

When no recession factors are included, the law will represent approximately a linear relation between redshifts and distance. When recession factors are included, the distance relation is...accelerated expansion...the age of the universe is likely to be between 3000 and 4000 million years, and thus comparable with the age of rock in the crust of the Earth.¹⁰⁸¹

Although it is difficult to know from the syntax whether Hubble was basing the time-span of 3-4 billion years upon the inclusion or elimination of recession factors, nevertheless, he gives us only 3-4 billion years for the “age of the universe.” Note that Hubble did not say “age of the Earth.” This is what is known in cosmology as “Hubble time,” since it was derived directly from Hubble’s Law of Expansion, and it was only one of three dating methods used at that time, the other two being radiometric dating by isotope decay and the composition of stars.

Hubble’s conclusions caused quite a problem. A universe that was expanding for only 3-4 billion years would mean that the Earth, which was understood to come long after the initial expansion, would not be old enough to match the evidence from the burgeoning field of radiometrics that the Earth had to be at least 3-4 billion years old, which would require the universe to be much older. “Hubble time,” of course, was far lower than that allowed by radiometric dating or star composition. In fact, even though Sandage claims that Hubble’s 3-4 billion year time-span is based on “no recession factor” (and, therefore, Hubble’s time-span would be higher if a recession were included), nevertheless admits:

¹⁰⁸⁰ Allan Sandage, *Journal of the Royal Astronomical Society of Canada*, Vol. 83, No. 6, Dec. 1989.

¹⁰⁸¹ “The Law of Redshifts,” George Darwin Lecture, May 1953, *Royal Astronomical Society*, 113, 658. Allan Sandage claims that the sentence “the age of the universe is likely to be between 3000 and 4000 million years” refers to the fact that “no recession factor is included,” but this cannot be proven based on the syntax of Hubble’s paragraph.

There was, of course, the embarrassment that the inverse of the Hubble expansion rate (*i.e.*, the Hubble time) was only two billion years on Hubble's 1930 to 1953 distance scale whereas the Earth was believed to be a bit older than three billion years even in 1936. It was left to the inventors of the steady state cosmology to emphasize this discrepancy of time scales, pointing out that any of the Friedmann models (*sans* cosmological constant) that were used to espouse a 'beginning' could not be true¹⁰⁸²

Guy Omer had already pointed out these difficulties in the late 1940s. He writes:

E. Hubble has shown that the observational data which he has obtained do not agree satisfactorily with the homogeneous relativistic cosmological models...The model has a short time scale. The present age of the model must be less than 1.2×10^9 [1.2 billion] years. This is about one-third the recent estimation of the age of the earth as an independent body, made by A. Holmes. This is probably the most serious difficulty of the homogeneous model. Because of the unrealistic aspects of the homogeneous relativistic model, Hubble proposed an alternate model which would be essentially static and homogeneous and in which the red shift would be produced by some unknown but nonrecessional mechanism.¹⁰⁸³

¹⁰⁸² Allan Sandage, *Journal of the Royal Astronomical Society of Canada*, Vol. 83, No. 6, Dec. 1989.

¹⁰⁸³ Guy C. Omer, Jr., "A Nonhomogeneous Cosmological Model," *Journal of the American Astronomical Society*, 109, 1949, pp. 164-165. Omer continues: "There have been several suggestions of possible mechanisms which would produce red shifts without having actual physical recession. F. Zwicky [*Proceedings of the National Academy of Sciences*, 15, 773, 1929] has proposed that photons may lose energy with time, perhaps by a gravitational interaction with the matter along their trajectories. R. C. Tolman [*Relativity, Thermodynamics, and Cosmology*, Oxford, Clarendon Press, 1934, pp. 285ff], however, has shown that 'gravitational drag' cannot account for the observed red shift if the relativity theory is valid. If the extragalactic red shift were produced by 'gravitational drag,' we should expect to measure red shifts within our own local group which would be greater than those indicated by Hubble's linear law, since the mean density of matter within the local group is greater than the average density of matter for the entire universe. If the photon's loss of energy were dependent upon time alone, we should expect to measure red shifts within our own local group which would be exactly equal to those predicted by Hubble's linear law." At this point, in order to save face for the theory, Hubble was ready to "suggest that the law of red shifts does not operate within the local group" (Omer, p. 166). In any case, the same difficulty arose: squaring this theory with the theory of evolution. Omer continues: "P. A. M. Dirac has proposed that the physical 'constants' are not constant with time but may vary in a systematic manner. This proposal would account for an observed red shift without any actual physical recession....E. Teller [*Physical Review*, 73, 801, 1948] has recently criticized Dirac's proposal, since there is considerable geological and biological evidence that the surface temperature of the earth has been reasonably

Since it was necessary to have the age of the Earth coincide with radiometrics, and since Hubble's law only provided half the needed age, as a result various theories were proposed to bridge the gap so as to add the needed years to evolutionary theory. Hubble had already come across some ingenious solutions from his colleagues. He writes:

Theories may be revised, new information may alter the complexion of things, but meanwhile we face a rather serious dilemma. Some there are who stoutly maintain that the Earth may well be older than the expansion of the universe. Others suggest that in those crowded, jostling yesterdays, the rhythm of events was faster than the rhythm of the spacious universe today; evolution then proceeded apace, and, into the faint surviving traces, we now misread the evidence of a great antiquity.¹⁰⁸⁴

But Hubble admitted that such excuses "...sound like special pleading, like forced solutions of the difficulty."¹⁰⁸⁵

constant for the last 5×10^8 years. With Dirac's hypothesis and the additional assumption that the masses of the earth and the sun have remained constant, Teller finds that the surface temperature of the earth would have been near the boiling-point for water within this time interval" (Omer, p. 166).

¹⁰⁸⁴ *The Observational Approach to Cosmology*, p. 44.

¹⁰⁸⁵ *The Observational Approach to Cosmology*, p. 44.

The Proposed Solutions of Lemaître, Eddington, et al.

[Fr. Georges Lemaître](#) had quite a convenient explanation for Hubble's problem. In his model, the universe expands, but it reaches a point where the expansion slows down, at least long enough to allow the Earth to age sufficiently to match radiometric dating.¹⁰⁸⁶ What causes this "slow down" is anyone's guess, for Lemaître gives his readers few clues.

Next in line was Arthur Eddington. As noted previously, he is a good example of how ideology rules science. Not liking Lemaître's concept of at least some beginning to the universe, Eddington writes: "Philosophically, the notion of a beginning of the present order of Nature is repugnant to me....I should like to find a genuine loophole."¹⁰⁸⁷ Hence, as he did when he turned the inconclusive eclipse photographs into a conclusive support for General Relativity, Eddington shows that he is not above twisting the evidence to support his own philosophy. Nothing less than an infinite universe was on Eddington's agenda. By now we know the motivations for preferring an infinite universe – it needs no Creator, and thus there is no God to whom man must answer.

Lemaître then continued the see-saw. Trying to pacify Eddington, Lemaître suggested that the universe evolved from a single, primeval atom. This would, he hoped, "be far enough from the present order of Nature to be not at all repugnant." He writes:

We could conceive the beginning of the universe in the form of a unique atom, the atomic weight of which is the total mass of the universe. This highly unstable atom would divide in smaller and smaller atoms by a kind of super-radioactive process.¹⁰⁸⁸

Lemaître's view was eventually dubbed the "cosmic egg" theory, and eventually led to the concept of the "Big Bang," the popular term originally coined in jest by Sir Fred Hoyle. In essence, while Lemaître roosted on the "cosmic egg," Eddington advocated a "cosmic chicken," a universe that, as he desired, "allows evolution an infinite time to get

¹⁰⁸⁶ Georges Lemaître, "A Homogeneous Universe of Constant Mass and Increasing Radius Accounting for the Radial Velocity of Extra-Galactic Nebulae," *Royal Astronomical Society*, 91, 1931, pp. 483ff, translated from the original French paper published in 1927.

¹⁰⁸⁷ Arthur Eddington, "The End of the World: from the Standpoint of Mathematical Physics," *Nature*, 127, 1931, p. 450.

¹⁰⁸⁸ Georges Lemaître, *The Primeval Atom: An Essay on Cosmogony*, trans. Betty and Serge Korff, New York: D. Van Nostrand, 1950, pp. 99-100.

started.”¹⁰⁸⁹ Hence, the question of which came first: the “cosmic egg” or the “cosmic chicken”(?) would dictate the course of all the various theories of cosmology proposed in the twentieth century.

Lemaître, being a Catholic priest and thus committed to at least some semblance of exegetical logic, had his own problems, since the only “cosmic egg” to which Genesis gives any credence is the “Earth, without form and void” on the first day of creation. So if the Earth is the first thing in existence, then there cannot be a Big Bang. Consequently, any cosmological theory positing that the universe began with something other than the Earth has simply misinterpreted, ignored, or rejected, the words of inspired Scripture.

Unfortunately, many Catholic priests were doing just that in the period Lemaître was writing. In the 1940s Fr. Pierre Tielhard de Chardin, a paleontologist, was adapting Lemaître’s long-ages to his own theory advocating the biological evolution of man.¹⁰⁹⁰ Prior to Tielhard was Fr. George Mivart in his 1871 book *On the Genesis of Species*,¹⁰⁹¹ which was followed by Fr. Ernest Messenger in his 1932 book, *Evolution and*

¹⁰⁸⁹ Georges Lemaître, “On the Instability of Einstein’s Spherical World,” p. 672. See also “The Instability of the Einstein Universe,” W. B. Bonnor, *Royal Astronomical Society*, December 9, 1954.

¹⁰⁹⁰ *The Phenomenon of Man*, Harper & Row, 1975, revised English translation by Benjamin Wall. The Church refused to allow de Chardin to publish his books. In short, de Chardin ascribes all present turmoil in the world to the crisis or “phenomenon” which comes before every new mutation. He sees God as the Primal Impulse manifested in matter. From the Big Bang explosion that he believed occurred 20 billion years ago, de Chardin asserted that the “primal Creator” pressed into all matter, generating an ever greater spiritual consciousness, the final destiny being the “Omega Point” in which the divine impulse is perfectly manifested in all humanity. The knowledge needed to arrive at the Omega Point is preserved for future generations in the “noosphere,” a collection of all the progressive thoughts of mankind. He writes: “the noosphere...Because it contains and engenders consciousness, space-time is necessarily of a convergent nature. Accordingly its enormous layers, followed in the right direction, must somewhere ahead become involuted to a point which we might call Omega, which fuses and consumes them integrally in itself...” (p. 259). Tielhard de Chardin became quite infamous in science circles when his forgery of Piltdown Man was exposed forty years after he introduced it as a missing-link.

¹⁰⁹¹ *On the Genesis of Species*, New York: D. Appleton and Company, 1871. Mivart was a creationist early on, and later, while teaching at the University of Louvain, he became a theistic evolutionist. Mivart’s thesis was that the statement in Genesis 1, “according to their kinds” referred to “species” in biological science. Theistic evolutionists were not accepted by the secular world, however. T. H. Huxley, for example, refuted Mivart’s attempt at coinciding Genesis and evolution, as well as contesting Mivart’s view that various Church Fathers and Scholastics, notably Francisco Suarez, could be interpreted as teaching the concept of evolution wherein one species gives rise to another. Huxley’s motivation was to sever religion completely from science. At one point he stated that religion “could never lay its hands, could never touch, even with the tip of its finger, that dream with which our little life is rounded” (*Einstein: The Life and Times*, p. 503).

*Theology: The Problem of Man's Origin.*¹⁰⁹² Suffice it to say that most of Catholic academia has capitulated to the Copernican/Evolutionary/Relativity model of cosmology and have thereby disowned their traditional heritage.

The theories continued. Nothing short of a half-dozen other theories were proposed in the 1930s through 1950s. Prompted by Sir James Jeans' 1929 theory – a theory which held that, due to the time needed to break up star clusters, the universe was not billions, but trillions of years old, and that the universe is continually creating new matter which it obtains from other dimensions – the idea of an infinite universe was revived.¹⁰⁹³ A universe with no beginning and no end would, in other words, produce a steady number of stars with unending births and evolutions. As one can surmise quite quickly, the goal of modern cosmology was to get to the point of making the Creator's presence superfluous, since matter was deemed quite capable of generating itself. Since distant galaxies appeared to be the same form, size and distribution as nearer galaxies, and yet were said to be part of an expanding universe, the only solution left was to claim that matter was filling the void by steadily and perpetually creating itself. As we noted earlier, this idea was eventually popularized by [Hermann Bondi](#) in 1960, and further promoted by [Stephen Hawking](#). Both of these men have serious ideological motivations for their theories. Hawking, as we recall, made no apologies for allowing his personal philosophy to dictate his cosmological conclusions. He writes:

However we are not able to make cosmological models without some admixture of ideology. In the earliest cosmologies, man placed himself in a commanding position at the center of the universe. Since the time of Copernicus we have been steadily demoted to a medium sized planet going round a medium sized star on the outer edge of a fairly average galaxy, which is itself simply one of a local group of galaxies. Indeed we are now so democratic that we would not claim that our position in space is specially distinguished in any way. We shall, following Bondi (1960), call this assumption the Copernican principle.¹⁰⁹⁴

¹⁰⁹² *Evolution and Theology: The Problem of Man's Origin*, New York: Macmillan and Company, 1932. Messenger also translated Canon Henri de Dorlodot's book into English in 1922, under the title *Darwinism and Catholic Thought*. Also in this genre is Enrico Zoffoli's book *Cristianesimo: corso di teologia cattolica* (Udine: Edizioni Segno, 1994).

¹⁰⁹³ Jeans writes: "...matter can be continuously in the process of creation...stars and other astronomical bodies as passing in an endless steady stream from creation to extinction...with a new generation always ready to step into the place vacated by the old" (James Jeans, *Astronomy and Cosmogony*, 2nd ed, Cambridge University Press, 1929, p. 421).

¹⁰⁹⁴ Stephen Hawking and G. F. R. Ellis, *The Large Scale Structure of Space-Time*, Cambridge University Press, Cambridge, 1973, p. 134.

Here we see the intimate connection between the theories of Bondi and Hawking, both for the sole purpose of perpetuating the “Copernican principle.” Bondi made it clear that philosophical motivations were the impetus of his cosmological inventions in the following statement:

...the problem of the origin of the universe, that is, the problem of creation, is brought within the scope of physical inquiry and is examined in detail instead of, as in other theories, being handed over to metaphysics.¹⁰⁹⁵

¹⁰⁹⁵ Hermann Bondi, *Cosmology*, 2nd ed., Cambridge University Press, 1960, p. 140. Bondi had been advocating this view since 1948.

The Galaxy Formation Problem

Accordingly, modern astrophysics continues to keep its anomalies a well-kept secret. It simply cannot explain the formation of galaxies. In 1975, James Binney informed us:

The real problems of galaxy formation remain very much unsolved. The greatest difficulty is that we still have no idea what induced the formation of the first bound objects in an expanding universe.”¹⁰⁹⁶

Ivan King stated that the problem was a “flagrant scandal that is rarely mentioned in public.”¹⁰⁹⁷ A recent study by Johns Hopkins University with a press release by Karl Glazebrook on July 7, 2004 stated:

It seems that an unexpectedly large fraction of stars in big galaxies were already in place early in the universe’s formation, and that challenges what we’ve believed. We thought massive galaxies came much later. . . . This was the most comprehensive survey every done covering the bulk of the galaxies that represent conditions in the early universe. We expected to find basically zero massive galaxies beyond about 9 billion years ago, because theoretical models predict that massive galaxies form last. Instead, we found highly developed galaxies that just shouldn’t have been there, but are.”¹⁰⁹⁸

¹⁰⁹⁶ *Nature*, 255:275-276, 1975; See also: J. Binney, 1981b, in *The Structure and Evolution of Normal Galaxies*, ed. S. M. Fall and D. Lynden-Bell, Cambridge: Cambridge Univ. Press. J. Binney, 1982b, *Annual Review of Astronomy and Astrophysics*, 20, 399.

¹⁰⁹⁷ *The Evolution of Galaxies and Stellar Populations*, ed. B. M. Tinsley and R. B. Larson, New Haven: Yale University Observatory, 1977. Ivan R. King was professor of astronomy at the University of California, Berkeley.

¹⁰⁹⁸ Alan M. MacRobert confirms the dilemma: “Astronomers thought they had a nice, clear picture of how galaxies formed billions of years ago – but now the picture is suddenly turning muddy. A team studying the faintest galaxies ever to have their spectra taken is finding far too many big, mature galaxies similar to our Milky Way much too early in cosmic history. ‘Theorists are not yet at the point of panic, but they’re getting there’” (*Sky and Telescope*, “Old Galaxies in the Young Universe,” January 6, 2004). The BBC, in “Hubble’s Deepest Shot is a Puzzle,” reports of the 800 exposures in a patch of Hubble’s Ultra Deep Field that there are far fewer stars existing than expected, stating that this “brings into question current ideas on cosmic evolution.” Leader of the survey, Dr. Andrew Bunker, stated: “Another possibility is that physics was very different in the early Universe; our understanding of the recipe stars obey *when they form* is flawed” (BBC News, Sept. 23, 2004), emphasis added.

Another famous astronomer, [Sir Fred Hoyle](#), was also not shy divulging the philosophical basis for his cosmological views. In his partiality to the “steady state” theory, he revealed,

[It] seemed attractive, especially when taken in conjunction with aesthetic objections to the creation of the universe in the remote past. For it seems against the spirit of scientific inquiry to regard observable effects as arising from “causes unknown to science,” and this in principle is what creation-in-the-past implies.¹⁰⁹⁹

By this time the reader should be able to see very clearly the driving force behind the inventions of these men. Their deep and uncompromising desire to safeguard Copernican cosmology could not be stated more forcefully. Apparently, they will say or do whatever it takes to remove Earth from the center of the universe. Of course, those of us on the other side know why: deep down, Hawking, Bondi, Hoyle, *et al.*, know that the Creator exists, but they choose to suppress that knowledge, and thus they concoct whatever cosmological theories they can in order to convince themselves, even if only temporarily, that not only does He not exist, but that He is not even needed.

The self-creation of matter has been the underlying agenda of almost all of modern cosmology, but, of course, it is all a lie, and men are continually deceived by it. The reason the galaxies are fully formed and distributed non-randomly is simply because God created them all at the same time and placed them in their special positions in the universe. In reality, the most plausible explanation left to the scientist is that the galaxies were instantaneously formed whole and fully functional, for that is what the scientific evidence shows to us. But that solution, of course, is “unthinkable” to modern scientists. Accordingly, Isaiah can say:

Lift up your eyes on high and see who has created these *stars*,
The One who leads forth their host by number, He calls them
all by name; Because of the greatness of His might and the
strength of *His* power, not one of them is missing.¹¹⁰⁰

Simple physical laws preclude galaxies from existing for billions of years, since it is well documented that in spiral galaxies, for example,

¹⁰⁹⁹ Fred Hoyle, “A New Model for the Expanding Universe,” *Royal Astronomical Society*, 108, 1948, p. 372. In his book, *The Nature of the Universe*, Oxford University Press, 1952, Hoyle admits: “there is a good deal of cosmology in the Bible...it is a remarkable conception,” but concludes that Christianity is a “desperate attempt to find an escape from the truly dreadful situation in which we find ourselves...an eternity of frustration” (pp. 109-111).

¹¹⁰⁰ Isaiah 40:26. Also, Psalm 147:4 [146:4]: “He counts the number of the stars; He gives names to all of them.”

the dense cores rotate faster than the outer arms. As such, the arms would either become very twisted or eventually wrap around and fuse into the core in a very short time.¹¹⁰¹ That the galaxies are presently in such pristine shape demonstrates they are indeed very young. Similarly, individual stars provide us with the same evidence. No one has ever found evidence of a star forming. Only exploding stars have been discovered. The same is true of stellar novae. They occur every 20-30 years when a star dies and becomes a super nova. However, there are fewer than 300 super nova rings (which are the remnants of the explosions) in the entire observable universe. If the universe is billions of years old, there should be literally millions of such rings. This evidence indicates that the stars were made fully formed in recent history and intermittently deteriorate by natural causes. As astronomer [Gerardus Bouw](#) notes:

Evolutionary models have never been successful in accounting for the formation of a single star, let alone a whole galaxy or even a cluster of galaxies (Jones, B. J. T., 1976, *Review of Modern Physics*, 48:107). Virtually every model in vogue today, which attempts to account for such objects, assumes that they were formed from the collapse of certain density irregularities postulated to be present in the early stages of the Big Bang. Without such an assumption, the physics of collapsing gas clouds would not allow for the formation of objects even remotely resembling the major constituents of the universe. A number of explanations have been proposed to account for such density irregularities, including magnetohydrodynamical “pinch” effects (Fennelly, A. J., 1980, *Physical Review Letters*, 44:955), but the existence of the required cosmic magnetic field is in doubt and the 3-degree Kelvin blackbody radiation reveals no evidence for any significant clumps of matter at the time believed to be about a million years into the evolution of the Big Bang.¹¹⁰²

Additionally, if the galaxies are receding from us at the enormous speeds dictated by the Big Bang, then they should have broken their gravitational bonds long ago, and the farthest galaxies should be seen to have dissipated, but according to the above reports, such is not occurring. Big Bang cosmology attempts to answer this galactic anomaly with the forces of Dark Matter, claiming that the gravity of the latter is holding the former together, and that Dark Energy is propelling the Dark Matter. This, of course, is pure speculation since, with all the powerful telescopes available, no one has seen anything resembling Dark Matter

¹¹⁰¹ *Physics of the Galaxy and Interstellar Matter*, Springer-Verlag, 1987, pp. 352-413. *In the Beginning*, Walt Brown, pp. 23, 30.

¹¹⁰² *The Biblical Astronomer*, vol. 14, no. 110, p. 112.

or Dark Energy, and thus the science community has invented its convenient phantoms for themselves and the gullible public.

Gamow and the Birth of the Big Bang

[George Gamow](#), the precursor to the modern idea of the Big Bang, was also a firm believer in the instantaneous and perpetual creation of matter. As he modeled his theory of the universe to coincide with his work in nuclear physics during the Manhattan Project, Gamow held that just as the atom bomb could create, in a millionth of a second, radioactive elements that were later found in the deserts of midwestern test sites, so too, the elements of the universe could have been created in a super explosion at the beginning of time. Gamow's theory was thunderously applauded by the scientific community, a community that was looking for anything to get them out of the dead ends left to them by de Sitter, Lemaître and Friedmann. Of course, Gamow did not have an explanation for how this super explosion originated, but that didn't really matter for as far as everyone was concerned, in this case the ends justified the means. Reminiscing about a conversation with Einstein, he writes:

I remember that once, walking with him to the institute, I mentioned Pascual Jordan's idea of how a star can be created from nothing, since at the point zero its negative gravitational mass defect is numerically equal to its positive rest mass. Einstein stopped in his tracks, and, since we were crossing a street, several cars had to stop to avoid running us down."¹¹⁰³

Indeed, the whole world has been stopped in its tracks because of the preposterous idea that matter creates itself. Matter has become the god of modern man, powerful enough to bring itself into being, evolve into stars and human beings, and continue on into eternity while watching its creatures die their hapless deaths.¹¹⁰⁴ As [Carl Sagan](#) preached:

¹¹⁰³ George Gamow, *My World Line*, 1970, p. 150.

¹¹⁰⁴ Some Big Bang theorists invoke the Heisenberg Uncertainty Principle to excuse themselves from having to explain the origin of matter. Since the Uncertainty Principle holds that a particle's position and momentum ($\Delta E \Delta t \leq h/2\pi$), or its energy and time ($\Delta x \Delta p \leq h/2\pi$), cannot be known, its advocates conclude that such limitations preclude the discovery of the origin of matter. This solution puts the cart before the horse, as it were, since the Heisenberg Uncertainty Principle was originally derived from the study of already existing matter and thus cannot be applied to pre-existing states. Moreover, the Uncertainty Principle allows for at least one of the needed components (i.e., either position or momentum in $\Delta E \Delta t \leq h/2\pi$; or energy or time in $\Delta x \Delta p \leq h/2\pi$), thus forcing the theorists to choose at least one for the beginning of the Big Bang. But even if the Uncertainty Principle were invoked, the theorists must then confront the Entropy law, which holds that the initial explosion would tend to increasing disorder, not to the order we see today.

We are the local embodiment of a Cosmos grown to self-awareness. We have begun to contemplate our origins. We are star-stuff pondering the stars!... Our ancestors worshipped the Sun, and they were not that foolish. It makes sense to revere the Sun and the stars, for we are their children.¹¹⁰⁵

After Gamow and company, more and more powerful telescopes were built. The universe Hubble saw in 1929 was being dwarfed by what men were discovering in the last half of the twentieth century (at least with the formulas they currently use to measure astral distances). The universe was no longer measured in megaparsecs but gigaparsecs.¹¹⁰⁶ But if one enforced the Doppler interpretation of redshifts on a universe that was gigaparsecs in size, Hubble's Law would be forced to say that the outer galaxies were receding from Earth faster than the speed of light. The very theory that gave them the expanding universe was now faced with a universe that was, as it were, too big for its britches, and which ends up contradicting Einstein's most cherished fact of life – the violation of *c in vacuo*.

So what did science do? Rather than face embarrassment by having to modify the foundation of its theory, it changed the “expanding” universe into an “exploding” universe, and thus the Big Bang concept was born – that primeval “point of singularity” infinitesimally smaller than the dot of the *i* on this page that, holding all the material of the universe, decided, for whatever reason, to explode about 13.5 billion years ago in a fraction of a second, and is still exploding, producing all that we see in the starry universe today and the recessional speeds to go along with them.¹¹⁰⁷ Here was the key ingredient: As it explodes it is said to “create space,” and thus the galaxies are not receding faster than light, rather, space is created faster

¹¹⁰⁵ *Cosmos*, Carl Sagan, Random House, 1980, p. 243.

¹¹⁰⁶ A gigaparsec is 1000 megaparsecs. 50 gigaparsecs equal 1.5×10^{11} light years, as opposed to one megaparsec, which equals 3.3×10^6 light years.

¹¹⁰⁷ The theorists hold that the Big Bang started 13.5 billion years ago in the Planck dimensions from a volume of 10^{-40} cubic centimeters with a diameter of 3.14×10^{-13} centimeters, and was filled with particles of 1.62×10^{-33} centimeters packed solidly and having a density of 4.22×10^{93} , and a gravitational attraction between each particle of 1.3×10^{49} dynes (roughly 10^{46} greater than Earth's gravity). The Planck dimensions are conveniently chosen in order to avoid the infinite dimensions demanded by a singularity. The advocates postulate that a group of these Planck particles numbering 10^{60} spontaneously broke away, creating a hole of 3.14×10^{-13} centimeters in diameter but which was filled in 2×10^{-23} seconds. For some unexplained reason, the implosion does not reabsorb the 10^{60} particles (even though the gravitational attraction is immense), and the 10^{60} Planck particles do not remember that they are supposed to cease existing in 4×10^{-44} seconds but keep expanding into what we now have as the present universe (satirically described by G. Bouw in *The Biblical Astronomer*, vol. 12, no. 99, 2002 and vol. 13, no. 104).

than light can travel, and the galaxies are merely being pulled along with the expansion so it only appears as if they are traveling faster than light. If one asks: “Where is the new space created during expansion?” theorists such as Misner, Thorne and Wheeler retort: “That is a meaningless question.”¹¹⁰⁸ Once again, science pulled the proverbial rabbit out of the hat.

¹¹⁰⁸ *Gravitation*, p. 739.

The Anti-Big Bang Movement

Tom Van Flandern remarks:

The Big Bang theory is the accepted model for the origin of the universe. This theory requires us to accept the following...that all the matter and energy in the entire universe were contained in an infinitesimal point at the “beginning”; that for some unknown reason it all exploded; that space and time themselves expanded out of that explosion; that at first space expanded faster than the speed of light; that the explosion was so uniform it emitted an almost perfectly uniform radiation everywhere; and the same explosion was non-uniform enough to create the observed, quite irregular matter distribution in the universe; that the chaos from the explosion eventually organized itself into the structures presently seen in the universe, contrary to the principle of entropy (which basically states that you shouldn’t get order out of chaos); that all matter in the universe expands away from all other matter as space itself continues to expand, although there is no center; that the expansion of space itself occurs between all galactic clusters and larger structures, but does not occur at all on scales as small as individual galaxies or the solar system; that vast assemblies of galaxies stream through space together relative to other assemblies; and that immense voids separate immense walls of galaxies, all condensed from the same explosion.¹¹⁰⁹

When the Big Bang theory was in its infancy, the well-respected astronomer **Robert Dicke** offered this sobering assessment of its unlikelihood:

The puzzle here is the following: how did the initial explosion become started with such precision, the outward radial motion became so finely adjusted as to enable the various parts of the Universe to fly apart while continuously slowing in the rate of expansion? There seems to be no fundamental theoretical reason for such a fine balance. If the fireball had expanded only 0.1 per cent faster, the present rate of expansion would have been 3×10^3 times as great. Had the initial expansion rate been 0.1 per cent less and the Universe would have expanded to only

¹¹⁰⁹ Tom Van Flandern, *Dark Matter, Missing Planets and New Comets*, Berkeley, CA: North Atlantic Books, 1993, p. xvi. In another instance he adds: “...it should not be forgotten that it is not even certain that the universe is presently expanding (as opposed to contracting) even within the context of the Big Bang theory. Sumner has recently argued that the new space introduced by the expansion must dilute the permittivity of the vacuum, which in turn must alter the frequency of electrons around atoms. This affects observed redshift twice as strongly as the speed of expansion. When this consideration is factored into the equations, it turns out that the present universe is actually collapsing, not expanding, under Big Bang premises!” (*ibid.*, p. 400).

3×10^{-6} of its present radius before collapsing. At this maximum radius the density of ordinary matter would have been 10^{-12} gm/cm³, over 10^{16} times as great as the present mass density. No stars could have formed in such a Universe, for it would not have existed long enough to form stars.¹¹¹⁰

Of course, we must not hesitate to add that, as convincing as scientists ‘in the know’ can make the Big Bang appear, still, the alternatives offered by what are known as “dissident” astronomers and physicists is not really much better. We catch the alternative in Van Flandern’s opening remarks of his critique: “This theory [the Big Bang] requires us to accept the following: time and space have not always existed; both began a finite time ago; and both the age and size of the universe are finite.” What Van Flandern is pushing for, as are all the other “dissident” cosmologists such as Halton Arp, Eric Lerner, Michael Ibison, Hermann Bondi, Paul Marmet, Jayant Narlikar, Sisir Roy, and many others, is “an evolving universe without beginning or end,”¹¹¹¹ a return to the “Steady-State” model, the same one proposed by Arthur Eddington and which Lemaître turned into the “cosmic egg.”

But the infinite universe is an equally ridiculous concept. As we will see below, although it doesn’t have the process problems of the Big Bang, it has origin problems, since it obviously has no origin. Except for God, anything that doesn’t have an origin is a logical fallacy. Even God cannot create something infinite, for what is infinite is God. As we noted, beginning with Isaac Newton, there has been a war occurring in cosmological circles between the finite universe and the infinite universe, with no end in sight. Although both theories are wrong, at least the “cosmic egg” theory is a step closer to reality, since its foundation is that there was a “beginning” to it all. The biblical account tells us, however, that the primordial “egg” of the Big Bang was not a

¹¹¹⁰ Robert H. Dicke, *Gravitation and the Universe*, Jayne Lectures for 1969, American Philosophical Society, Independence Square, Philadelphia, 1970, p. 62.

¹¹¹¹ So stated by Eric Lerner in “An Open Letter to the Scientific Community,” *New Scientist*, May 22, 2004, p. 20, as he represents thirty-three other signers to the document. Lerner writes: “...the Big Bang is not the only framework available for understanding the history of the universe. Plasma cosmology and the steady-state model both hypothesize an evolving universe without beginning or end.” Again on July 2, 2005, *New Scientist* quotes Lerner: “This isn’t science. Big Bang predictions are consistently wrong and are being fixed after the event,” the editor adding that “So much so, that today’s ‘standard model’ of cosmology has become an ugly mishmash comprising the basic Big Bang theory, inflation and a generous helping of dark matter and dark energy” (Marcus Chown in “The End of the Beginning,” *New Scientist*, July 2, 2005, p. 30). In his major work on the subject, Lerner adds: “If the Big Bang hypothesis is wrong, then the foundation of modern particle physics collapses and entirely new approaches are required. Indeed, particle physics also suffers from an increasing contradiction between theory and experiment” (Eric J. Lerner, *The Big Bang Never Happened*, New York, Random House, 1991, p. 4).

“singularity,” but the Earth itself, called into being before any other heavenly body by the one who is Uncreated.

Redshift and the New Alternative

As we noted earlier, there is quite a divergence of opinion regarding the interpretation of redshift. The Big Bang theory says that we see a redshift in starlight because the light's wavelength is stretched. Longer waves produce a shift to the red end of the spectrum of white light. The light is stretched because, as other components of the Big Bang theory state, the stars are receding from the Earth at tremendous speeds, and therefore, when the light leaves from this rapidly moving star, since it must travel at the same speed, c , and cover the same distance over time, the only way to compensate for these factors is for the light to have a longer wavelength. This is almost common knowledge today.

What is not so commonly known but is vitally important in understanding why Big Bang theorists (besides their philosophical presuppositions) hold to such an exclusive interpretation of the redshift is that they are invariably advocates of Relativity theory, a theory positing that space is void, that is, it lacks any kind of material substance. Space, to the Relativist, is not an independent entity but is created and molded by gravitational pockets all over the universe. When space is so molded it is a vacuum (except, of course, for the matter that created it). As such, light traveling from a star has nothing physical with which to interact, and therefore nothing in space can interfere with the light as it travels. As far as Relativity is concerned, light is always traveling in a pristine environment in outer space, supposedly making its own electromagnetic medium as it travels. Hence, the only possible explanation for why redshift appears in starlight is that it is due to the motion of the star, specifically the supposed recession of the star away from Earth, i.e., the expanding universe theory.

But the problem with the Big Bang's interpretation of the redshift is that it is not in the least supported by the hard data from observation. One of the Big Bang's chief opponents is astronomer [Halton Arp](#). Although we must say at the outset that Arp's alternative "infinite" universe is also erroneous, nevertheless, we can use his vast research to show that the Big Bang's interpretation of redshift finds itself in the same mistaken category.

Arp was at one time an associate of [Edwin Hubble](#), but as of this date he is the black sheep of the astrophysical community because, like Hubble and Humason, he dared to suggest an alternative to the expanding universe concept. Arp was systematically marginalized after his extensive work on the redshifts of quasars and galaxies indicated the universe was *not* expanding. As [astrophysicist Jayant Narlikar](#) writes:

The ludicrous climax came about ten years ago when Arp was denied the use of telescopes in major observatories. The reason given was that his findings "did not make sense," and were therefore a "waste of time." In other words, telescopes are

meant only to confirm the established ideas and not turn up anomalous data.¹¹¹²

The ostracizing of Arp and the ignoring of his evidence shows quite clearly the personal agendas and the ignorance abounding in the halls of science today. Regardless of whether Arp's interpretation of redshift is correct, it is quite clear that the science establishment is refusing to consider the evidence based upon its biased presuppositions and its desire to preserve the *status quo*. According to Arp, it is easy to figure out why:

[I]f the cause of these redshifts is misunderstood, then distances can be wrong by factors of 10 to 100, and luminosities and masses will be wrong by factors up to 10,000. We would have a totally erroneous picture of extragalactic space, and be faced with one of the most embarrassing boondoggles in our intellectual history.¹¹¹³

Similar to the “embarrassing boondoggle” caused by the 1887 Michelson-Morley experiment (by which, if Relativity had not come along as the remedy, everyone would be back to a pre-Copernican cosmos), so present cosmologists are looking for a savior to relieve them of having to accept a smaller universe. As we noted earlier, one candidate for their salvation is Dark Matter, and its companion, Dark Energy. No one has ever seen either of these constituents, but the Big Bang theory says they are there, nevertheless.

Throughout his book Arp shows detailed, observatory evidence why the Big Bang interpretation of redshift is erroneous. From an analysis of X-ray sources, Seyfert Galaxies, Companion Galaxies, individual stars in the same galaxy, clusters of galaxies, and a critique of the so-called “gravitational lensing” effect, Arp makes quite a convincing case. His alternate view postulates that:

¹¹¹² *Times of India*, July 30, 1994. Astrophysicist Paul Marmet concurs: “Science is said to be about searching for truth, but the harsh reality is that those whose views clash with established theories often find themselves ridiculed and denied funds and publications.” www.newtonphysics.on.ca. Arp writes in his new book, *Seeing Red*, concerning his first book, *Quasars, Redshifts and Controversies*: “...the book became a list of topics and objects to be avoided at all cost. Most professional astronomers had no intention of reading about things that were contrary to what they knew to be correct. Their interest usually reached only as far as using the library copy to see if their name was in the index....More than 10 years have passed and, in spite of determined opposition, I believe the observational evidence has become overwhelming, and the Big Bang has in reality been toppled” (*Seeing Red: Redshifts, Cosmology and Academic Science*, Montreal, *Apeiron*, 1998, pp. i,ii)

¹¹¹³ *Seeing Red*, p. 1.

On the theoretical front it has become more persuasive that particle masses determine intrinsic redshifts and that these change with cosmic age. Therefore episodic creation of matter will imprint redshift steps on objects created at different epochs. In addition it appears increasingly useful to view particle masses to be communicated by wave like carriers in a Machian universe.¹¹¹⁴

Thus, Arp postulates that redshift is an indication of age, wherein newly “created” objects will have a higher redshift. But it appears that Arp is making the same assumption regarding Carl Anderson’s 1932 discovery of the positron that Big Bang theorists made. In fact, Arp refers to the very process of electron-positron creation.¹¹¹⁵ This view, of course, has a very difficult time preserving the First Law of Thermodynamics. Suffice it to say, there is a mixing and matching of various theories and observations in astrophysics today because, basically, no one really knows what is going on in the universe. As we noted earlier from astronomer Fred Hoyle: “The whole history of science shows that each generation finds the universe to be stranger than the preceding generation ever conceived it to be.”¹¹¹⁶

Accordingly, Arp holds that the “tired light” theory for redshift is discounted by the fact that: (a) no increase in redshift has been seen from light traveling through dense galactic material; (b) that some quasars which are close together have vastly different redshifts; (c) that younger quasars have higher redshifts; (d) that the Butcher-Oemler effect shows

¹¹¹⁴ *Seeing Red: Redshifts, Cosmology and Academic Science*, p. 195. He adds: “In 1993, Jayant Narlikar and I had published a paper outlining how newly created matter would have a high redshift, and demonstrated how to account quantitatively for quasar and galaxy redshifts as a function of their age” (*ibid.*, p. 137).

¹¹¹⁵ He writes: “As for the creation of matter from a zero mass state [Arp’s view], it is often objected that pair *creation* of electrons and positrons from photons in terrestrial laboratories does not produce low-mass electrons. The answer must be that these photons are localized packets of energy and the *created* electrons and positrons are local entities – not drawn from elsewhere in the universe” (*ibid.*, p. 234); Arp also refers to the decay of the “Planck particle” as another source of the creation of matter: “Also in 1993, however, Fred Hoyle, Geoffrey Burbidge and Jayant Narlikar introduced the quasi-steady state cosmology (QSSC). There they *created* the matter in the form of Planck particles. The mass of the present day Planck particle is about 10^{19} GeV/c². In the short time scale of about 10^{-43} seconds the particle is unstable and decays into baryons and mesons...the Planck particle is *created* in the Quantum Gravity era...” (*ibid.*, pp. 137-138, emphasis added); “It is natural to think of the ‘material vacuum’ or the ‘zero point energy field’ as possible thermalizing components in intergalactic space. This is simply saying that there is no such thing as empty space – that it contains at least some electromagnetic field and possibly quantum creation and annihilation and/or virtual particles. For example, newly created low mass electrons would be extremely efficient radiation thermalizers” (*ibid.*, p. 237).

¹¹¹⁶ Fred Hoyle, *Astronomy and Cosmology*, San Francisco, W. H. Freeman and Co, 1975, p. 48.

galaxies of moderate redshift have blue and ultraviolet light; and (e) that high redshift quasars are often in the middle of low redshift galaxies (e.g., *The Einstein Cross* – G2237+ 0305).¹¹¹⁷

Irrespective of his alternate theory, the fact is that Arp still believes in a “much older, larger universe,”¹¹¹⁸ and, as noted, supports his new method for his preferred cosmogony by appealing to the “creation” of matter. He believes his theory is correct because he simply has no other explanation for the origin of matter in his infinite universe, and thus, he has no qualms positing that the universe continues what it has been doing for eternity, that is, creating matter all by itself. Hence, not only is Arp’s concept just as speculative and bizarre as that of the Big Bang theorists whom he critiques, he is also positioning himself against the biblical perspective since Holy Writ assures us that matter was called into being by its Creator; that creation was limited to six days, and that the appearance of inorganic matter in the cosmos was completed on the Fourth of the days of creation.

Further, as much as Arp is against Big Bang cosmologists, he is a firm supporter of Relativity theory and the Copernican universe, since he makes it quite evident that he refuses to interpret the periodicity of redshift as an indicator of the centrality of Earth. Arp writes:

For supposed recession velocities of quasars, to measure equal steps in all directions in the sky means we are at the center of a series of explosions. *This is an anti-Copernican embarrassment.* So a simple glance at the evidence discussed in this Chapter shows that extragalactic redshifts, in general, cannot be velocities. Hence the whole foundation of extragalactic astronomy and Big Bang theory is swept away.¹¹¹⁹

Note how Arp assumes as his foundational truth that Earth is *not* in the center of the universe and, in fact, he uses this premise as a goad to embarrass the Big Bang theorists. In fact, we might say that Arp’s alternative hypothesis regarding redshift is for the express purpose of

¹¹¹⁷ Ya. B. Zel’dovich adds: “If the energy loss is caused by an interaction with the intergalactic matter, it is accompanied by a transfer of momentum; that is, there is a change of the direction of motion of the photon. There would then be a smearing out of images; a distant star would be seen as a disc, not a point, and that is not what is observed....if the decay of photons is possible at all, those in radio waves must decay especially rapidly! This would mean that the Maxwell equation for a static electric field would have to be changed....There is no experimental indication of such effects: the radio-frequency radiation from distant sources is transmitted to us not a bit more poorly than visible light, and the red shift measured in different parts of the spectrum is exactly the same...” (Misner, Thorne and Wheeler, *Gravitation*, p. 775).

¹¹¹⁸ *Seeing Red*, p. 8.

¹¹¹⁹ *Seeing Red*, p. 195, emphasis added.

trying to solve the Copernican dilemma created by the Big Bang. Unfortunately for Arp, the reality is that he is in the same dilemma as the Big Bang theorists he critiques.

The Use and Abuse of Stellar Parallax

Regarding the size and limits of the universe, if there is one cosmological phenomenon that has been consistently avocated as the vindicator of heliocentrism, it is stellar parallax. Science books by the hundreds have declared that Frederich Bessel finally discovered heliocentrism's long-awaited proof when, in 1838, he observed a slight shift in the position of a nearby star (Cygnus 61) against the background of a more distant star. Copernican astronomers continue to praise Bessel, but invariably they do so without either the slightest indication that parallax does not prove heliocentrism, or any admission that there is a perfectly good alternative which allows one to interpret parallax from a geocentric perspective. For example, Alan Hirshfeld, writing one of the more recent books on parallax, attempts to convince his reader that parallax is last word of the heliocentric/geocentric debate:

In Newton's day, the Ptolemaic system and the Keplerian version of the Copernican system were taught side by side in the universities of the world. But the pendulum of belief had swung irreversibly to the Copernican side. In the minds of most scientists, the heliocentric universe had become fact. . . Yet there remained a crucial missing element in what was otherwise a complete and compelling picture of the universe: *Not one shred of indisputable observational proof existed that the Earth moved through space.* Here then was the holy grail of many an astronomer. To prove that the Earth in fact revolved in a wide orbit around the Sun, the parallax of just one star – any star – had to be detected. The hunt for stellar parallax was on.¹¹²⁰

Before we get into Hirshfeld's analysis of parallax, we pause to note his revelation concerning how heliocentrism was accepted. Hirshfeld admits that even prior to the discovery of what he deems as "indisputable observational proof," modern science had already accepted heliocentrism as a "fact." One wonders why this glaring anachronism that puts "fact" before "indisputable observational proof" doesn't cause Hirshfeld any concern, but there it is nonetheless. Of course, Hirshfeld's attempt to put fact before proof will become even more egregious when we show that not even parallax offers the "indisputable observational proof" that he is seeking. If Hirshfeld is ignorant of the inability of parallax to prove heliocentrism, then it shows how badly he and the modern science he represents are out of touch with reality. In effect, Hirshfeld's anachronism gives us a clear example of the underlying bias in the Copernican establishment, for it demonstrates quite handily that it was not by any fact of science that heliocentrism reached acceptance, but

¹¹²⁰ Alan Hirshfeld, *The Race to Measure the Cosmos*, New York, W. H. Freeman and Co., 2001, p. 47, emphasis added.

only because “most scientists” had already made up their minds based on little more than their philosophical preferences.

How Parallax Measures Distance

First, we will investigate a little history about parallax measurements. Parallaxes have been measured for thousands of stars. For only about 700 stars, however, are the parallaxes large enough to be measured with a precision of 10 percent or better. Of those 700 stars, most of the ones within 20 parsecs from Earth are invisible to the unaided eye and are intrinsically less luminous than our sun. The vast majority of all known stars are too distant for their parallaxes to be measured, and science must resort to non-empirical methods. Most of these methods are either statistical or indirect.¹¹²¹

With the advent of the Hipparcos satellite launched in 1989 by the European Space Agency, its telescopes gathered 3.5 years worth of data on stellar positions and magnitudes, which were eventually published in 1997. Viewing the stars through two telescopes 58 degrees apart, Hipparcos measured the parallax of 118,000 selected stars within an accuracy of 0.001 seconds of arc. This accuracy is comparable to viewing a baseball in Los Angeles from a telescope in New York. Another mission, named Tycho (after Tycho de Brahe) measured the parallax of a million stars, but only to an accuracy of 0.01 seconds of arc.

As accurate as these measurements appear to be, the reality is, beyond 100 light years, it is hardly possible to measure an accurate parallax. Even within 20 light-years, parallax measurements are accurate only to within one light-year. At 50 light-years from Earth the error could be as high as 5-10 light-years in distance. All in all, within a 10% margin of error, Hipparcos measured the parallaxes of about 28,000 stars of up to 300 light-years from Earth. For any star beyond 300 light years, scientists are forced to estimate its distance from Earth by other means, none of which are proven methods of measurement (e.g., redshift).¹¹²²

¹¹²¹ George Abell, *Exploration of the Universe*, New York: Holt, Rinehart and Winston, 1969, pp. 377-378.

¹¹²² Other methods of determining parallax include: Photometric parallaxes, which are found by estimating a star's absolute magnitude (M) based on a spectral classification, and comparing that with its apparent magnitude (m). Statistical parallaxes could perhaps extend to 500 parsecs, but this only applies to groups of stars, not individual stars. Overall, of the half dozen or so methods employed today to measure astral distances, none of them are indisputable (including distances measured by redshift, Cepheid variables, luminosity, color of stars, etc.). There is only one purely empirical method, parallax (and its attendant modifications such as Spectroscopic, Moving Cluster Method, and Statistical Method), but it is quite limited in its applicability, since it can accurately measure only a thousand or so stars. In effect, modern science is left without an irrefutable means to measure cosmological distances, and thus all the literature espousing that stars, galaxies or quasars are billions of light years away from

To understand how parallax is formed, in front of your face, place your finger from your right hand at arms length and align it with a finger from your left hand at half an arm's length. Observe your fingers first with your right eye open and then with your left eye open. As you switch your vision from one eye to the other, the nearer finger will appear to shift to the right.

In the heliocentric system, parallax is said to occur when, on one side of the Earth's orbit, say January 1, two stars are viewed at the same time in a telescope, one star near us and the other star far away (at least by conventional means to measure star distances). Let's say that the two stars we view on January 1 are aligned vertically in the same plane, that is, one star is at a higher position in our telescope lens than the other but both are on the same vertical line. Six months passes and we look at the same two stars on June 1. If parallax is demonstrated, we will see that the stars are not in a vertical alignment any longer. Assuming the Earth has orbited in a counterclockwise direction, the nearer star appears to have shifted to the right. This is due to the fact that, in the interval of six months, one has looked at the two stars from two separate locations that are 185 million miles apart (the diameter of the Earth's orbit). Since astronomers can now detect stellar parallax among a select few stars, they are predisposed to allowing the Copernican worldview to interpret the phenomenon as proof for the Earth's movement around the sun.

What most people do not know (and what most scientists keep from them) is that in the geocentric system the same optical phenomenon can be demonstrated. In the geocentric system, the stars are centered on the sun, (which is also true in the heliocentric system). The only difference, of course, is that in the geocentric system the Earth is fixed in space while the sun and stars revolve counterclockwise around the Earth. On January 1 we will notice that the two stars from our above example are in vertical alignment. When we look at these same two stars again on June 1 as the sun and stars have traveled halfway across the sky, the nearer star will appear to have shifted to the right of the farther star, at the same precise angle as in the heliocentric model. (To see animation of parallax from both a heliocentric and geocentric system, go to the menu button on the compact disc).

This equivalence of the geocentric parallax to the heliocentric parallax is nothing out of the ordinary. Based on geometrical reciprocity, the two systems must be equal on all counts. The only difference is that in the heliocentric model the Earth is moving and the stars are fixed, while in the geocentric model the Earth is fixed and the stars are moving. What is out of the ordinary, however, is that the natural equivalence between the two systems has been systematically suppressed out of

Earth is an unproven scientific assertion. Using Cepheid variables, for example, is certainly a question-begging venture, since Cepheids are too far away to be measured by parallax and, thus, depends on an unproven statistical method to measure distance.

almost every science book written since the days of Newton, yet it is as simple and natural as the symmetry between one's right hand and left hand. By the mere fact of the equivalence, parallax does not prove heliocentrism. Rather, history shows that the phenomenon of parallax only proves there has been a rush to judgment in favor of heliocentrism that was based on nothing more than preference, not scientific fact.

The Neo-Tychonic Model

One stumbling block toward understanding the equivalence between the heliocentric and geocentric concepts of parallax is that the original model of geocentrism advocated by Tycho Brahe did not have the stars centered on the sun; they were centered on the Earth. That being the case, no parallax would be detected, at least based on the above mechanics and geometric proportions. That is, the stars would be in the same vertical alignment when one looked at them six months apart. Perhaps no one in Bessel's day realized that the only thing required to bring the geocentric model into conformity with the results of heliocentric model was to shift the center of the stars from the Earth to the sun. Consequently, the geocentric model that had the stars centered on the sun never gained its rightful place in the halls of astronomy. Tycho Brahe had not presented such a model because in his day (1546-1601) no one had yet discovered a stellar parallax, and, in fact, this lacuna in the astronomical evidence was one of the arguments Tycho used to discredit heliocentrism. As it stands now, however, unless some astronomical proof is forthcoming that demonstrates that the stars are not centered on the sun (which is virtually impossible to do based on observation), then geocentrism has the same mechanical answer to the phenomenon of parallax as the heliocentric model. All that is needed is a slight modification to the original Tychonic model, which most geocentrists know as the modified or neo-Tychonic model.

The neo-Tychonic model has been known to modern astronomy for quite some time and is still mentioned in some circles. For example, at the department of physics at the University of Illinois, one class lecture states:

It is often said that Tycho's model implies the absence of parallax, and that Copernicus' requires parallax. However, it would not be a major conceptual change to have the stars orbit the sun (like the planets) for Tycho, which would give the same yearly shifts in their apparent positions as parallax gives. Thus if parallax were observed, a flexible Tychonean could adjust the theory to account for it, without undue complexity. What if parallax were not observed? For Copernicus, one only requires that the stars be far enough away for the parallax to be unmeasurable. Therefore the presence or absence of parallax doesn't force the choice of one type of model over the other. If

different stars were to show different amounts of parallax, that would rule out the possibility of them all being on one sphere, but still not really decide between Tycho and Copernicus.¹¹²³

The same course material adds the following conclusion:

In fact, if we don't worry about the distant stars, these two models describe identical relative motions of all the objects in the solar system. So the role of observation is not as direct as you might have guessed. There is no bare observation that can distinguish whether Tycho (taken broadly) or Copernicus (taken broadly) is right.¹¹²⁴

Some geocentrists, although seeing the merits of the neo-Tychonic model, still prefer to find a solution by retaining the Earth as the center of the orbit of the stars. They prefer this model because they assume Scripture puts Earth at the exact center of the circling stars. If this is a correct understanding of the relationship between the stars and the Earth, it will require an entirely different explanation for stellar parallax. The proposed explanation is that the light from the two stars will be distorted by its movement through the cosmic medium, and/or distorted by the sun's gravitational pull on the light. Since one star is farther away from the other, the amount of distortion between them will be proportionally different, and thus one star will be shifted against the other. The ray of light, as it were, is moved out of its normal path into a slightly different path before it reaches our telescope. This is very similar to the concept of stellar aberration that we analyzed earlier concerning [James Bradley's](#) discovery in 1728 of the ellipse formed over a period of a year by the star *Gamma Draconis*. In that case either the light from *Gamma Draconis* was shifted due to the finite speed of light having to travel such a great distance, or because the light is affected by the medium due to its long journey. As such, stellar aberration and parallax are the same phenomenon in the unmodified Tychonic model, whereas in the neo-Tychonic model, they are distinct.¹¹²⁵

All things being equal, the neo-Tychonic model is the simplest explanation of geocentric parallax, and consequently, as Bradley found, stellar aberration would be a different phenomenon than parallax. Not only is the neo-Tychonic model a more sound explanation of parallax with respect to the geometry (for it is simply a mirror image of the heliocentric model), but also because it is able to incorporate the vast

¹¹²³ University of Illinois, Physics 319, Spring 2004, Lecture 03, p. 8. In the last few years the same explanation for parallax has been promoted by astronomer Gerardus Bouw. He has also coined the term "modified Tychonic model" (*Geocentricity*, Association for Biblical Astronomy, Cleveland, 1992, p. 232).

¹¹²⁴ University of Illinois, Physics 319, Spring 2004, Lecture 03, p. 8.

¹¹²⁵ The unmodified Tychonic model was advocated by Walter van der Kamp.

distances to the stars, if, indeed, it is a fact that the stars are very far away. The unmodified Tychonic model works better, and is designed for, a smaller universe, while the neo-Tychonic model has no problem sustaining the gigaparsec sizes we commonly hear associated with modern astronomy.

More importantly, since those who are persuaded to an unmodified Tychonic model do so out of an allegiance to the assumption that Earth must be the center of the stellar revolutions, it is this very assumption that brings the validity of the model into question. Scripture does not say that the Earth is the center for the stars; it says only that the Earth is immobile. Granted, one can certainly advance an argument that the Earth should assume the center position based on nothing more than the definition of immobility within a sphere. Geometrically speaking, the only point that would not move, relative to the rest of the rotating sphere, is the exact center. Yet this fact merely begs the question: what constitutes the sphere of which Earth is the immobile center? Do the stars themselves define the universal sphere, or is the universal sphere defined by itself? By force of logic, we are compelled to say that the stars are merely *contained within* the universal sphere, but are not necessarily the composite body by which the sphere is defined. This is especially true when we understand that, besides the stars and other celestial bodies comprising the universe, the universal sphere has its own substance (ether), and thus it has a mass and velocity independent of the stars. It is the universe's own mass that is rotating around the immobile Earth, and as it does so, it carries the stars with it. As such, there is nothing to prohibit the stars from being slightly shifted to one side of the universal sphere and thus have their center on the sun, whereas the universal sphere itself is centered on the Earth. In fact, if that is the case, we would obtain the characteristic precession or "wobble" that we see in so many sectors of the cosmos. All this can be accomplished by keeping the Earth as the immobile center of the universe.

Finally, in remarking about the equivalence between the geocentric and heliocentric models for parallax, we must reiterate that the parallax in either system is based on the assumption that a vast distance separates the two stars being viewed in the telescope. But this is only an *assumption*, not a proven fact. Although we presently work from the assumption given to us by modern astronomy that the stars are very large and very far away, there is no indisputable proof for that conclusion. The stars could be very close and very small. Even with the finest optical telescopes, the stars and galaxies remain as mere points of light through our telescope lenses. No one has ever obtained a finer focal point. In fact, modern astronomy has found that the stars have a much smaller angular size than previously estimated. Logically, then, it is impossible to be absolutely certain whether the star is large and distant as opposed to small and near based only on its size and luminosity.

Recently the research team of astronomer Roberto Ragazzoni of the Astrophysical Observatory in Arcetri, Italy studied two images from the Hubble space telescope: one of a galaxy calculated to be 5 billion light years from Earth and another of an exploding star 42 million light years away. Although similar pictures have been produced by Hubble space telescope for quite a while, Ragazzoni is apparently the first one to notice that no matter how far away the object are purported to be, the Hubble pictures are always crisp and clear, never out of focus. With regard to the Big Bang theory, this creates a problem. Ragazzoni explains:

You don't see a universe that is blurred. If you take any Hubble Space Telescope Deep Field image you see sharp images, which is enough to tell us that the light has not been distorted or perturbed by fluctuations in space-time from the source to the observer.¹¹²⁶

Ragazzoni, et al., interpret the lack of distortion to apparent discrepancies in Quantum mechanics that theorizes a Planck-scale ether between the star and the observer. They write:

It has been noted (Lieu & Hillmann) that the cumulative effect of Planck-scale phenomenology, or the structure of spacetime at extremely small scales, can lead to the loss of the phase radiation emitted at large distances from the observer. We elaborate on such an approach and demonstrate that such an effect would lead to an apparent blurring of distant point sources. Evidence of the diffraction pattern from the Hubble Space Telescope observations of SN 1994D and the unresolved appearance of a Hubble Deep Field galaxy at $z = 5.34$ lead us to put stringent limits on the effects of Planck-scale phenomenology.¹¹²⁷

Yet one might just as well interpret the lack of distortion to the fact that the exploding star and the galaxy are not separated by 4.958 billion light years of space but are relatively close to one another; that neither the star nor the galaxy are very far away from Earth; and/or that the redshift of 5.34 assigned to the galaxy is not measuring its distance but its own peculiar radiation.

¹¹²⁶ Robert Roy Britt, Space.com, April 2, 2003 interviewing Roberto Ragazzoni concerning the article "The Lack of Observational Evidence for the Quantum Structure of Spacetime at Planck Scales," *The Astrophysical Journal*, April 10, 2003, co-authored by Massimo Turatto and Wolfgang Gaessler.

¹¹²⁷ "The Lack of Observational Evidence for the Quantum Structure of Spacetime at Planck Scales," *The Astrophysical Journal*, April 10, 2003, p. L1.

Various modern astronomers freely admit that the starry cosmos might be very close to us and not as vast as present cosmology dictates. In fact, one theory holds that much of what we see in the heavens beyond a certain point is a mere reflection. For example, the well-known astrophysicist of Princeton University, David Spergel, has recently found such evidence. Working alongside mathematician Jeffrey Weeks, *New Scientist* reports:

Scientists have announced tantalizing hints that the universe is actually relatively small, with a hall-of-mirrors illusion tricking us into thinking that space stretches on forever....Weeks and his colleagues, a team of astrophysicists in France, say the WMAP results suggest that the universe is not only small, but that space wraps back on itself in a bizarre way (*Nature*, vol. 425, p. 593)...Effectively, the universe would be like a hall of mirrors, with the wraparound effect producing multiple images of everything inside.” Spergel adds: “If we could prove that the universe was finite and small, that would be Earth-shattering. It would really change our view of the universe.”¹¹²⁸

In any case, applying parallax to the measure of stellar distances has its limitations. Its advocates admit that it cannot do so accurately beyond 300 light-years. Empirically speaking, then, no one is required to commit himself to a universe greater in size than 600 light-years in diameter. Any claims to something larger are simply not conclusive, since it has become obvious that, with all the anomalies associated with measuring distance by a star’s redshift, we have no indisputable yardstick to measure the universe.¹¹²⁹

One other possible indication for a smaller universe is that stellar ellipses are all about the same size, although some have more eccentricity than others. As the reasoning goes: ellipses of the same size suggest that the stars are not very far apart. Moreover, if parallax is

¹¹²⁸ *New Scientist*, October 8, 2003.

¹¹²⁹ Martin Selbrede poses an interesting possibility for using redshift as a distance indicator, but one totally diverse from the modern Big Bang theory. After citing numerous sources showing the centrifugal force is caused by the rotation of the cosmic mass, Selbrede adds that the upward pull caused from the rotation will affect the travel of light from the stars to the earth. Citing Richard Feynman’s *Lectures in Physics*, vol. 2, pp. 42-10 and 42-11, and Misner, Thorne and Wheeler’s discussion 38.5 “Tests of Geodesic Motion: Gravitational Redshift Experiments” in their book *Gravitation*, pp. 1055-1060, Selbrede theorizes that redshift is not a Doppler phenomenon initiated by a receding star, but a gravitational/centrifugal phenomenon of a rotating star field. If so, he concludes: “This in turn would provide a new basis for measuring the distance of celestial objects, one wholly different than the system erected upon the Doppler view of the red shift, which could involve a significant remapping of the heavens” (*The Chalcedon Report*, 1994, p. 12). Of course, the distances measured would be much less than the distance claimed by Big Bang cosmology.

understood as stellar aberration, this would allow the stellar ellipses to be contained within a small universe of no more than 50 light-days in diameter. In this situation the stars would be encased in a stellatum, a circular band of definite but narrow thickness around the Earth. As Van der Kamp notes:

“Looking at the star Alpha Centauri from an Earth circling the sun, parallax measurements and trigonometry would assure us that the two are 1.3 parsecs, or more than 4.2 light years apart. But looking from an Earth circled by the sun, the distance turns out to be less than one twenty-fifth of that amount.”¹¹³⁰

The first one to propose such an arrangement was Thomas Wright (1750), who held the “grindstone” model wherein the stars were located between two concentric shells around the Earth. Accordingly, one could argue that the various biblical passages referring to the known and unchanging constellations, such as God’s challenge to Job: “Can you bind the chains of the Pleiades, or loose the cords of Orion? Can you lead forth the Mazzaroth [Zodiac] in their season, or can you guide the Bear with its children?”¹¹³¹ imply that constellations can be formed because of the close proximity of its stars. It is also possible, however, to explain the appearance of these constellations simply because a few stars near the Earth can form the configuration, while other stars are too far away from Earth to form any visible constellations for the observer.

Although a small universe encased by a stellatum is certainly possible, ultimately it makes little difference to the geocentric model whether the universe is large, small, or somewhere in between. [Gerardus Bouw](#) has argued for a large universe (although by his own admission he is not absolutely committed to it, provided the physics of a small universe can be adequately explained). Bouw has four basic arguments for a large universe: (1) aberration is not parallax;¹¹³² (2) the

¹¹³⁰ Walter van der Kamp, *De Labore Solis*, p. 145.

¹¹³¹ Job 38:31-32, RSV. Some appeal to Apocalypse 6:13’s “And the stars of heaven fell unto the Earth,” but this is not to be understood literally, for John is seeing a symbolic vision in heaven. See my book: *The Catholic Apologetics Study Bible*, Vol. 2, *The Apocalypse of St. John*, Queenship Publishing, 2006.

¹¹³² Bouw’s colleague, Walter van der Kamp, argued for a small universe and thus posited that stellar aberration and parallax were the same phenomenon. To that issue, Bouw writes: “It is significant that the moon, streetlights, and artificial satellites do not exhibit aberration. Any source of light originating inside the earth’s gravitational field does not exhibit aberration. This may mean that aberration originates at the edges of gravitational fields, for the sun and planets do exhibit aberration” (*American Ephemeris and Nautical Almanac*, 1968, pp. x, 485). “That the sun and planets exhibit aberration presents us with the proof against Walter van der Kamp’s thesis that aberration is actually parallax. If Walter’s interpretation is correct, the planets and the sun should not participate in the 20”.496 aberration because they are too close to the earth. Since they do, Walter’s model requires the planets and the sun all to be 58 light-days from the

diameters of expanding nebulae;¹¹³³ (3) measurements of star diameters; (4) the nature of physics. Of these, the fourth is the most comprehensive and thus requires the adoption of Bouw's overall understanding of how the universe is put together. In that understanding, Bouw argues that the "fundamental constants" of physics (e.g., gravity, electric charges, position, time, temperature, entropy, etc.) can only be joined together in a limited number of ways in order that no one constant conflict with the others. Since there is a plurality of fundamental constants, a least common denominator is needed to join them all together. This is accomplished in two ways, both of which are at the extreme ends of the physical spectrum. On the one hand, it is accomplished by reducing the mixing crucible to scales much smaller than atomic particles so that all the necessary constants are represented in their irreducible form; and, on the other hand, to test how these constants react in sizes as big as the universe, which is the ultimate large-scale environment. The crucial constants that need to be joined together are: Planck's constant, Boltzmann's constant, the speed of light, and the gravitational constant. When these constants are combined in their proper proportions, they will provide fundamental units in time, length, charge, mass and temperature, and they will, in turn, give us the corresponding size for the universe. As Bouw understands it:

The size of the atom is about 10^{-13} cm. The size of the nucleus is about a thousandth of that. As we proceed to smaller and smaller scales nothing interesting seems to be happening until we get to a scale of about 10^{-33} cm. At that size called a *Planck length*, fascinating things happen...we find that the warp and woof of heaven comes into focus. Physics attempts to derive relationships between the different properties of objects. Such relationships typically involve certain constants: values which are generally assumed not to change over time. The speed of light is such a constant. So is the gravitational constant. It turns out that there are relationships among these constants

earth, the same distance as the stars....There is another...problem....Unless the stars were [sic] all exactly the same distance from earth, there will be slight differences in their parallax. Indeed, such differences are detected" (*The Biblical Astronomer*, Vol. 4, No. 67, p. 11).

¹¹³³ Bouw uses the star Betelgeuse as an example. Betelgeuse is blowing off gas at a rate of 10 km/sec. "The shell of material around it is 50" (seconds of arc) across. If we assume a 50-light-day universe, then 1 km at the edge of the universe would subtend an angle of about 2×10^{-7} arc sec. This means that in one year Betelgeuse's shell would grow by 49" of arc which, in about 40 years, would grow to the apparent size of the full moon. It would seem from the 50-light-day universe model that Betelgeuse's shell is only about a year old; but the stuff has been seen streaming out of the star for tens of years" (*The Geocentric Papers*, Association for Biblical Astronomy, Cleveland, OH, 1993, p. 38).

themselves, and those relationships all express themselves to specifics at the Planck length.¹¹³⁴

The fundamental units of length and time combine to give the speed of light which is tied to the expansion rate of the universe. Thus from the constants we can derive some large numbers which can be interpreted as the size of the universe, a speed limit for matter (which most scientists today use to infer an age but the quantity is actually determined by the expansion rate of the universe, not its age), and an apparent mass. These quantities, which actually define the laws of physics, are tied to a large universe and not a small universe.¹¹³⁵

One question that remains concerning Bouw's view, however, is whether the *Planck length* is, indeed, the fundamental length. Others have proposed lengths in the 10^{-100} or even smaller scales. Although these infinitesimally small numbers may not detract from a large universe, they certainly would influence how we are to understand its physical makeup and function.

¹¹³⁴ Gerardus D. Bouw, *Geocentricity*, Association for Biblical Astronomy, Cleveland, OH, pp. 324-325.

¹¹³⁵ Gerardus Bouw, *The Geocentric Papers*, p. 39. Bouw qualifies his remarks by only one other possibility for a small universe: "...a model which holds that the parallaxes of stars are not due to a Tychonian-like oscillation of stars and sun about the Earth but are due to the eccentricity of the path which the sun and stars take about the Earth. Since the eccentricity of the Earth-sun path is 0.017, this would make all parallax-based distances about 60 times closer. This would make the nearest star system, Alpha Centauri, to be about 24 light-days distant or about 360,000,000,000 miles. The star would be about 14,500 miles in diameter. Sirius...would be 1.8 light-months distant which would place it 54 light-days out....The main problem with this variant of a small universe is that the physics for such small, hot plasmas (stars) would have to be developed....A non-gravitationally bound plasma would quickly disrupt" (*ibid*).

The earth is vast, and heaven is high, and the sun is swift
in its course, for it makes the circuit of the heavens and
returns to its place in one day.

Is he not great who does these things? But truth is great,
and stronger than all things.

1 Esdras 4:34-35 (apocrypha)

"We're just children looking for answers....As the island of our knowledge grows, so does the shore of our ignorance."

John Wheeler¹¹³⁶

"Never run after a bus or woman or cosmological theory, because there'll always be another one in a few minutes."

Wheeler's Yale acquaintance

"Your sages were wrong to submit to the non-Jewish scholars. They assented to a lie for the truth lay with the Jewish sages."

Tycho Brahe¹¹³⁷

"If it be granted that the Earth moves, it would seem more natural to suppose that there is no system at all, but only scattered globes, than to construct a system of which the sun is the center"

Francis Bacon¹¹³⁸

¹¹³⁶ Interview with John Horgan, as cited in *The End of Science*, p. 83.

¹¹³⁷ Tycho Brahe to Jewish astronomer David Gans. André Neher, *Jewish Thought and the Scientific Revolution of the Sixteenth Century: David Gans (1541-1613) and His Times*, translated from the French by David Maisel, Oxford University Press, 1986, p. 218.

¹¹³⁸ Attributed.

Chapter 10

Mathematical Models of a Geocentric Universe

Geostatism and Geocentrism

In previous chapters we discovered that a geocentric system is geometrically and kinematically the same as a heliocentric system. As Hoyle reminds us: “The equivalence of these two pictures was already known to Apollonius, who lived in the third century, B.C., long before Ptolemy (ca. A.D. 150).”¹¹³⁹ We noted previously from Thomas Kuhn’s analysis of the orrery:

Now imagine that...the whole mechanism is picked up...and put down again with the sun fixed at the central position formerly held by the Earth...All of the geometric spatial relations of the Earth, sun and Mars...are preserved...and since only the fixed point of the mechanism has been changed, all the relative motions must be identical...the Tychonic system is transformed to the Copernican system simply by holding the sun fixed instead of the Earth. The relative motion of the planets are the same in both systems, and the harmonies are therefore preserved.¹¹⁴⁰

The next phase of our investigation must address the matter of how the geocentric system relates to the rest of the universe. It is one thing to demonstrate the equivalence between the heliocentric and geocentric systems in regard to the *annual* motions of the sun and planets, but we also need to explain the [daily motions](#). In the heliocentric system, of course, the daily motion is accounted for by supposing that the Earth rotates on its axis every 24 hours. As such, the sun, moon, and stars will appear to circle the Earth each day. Conversely, the geocentric system holds that the motion of these celestial bodies is a *real* motion and is not an apparent one caused by a rotation of the Earth. In fact, this system would more appropriately be called a “geostatic” system. Whereas “geocentric” literally means that the Earth is the center of the universe, “geostatic” means that the universe is rotating around the Earth, in addition to the fact that the Earth is in the center of the universe.

Explaining a geostatic universe is a little more involved than explaining a geocentric universe. For this very reason, some geocentrists have opted for the model in which the Earth, even though it is the center

¹¹³⁹ Fred Hoyle, *Nicolaus Copernicus*, New York: Harper and Row, 1973, p. 63.

¹¹⁴⁰ Thomas S. Kuhn, *The Copernican Revolution*, New York, Random House, 1959, pp. 204-205.

of the universe, nevertheless, rotates on its axis every 24 hours.¹¹⁴¹ For the dedicated scripturalist, and especially one of the Catholic faith, a rotating Earth in a geocentric universe is not a viable option. First, the condemnation of Copernicanism issued in the papal and Sacred Congregation pronouncements of the seventeenth century included the censoring of the “diurnal movement of the Earth,” that is, it condemned both an Earth that revolved around the sun *and* an Earth that rotated on an axis. We will address these pronouncements in more detail in Volume II of this series. For now we merely note that most geocentrists are also geostatists, simply because, using Scripture as the sole determiner between the heliocentric and geocentric models, it is understood that the Earth does not move at all, either laterally, tangentially, angularly or in any other way. It is the center of the universe and is the only celestial body that does not move. Galaxies, stars, the sun, moon, planets, the cosmic microwave background radiation, and every other celestial object or force are in daily motion around an immovable Earth. In this way, the Earth is the absolute frame of reference for every movement in the sky, and only in this way is the theory of Relativity rendered completely superfluous.

Absolute Rest versus Relative Motion

In reference to Relativity theory, we noted in Chapter 5 that Einstein’s struggle to understand Maxwell’s equations concerning electricity and magnetism demonstrated the difference between absolute rest and relative motion. Let us recall Einstein’s description of this phenomenon:

For if the magnet is in motion and the conductor at rest, there arises in the neighborhood of the magnet an electric field with a certain definite energy, producing a current at the places where parts of the conductor are situated. But if the magnet is stationary and the conductor in motion, no electric field arises in the neighborhood of the magnet. In the conductor, however, we find an electromotive force, to which in itself there is no corresponding energy, but which gives rise – assuming the equality of the relative motion in the two cases discussed – of electric currents of the same path and intensity as those produced by the electric form in the former case.¹¹⁴²

¹¹⁴¹ One example of a geocentric/rotating Earth model is that of Fernand Crombette, which will be critiqued in volume II of this series.

¹¹⁴² Zur Elektrodynamik Bewegter Körper (“On the Electrodynamics of Moving Bodies”), *Annalen der Physik*, Vol. 17, 1905, p. 1.

As we noted previously, the conventional explanation of this phenomenon is: if the conductor is moving toward a stationary magnet, then the electrical charge in the conductor is pulled around the conductor by the force of the magnetic field. Conversely, if the magnet is moving toward the conductor, the increasing magnetic field produces an electric field that drives the charge around the conductor. In order for this to occur, the relationship between the conductor and the magnet cannot be “relative”; rather, we have a case of absolute rest and absolute motion. In Maxwell’s explanation it made a difference whether the magnet or the conductor was at rest, for each case produced a different location for the same electrical current and thus he produced two separate equations for the results. Einstein did not accept Maxwell’s explanation. The reason is noted in the parenthetical statement he adds toward the end of the above paragraph: “...assuming the equality of the relative motion in the two cases discussed...” If the “relative motion” is the same in both cases (that is, a conductor moving toward a stationary magnet is the same as a magnet moving toward a stationary conductor), Einstein assumed that the results should be identical, that is, in both cases the current produced should either be always around the magnet or always around the conductor, and not switch between the magnet and the conductor. Since the results were not identical, Einstein sought to find a reason, but he would do so assuming the principle of Relativity and its application of “fields.”

Having a relativistic explanation to the above phenomenon was very important to Einstein, since it would also provide him with an explanation why the light beams of Michelson-Morley’s interferometer were not affected by the “movement of the Earth.” As Einstein “relativized” Maxwell’s magnet and conductor, so he did with Michelson-Morley’s interferometer. Both experiments were vitally important to him. A solution for one would necessarily be the same for the other. Both had to be relativized or neither could be relativized.

If, for all the reasons we have stated thus far, such “relativizing” of results is prohibited, our only recourse is a system built on absolute rest and absolute motion. In the case of the magnet and the conductor, respectively, we must say that one is at absolute rest while the other is in absolute motion, each “absolute” marked by the production of an electric current in a different location.¹¹⁴³ In the case of the Michelson-Morley experiment, we are left with the absolute rest of the Earth and the absolute motion of the light beams.

In addition, the above phenomenon regarding absolute rest and absolute motion presents a situation in which Einstein’s relativizing of

¹¹⁴³ That is, an object resting on the Earth is in a state of absolute rest, since the Earth is already at absolute rest compared to the rest of the universe. Accordingly, any object in motion on the Earth is in absolute motion, since the Earth is the absolute reference frame against which the object moves.

the Earth's rotation in a fixed universe as co-equivalent to a rotating universe around a fixed Earth, although conceptually equivalent, demands, as does Maxwell's concept of the conductor and magnet, that we dispense with the dualism and insist that ultimately only one can be right. As Maxwell was able to distinguish between whether the magnet or the conductor was moving depending on where the electric current appeared, so it should be possible to perform experiments, or reinterpret already performed experiments, to determine which of the cosmological models is correct.¹¹⁴⁴ We, of course, predict that such experiments, if properly designed, will show that the Earth is in absolute rest and the universe in absolute motion. Laying aside the mathematical "transformation" contortions of Lorentz and Einstein, we already have confirmation that the interferometer and similar experiments demonstrate this to be the case.

¹¹⁴⁴ An experiment demonstrating the difference between the heliocentric and geostatic systems would be based on Maxwell's laws. For example, a charged object at rest on a geostatic Earth should produce no magnetic field if it is placed at the poles or the equator. The same object on a diurnally moving Earth, however, should produce no magnetic field when placed at the poles, but should produce a magnetic field at the equator corresponding to its electric charge multiplied by the rotation velocity of the Earth, which is assumed to be 1054 mph. The magnetic field of the Earth can either be subtracted from the resulting measurements, or the experiment can be preformed in a diamagnetic container (since it excludes external fields). At any latitude the magnetic field will be present, albeit it will be smaller the further away from the equator the experiment is performed. As such, experiments can be performed at two latitudes of considerable distance from each other. If there is no difference between the two respective magnetic fields, then the result is null and the geostatic system has been vindicated. The only experimental difficulty would be to find a way to make the magnetometer be at rest with respect to the center of the Earth.

Fred Hoyle's Geocentrism

The issue regarding whether the Earth is rotating in a fixed universe or the universe is rotating around a fixed Earth has not escaped a few prominent physicists and astronomers. We have already mentioned George Berkeley and Ernst Mach as examples of those who recognized the equivalence between the two systems. Einstein, Eddington, Born and many others found that little argument could be mounted against the equivalence. Yet another prominent voice is astronomer [Fred Hoyle](#). Whereas other physicists and astronomers are very careful not to educate the public to the equivalence between the geocentric and heliocentric systems, Hoyle has been quite candid in providing the necessary information, often to the consternation of his colleagues. In this respect, Hoyle's book, *Nicolaus Copernicus: An Essay on His Life and Work*, although a commemorative effort celebrating the 500th anniversary of the birth of Copernicus, is actually a landmark work revealing in detail the false impression left by the Copernican revolution. As one reviewer noted, Hoyle's book is

...the only brief account, using understandable modern terminology, of what Ptolemy and Copernicus really did. Epicycles are just data analysis (Fourier series), they don't imply any underlying theory of mechanics. Copernicus did not prove that the Earth moves, he made the equivalent of a coordinate transformation and showed that an Earth-centered system and a sun-centered system describe the data with about the same number of epicycles.¹¹⁴⁵

Although in the final analysis Hoyle is a true-blue Copernican (as is the above reviewer), he is not the least bit embarrassed in pointing out the flaws and inadequacies of either the Copernican system or the cosmetic refinements offered by the Keplerian system. In fact, in order to explain the workings of any system, Hoyle frequently resorts to employing geocentric diagrams, since they are, by his own admission, easier to use. In any case, it is the last chapter of Hoyle's book that will be the focus of our analysis, for here, after having shown that there is no kinematical difference between a sun-centered and an Earth-centered system, Hoyle shows the crux of the issue between heliocentrism and geocentrism. He begins:

At the beginning of Chapter I it was stated that we can take either the Earth or the Sun, or any other point for that matter, as the center of the solar system. This is certainly so for the purely kinematical problem of describing the planetary motions. It is also possible to take any point as the center even in dynamics,

¹¹⁴⁵ Physicist J. L. McCauley, Letter on file, 2005.

although a recognition of this freedom of choice had to await the present century. Scientists of the nineteenth century felt the heliocentric theory to be established when they determined the first stellar parallaxes. The positions of the nearby stars were found to undergo annual oscillations, which were taken as reflections of the Earth's annual motion around the Sun. But, kinematically speaking, we can always give to the stars epicyclic motions similar to the ones we found for the planets in Chapter IV. Indeed, if we wish to consider the Earth to be at rest, it will be necessary to give an annual epicyclic motion to every object in the distant universe, as well as to the planets of the solar system. We cannot dismiss such a procedure simply on grounds of inconvenience or absurdity. If our feeling that the Earth really goes around the Sun, not the Sun around the Earth, has any objective validity, there must be some important physical property, expressible in precise mathematical terms, which emerges in the heliocentric picture but not in a geocentric one. What can this property be?¹¹⁴⁶

Thus far, even though he is a heliocentrist by preference who is looking for some proof of his system, Hoyle has been fair with his geocentric counterpart. What other avowed heliocentrists ridicule as “absurd,” Hoyle counts as a viable alternative. In fact, we should add here that many pages earlier Hoyle had already suggested to his reader that one of the reasons the stars may follow an epicyclic pattern is due to what

...was already known to the Greeks that spring-to-summer-to-autumn differs from autumn-to-winter-to-spring by three days. It was explained by Hipparchus.”¹¹⁴⁷

Since, as Hoyle admits, in the geocentric system the universe rotates around the Earth and carries the sun with it, it follows that both the sun and the stars will form an annual epicyclic path with respect to the Earth. As we suggested earlier, the epicycles may exist because there is a designed imbalance in the distribution of matter in the universe that will subsequently cause a precession or wobble in the rotation (much like a spinning gyroscope wobbles when it begins with a tilt; is disturbed while rotating; or has an additional weight at one point on its circumference), which in turn will help produce the periodic movement, which we experience practically on Earth as the four seasons.

In his next section, Hoyle delves deeply into Newton's laws of motion:

¹¹⁴⁶ *Nicolaus Copernicus*, pp. 82-83.

¹¹⁴⁷ *Nicolaus Copernicus*, p. 52.

Consider the well-known Newtonian equation: mass \times acceleration = force. The mass for any particular body is intended to be always the same, independent of where the body is situated or of how it is moving. Suppose we describe the position of a body as a function of time in some given reference frame, and suppose we know the mass. Then, provided we also have explicit knowledge of the force acting on the body, Newton's equation gives us its acceleration. Determining the motion from there on is simply a mathematical problem – in technical terms we have to integrate the above equation. This procedure, which forms the basis of Newtonian mechanics, fails unless we know the force explicitly. In the Newtonian theory of the planetary motions, the theory leading to the basic ellipse from which we worked in Chapter IV, the force is taken to be given by the well-known inverse law: Two masses, m_1 and m_2 , distance r apart, attract each other with a force Gm_1m_2/r^2 where G is a numerical constant. The force is directed along the line joining the bodies.¹¹⁴⁸

Here Hoyle is simply giving his reader a lesson in basic physics, at the same time he is introducing him to the same inadequacies of Newton's laws that we noted previously from Dennis Sciama in previous chapters. As such, Hoyle applies this critique to the crux of the issue:

Now comes the critical question: In what frame of reference is this law considered to operate? In the solar system we cannot consider the inverse-square law to operate *both* in the situation in which the Sun is taken as the center and in that in which the Earth is taken as the center, because Newton's equation would then lead to contradictory results. We should find a planet following a different orbit according to which center we chose, and a body cannot follow two paths (at any rate not in classical physics). It follows that in order to use the inverse-square law in a constructive way we must make a definite choice of center. The situation which now emerges is that to obtain results that agree with observation we must choose the Sun as the center. If the Earth were chosen instead, some law of force other than the inverse-square law would be needed to give motion that agreed with observation.¹¹⁴⁹

Hoyle is reiterating one of the most commonly used arguments to support the heliocentric theory. Based on Newton's inverse-square law, it is ordinarily assumed that a massive body like the sun could not possibly revolve around the tiny Earth. Thus, for the moment, Hoyle seems to be giving credence to the heliocentric theory over the

¹¹⁴⁸ *Nicolaus Copernicus*, pp. 83-84.

¹¹⁴⁹ *Nicolaus Copernicus*, pp. 84-85.

geocentric. In reality, he is only setting up the means by which one will be able to discern the flaws in this traditional thinking. He continues:

Although in the nineteenth century this argument was believed to be a satisfactory justification of the heliocentric theory, one found causes for disquiet if one looked into it a little more carefully. When we seek to improve on the accuracy of calculation by including mutual gravitational interactions between planets, we find – again in order to calculate correctly – that the center of the solar system must be placed at an abstract point known as the “center of mass,” which is displaced quite appreciably from the center of the Sun. And if we imagine a star to pass moderately close to the solar system, in order to calculate the perturbing effect correctly, again using the inverse-square rule, it could be essential to use a “center of mass” which included the star. The “center” in this case would lie even farther away from the center of the Sun. It appears, then, that the “center” to be used for any set of bodies depends on the way in which the local system is considered to be isolated from the universe as a whole. If a new body is added to the set from outside, or if a body is taken away, the “center” changes.¹¹⁵⁰

By this analysis Hoyle has admitted one very important discovery of modern cosmology, that is, the stars affect what occurs in our sun-Earth system. This is not difficult even for a heliocentrist to understand, since in his system the sun is revolving around the Milky Way at a speed of about 500,000 miles per hour (which is about eight times faster than he believes the Earth is revolving around the sun). If the sun must travel so fast in order to equal the Milky Way’s pull toward the center, then it can be safely said that the mass of stars at the core of the galaxy have a great effect on the sun, and in turn, a great effect on the planets going around the sun. Hoyle, for simplicity’s sake, confined his example to “a star...moderately close to the solar system,” but in reality, there are billions of stars in the universe; and each one, however small, has an effect on our sun-Earth system. As such, the stars must be strategically placed in the universe in order to allow the proper balance of forces to be maintained in the sun-Earth system. No doubt this is implied in such Scriptural passages as Psalm 147:4 [146:4]: “He determines the number of the stars, he gives to all of them their names,” or Isaiah 40:26: “Lift up your eyes on high and see who has created these stars. He who brings out their host by number, He calls them all by name; by the greatness of His might, and by the strength of his power, not one is missing.”

We can draw two more points from the foregoing information. First, since the stars produce forces affecting our sun-Earth system, then it would be logical to conclude that the forces we experience in our

¹¹⁵⁰ *Nicolaus Copernicus*, p. 85.

locale are, in part, a product of the conglomeration of stellar forces acting upon us. This means that such things as the inverse-square law, centrifugal force, Coriolis force, and any other force or momentum we calculate on Earth must in part be a result of the forces surrounding us from the universe. As Misner, Thorne and Wheeler have stated it: “Mass there governs inertia here.”¹¹⁵¹ For example, although the inverse-square law is normally understood as being the ratio of the mass to the distance of two or more local objects (e.g., sun and Earth), in reality, the formula Gm_1m_2/r^2 implicitly includes the mass, force, and distance of all the universe’s stars, as well as the objects in the immediate locale under consideration. A simple way to understand this is: if the universe did not have stars, then Gm_1m_2/r^2 would be inaccurate and need to be revised. As Hoyle has noted, even one close star can affect the “center of mass” in our sun-Earth system, thus it is just a matter of understanding the effect of the billions of stars in the universe and applying it to the phenomena of gravity and inertia.

Consequently, modern science is unable to refute the proposition that Gm_1m_2/r^2 is a product of both the local and the non-local systems due to the fact that it is not been able to explain the cause of gravity. Although the components of Gm_1m_2/r^2 appear as if the force of gravity is merely a ratio of mass to distance of the local bodies, since modern science has no explanation for what actually causes gravity and can only tell us that the force increases or decreases depending on mass and distance, it is at a loss to discount the rest of the universe as being an integral part of what causes the increase or decrease of the gravitational force. For example, the two local bodies may merely be disturbances in a sea of gravitational force emanating from the remote regions of the universe that we, in turn, conveniently measure by the formula Gm_1m_2/r^2 , and which modern science, without knowing any differently, attributes only to the interaction between the two bodies in our local system.

Another facet of the principle that Hoyle brings out regarding the “center of mass” (also known as a “barycenter”) and how it is affected by the stars is that, since, as we stipulated, the stars are precisely numbered and strategically placed in the universe (which coincides with the fact that, according to Genesis 1:1-2, the Earth was the first strategically placed object in the universe), then it follows that this precise alignment of the stars would be in a counterbalancing formation against our sun and planets, situated in such a way as to make Earth the immovable barycenter of the universe. Accordingly, such passages as Job 26:9 [26:7]: “He...hangs the Earth upon nothing,” which indicates that the Earth is suspended in space and not supported in any sense by

¹¹⁵¹ *Gravitation*, pp. 543, 546-47, 549. That is, the mass of the stars governs inertia on Earth.

any other celestial body, would be precisely the case if the Earth were the “center of mass” for the universe. If a hole could be dug to the center of the Earth, the above circumstance would be analogous to placing a baseball at the center where it would be suspended weightless and motionless. Yet gyroscopic laws show that any force that attempts to move the barycenter will be resisted by the entire system, and analogously the Earth will resist any force against it with the help of the entire universe. Just as a small gyroscope will keep a huge oil tanker afloat across the ocean without swaying, so the universe in rotation does the same with the center of mass, the Earth.¹¹⁵² Interestingly enough, [Anaximander](#) (d. 547 B.C.) held to the same idea: “The Earth...is held up by nothing, but remains stationary owing to the fact that it is equally distant from all other things.”¹¹⁵³ Perhaps he obtained his view from the Hebrew writers that antedated him by at least a millennium.

The Gyroscopic Effect

Misner, Thorne and Wheeler confirm these mechanical principles from a Relativistic perspective. Acknowledging the gyroscope principle between the Earth and the stars, they write:

Assume that any nongravitational forces acting on the gyroscope are applied at its center of mass, so that there is no torque in its proper reference frame. Then the gyroscope will ‘Fermi-Walker transport’ its spin along its world line...The spin is a purely spatial vector in this comoving frame; its length remains fixed (conservation of angular momentum); and its direction is regulated by the Fermi-Walker transport law. The basis vectors of the comoving frame are not Fermi-Walker transported, by contrast with the spin. Rather, they are tied by a pure boost (no rotation!) To the PPN [Parametrized Post-Newtonian, p. 1069] coordinate grid, which in turn is tied to an inertial frame far from the solar system, which in turn one expects to be fixed relative to the ‘distant stars.’ Thus, by calculating the precession of the spin relative to the comoving frame, one is in effect evaluation the spin’s angular velocity of

¹¹⁵² Charles W. Misner, Kip S. Thorne and John A. Wheeler, *Gravitation*, New York: W. H. Freeman, 1973, pp. 1117-1119. Misner, et al, already stated much earlier in their book that the CMB had the precise form and intensity expected if Earth were the centerpiece of a blackbody cavity (*Gravitation*, pp. 764-797). The logical conclusion should have been that the Earth *is in the center* of the universe and the universe is closed.

¹¹⁵³ As obtained from Aristotle’s *De Caelo*, 295b32, cited in Popper’s *Conjectures and Refutations*, p. 138. Anaximander, however, understood the Earth to be in the shape of a drum rather than a globe.

precession, relative to a frame fixed on the sky by the distant stars.¹¹⁵⁴

The gyroscopic effect that keeps Earth, the center of mass, in a non-moveable position in the universe also prohibits the Earth from rotating in that preferred position. As [Martin Selbrede](#) explains it:

It is often objected that if geocentricity were true, and the rotating heavens were dragging Foucault pendula and weather systems around, why doesn't that force pull on the Earth itself and drag it along, causing it to eventually rotate in sync with the heavens? It appears that this straightforward application of torque to the Earth should cause it to rotate in turn, but this turns out to be an oversimplification. As the heavens rotate, and the firmament rotates on an axis through the Earth's poles, each firmament particle...also rotates with the same angular velocity. Ironically, this is precisely the reason the Earth can't be moved.¹¹⁵⁵

Selbrede goes on to explain the validity of above proposition by appealing to an illustration of the same principle crafted by L. I. Schiff and reintroduced by Misner, Thorne and Wheeler. The authors state:

The gyroscope is rotationally at rest relative to the inertial frames in its neighborhood. It and the local inertial frames rotate relative to the distant galaxies with the angular velocity Ω because the Earth's rotation "drags" the local inertial frames along with it. Notice that near the north and south poles the local inertial frames rotate in the same direction as the Earth does (Ω parallel to J), but near the equator they rotate in the opposite direction (Ω antiparallel to J ; compare Ω with the magnetic field of the Earth!).¹¹⁵⁶

Misner, *et al.*, then offer an analogy that explains the above relationship, although they are careful in a footnote to say that, despite it

¹¹⁵⁴ Charles W. Misner, Kip S. Thorne and John A. Wheeler, *Gravitation*, New York: W. H. Freeman, 1973, pp. 1117-1119. Misner, et al, already stated much earlier in their book that the CMB had the precise form and intensity expected if Earth were the centerpiece of a blackbody cavity (*Gravitation*, pp. 764-797). The logical conclusion should have been that the Earth *is in the center* of the universe and the universe is closed.

¹¹⁵⁵ Martin Selbrede, "Geocentricity's Critics Refuse to Do Their Homework," *The Chalcedon Report*, 1994, p. 11. In this 12-page rebuttal of Michael Martin Nieto of Los Alamos National Laboratory, who was hired by Gary North (a Reconstructionist-Theonomist), to attempt to refute geocentrism, Selbrede has written one of the best defenses of geocentrism, using the very principles of Relativity theory.

¹¹⁵⁶ The formula to which Misner, *et al.* refer is stated on the same page (1119), which is: $\Omega = -\frac{1}{2} \Lambda \times \mathbf{g} = (7/8\Delta_1 + 1/8\Delta_2) 1/r^3 [-J + 3(J \times r)]/r^2$.

being only an analogy, “This analogy can be made mathematically rigorous,” and thus they proceed with the illustration:

Consider a rotating, solid sphere immersed in a viscous fluid. As it rotates, the sphere will drag the fluid along with it. At various points in the fluid, set down little rods, and watch how the fluid rotates them as it flows past. Near the poles the fluid will clearly rotate the rods in the same direction as the star [i.e., sphere] rotates. But near the equator, because the fluid is dragged more rapidly at small radii than at large, the end of a rod closest to the sphere is dragged by the fluid more rapidly than the far end of the rod. Consequently, the rod rotates in the direction opposite to the rotation of the sphere.¹¹⁵⁷

Following the analogy to its logical conclusion, Selbrede then comments how it confirms the geocentric model:

Now reverse the situation. If we want to cause the sphere to rotate clockwise, we would need to turn the rods at the poles clockwise, and the ones at the equators counterclockwise....This picture is clear then: to turn the sphere, the rotation of the particles (MTW’s “rods”) at the poles must be the opposite of that at the equator...However, in the case of a rotating firmament, all the particles are rotating in the same direction, with the angular velocity common to the entire firmament. The equatorial inertial drag is in the opposite direction as the acting near the poles. Using calculus, one integrates the effect from the center of the Earth outward in infinitesimal shells, showing that the Earth is in fact locked in place, the resulting inertial shear being distributed throughout the Earth’s internal volume. It could be demonstrated that were the Earth to be pushed out of its “station keeping” position, the uneven force distribution would return it to its equilibrium state.¹¹⁵⁸ [([First Image](#)) ([Second Image](#)) ([Third Image](#))].

It would certainly require an infinite mind to see everything at once and calculate all the interacting forces so that every object could be placed in its proper position in the universe. Modern science certainly can raise no objection to the possibility of such a universe, for its very

¹¹⁵⁷ Misner, Thorne and Wheeler, *Gravitation*, p. 1120. When the authors say “the fluid is dragged more rapidly at small radii than at large,” they are referring to a rod positioned perpendicular to the tangent of the sphere, wherein the part of the rod closest to the sphere’s tangent is the “small radii” while that farther away is the large radii.

¹¹⁵⁸ Martin Selbrede, “Geocentricity’s Critics Refuse to Do Their Homework,” *The Chalcedon Report*, 1994, pp. 11-12. Selbrede has supplied us with diagrams to illustrate the Geo-lock phenomenon. Observer pictorials in sequence: ([First Image](#)) ([Second Image](#)) ([Third Image](#)).

laws give it sanction. In fact, as photographs of the universe show, there may be a good reason why the distribution of stars in some places of the universe is not isotropic, that is, various sections of the universe contain no stars, and other parts contain huge clumps of stars. These variations are not accidental but are the precise distribution patterns required in order to maintain the forces that keep Earth as the barycenter in the midst of a sun and planets that are whirling about its equatorial plane.

Hoyle proceeds in his argumentation:

A similar circumstance was already present throughout our calculations, when we regarded angles as being measured with respect to a “fixed direction,” it being implied that distant stars had directions that were “fixed” in this sense. If we make a calculation, using both Newton’s equation and the inverse-square law, but measuring angles with respect to a direction that rotates with respect to the distant universe, things go very wrong. Newton was fully aware that his system of dynamics would work correctly only provided the “fixed directions” in the theory were chosen in a suitable way. His reference to the well-known rotating-bucket experiment was intended to illustrate this point.¹¹⁵⁹

Here Hoyle merely touches upon a subject that we covered at great length in previous chapters – Newton’s rotating-bucket of water. We discovered that the water in the bucket shows that there is an outside force causing the water to climb the inside walls of the bucket. Newton’s explanation was that the water was curving upward in relation to absolute space, and that rotation was the unique movement that caused it, which we label today as “centrifugal force.” But Newton, by his own admission, did not know the physical reason why a rotating object had such an outward force. It is good to remember that Newton did not have an explanation for the causes of all the forces for which he has become famous (gravity, inertia, centrifugal force). He merely had a knack for figuring out the mathematical relationship among these mysterious forces.

As we noted, [Ernst Mach](#) and [Albert Einstein](#) proposed their own gravitational theories in order to explain the water-bucket phenomenon. Mach insisted that the water curved upward because it was reacting to the gravity from the mass of distant stars surrounding it. Einstein had a similar answer, except that he attempted to make the gravitational force of the stars combine with the local force of space-time, but in essence, the stars remain a vital force in the bending of the surface of the water. In any case, Hoyle’s reference to Newton’s water-bucket shows that he knows there is more to this cosmological puzzle than meets the eye, and that the conventional means of supporting the

¹¹⁵⁹ *Nicolaus Copernicus*, pp. 85-86.

heliocentric theory (*viz.*, by the inverse-square law) is simply not going to pass muster. Hoyle continues:

It is clear therefore that in order to define the appropriate “center” of the local system in a useful way, and in order to define “fixed directions” relative to which angles are to be measured, we must take account of the relation of the local system to the universe outside. It seems that the local laws of force take simple forms only when the center is unaccelerated with respect to a frame of reference determined by the universe in the large, and when the fixed directions do not rotate with respect to the distant universe. From this point of view we can compare the heliocentric and geocentric theories of the solar system in an unequivocal way. We ask: Is it the Sun that is accelerated with respect to the universe, or is it the Earth?¹¹⁶⁰

Thus, having admitted that he cannot speak of a “center” unless he includes the universe at large, nevertheless, Hoyle is now pressing for the option of applying a local frame of reference, since that will be the only way to give preference to choosing the Earth as the accelerating body rather than the sun. As such, Hoyle answers his own question:

Neglecting small effects, the answer is that the Earth is accelerated, not the Sun. Hence we must use the heliocentric theory if we wish to take advantage of simple rules for the local forces.¹¹⁶¹

In other words, in order to give legitimacy to the heliocentric system, Hoyle must resort, even against his clear admissions concerning the force of the entire universe, to limiting his analysis to the local system of the sun and Earth. By eliminating the stars, Hoyle can then claim that the inverse-square law is merely a local phenomenon, and thus demand that the smaller body (Earth) accelerate against the larger body (the sun), rather than vice-versa. Unfortunately, this is the problem with most of modern cosmology. Although on the one hand they admit to the powerful force of the stars due to the fact that the sun is said to revolve around its own galaxy, in addition to the fact that the Milky Way is said to revolve around other clusters of galaxies at an even faster speed than the sun, yet when support is required for the heliocentric system, modern cosmology conveniently removes the stars and galaxies from the grand scheme of things in order to be left with mere “local” forces in order to have the Earth accelerating with respect to the sun.

¹¹⁶⁰ *Nicolaus Copernicus*, p. 86.

¹¹⁶¹ *Nicolaus Copernicus*, p. 86.

Being the honest astronomer and physicist he is, however, Hoyle still leaves room for his geocentric opponent, saying, “But this is not to say that we cannot use the geocentric theory if we are willing to use more complex rules for the forces.”¹¹⁶² By “complex...forces” Hoyle is referring to the force of the billions of stars in the universe, forces which it would be very difficult for him to calculate but that he knows implicitly affect our local system. Amazingly, Hoyle admits that, if the “complex force” and “fixed directions” are followed step-by-step until their logical end, the barycenter of the universe will drift further away from the sun and closer to the Earth. Newton tried to stop this drift by propping up his “absolute space,” but since that is merely a convenient invention, Hoyle recognizes that this only leaves the stars and the rest of the universe to define the barycenter. Thus, not only has Hoyle admitted to the viability of the geocentric system based on the equivalence of the geocentric and heliocentric “kinematics,” he has now given full credence to the geocentric system by admitting that alternative measurements of forces can be used to show how the geocentric system functions.

Hoyle is not done yet. He admits further weaknesses in modern science’s ability to settle upon heliocentrism as the preferred model.

The present discussion has been formulated from the standpoint of the Newtonian theory, which is not well suited to problems concerning the universe in the large. We might hope therefore that the Einstein theory, which is well suited to such problems, would throw more light on the matter. But instead of adding further support to the heliocentric picture of the planetary motions, the Einstein theory goes in the opposite direction, giving increased respectability to the geocentric picture. The relation of the two pictures is reduced to a mere coordinate transformation, and it is the main tenet of the Einstein theory that any two ways of looking at the world which are related to each other by a coordinate transformation are entirely equivalent from a physical point of view. Moreover, in the Einstein theory the method of calculating the effect of gravitation is changed to a form which applies equally to all such related ways of expressing a problem.¹¹⁶³

As we noted in earlier chapters dealing with Einstein, it is quite ironic when we consider that Einstein’s theory was formulated for the express purpose of relativizing nature so that no one could lay claim to a motionless Earth, yet it is the theory of Relativity that forces science to come full circle and admit that a motionless Earth in the center of the universe is just as physically and mathematically viable as a moving

¹¹⁶² *Nicolaus Copernicus*, pp. 86-87.

¹¹⁶³ *Nicolaus Copernicus*, p. 87.

Earth in a fixed universe. In the face of this, Hoyle tries one last ditch effort to save face for heliocentrism:

It may still happen that it is easier to work through the details of a particular problem with respect to one coordinate system rather than to another, but no special physical merit is to be adduced from such a circumstance. Indeed, from a mathematical point of view, the problem of the planetary motions certainly continues to be easier to grapple with in the heliocentric picture. The simplification of such a picture shows itself in the Einstein theory through boundary conditions which are impressed on the space-time structure at a large distance from the Sun – which is to say in terms of the control imposed by the universe in the large.¹¹⁶⁴

As we see, although Hoyle proposes that heliocentrism is easier to use on a mathematical basis, nevertheless, he reinforces the fact that nothing in the heliocentric system provides it a “special physical merit.” In other words, there is no physical basis for preferring heliocentrism over geocentrism, let alone any proof for it; rather, there is merely the option of representing the heliocentric system by a less laborious mathematical analysis. Even that point is a matter of opinion, since the “mathematics” to which Hoyle is referring is “Einstein’s theory through boundary conditions...imposed by the universe at large.” This is Einstein’s attempt, through the use of geodesics and tensor calculus, to meld the local reference frame with the universe’s reference frame. Einstein used this same melding of local and universal forces in order to explain Newton’s water-bucket phenomenon.

In regard to the question of complexity, it would do well to remember the words of Sir Arthur Eddington when posed with the question of who in the world understood Einstein’s mathematics. In November 1919, Ludwik Silberstein approached Eddington at a joint meeting of the Royal Society and the Royal Astronomical Society. “Professor Eddington,” Silberstein declared, “you must be one of three persons in the world who understands general relativity.” When Eddington was silent, Silberstein continued: “Don’t be modest, Eddington.” “On the contrary,” Eddington replied. “I am trying to think who the third person is!”¹¹⁶⁵ This reply, of course, was the perfect ploy to form a mystique around Relativity. If one judged Relativity as bogus, then it could be retorted that he was “not one of three who understood it.” If one showed favor to Relativity, he would be deemed as “smart” as the original three.

¹¹⁶⁴ *Nicolaus Copernicus*, pp. 87-88.

¹¹⁶⁵ *Time*, February 19, 1979, p. 76; *Einstein: The Life and Times*.

Hoyle makes his final admission in the last paragraph of the book:

So we come back full circle to what was said at the beginning of this book. Today we cannot say that the Copernican theory is “right” and the Ptolemaic theory “wrong” in any meaningful physical sense. The two theories, when improved by adding terms involving the square and higher powers of the eccentricities of the planetary orbits, are physically equivalent to one another. What we can say, however, is that we would hardly have come to recognize that this is so if scientists over four centuries or more had not elected to follow the Copernican point of view. The Ptolemaic system would have proved sterile because progress would have proven too difficult.¹¹⁶⁶

In other words, the one thing that the venture into Copernicanism accomplished is to reinforce the viability of the Ptolemaic system. In effect, Hoyle has shown us that the battle between heliocentrism and geocentrism, at least with an emphasis on daily motions, is one fought between adopting a purely local system as opposed to a non-local or universal system. As we have seen throughout this volume, there is no escape from the latter. Although it is often camouflaged under different names, modern physics has not only accepted that motion can only properly be explained by reference to the non-local system, Quantum Mechanics has disavowed itself almost entirely from the local system prescribed by Relativity theory.¹¹⁶⁷

¹¹⁶⁶ *Nicolaus Copernicus*, p. 88.

¹¹⁶⁷ As Misner, Thorne and Wheeler state: “The uncertainty principle thus deprives one of any way whatsoever to predict, or even to give meaning to, ‘the deterministic classical history of space evolving in time.’ *No prediction of spacetime, therefore no meaning for spacetime*, is the verdict of the quantum principle. That object which is central to all of classical general relativity, the four-dimensional spacetime geometry, simply does not exist, except in classical approximation” (*Gravitation*, pp. 1182-3, emphasis theirs).

Einstein's Geocentrism

Still, if one were to insist upon a Relativistic explanation of forces, it is, ironically, Relativity that lends the greatest support to a geocentric universe. For example, in a June 25, 1913, letter to Ernst Mach, Einstein writes the following:

[Y]our happy investigations on the foundations of mechanics, Planck's unjustified criticism notwithstanding, will receive brilliant confirmation. For it necessarily turns out that inertia originates in a kind of interaction between bodies, quite in the sense of your considerations on Newton's pail experiment. The first consequence is on p. 6 of my paper. The following additional points emerge: (1) If one accelerates a heavy shell of matter S, then a mass enclosed by that shell experiences an accelerative force. (2) If one rotates the shell relative to the fixed stars about an axis going through its center, a Coriolis force arises in the interior of the shell, that is, the plane of a Foucault pendulum is dragged around.¹¹⁶⁸

¹¹⁶⁸ A series of four letters compiled by Friedrich Herneck in "Zum Briefwechsel Albert Einsteins mit Ernst Mach," *Forschungen und Fortschritte*, 37:239-43, 1963. The original letter was released from the estate of Albert Einstein by the executors Helen Dukas and Otto Nathan. Copy of the original letter is reproduced in Misner, Thorne and Wheeler's *Gravitation*, pp. 544-545. Other sources verify Einstein's mathematical analysis. In 1978, **Lawrence P. Orwig** of the University of Wisconsin discovered that: "The interior field of a thin mass shell or arbitrary momentum per unit mass a ... in a parameter ($V^2 = 1 - 2m/R + a^2/R^2$) which measures the nearness of the shell to its gravitational radius.... Shell shape is arbitrary beyond the requirement of sphericity in the limits of $a > 0$ or $V > 0$. It is shown that as $V > 0$, the interior inertial frames are dragged around rigidly at the same rate as the shell, for all a " (Lawrence P. Orwig, "Machian Effect in Compact, Rapidly Spinning Shells," *Physical Review D*, 1757-1763, 1978, abstract). **Oyvind Grøn and E. Eriksen** say much the same. Citing Orwig's previous work, they write: "It was found that in the limit of a spherical shell with a radius equal to its Schwarzschild radius, the interior inertial frames are dragged around rigidly with the same angular velocity as that of the shell. In this case of 'perfect dragging' the motion of the inertial frames is completely determined by the shell" ("Translational Inertial Dragging," *General Relativity and Gravitation*, Vol. 21, No. 2, 1989, pp. 109-110. My thanks to Martin Selbrede for these sources and analysis). To show how General Relativity posits no barriers to geocentrism, Grøn and Eriksen provide an incontestable example of its application: "As an illustration of the role of inertial dragging for the validity of the strong principle of relativity, we consider the Moon orbiting the Earth. As seen by an observer on the Moon both the Moon and the Earth are at rest. If the observer solves Einstein's field equations for the vacuum space-time outside the Earth, he might come up with the Schwarzschild solution and conclude that the Moon should fall toward the Earth, which it does not. So it seems impossible to consider the Moon as at rest, which would imply that the strong principle of relativity is not valid. This problem has the following solution. As observed from the Moon the cosmic mass rotates. The rotating cosmic mass has to be included when the Moon observer solves Einstein's field equations. Doing this he finds that the rotating cosmic mass induces the rotational nontidal gravitational field which is interpreted as the centrifugal field in Newtonian theory. This field explains to him why the Moon does

Although Einstein is supposing that the stars are “fixed” and that the Earth rotates, according to Relativity theory the above paragraph can just as easily be applied to a rotating star-system (the universe) around a fixed Earth. In such a case, the universe would be the “heavy shell of matter S,” which, as it rotates, will create “an accelerative force” on the “mass enclosed by that shell,” the “mass” being any heavenly body. The “accelerative force” is understood by Einstein to be the “Coriolis force,” which is the force commonly cited to explain why “a Foucault pendulum” rotates. In other words, a universe of stars rotating around a fixed Earth will cause the peculiar movement of the Foucault pendulum just as a rotating Earth in a “fixed star” system. Like a leaf in a whirlpool, the pendulum would be carried around and around. It has inertia because it is caught in the gravitational draft of the stars’ diurnal circular movement. In fact, under the heading “dragging of inertial frames,” Misner, Thorne and Wheeler posit that the angular velocity of the Foucault pendulum would be equal to that of the rotation of the stars. They write:

Consider a bit of solid ground near the geographic pole, and a support erected there, and from it hanging a pendulum. Though the sky is cloudy, the observer watches the track of the Foucault pendulum as it slowly turns through 360°. Then the sky clears and, miracle of miracles, the pendulum is found to be swinging all the time on an arc fixed relative to the far-away stars. If “mass there governs inertia here,” as envisaged by Mach, how can this be?

Enlarge the question. By the democratic principle that equal masses are created equal, the mass of the Earth must come into the bookkeeping of the Foucault pendulum. Its plane of rotation must be dragged around with a slight angular velocity, ω_{drag} , relative to the so-called “fixed stars”....The distant stars must influence the natural plane of vibration of the Foucault pendulum as the nearby rotating shell of matter does, provided

not fall” (“Translational Inertial Dragging,” *General Relativity and Gravitation*, Vol. 21, No. 2, 1989, pp. 117-118). Regarding the feasibility of a rotating universe, **Yu. N. Obukov** found that there are no adverse effects: “...the analysis of its relation to Mach’s principle...there is a general belief that rotation of the universe is always a source of many undesirable consequences, most serious of which are timelike closed curves, parallax effects, and anisotropy of the microwave background radiation. The aim of this paper is...to show that the above phenomena are not inevitable (and in fact, are not caused by rotation)...As we see, pure rotation can be, in principle, large, contrary to the wide-spread prejudice that large vorticity confronts many crucial observations. In particular, the most popular claim that vorticity causes anisotropy of the microwave background radiation is apparently wrong...It is shear, not rotation, which is the true (and only) source of anisotropy of the background radiation” (“Rotation in Cosmology,” *General Relativity and Gravitation*, Vol. 24, No. 2, 1992, pp. 121, 123-124).

that the stars are not so far away...that the curvature of space begins to introduce substantial corrections into the calculation of Thirring and Lense. In other words, no reason is apparent why all masses should not be treated on the same footing...Mach's idea that mass there determines inertia here has its complete mathematical account in Einstein's geometrodynamical law." Point out, please," the anti-Machian critic says, "the masses responsible for this inertia." In answer, recall that Einstein's theory includes not only the geometrodynamical law, but also, in Einstein's view, the boundary condition that the universe be closed...This mass-energy, real or effective, is to be viewed as responsible for the inertial properties of the test particle that at first sight looked all alone in the universe.¹¹⁶⁹

It would be no surprise to find the same reasoning in Einstein's thinking. I will interject explanations in brackets so the reader can follow Einstein's flow of thought in concrete terms:

Let K [the universe] be a Galilean-Newtonian coordinate system [a system of three dimensions extending to the edge of the universe], and let K' [the Earth] be a coordinate system rotating uniformly relative to K [the universe]. Then centrifugal forces would be in effect for masses at rest in the K' coordinate system [the Earth], while no such forces would be present for objects at rest in K [the universe]. Already Newton viewed this as proof that the rotation of K' [the Earth] had to be considered as "absolute," and that K' [the Earth] could not then be treated as the "resting" frame of K [the universe]. Yet, as E. Mach has shown, this argument is not sound. One need not view the existence of such centrifugal forces as originating from the motion of K' [the Earth]; one could just as well account for them as resulting from the average rotational effect of distant, detectable masses as evidenced in the vicinity of K' [the Earth], whereby K' [the Earth] is treated as being at rest. If Newtonian mechanics disallow such a view, then this could very well be the foundation for the defects of that theory...¹¹⁷⁰

¹¹⁶⁹ Misner, Thorne and Wheeler, *Gravitation*, pp. 547-549. NB: the authors cite the work of Thirring and Lense work of 1918 and 1921 (which Einstein also cited in his book *The Meaning of Relativity*).

¹¹⁷⁰ Hans Thirring, "Über die Wirkung rotierender ferner Massen in der Einsteinschen Gravitationstheorie," *Physikalische Zeitschrift* 19, 33, 1918, translated: "On the Effect of Rotating Distant Masses in Einstein's Theory of Gravitation." Three years later, Thirring made a correction and wrote the essay: "Berichtigung zu meiner Arbeit: 'Über die Wirkung rotierender ferner Massen in der Einsteinschen Gravitationstheorie,'" *Physikalische Zeitschrift* 22, 29 (1921), translated: "Correction to my paper 'On the Effect of Rotating Distant Masses in Einstein's Theory of Gravitation.'"

In other words, Einstein has confirmed that a universe in rotation around the Earth would produce the same centrifugal and Coriolis forces attributed to a rotating Earth in a fixed universe. In essence, what Einstein attempted to take away with Special Relativity (to avoid the intractable problems precipitated by the Michelson-Morley experiment), he must now give back with General Relativity and admit that his entire scheme leads inevitably back to the “unthinkable” position that the Earth is immobile in the center of the universe.

Thirring's Geocentrism

Adding to the discussion, Misner, *et al.*, make reference to the work of [Hans Thirring](#) as offering support for their conclusions. In his 1918 paper, Thirring examined the motion of rotating bodies. His purpose was to determine how the universe, if it were a rotating shell, would affect movement on Earth (e.g., Foucault pendulums, wind currents, weather satellites, etc), and inadvertently, it provided Thirring with a mathematical model for a geocentric universe. Thirring found that objects would move as we normally see them move, but with an additional force pulling away from the center and thus opposite the pull of gravity. After five pages of tensor calculus, Thirring makes some preliminary conclusions, but with a new discovery. He writes:

As one can see, the first terms of the X and Y components correspond to the Coriolis force, and the second terms correspond to the centrifugal force. The third equation yields the surprising result that the centrifugal force possesses an axial component.¹¹⁷¹

The “axial component” is the force that pulls toward the equator and is in addition to the radial or outward force we normally associate with centrifugal force. (As we note below, it is the axial component that is now being associated with the recent discovery of “frame-dragging”). Thirring explains this “new” component as follows:

As seen by an observer-at-rest, those surface elements of the hollow sphere which are nearest the equator have a greater velocity, and hence also a greater apparent (inertial and gravitational) mass than those about the poles. The field of a rotating hollow sphere of uniform surface density is therefore conformable to the field of a spherical shell at rest for which the surface density increases with increasing polar angle, θ . That is, points away from the equatorial plane are drawn towards the equatorial plane.¹¹⁷²

In other words, being a believer in Relativity and preferring Copernicanism, Thirring attempts to explain the pull toward the Earth's equator by saying that objects near the equator attain more mass than objects at the poles since the former are moving faster, i.e., 1054 mph in Earth's rotation as opposed to practically zero rotation at the poles.

¹¹⁷¹ *Ibid.*, p. 37.

¹¹⁷² *Ibid.*, p. 37. Thirring adds: “We also note in passing that it is easy to visualize that in the interior of such a hollow sphere of unequal surface density, forces appear analogous to the centrifugal forces.”

Relativity proposes that objects in motion have more mass than immobile objects, thus, it is the “extra mass” in motion that is creating the axial centrifugal force.

Moreover, letting Relativity do its work, Thirring says that the above situation would be the same if the Earth were fixed and the surrounding rotating shell (i.e., the universe) had the equatorial part of its shell possess a greater thickness than its poles. This is quite an inviting proposal to a geocentrist since it provides not only the cosmological origin of the axial component, but also a component for the origin of the force necessary for the universe to precess, or wobble, as it turns, thus creating the seasons and many of the other precessional phenomena we observe in the sky. The reason the tilt never accrues to more than 23.5 degrees is that the axial force keeps bringing the universe back to the equatorial plane, all such motion pivoting on the barycenter, the Earth.

As in all gyroscopes, the center of mass does not move, and thus the universe can rotate and precess without ever disturbing the Earth. This is so since all such forces, whether gravitational, centrifugal, or Coriolis, will act on the very center of the mass (in this instance, the very center of the Earth). As Newton himself noted about gravity, it is as if all the gravitational force is directed to the very center of the Earth. Anything that is materially and solidly attached to the center (as is the rest of the radius of the Earth) will likewise take part in the forces directed at the very center. Any temporary detachment, such as a shifting of the mantle from the core, may reveal itself in some kind of cataclysm at the surface (earthquake, volcano).

Accordingly, Thirring goes on to state: “Finally, from equation 25 we can see that if body and sphere rotate in the same sense, then there results a reduction in the centrifugal and Coriolis forces.”¹¹⁷³ That is, if both the universe and the Earth were rotating, the centrifugal and Coriolis forces would be less than they are presently. At first, Thirring thought he might have an error in his calculations, but as it turned out, the forces had the same magnitude as centrifugal and Coriolis forces (the same forces that Einstein spoke about as occurring in his rotating “heavy shell of matter”). As Thirring notes in his concluding remark:

By means of a concrete example it has been shown that in an Einsteinian gravitational field, caused by distant rotating masses, forces appear which are analogous to the centrifugal and Coriolis forces.

Thus Thirring found what had eluded heliocentric mechanics since the time of Newton, that is, a physical explanation for centrifugal and Coriolis forces. The reason for this is obvious: Thirring included the mass of the universe in his calculations, whereas heliocentric mechanics limits itself to explaining force and movement to masses in the local

¹¹⁷³ *Ibid.* p. 39.

system. In any case, Thirring discovered that centrifugal and Coriolis forces are caused by the forces in the universe, and thus they are outward gravitational forces. When a ball is swung on a rope, the reason the ball moves outward is that it is being attracted by the gravity of all the objects in the universe. (Heliocentric mechanics has no physical explanation for the ball's outward tug on the string). The very act of rotation introduces us to the connection between the ball and the stars. Similarly, the reason a Foucault pendulum forms a parabola is not necessarily because the Earth underneath is rotating, but because the forces from the cosmos are dragging the free-moving pendulum. As such, Misner's, *et al.*, appeal to Relativistic "frame dragging" to explain a particular motion is discounted in favor of a real and physical frame-dragging – that of the pendulum "frame" itself moved by the force of the cosmos against the fixed "frame" of Earth.

Recently NASA's Joint Center for Earth Systems Technology headed by Erricos Pavlis, along with Ignazio Ciufolini of the University of Lecce, made claims of confirming Einstein's General Relativity by measuring the long-awaited Lense-Thirring effect. The effect shows itself as a "precession of the satellite's node on the equatorial plane," and is said to be caused by the

Earth's rotation...which curves space-time in its vicinity...creating 'mass' currents, in analogy to magnetic currents in electrodynamics....Our new result agrees with the GR theory to $99\% \pm 5\%$.¹¹⁷⁴

These results, however, do not prove either General Relativity or heliocentrism. In fact, as noted above, Thirring's original 1918 model theorized the universe as a rotating shell around a fixed-Earth as opposed to a rotating Earth in a fixed-universe. Thirring realized that in Einstein's theory "the required equivalence appears to be guaranteed by the general covariance of the field equations,"¹¹⁷⁵ and thus any claims that the additional force discovered by Thirring is proof of a rotating Earth is simply ignoring the very foundation of both Einstein's and Thirring's work. In any case, Thirring's tensor calculus revealed that there was an additional gravitational field caused by the rotation of the shell, although small enough that it had not been detected until the work of Pavlis and Ciufolini.

[Joseph Lense](#) joined Thirring and made more calculations, this time replacing the rotating shell by a rotating solid sphere, and still the

¹¹⁷⁴ Ben Chao, NASA Space Geodesy Branch, Code 926, Goddard Space Flight, Nov. 1, 2004. I. Ciufolini, E. C. Pavlis. "A Confirmation of the General Relativistic Prediction of the Lense-Thirring Effect," *Nature*, 431, 958-60, October 21, 2004.

¹¹⁷⁵ Thirring, p. 33.

same forces appeared.¹¹⁷⁶ The importance of the discovery is accentuated by the fact that Newtonian mechanics did not incorporate such a force. Consequently, since proponents of General Relativity understand Einstein's theory as filling in the gaps of Newtonian mechanics, it is natural for them to seek an explanation of the Lense-Thirring effect by recourse to Einstein's concept of "frame-dragging," thus positing that the supposedly rotating Earth was "dragging" part of the space-time continuum and thus producing a small force, which was then turned into "proof" of General Relativity. In reality, however, the Lense-Thirring effect proved only that the movement of the surrounding object against its center creates a small force. Again, since Lense-Thirring found that the force created by the rotating object was directed away from the center, and thus opposite the pull of gravity, the larger forces would be analogous to the centrifugal and Coriolis forces that have long been without a mechanical explanation in Newtonian mechanics, and an explanation that General Relativity had to borrow from Machian mechanics, saving face for the theory by mathematically creating the presence of "gravitational potentials" which supplied the forces that pulled away from the center of the object in view.

Interestingly enough, these results also coincide with the Michelson-Morley experiment and the remaining interferometer experiments up to Joos in 1932. Each of the interferometers found a small positive result, coinciding with an ether drift of about 4 km/sec. If this can be attributed to the rotation of the universe wherein the 4 km/sec is the residual drift of that which is much greater at the rim of the universe, we have the substance of the mechanical properties needed to transport the required forces. In other words, the rim of the universe (which is analogous to the "shell" in Lense-Thirring terminology) are the layers above the firmament which, in rotation, cause the centrifugal and Coriolis forces felt on Earth, and which is then transported from the rim to the Earth by the ether, detected in all interferometer experiments. Not knowing any better, Thirring tries to explain the previous undetectability of the centrifugal axial component by saying:

¹¹⁷⁶ Joseph Lense and Hans Thirring, "Über den Einfluss der Eigenrotation der Zentralkörper auf die Bewegung der Planeten und Monde nach der Einsteinschen Gravitationstheorie," *Physikalische Zeitschrift* 19, 156-163 (1918), translated: "On the Influence of the Proper Rotation of Central Bodies on the Motions of Planets and Moons According to Einstein's Theory of Gravitation." They write: "...the rotation of distant masses produces a gravitational field equivalent to a centrifugal field. From another perspective it seems interesting now, by the same means, to perform the not too difficult task of integrating the field equations for a rotating solid sphere. In the Newtonian theory one can exactly replace the field in the space surrounding a (stationary or rotating) sphere of incomprehensible fluid as equivalent to that of a point mass; but for a rotating sphere this is not the case. In the latter case...there appear supplementary terms corresponding to centrifugal and Coriolis forces" (p. 156).

The fact that in nature we only have been able to observe a radial, but never an axial component of the centrifugal force can be brought into agreement with the results obtained here by noting that the approximation of the heaven of fixed stars by means of an infinitesimally thin hollow sphere is certainly not physical.¹¹⁷⁷

We maintain, however, that the “hollow sphere” is physical, and thus the recent discovery of the frame-dragging effect has a physical cause, not a “space-time” cause. The tremendous centrifugal forces created by the rotating universe are the forces that counterbalance the force of gravity. The centrifugal force is the weakest near the Earth and the strongest near the rim of the universe. Since gravity on Earth is not overcome by the centrifugal force, objects can cling to the Earth. But if an object on Earth reaches a certain speed (which we know as “escape velocity”), then it joins the centrifugal force. As such, the sun and planets are positioned around the Earth in the precise location so that the centrifugal forces balance the gravitational force and thus all the bodies remain in their balanced positions, and the balance is felt as inertia.

Lense and Thirring are not the only modern physicists and mathematicians to posit the plausibility of a fixed-Earth within a rotating universe. Granted, none of these scientists introduce their findings by stating they have accepted geocentrism as a scientific fact; rather, they affirm they have accepted the scientific principle that the same forces claimed for a heliocentric model can be applied equally well to a geocentric universe.

¹¹⁷⁷ *Ibid.*, p. 38.

Rosser's Geocentrism

The “unthinkable” geocentric universe is true not only in principle since, even in more practical ways, General Relativity supports geocentrism often better than geocentrism supports itself. For example, although we touched upon this issue in Chapter 1 by way of introduction, one of the main objections from novices introduced to the idea of an immobile Earth in the center of the universe is that it would be impossible for the stars to revolve around the Earth at such tremendous speeds, speeds thousands of times faster than the speed of light. The common objection, which is based on Einstein's postulate, is: “Nothing can go faster than the speed of light.” The answer to this objection often comes as a shock, but it is a fact nonetheless. First, according to Einstein's very own Relativity theory, the objection would only apply to Special Relativity, in the absence of a gravitational field. According to Einstein's more advanced General Relativity theory, anything can go faster than the speed of light (a fact not often admitted by Relativists with a bias toward shutting out alternative models). Earlier we cited William G. V. Rosser addressing this concept, and it is worth repeating, since so many people are misinformed about what Relativity allows and disallows:

Relative to the stationary roundabout [the Earth], the distant stars would have a velocity $r\omega$ [radius x angular velocity] and for sufficiently large values of r , the stars would be moving relative to O' [the observer] with linear velocities exceeding 3×10^8 m/sec, the terrestrial value of the velocity of light. At first sight this appears to be a contradiction...that the velocities of all material bodies must be less than c [the speed of light]. However, the restriction $u < c = 3 \times 10^8$ m/sec is restricted to the theory of Special Relativity. According to the General theory, it is possible to choose local reference frames in which, over a limited volume of space, there is no gravitational field, and relative to such a reference frame the velocity of light is equal to c . However, this is not true when gravitational fields are present. In addition to the lengths of rods and the rates of clocks the velocity of light is affected by a gravitational field. If gravitational fields are present the velocities of either material bodies or of light can assume *any numerical value* depending on the strength of the gravitational field. If one considers the rotating roundabout as being at rest, the centrifugal gravitational field assumes enormous values at large distances, and it is consistent with the theory of General Relativity for the velocities of distant bodies to exceed 3×10^8 m/sec under these conditions.¹¹⁷⁸

¹¹⁷⁸ *An Introduction to the Theory of Relativity*, William G. V. Rosser, London, Butterworths, 1964, p. 460, italics and comments in brackets added. Rosser adds: “Relative to an inertial frame the ‘fixed’ stars are at rest or moving with uniform

As we noted earlier, Einstein admitted to this very principle, and some critics used it to posit a major contradiction between Special and General Relativity. Einstein writes:

In the second place our result shows that, according to the general theory of relativity, the law of the constancy of the velocity of light *in vacuo*, which constitutes one of the two fundamental assumptions in the special theory of relativity and to which we have already frequently referred, cannot claim any unlimited validity. A curvature or rays of light can only take place when the velocity of propagation of light varies with position. Now we might think that as a consequence of this, the special theory of relativity and with it the whole theory of relativity would be laid in the dust. But in reality this is not the case. We can only conclude that the special theory of relativity cannot claim an unlimited domain of validity; its results hold only so long as we are able to disregard the influences of gravitational fields on the phenomena (e.g., of light).¹¹⁷⁹

As Rosser freely admits, General Relativity really has no choice in the matter. It must possess the inherent ability to make any point in the universe the center and produce coordinate transformations in accord with that center. Once it picks its center, then all the gravitational forces in the universe must balance. Hence, if an immobile Earth is chosen as the center, then all the forces in the universe will combine together such that, when Einstein's field equations are employed to calculate the forces, they will balance out just as when Einstein employed them for a moving Earth. In other words, one can choose any center and

velocity. However, relative to a reference frame accelerating relative to an inertial frame the stars are accelerating. It is quite feasible that accelerating masses give different gravitational forces from the gravitational forces due to the same masses when they are moving with uniform velocity. Thus the conditions in an accelerating reference frame are different from the conditions in inertial frames, since the stars are accelerating relative to the accelerating reference frame. It seems plausible to try to interpret inertial forces as gravitational forces due to the accelerations of the stars relative to the reference frame chosen." Einstein was criticized on this very point by Ph. Lenard in a 1917 open debate, later published in 1920. Lenard stated: "superluminal velocities seem really to create a difficulty for the principle of relativity; given that they arise in relation to an arbitrary body, as soon as they are attributed not to the body, but to the whole world, something which the principle of relativity in its simplest and heretofore existing form allows as equivalent" ("Allgemeine Diskussion über Relativitätstheorie," *Physikalische Zeitschrift*, 1920, pp. 666-668, cited in Kostro's *Einstein and the Ether*, p. 87). As an aside, Rosser also points out the following: "It has often been suggested that a direct experimental check of the principle of the constancy of the velocity of light is impossible, since one would have to assume it to true to synchronize the spatially separated clocks" (ibid., p. 133).

¹¹⁷⁹ Albert Einstein, *Relativity: The Special and the General Theory*, authorized translation by Robert W. Lawson, Three Rivers Press, New York, 1961, p. 85.

reformulate the relative forces of the entire universe from the perspective of that particular center using the mathematics of General Relativity. This application is understood as the “strong” principle of Relativity. If such a reciprocal relationship did not exist between respectively chosen centers, then General Relativity would be falsified; and if General Relativity is falsified, then modern science lacks any answer to the experiments which have demonstrated both a motionless Earth (Michelson-Morley, *et al.*) and absolute space (Sagnac, Michelson-Gale, *et al.*), and we are back to geocentrism in any case. Hence, General Relativity has uniquely fulfilled the qualifications of the proverbial dog chasing its tail.

Bondi's Geocentrism

Although like the rest of the physicists to whom we ascribe the word “geocentrism” in this chapter, Sir Hermann Bondi (d. 2005) would not explicitly refer to himself as a geocentrist, he, nevertheless, would be one of the first to admit that modern physics ably defends geocentric cosmology. This becomes abundantly clear in a 1994 paper Bondi wrote titled: “Angular Momentum of Cylindrical Systems in General Relativity.”¹¹⁸⁰ Bondi discovered two important facts from General Relativity that can be employed to defend geocentrism. First, Bondi derived and quantified what has been traditionally known as angular momentum, discovering in the process that the universe’s cylindrical symmetry prohibits gravitational waves from carrying angular momentum. This finding resolves a critique of geocentrism which posited that, to conserve angular momentum, the universe would slow down if a mass is raised on Earth and accelerate if the same mass were lowered. Bondi showed that, according to General Relativity, this is not the case, and thus the criticism is neutralized. Related to the above, Bondi also discovered that, according to General Relativity, all the mass beyond the [Schwarzschild](#) radius (where the tangential speed of the universe exceeds c) can be ignored, since it will contribute nothing more to the frame dragging and centrifugal forces already present. He writes:

The main point to note is that whereas in the newtonian, non-rotation of the reference system at infinity is taken for granted, in the relativistic treatment such rotation is permitted but irrelevant to the measure of angular momentum, which is an intrinsic characteristic of the material system....What is the nature of this limit? For such a cylinder the required angular velocity makes the tangential velocity at $r = r_2$ equal to the speed of light....Both the space drag on the core and A [angular momentum] will be unaffected by such outside layers....The conservation of A occurs even if gravitational waves are emitted by the cylinder. This is perhaps not surprising, since the cylindrical symmetry of the waves precludes their carrying angular momentum....Therefore the intrinsic nature of the angular momentum of the inner becomes patent as it is wholly unaffected by anything that goes on outside. Thus there is no transfer of angular momentum between outer and inner.¹¹⁸¹

Bondi arrived at the above derivation a little earlier in his paper:

¹¹⁸⁰ Royal Society Proceedings, Series A - Mathematical and Physical Sciences, vol. 446, no. 1926, July 8, 1994, pp. 57-66.

¹¹⁸¹ “Angular Momentum of Cylindrical Systems in General Relativity Royal Society Proceedings,” Series A - Mathematical and Physical Sciences, vol. 446, no. 1926, July 8, 1994, pp. 63-64.

It is a remarkable fact, discussed later, and of some relevance to Machian considerations that this unique conserved measure of angular momentum appropriate to the symmetry imposed is independent of any superposed state of rotation.¹¹⁸²

The same conclusion was stated in a different way in Bondi's abstract: "It emerges that angular momentum and space drag behave very differently as thicker and thicker spinning cylinders are studied." Hence, from the perspective of General Relativity, Bondi makes geocentrism completely feasible. That is, *if* the argument against geocentrism that appeals to the conservation of angular momentum is valid, it would violate the strong principle of relativity. To rescue Relativity theory from this failure, Bondi, by means of his meticulous tensor analysis, has simultaneously refuted the objection as it has traditionally been directed against geocentrism. The angular velocities used by Bondi are completely compatible with geocentric mechanics, since his analysis specifically validates cosmologies which have rotations at tangential velocities far greater than the speed of light.

The Lemaître-Tolman-Bondi Model

Another aspect of Bondi's teaching that makes geocentrism feasible is his development, along with [Georges Lemaître](#) and Richard Tolman, of the spherically symmetrical expanding universe.¹¹⁸³ Einstein's field equations allow at least two possible universes that were, more or less, diametrically opposed to one another: an isotropic homogeneous universe or an isotropic inhomogeneous universe. The former is the model that eventually developed into the Big Bang theory. As we noted earlier, such a universe will appear the same from every direction, and thus it has no center or distinguishing point. Today this model generally goes by the name of the Lemaître-Robertson-Walker model. But Einstein's field equations also allowed a spherical universe with a center, which was developed by Lemaître, and later Tolman, Bondi and a few others. As we noted in Chapter 3 in the discussion of Stephen Hawking's "modesty," is a spherical universe with a center, and most likely with Earth in that very center. Few admit the fact that Lemaître introduced a prior model, which was non-homogeneous and isotropic, and thus it necessarily comprised a center, that is, a distinct

¹¹⁸² "Angular Momentum of Cylindrical Systems in General Relativity Royal Society Proceedings," p. 61. My thanks to Martin Selbrede for bringing Bondi's paper to my attention, and for his help analyzing it.

¹¹⁸³ Hermann Bondi, "Spherically Symmetrical Models in General Relativity," *Monthly Notices of the Royal Astronomical Society*, vol. 107, Nos. 5, 6, 1947, pp. 410-425. By "spherically symmetrical" Bondi means that there is a center to the universe. He says as much in his paper: "We shall show that in our spherically symmetrical universe with the standard source at its center..." (*ibid.*, p. 413).

place from which the view of the universe would be unique. This is commonly known among physicists today as the Lemaître-Tolman-Bondi model.

Astrophysicist George Ellis, whom we noted previously had advocated that the Earth is in a central location in the universe, affirmed the Tolman-Bondi model in his award-winning 1978 paper. His abstract states:

It is shown that spherically symmetric static general relativistic cosmological space-times can reproduce the same cosmological observations as the currently favored Friedmann-Robertson-Walker universes, if the usual assumptions are made about the local physical laws determining the behavior of matter, provided that the universe is inhomogeneous and our galaxy is situated close to one of its centers.¹¹⁸⁴

Ellis adds that only three things can lead us to conclude that the universe we live in is not such a static space-time spherically symmetric universe: “(i) unverifiable a priori assumptions, (ii) detailed physical and astrophysical arguments, or (iii) observation of the time variation of cosmological quantities” and concludes:

...the standard models of a principle of uniformity (the cosmological or Copernican principle). This is assumed for *a priori* reasons and not tested by observations. However, it is precisely this principle that we wish to call into question. The static inhomogeneous model discussed in this paper shows that the usual unambiguous deduction that the universe is expanding is a consequence of an unverified assumption, namely, the uniformity assumption. *This assumption is made because it is believed to be unreasonable that we should be near the center of the Universe.* [Ellis adds footnote here citing Steven Weinberg’s *Gravitation and Cosmology*, 1972].¹¹⁸⁵

¹¹⁸⁴ George F. R. Ellis, “Is the Universe Expanding?” *General Relativity and Gravitation*, vol. 9, no. 2, February, 1978, p. 87.

¹¹⁸⁵ George F. R. Ellis, “Is the Universe Expanding?” *General Relativity and Gravitation*, vol. 9, no. 2, February, 1978, p. 87. In a subsequent work, Ellis, et al., state: “The problem is that while isotropy is directly observable, homogeneity (on a cosmological scale) is not. In the standard discussions the assumption of homogeneity is made *a priori*, either directly, or in some equivalent form (e.g., as the assumption that the Universe is isotropic for *all* observers), and so is not subjected to observational verification. Accordingly the standard ‘proof’ of the expansion of the Universe is based on an unverified *a priori* assumption” (George F. R. Ellis, R. Maartens and S. D. Nel, “The Expansion of the Universe,” *Monthly Notices of the Royal Astronomical Society*, 184, 1978, p. 440).

As we noted previously, the inhomogeneous models of the universe were being proposed mainly because there were simply too many problems cropping up in the homogeneous models. Modern cosmology was, as the saying goes, ‘caught between a rock and a hard place.’ Accepting the homogeneous models would produce universe that would either explode or implode. If they accepted the inhomogeneous model, they also had to accept the distinct possibility of an Earth-centered universe, which was apt to be rejected on “philosophical grounds.” To their consternation, cosmologists were producing very stable inhomogeneous universes, and doing so, ironically, with Einstein’s field equations.¹¹⁸⁶ Yet, as Gerard de Vaucouleurs noted:

With few exceptions, modern theories of cosmology have come to be variations on the homogeneous, isotropic models of general relativity. Other theories are usually referred to as ‘unorthodox,’ probably as a warning to students against heresy. When inhomogeneities [read: theories that can lead to an Earth-centered universe] are considered (if at all), they are treated as unimportant fluctuations amenable to first-order variational treatment.¹¹⁸⁷

¹¹⁸⁶ Summary analysis by Andrzej Krasinski, *Inhomogeneous Cosmological Models*, University of Cambridge Press, 1997; George A. Lemaitre, *The Expanding Universe*, 1933 Ann. Soc. Sci Bruxelles A53 51 (French), reprinted in 1997 in *General Relativity and Gravitation*, 29, 641; Hermann Bondi, “Spherically Symmetrical Models in General Relativity,” *Monthly Notices of the Royal Astronomical Society*, vol. 107, 410B, 1947; Richard Tolman, The Effect of Inhomogeneity on Cosmological Models, 1934 Proceedings of the National Academy of Sciences, 20 169, reprinted in 1997 *General Relativity and Gravitation*, 29 935; A. Krasinski A and C. Hellaby, “Structure Formation in the Lemaitre-Tolman model,” *Physical Review*, D65 023501, 2002; Guy C. Omer, Jr., “A Nonhomogeneous Cosmological Model,” *The Astrophysical Journal*, vol. 109, 1949, pp. 164-176; Ronald Kantowski, “The Coma Cluster as a Spherical Inhomogeneity in Relativistic Dust,” *The Astrophysical Journal*, vol. 155, March 1969; Gerard de Vaucouleurs, Science, “The Case for a Hierarchical Cosmology,” vol. 167, No. 3922, Feb. 27, 1970; W. B. Bonnor, “A Non-Uniform Relativistic Cosmological Model,” *Monthly Notices of the Royal Astronomical Society*, 159, 1972, pp. 261-268; Stamatia Mavrides, “Anomalous Hubble Expansion and Inhomogeneous Cosmological Models,” *Monthly Notices of the Royal Astronomical Society*, 177, 1976, pp. 709-716.

¹¹⁸⁷ Gerard de Vaucouleurs, “The Case for a Hierarchical Cosmology,” *Science*, vol. 167, No. 3922, 1970, p. 1204

Brill and Cohen's Geocentrism

In regards to the Schwarzschild radius and the Machian principle for geocentrism, Dieter R. Brill and Jeffrey M. Cohen write:

“[T]here is general agreement that the dragging along of inertial frames by rotating masses is a Machian effect. In particular, for mass shells comprising more nearly *all* the matter in the universe than those treated by Thirring, Mach's principle suggests that the inertial properties of space inside the shell no longer depend on the inertial frame at infinity, but are completely determined by the shell itself....A shell of matter of radius equal to its Schwarzschild radius has often been taken as an idealized cosmological model of our universe. Our result shows that in such a model there cannot be a rotation of the local inertial frame in the center relative to the large masses in the universe. In this sense our result explains why the 'fixed stars' are indeed fixed in our inertial frame, and in this sense the result is consistent with Mach's principle”¹¹⁸⁸

In this statement, Brill and Cohen agree with the above findings of Bondi concerning the irrelevance of the region beyond the Schwarzschild radius in determining inertial effects. But more importantly, they show that “there cannot be a rotation of the local inertial frame in the center relative to the large masses in the universe,” which means either the shell of “fixed stars” must be fixed around a rotating center, or the center must be the fixed point for a revolving shell, since, as they say, “the result is consistent with Mach's principle.”

Moon and Spencer's Geocentrism

The late M.I.T. professor Parry Moon and her partner Domina Spencer had been on the forefront of spelling out the unsettling implications of Relativity theory since their paper on Mach's principle first appeared in 1956. Not only did they perform experiments refuting Einstein's postulate on the speed of light, they demonstrated by the use of the concept of universal time that space must be explained in terms of Euclidean geometry.¹¹⁸⁹ Moon and Spencer also showed the disastrous implications for Relativity from both the 1913 Sagnac experiment and

¹¹⁸⁸ Dieter R. Brill and Jeffrey M. Cohen, “Rotating Masses and Their Effect on Inertial Frames,” *Physical Review*, 143, Issue 4, March 25, 1966, pp. 1012, 1014.

¹¹⁸⁹ Parry Moon and Domina Spencer, “Mach's Principle,” *Philosophy of Science*, 26, 1959, pp. 125-35.

the 1924 Michelson-Gale experiment.¹¹⁹⁰ All in all, their findings left geocentrism as a viable concern, with no evidence to refute its plausibility.

Møller's Geocentrism

Just a few years before Moon and Spencer, C. Møller published his *The Theory of Relativity* which took Einstein's thought to its logical conclusion: what happens if instead of having the Earth rotate, we make the universe revolve around the Earth? Møller used a ring model instead of Thirring's shell but came to the same conclusion as Thirring: a universe moving around the Earth cannot be denied. He writes:

...we may expect that a rotating spherical shell of uniform mass density will produce effects inside the shell similar to the rotation of the distant celestial masses....For a rotating shell of matter, however, Thirring found the interesting result that the field in the interior of the shell...is similar to the field in a rotating system of co-ordinates, thus leading to gravitational forces similar to the usual centrifugal and Coriolis forces. We shall here consider the somewhat simpler case of a rotating massive ring of rest mass M_0 and radius R , which is rotating clockwise in the xy -plane with angular velocity ω .¹¹⁹¹

He then concludes:

...the above considerations suggest a connection between the gravitational constant κ , the total mass M in the world [universe], and the mean distance R of the distant celestial masses, of the type $M\kappa c^2/4\pi R \approx 1$. It is interesting that the dependence on the angular velocity of the gravitational forces inside a rotating shell is exactly the same as in a rotating system of reference.¹¹⁹²

Perhaps frightened at the results, Møller excised them from his second edition published twenty years later, even though the Thirring model was widely available for public reading.

¹¹⁹⁰ Parry Moon, Domina Eberle Spencer and Euclid Eberle Moon, "The Michelson-Gale Experiment and its Effects on the Postulates of the Velocity of Light," *Physics Essays* 3, No. 4, 1990, pp. 421-428; Parry Moon, Domina Eberle Spencer and Shama Y. Uma, "The Sagnac Effect and the Postulates of the Velocity of Light," *Physics Essays* 4, No. 2, 1991, pp. 242-252.

¹¹⁹¹ C. Møller, *The Theory of Relativity*, Oxford, Clarendon Press, 1952, pp. 317-318.

¹¹⁹² C. Møller, *The Theory of Relativity*, Oxford: Clarendon Press, 1952, p. 320.

Brown's Geocentrism

Still in the same decade, G. Burniston Brown did something even more remarkable. Although it had been commonly thought that Newtonian mechanics supported only a heliocentric solar system, Brown showed how Newton's formulas serve the geocentric model just as well. Similar to Fred Hoyle's analysis we noted earlier, Brown sought to give an explanation of inertia "in terms of the total amount of matter in the universe and its distribution," which, we might add, is similar to the concept of a universal plenum appearing in various geocentric models. Brown then used this concept to explain other physical phenomena (red-shift, planetary perihelion, electromagnetic induction, etc.) by means of "non-instantaneous action-at-a-distance" (e.g., force moving no faster than the speed of light). To find the origin of, and to calculate the inertial forces, Brown uses the geocentric model of a rotating universe revolving around a stationary Earth:

...we can inquire into the problem of inertia. If this is not due to movement with respect to "absolute space," it ought to be due to surrounding matter, as suggested by Bishop Berkeley when criticizing Newton, and later by Mach. Now the evidence of astronomical observation at the present time is that the matter of the universe is distributed more or less uniformly, and to about the same distance in all directions. We must therefore consider the force on a moving body at the center of a spherical distribution of matter of uniform density ρ (dynamical units) and radius R . Using the postulate of physical relativity, we can take our particle of mass m [Earth] to be at the centre of coordinates, and the universe moving in the opposite direction.¹¹⁹³

Nightingale's Geocentrism

About twenty years later, J. David Nightingale transposed the Einsteinian equation of Mach's principle in terms of classical Newtonian physics, demonstrating the viability of a fixed Earth in a rotating

¹¹⁹³ G. B. Brown, "A Theory of Action at a Distance," *Proceedings of the Physical Society B*, 1955, vol. 68, p. 676. Brown continues: "On calculating the force...we find that for a steady velocity the force of the universe on m is zero, but for an acceleration f there is an opposing force equal to $-(4/3)(\pi m \rho R^2/c^2)(f)$. If we take this to be the force of inertia and write m_1 for the inertial mass, we shall have $F = m_1 f = 4/3 \pi \rho R^2/c^2 (mf)$. Thus the ratio of the attractive mass to the inertial mass of a body...should be given by $3c^2/4\pi\rho R^2$ or $G = 9c^4/16\pi^2\rho^2 R^4$. Taking $G = 6.7 \times 10^{-8}$ and $R = 2 \times 10^{27}$ cm [which is very close to Van Flandern's figure of 3.2×10^{27} cm] we can calculate the mean density of matter in the universe...which yields 10^{27} g/cm³, a result which agrees with present estimates (Zwicky 1952)." Brown also realized that "Stellar aberration therefore confirms a very important fact: we know the one-way velocity of light" (Letter to a Mr. Stout, October 15, 1980, copy on file).

universe.¹¹⁹⁴ Another twenty years passed, and the science community was still employing the geocentric model to establish Mach's principle.

Lynden-Bell's Geocentrism

D. Lynden-Bell, J. Katz, and J. Bičák wrote a ground-breaking paper on the relation between inertial frames and angular momentum. They refer to Lense and Thirring (1918) who, they say, "showed that, indeed, a rotating massive bucket many leagues thick [in answer to Mach's query] would drag around a Foucault pendulum..." They refer to the above paper by Brill and Cohen "who demonstrated that such dragging becomes complete when the radius of a massive rotating sphere reaches its Schwarzschild radius. Thus Mach's question is fully vindicated."¹¹⁹⁵ The Machian principle was further reinforced by Lindblom and Brill (1974) concerning their work on a massive spherical shell in free fall, which investigation "showed the remarkable result that the inertial frame inside such an infalling slowly rotating shell rotates uniformly at each moment...consistent with Wheeler's (1964) interpretation."¹¹⁹⁶

¹¹⁹⁴ J. David Nightingale, "Specific Physical Consequences of Mach's Principle," *American Journal of Physics*, 1977, vol. 45, pp. 376-379. The Einstein equation of Mach's principle was stated in his 1956 book *The Meaning of Relativity*, 5th edition, formula 118, p. 102 as $d/dt [(1 + \sigma)v] = c^2 \nabla \sigma + \partial A / \partial t - [v \times (\nabla \times A)]$ where $1 + \sigma$ inert mass (i.e., the Earth); $\partial A / \partial t$ is the inductive action of a large accelerated mass (i.e., the Universe); and the $[v \times (\nabla \times A)]$ represent the Coriolis force. Nightingale transposes this to the Newtonian formula: $d/dt [m_t (1 + \sigma)v] = m_t c^2 \sigma$ and finally $d/dt [(1 + \sigma)v] = c^2 \nabla \sigma + (4GM/rc^2)f$, where f = acceleration of M . After working out the equations he concludes: "It is interesting to note that, if we take away the entire mass of the observable universe (10^{79} baryons?), which for the sake of argument is situated on a 'celestial sphere' of average radius r , we find....It would not be unreasonable to contemplate that the inertial mass of a small test particle [i.e., Earth] could be entirely due to the mass of the observable universe...if M is taken to be the mass of the universe, the ratio of the accelerations is approximately 1:1. Thus, whatever wobbles the entire universe most certainly, according to Eq. 6 [...(4GM/rc²)f...] wobbles us likewise." As Misner, Thorne and Wheeler demonstrated, in this sense the Earth will be held in position by the entire universe, and any attempt to move the Earth will first have to move the universe. Nightingale also anticipates the "frame dragging" effect predicted by Thirring and Lense as he demonstrates the mathematical results of a ring rotating around a small test object (*ibid.*, p. 377). Of course, in our geocentric model we attribute these "dragging" effects to the ether that holds the composite of all the forces generated by the rotating universe, and these components can easily be applied to Einstein's equation of Mach's principle noted above.

¹¹⁹⁵ D. Lynden-Bell, J. Katz, and J. Bičák, "Mach's Principle from the Relativistic Constraint Equations," *Monthly Notices of the Royal Astronomical Society*, 272, 150, 1995.

¹¹⁹⁶ D. Lynden-Bell, p. 151.

The Lynden-Bell team stresses several times their “general proof that the angular momentum of any closed universe is zero,” which is to be expected in a spherical universe containing equal mass distribution. Interestingly enough, the null value for the angular momentum will provide the fixed and undisturbed cradle for the barycenter, the Earth, and thus Mach’s principle has inadvertently vindicated geocentrism once again.

Immediately after the above relationship is established, Lynden-Bell then cite Embacher (1988) who “has demonstrated that both dragging and centrifugal effects occur with the correct ratio within systems of rotating cylinders.”¹¹⁹⁷ In other words, even though the rotating universe generates no angular momentum to twist or rotate the Earth, it nevertheless generates other forces that are at work on the Earth’s surface (e.g., axial centrifugal force or “dragging effects”; radial centrifugal forces and Coriolis forces).

In the end, Lynden-Bell completely exonerate Mach’s principle, at least, as they say, “if the universe is closed.” In one of their concluding statements they write:

Therefore motions in a closed universe do provide a complete determination of the h_0k . Thus the observable motions of the heavenly bodies do in this sense provide the inertial frame, just as Mach supposed. THIS IS OUR PRIMARY RESULT.¹¹⁹⁸

¹¹⁹⁷ D. Lynden-Bell, p. 151.

¹¹⁹⁸ D. Lynden-Bell, p. 158, emphasis theirs.

Barbour and Bertotti's Geocentrism

Considering that Lynden-Bell's paper includes ten pages of the most rigorous mathematical analyses to date of Mach's principle (i.e., that the universe in rotation around a fixed Earth equates to an Earth in rotation within a fixed universe), geocentrism has been established by the very physics that sought to dethrone it in 1905.¹¹⁹⁹ With all this evidence available, it is no surprise that [Julian B. Barbour](#) admitted in 1994: "all solutions of Einstein's equations are Machian,"¹²⁰⁰ and it was Barbour's work with Bruno Bertotti in 1977 that was the foundation for his conclusion.

In this work, Barbour and Bertotti propose that "neither Special or General Relativity fulfills Mach's ideal," and thus set out to demonstrate Mach's principle in a classical, pre-relativistic framework. As they do so, they invoke Leibniz's conception of physics since he, along with Mach two hundred years later, were critical of Newtonian dynamics based on the fact that physics is "ultimately concerned with the relations between things and not between things and abstract space."¹²⁰¹ They pointed out that Newtonian physics had an inherent problem answering the phenomena of the bucket of swirling water (since Newton resorted to saying the cause of the water's concavity was due to the unproven "absolute space").

Mach's specific contribution was to suggest that the blatant contradiction...might be due to the presence of distant matter in the Universe. Thus, his conjecture, expressed in modern terms, was that a completely relational physics of the Universe considered as a whole could lead to an effective local physics...The present work shows, we believe, that this conjecture was completely correct and that the observed matter distribution in the Universe lends strong support to Mach's ideas.¹²⁰²

¹¹⁹⁹ The working definition of "Mach's Principle" with which Lynden-Bell is working is the one taken from Hermann Bondi in 1952: "By Mach's principle we mean that: 'All motions, velocities, rotations and accelerations are relative. Local inertial frames are determined through the distributions of energy and momentum in the Universe by some weighted averages of the apparent motions'" (D. Lynden-Bell, p. 151).

¹²⁰⁰ D. Lynden-Bell, p. 151. Bruno Bertotti was professor of Quantum Mechanics at the University of Pavia, Italy, and worked with Erwin Schrödinger at the Dublin Institute for Advanced Studies.

¹²⁰¹ J. B. Barbour and B. Bertotti, "Gravity and Inertia in a Machian Framework," *Il Nuovo Cimento*, 32B, 1:1-27, March 11, 1977, cited in "The Geocentric Papers," *Association for Biblical Astronomy*, Cleveland, Ohio. p. 88.

¹²⁰² Barbour and Bertotti, as cited in "The Geocentric Papers," p. 89.

After demonstrating through the use of Lagrangian derivatives the “invariant” component of Leibniz’s theory, and by assuming a non-rotating universe, the authors find that “the Galileo group can be derived dynamically from the Leibniz group,” and thus they are successful in deriving: (a) Berkeley’s contention against Newton’s version of inertia; (b) Newton’s laws, albeit with a “small correction” to account for Mercury’s perihelion; (c) an answer to Kepler’s “cosmic coincidences” between the parameters of the universe and planetary motion; (d) a Machian reason why light’s speed is limited to a “critical velocity” [300,000 km/sec] in the local environment, which is said not to be due to “space-time,” but to the “imprint of the Universe on local physics.”¹²⁰³ This “imprint” of the Universe the authors call *protophysics*.

To arrive at this final point, Barbour and Bertotti then present the case of a rotating universe around a fixed Earth. They can do so, of course, since there is no difference between a heliocentric or geocentric model in either Machian physics or General Relativity:

Let us first consider the case when the massive body is a rigid, uniform shell of mass M_0 and radius R_0 [e.g., the universe]. The test body [e.g., the Earth] is near the center of the shell (coincident with the center of the cosmological shell and the origin of co-ordinates); thus $r_i \ll R_0$.¹²⁰⁴

Employing the Machian model the authors also derive the Lense-Thirring effect associated with General Relativity, but insist that: “our calculation is, however, superior from a Machian point of view: in our model the space outside the shell does not have any absolute inertial properties (they are determined by the cosmological shell).” In other words, unlike General Relativity, the Machian model isn’t measured by recourse to an absolute reference point outside the universe. The Machian mechanics are self-contained.

To finish off the analysis, Barbour and Bertotti employ another Machian example: “Now we consider an analogous example: a rotating sphere [e.g., the universe] of radius a and mass m and a test particle [e.g.,

¹²⁰³ The authors add: “The averaged overall motion of the Universe is of necessity imprinted on local physics through its appearance in the ‘coupling constant’ $G = 4RR^2/M$. In the framework of the theory we have developed, it is a remarkable coincidence that the magnitude of \dot{R} is so close to the velocity of light. Nowhere has light entered into our considerations. This poses the following question: why does the local physics we observe around us have a distinguished velocity? The conventional answer is that the basic physical reality is space-time with a metric locally diagonalizable to the form (1, -1, -1, 1). This structure is assumed to be independent of the matter in the Universe. Our present work suggests quite a different explanation; it is that special relativity just reflects the imprint of the Universe on local physics.”

¹²⁰⁴ *Ibid.*, p. 98.

the Earth] at a distance $r \gg a$ from it [many light years in distance].” After running it through their working equation, the authors find:

[T]he first term of our theory: the gravitational action of a finite, spherical body at rest is not the same as if its mass were concentrated at the center, as happens both in Newtonian physics and in general relativity....The last term amounts to a small...increase of the gravitational constant...the internal motion mechanism, which of necessity leads to attractive gravity, explains gravity in a way radically different from all other theories.¹²⁰⁵

And so, Barbour and Bertotti’s work has not only advanced Machian mechanics from a mere theoretical concept to a rigorously supported mathematical system, but has also led to some startling principles of physics that were heretofore unknown, and which answer a variety of issues much more easily than the heliocentric model.

¹²⁰⁵ Barbour and Bertotti, p. 98.

Fred Hoyle and the Problem of Earth's Diurnal Motion

Although an Earth in diurnal motion provides Copernicans with a viable mechanical model of the movements of the solar system, it also creates various anomalies. One of these regards the effect of the tides on the rotation of the Earth. According to evolutionary cosmology, the Earth's spin has been steadily decreasing over the 4.5 billion years it has been in existence and has now reached the point that it rotates once in 24 hours. The main cause for this slowdown is said to be the tidal action of the Earth's oceans, which causes a drag on the rotation. As popular astronomer Fred Hoyle describes it:

In the past the Earth rotated considerably more rapidly than it does now: at the time of its origin the cycle of day and night may have been as short as 10 hours. The spin of the Earth must accordingly have been slowed down during the 4,000 million years or so that have elapsed since the early period of its life. The agency responsible for the braking action is known. It is just the twice-daily tides that are raised by the Moon and the Sun. The oceanic tides cause a frictional resistance when they impinge on the continental margins. This friction produces heat at the expense of the energy of rotation of the Earth, thereby slightly slowing the Earth's spin. In return for its effect on the Earth, the Moon experiences a force that pushes it gradually farther and farther away from us.¹²⁰⁶

So here we have two problems, and both, any mechanic might agree, is due to the fact that the more moving parts a machine contains, the more chance exists that something can go wrong. The Copernican system requires the Earth to possess a double movement (diurnal and translational) that must be in lock-step with the rest of the solar system and the universe at large. That's quite a demand on a little planet seeking to preserve its delicate balance of life. The geocentric system is much more simplified, requiring no effort from the Earth, least of all a double-effort, to keep pace with the universe, and thus little chance for it to upset its own environment. The only thing necessary is that the giant wheel of the universe keep turning, but its sheer mass makes this rotation almost effortless under the laws of inertia. The tides would not slow down the universe's rotation around Earth anymore than a drop of water would make the level of the oceans rise. Not so in the heliocentric system. The need for a rotating Earth not only puts an inordinate amount of pressure on the tiny planet to keep pace with the universe, it will cause tremendous stresses and strains on all the Earth's components. Earth must now adjust to, and compensate for, all the stresses and strains

¹²⁰⁶ *Frontiers in Astronomy*, pp. 15-16.

associated with movement, not the least of which is keeping the Earth in a complicated double motion. If, as Hoyle suggests, the tides slow the Earth's rotation, we should be able to measure this decrease year by year, no matter how small it is, for there is nothing magical about rotation that it should suddenly be satisfied when it reaches a 24-hour threshold.¹²⁰⁷ We can take a wild guess that Copernicus didn't think of these problems when he proposed his heliocentric system to correct the calendar.

The second problem (which seems to have slipped Hoyle's mind since he doesn't attempt an answer) is that if the moon has been steadily departing from the Earth during the same time the Earth has slowed from a 10-hour per day rotation to one of 24-hours over the last "4,000 million years," then the moon must be much farther away from us now than it was several million years ago. In fact, using lasers, we know precisely how much the moon falls out of its orbit – to the tune of 4 centimeters per year.¹²⁰⁸ That might not seem like much, but when you add up the decay over the time span Hoyle has proposed, it means the moon (assuming the same uniformitarian environment that scientists assume for their coveted theory of evolution), would have increased its radial distance by 16 billion centimeters in the course of "4,000 million years" (give or take a few million to account for the fact that the moon, according to solar evolutionary theory, may not yet have been in existence when the Earth was first formed). Still, in 4 billion years this amounts to 99,416 miles, which is about 40% of the moon's current distance from Earth. If we use evolution's current estimates of the Earth's age, the numbers are even greater, since 4.5 billion years yields 111,843 miles or 47% of today's Earth-moon distance. These calculations are based on an arithmetic proportion, but they might just as well be based on a geometric proportion, since physical laws would require the moon's recession in past time to have been more than 4 cm/year. In fact, the calculus shows that just 2 billion years ago the moon would have been less than 25,000 miles from Earth, and orbiting 3.5 times per day, thus causing tides at least a million times greater than

¹²⁰⁷ K. E. Veselov adds that: "It is an established fact that over the past 25 years the rotational speed of the Earth has been slowing down and changing with a one-year period. The duration of the diurnal period has during these years been increasing at an average rate of 12.5×10^{-3} second/year...the longitudes of the perihelia of the planets anomalously shift in 100 terrestrial years over appreciable distances....Tidal friction inside the Earth can account for only about one-sixth of the retardation of its rotation. Accordingly, the value of that retardation for the past 25 years obtained experimentally by employing atomic timing devices is simply dismissed as anomalous" ("Chance Coincidences or Natural Phenomena," *Pushing Gravity*, pp. 169-170).

¹²⁰⁸ NASA puts the recession at 3.8 cm/year ("Moon Slipping Away from Earth," *Geo*, Vol. 3, July 1981, p. 137). Current science holds that the moon is losing kinetic energy as it daily transfers mega watts of energy into the Earth's oceans (Gary D. Egbert and Richard D. Ray, "The Motion in the Ocean," *Nature*, July 15, 2000, p. 42).

they are today.¹²⁰⁹ Moreover, when the Earth was rotating once every 10 hours or so, in between the massive flooding caused by the moon's close proximity, such intermittent levels of light and darkness, exorbitant temperature fluctuations, and many other extreme environmental factors, would wreak havoc on the tender ecosystems that make life possible. Suffice it to say, none of these parameters are conducive to supporting life on Earth, especially in the uniformitarian environment upon which evolution so heavily depends.¹²¹⁰

Of course, Hoyle's bigger problem is trying to explain how, if the tides are continually producing a braking effect on the Earth's rotation, the Earth can now sustain a rotation period of 24-hours, especially if in the past it decreased from a 10-hour per day rotation. Here is Hoyle's solution:

Now the atmosphere of the Earth oscillates up and down....Not only this, but the atmosphere is pushed by the same forces as those that raise the oceanic tides...But the force due to the Moon...does not act in resonance with the oscillations of the atmosphere and consequently does not build up appreciable motions of the atmospheric gases. The somewhat weaker pushes due to the Sun do act in resonance with the atmosphere, however. The result is that very considerable up and down motions of the air are set up. These motions are accompanied by oscillations of pressure....The variations occur twice daily,

¹²⁰⁹ Current science tries to explain this anomaly by suggesting that tidal forces were less than they are today. Bruce Bills and Richard Ray state: "The torques were therefore correspondingly smaller than they would otherwise have been if the admittances had maintained their present day values" ("Lunar Orbital Evolution: A Synthesis of Recent Results," *Geophysical Research Letters* 26, 19: 3045-3048, October 1, 1999, p. 3046; also B. A. Kagan and N. B. Maslova, "A stochastic model of the Earth-Moon tidal evolution accounting for the cyclic variations of resonant properties of the ocean: An asymptotic solution," *Earth, Moon and Planets* 66: 173-188, 1994; and G. E. Williams, "Geological constraints on the Precambrian history of the Earth's rotation and the Moon's orbit," *Reviews of Geophysics* 38, 1: 37-59, February, 2000. All these explanations, however, are quite self-serving since they choose parameters that conveniently fit into an Earth/moon age of 4.5 billion years. They also fail to account for the additional braking effect that higher tides would have caused, as well as the additional effect the Earth would have had on the moon when their distance was closer and the Earth was spinning faster.

¹²¹⁰ Veselov adds: "In 100 terrestrial years the Moon should turn in relation to the Earth by 372 seconds of arc, and in 1000 years, by 37220 seconds, i.e., by almost one-fifth of its radius. Apart from the secular shortening of the period of the Moon's revolution around the Earth by 0.0009 seconds a year, there should be periodic changes of that shortening with an amplitude of 0.0052 seconds, periodic changes of the duration of the rotational period by 0.052 seconds, and a swaying of the pericenter by 0.21 seconds....The change in the periods of the revolution of the sixth and seventh satellites of Jupiter is of the order of 0.002 sec/terrestrial year, and the rotation of the pericenter longitude of Amalthea amounts to approximately 2000 seconds per 100 terrestrial years... ("Chance Coincidences or Natural Phenomena," *Pushing Gravity*, p. 181).

just as the oceanic tides do. The pressure is found to be at a maximum about two hours before midday and about two hours before midnight. By a careful calculation it can be shown that this precedence of the atmospheric tides before midday and midnight cause the gravitational field of the sun to put a twist on the Earth tending to speed it up...the twist is comparable with the slowing-down effect of the oceanic tides, just as Holmberg's theory requires it to be.¹²¹¹

So here Hoyle attempts to give us the impression that this system is as precise as a clock. After all, "two hours before midday and about two hours before midnight" this adjustment by the sun takes place "by a careful calculation," so we need not worry that our sleep habits will ever be disturbed. Then again, the clock Hoyle envisions has only relative precision, for he then adds that the results are only based on "the law of averages":

It is important to realize that the speeding-up process need not exactly compensate all the time for the slowing-down effect of the oceanic tides. It is sufficient if the two processes compensate each other on the average, averages being calculated over say a time of 100,000 years. Indeed exact equality at all times is not to be expected for the reason that the slowing effect is likely to vary quite appreciably and quickly from one time to another....But now here is the crucial point. As the Earth slowed to a day of 24 hours the pushes of the Sun gradually came into resonance with the oscillation of the atmosphere....This went on until the speeding-up process came into average balance with the slowing effect of the oceanic tides. A state of balance has been operative ever since.¹²¹²

Now if the effect of speeding-up produced by the sun can "vary quite appreciably and quickly," yet tidal action occurs twice daily without fail and always has the effect of slowing down the Earth, should we not experience at least a fraction of this difference in our present day? No, Hoyle assures us, this process magically reached a "state of balance" by the time we humans reached a point of evolutionary cognition, and we can now work backwards, as it were, and figure out that our hominid ancestors did not enjoy eight hours of nocturnal sleep as we humans do.

¹²¹¹ *Frontiers of Astronomy*, pp. 16-17. Without any explanation or proof why Holmberg's theory would do so, Hoyle adds that Holmberg's "very recent theory...disagrees that the cycle of day and night will ever take longer than 24 hours in the future." It is rather amazing how Hoyle puts such trust in a "very recent theory" to explain such a crucial part of his Copernican universe, yet all without the slightest proof to the reader. We are to take it on Hoyle's word that Holmberg has it all worked out, and no further inquiry is required.

¹²¹² *Ibid.*, p. 17.

This is a good example of what Van der Kamp calls “that invalid theoretical syllogism, the *modus ponendo ponens*.”¹²¹³ Such self-serving cosmological models, propped up by nothing more than anachronistic logic and a “very recent theory” are common in the modern Copernican world. Although Hoyle is seeking to salvage the Copernican system, the laws of physics simply will not allow him to ignore the braking effect of tidal action, so he must have another mechanism to compensate for the anomaly that tidal action creates for a 24-hour rotation. The sun, which, previous to the anomaly, is understood as that solitary force which inhibits the Earth’s wish to fly off into space, is now assigned to give an opposite force in order to make the Earth rotate faster, and just enough so that it doesn’t disturb the 24-hour cycle. What incredible powers of distinction this sun possesses! Of course, no such contradictory forces, fine-tuning, or “law of averages” exist in the geocentric model, for there isn’t a force in the cosmos, including tidal forces, that can stop the gigantic ball of the universe from rotating once it is given its initial push. It will be as precise as a Swiss watch, from now until doomsday, and without all the moving parts working against each other.

¹²¹³ *De Labore Solis*, p. 28. Van der Kamp writes: “If situation P is the case, we agree, then we shall observe the phenomenon Q. Now indeed we observe Q. Does it therefore follow that P is the factual state of affairs? By no means necessarily, for Q may be caused by a variety of other circumstances. As one of my textbooks of logic remarks: ‘We shall have frequent occasions to call the reader’s attention to this fallacy. It is sometimes committed by eminent men of science, who fail to distinguish between necessary and probable inferences, or who disregard the distinction between demonstrating a proposition and verifying it.’”

At that time Jesus answered and said: I confess to thee,
 O Father, Lord of Heaven and Earth, because thou hast
 hid these things from the wise and prudent, and hast
 revealed them to little ones.

Yea, Father: for so hath it
 seemed good in thy sight.

Come to me all you that labor and are burdened, and I
 will refresh you.

Take up my yoke upon you, and learn of me, because I
 am meek, and humble of heart: And you shall find rest
 to your souls.

For my yoke is sweet and my burden light.

Matthew 11:25-26, 28-30

She put her hand to the tent peg and her right hand to
 the workmen's mallet; she struck Sisera a blow, she
 crushed his head, she shattered and pierced his temple.

He sank, he fell, he lay still at her feet; at her feet he
 sank, he fell; where he sank, there he fell dead.

Judges 5:26-27

I will put enmities between thee and the woman, and thy
 seed and her seed: she shall crush thy head, and thou
 shalt lie in wait for her heel.

Genesis 3:15 (DR)

"If I have spoken to you earthly things, and you believe not; how will you believe, if I shall speak to you heavenly things?"

Jesus Christ¹²¹⁴

"The person who thinks there can be any real conflict between science and religion must be either very young in science or very ignorant of religion."

Joseph Henry¹²¹⁵

"A conflict arises when a religious community insists on the absolute truthfulness of all statements recorded in the Bible."

Albert Einstein¹²¹⁶

"If God had spoken scientifically even an Einstein would not have understood him."

Walter van der Kamp¹²¹⁷

"It follows from this that our notions of physical reality can never be final. We must always be ready to change these notions..."

Albert Einstein¹²¹⁸

¹²¹⁴ John 3:12.

¹²¹⁵ Joseph Henry, American physicist (d. 1878), attributed.

¹²¹⁶ Albert Einstein, *Ideas and Opinions*, New York, Crown Publishers, 1954, Wing Books, 1984, p. 45.

¹²¹⁷ *Bulletin of the Tychoonian Society*, December 1981, p. 17.

¹²¹⁸ Albert Einstein, *Ideas and Opinions*, New York, Crown Publishers, 1954, Wing Books, 1984, p. 266.

Chapter 11

Hildegardian Geocentrism

Aristotelian Cosmology Meets Modern Science

A Brief History of Hildegard's Life

At the beginning of the second millennium stood a woman gifted with insight into cosmology that, as we look in hindsight, seems to have far exceeded the theories of Copernicus, Galileo, Kepler, Newton, and Einstein. The woman was [Hildegard von Bingen](#), the eleventh century German mystic and Benedictine Abbess whom some call “The most gifted woman of the epoch.”¹²¹⁹ She was born in 1098 and died at the age of 81, in 1179. Her complete story is truly amazing, but, of course, we are only interested in her cosmological revelations.

Hildegard received a series of mystical visions concerning the cosmos beginning in childhood, which became more intense in her forties. She writes:

Up to my fifteenth year I saw much, and related some of the things I had seen to others, who would inquire with astonishment whence such things might come.

Her main visions are divided into three eras: *Scivias* (1152-1158); *The Book of Life's Merits* (1158-1163); and finally *The Book of Divine Works* (1163-1173), the last being the one we will investigate. The book was written in Hildegard's native medieval German, and its contents have been reproduced and analyzed by Dr. Helmut Posch in the book titled *Das wahre Weltbild nach Hildegard von Bingen* (“The World According to Hildegard von Bingen”).¹²²⁰ We are indebted to him for translating Hildegard's words and interpreting them in modern scientific terms. We will add our own interpretation to Posch's as is appropriate in accord with the scientific information we have produced in this book.

In Hildegard's visions we find one of the most remarkable treatises on cosmology ever told. It is elaborate and quite detailed. It answers many of the questions with which modern science has struggled but failed to obtain satisfying solutions. For example, Hildegard helps in explaining the nature of gravity, something that has escaped the

¹²¹⁹ Michael Seidlmayer, *Currents of Mediaeval Thought: With Special Reference to Germany*, translated by D. Barker, Oxford, Basil Blackwell, 1960, p. 92.

¹²²⁰ Helmut Posch, *Das wahre Weltbild nach Hildegard von Bingen*, Deutsche Bibliothek – CIP – Einheitsaufnahme, Aufl. – A-4880 St. Georgen, 1998.

understanding of modern science to this very day, although many theories, from Descartes' vortexes to Quantum Loop theory, have been put forth. She explains the nature of light and inertia, two other phenomena modern science has long sought to understand but without much success. She explains the nature of space and its makeup, a solution, we will see, that is diametrically opposed to the "*in vacuo*" concept used in Relativity theory, but in agreement with the particulate model we have been discussing in this book. She explains the mechanics of solar and planetary movement from a Tychonic perspective (i.e., the planets revolve around the sun, but the sun revolves around the Earth), over four hundred years before Tycho Brahe devised it in opposition to Galileo's solar system, and she did so in the midst of the reigning Ptolemaic system.

In the wake of Newton's and Einstein's inability to explain such mundane phenomena as why a body in motion remains in motion (inertia) or why bodies fall radially toward the center of mass, or even modern science's inability to explain the true nature of light (wave or particle), the Aristotelian postulates (e.g. that the Earth is the absolute standard of rest; that no object has momentum or acceleration unless a force acts upon it, *etc.*) remains an open and viable explanation of celestial mechanics. [Stephen Hawking](#), for all his prejudices against geocentrism, put it well when he said:

The big difference between the ideas of Aristotle and those of Galileo and Newton is that Aristotle believed in a preferred state of rest, which any body would take up if it was not driven by some force or impulse. In particular, he thought that the Earth was at rest. But it follows from Newton's laws that there is no unique standard of rest....Is Newton right or is Aristotle, and how do you tell?....Does it really matter whether Aristotle or Newton is correct? Is this merely a difference in outlook or philosophy, or is it an issue important to science? Actually, the lack of an absolute standard of rest has deep implications for physics: it means that we cannot determine whether two events that took place at different times occurred in the same position in space....Newton was very worried by this lack of absolute position, or absolute space, as it was called, because it did not accord with his idea of an absolute God. In fact, he refused to accept the lack of absolute space, even though his laws implied it.¹²²¹

We can see from Hawking's assessment how important is the question of whether or not the Earth is at rest. It is no exaggeration to say that all of physics and cosmology divide right at this point, and if either Aristotle, on the one hand, or Galileo, Newton and Einstein, on the other

¹²²¹ Stephen Hawking and Leonard Mlodinow, *A Briefer History of Time*, New York, Bantam Dell, 2005, pp. 22-24.

hand, took the wrong path, then all subsequent physics and cosmology produced by the party at fault must be erroneous. The stakes couldn't be higher.

Whereas Galileo, Newton and Einstein gave us only mathematical equations, Hildegard, following Aristotle, gives us the physical mechanisms behind the math. In fact, as she explains the mechanics of the universe in basic Aristotelian thought forms, she is aided by visions that provide comprehensive answers that not even Aristotle's imagination could have created. Her understanding of the cosmos advances well beyond both her ancient and modern counterparts.

All this, of course, raises the question of how this simple woman could have known the nature of the cosmos so intimately. To our knowledge, she was never made privy to the Aristotelian library discovered in the Middle East two centuries earlier. But not only is Hildegard's use of Aristotle a phenomenon in itself, her visions often modify and correct the places in which Aristotelian physics and cosmology needed help. So elaborate and advanced is Hildegard's model of the universe that we are more or less compelled to accept that it came either partially or totally from divine sources. (If not, then we could be as quick to conclude that her visions, as the adage is commonly stated, may not be worth the paper they are written on). Her visions have explanations that any modern-day scientist would understand, even if he didn't agree with them. As such, one cannot lightly dismiss her cosmology by countering that she might have been deranged or hallucinating, for Hildegard was a well-respected intellect in her day as she engaged in all kinds of aesthetic and mind-demanding activities, from musical composition to theological writing, but she had little science knowledge that could provide the elaborate and technical explanations of the universe we find in her writings. She studied neither atoms nor gravity yet from her vision she seems to know about both, and many other related issues, in ways which even a modern scientist would marvel.

Some skeptic might resort to accusing her of being demonically possessed, a state of mind that somehow gave her the ability to produce all kinds of extraordinary insights. But this accusation is quickly neutralized. First, devils do not produce such technically accurate designs. Second, if one decides to open up the possibility of the preternatural to Hildegard, one consequently opens up the supernatural as well. Thus the objection loses its impact, not to mention the fact that no one in Hildegard's day, including layfolk and church hierarchy, saw any evidence in her life which would merit such a derogatory accusation. Rather, Hildegard was exhorted and authorized to publish her writings by Pope Eugenius III (1145-1153) after he had commissioned Albergo of Chiny, the bishop of Verdun, to investigate her writings. Hildegard's immediate clerical authority in Mainz, Bishop Heinrich, pronounced her visions as having divine origin. As her fame spread far and wide, many

prominent clerics and layman sought her wisdom, including St. Bernard of Clairvaux, St. Elizabeth of Schoenau, the emperor Frederick Barbarossa, King Conrad III, and dozens of archbishops and bishops throughout Europe. The Roman Catholic Church has “beatified” Hildegard, which is the last step toward sainthood.

Earth: The Center of Six Cosmic Layers

To no surprise, Hildegard's visions of cosmology agree precisely with the geocentric foundation laid down in Scripture; which foundation was promoted, without exception, by a consensus of the Church Fathers; continued faithfully by Thomas Aquinas and the medievals; and confirmed by papal and conciliar decrees – not something the devil would want to accommodate if he were trying to marginalize someone against the patriarchs and saints of the Church.

As Hildegard would agree, if one takes Genesis 1:1-2 at face value, one must hold that the Earth was created before the sun and stars; that it is the center point of the whole cosmos and is surrounded by the firmament that reaches to the limits of the universe; and a firmament upon which waters are presently resting. Thus was the cosmology of Hildegard's visions, but with much more detail. Accordingly, as we have outlined the scientific support for a geocentric universe in the foregoing chapters, we will now consult Hildegard's visions to give substance to many of those facts and queries.

To begin, Hildegard's visions revealed that the Earth was in the very center of the universe, serving as the center for the compass that points north, east, south and west stretching to the edge of the universe, a universe that is finite and spherical. She revealed that the whole universe rotates around the Earth and that the Earth itself has no movement. Surrounding the Earth are [six spherical layers](#), composed either of fire, water or air.¹²²² The two outer layers are composed of fire (energy). A layer underneath the fire layers is composed of "ether." The two layers nearest to Earth are composed of air, the Earth's atmosphere being closest and described as "very clean," followed by an "illuminated and humid" air layer. Above the two air layers is a water layer, which corresponds to the "waters above the firmament" recorded in Genesis 1:6-9. Hildegard writes that these waters "are material unlike the lower waters, that is, much finer and invisible to our eyes."¹²²³ The words

¹²²² Hildegard writes: "In its outer vault appeared a circle of bright Fire around the spherical wheel and immediately under it, without gap, another circle of black Fire. The thickness of the bright Fire was double of the black Fire. The two circles were linked as if they consisted of only one. Under the circle of black Fire, appeared another circle as consisting of pure ether, with the same thickness as the two other ones together. Under this ether circle there is a circle of humid Air, with the thickness of the circle of bright Fire. Under the circle of humid Air appeared another one consisting of very clear Air, which in its consistency was similar to a nerve of the human body. It was wide like the circle of black Fire. These two circles were also linked as if they consisted of only one. Under this very white Air there is also a thin layer of Air similar to some fluffy down, with dark accumulated clouds, which are divided in the whole spherical area. All these six areas were bound without an interstice. The outer circle inundated all the other spheres with its Fire, but the water area humidified all the other ones with its humidity" (*Welt and Mensch*, 35, *Das wahre Weltbild*, p. 82).

“finer” and “invisible” could mean that the water is extremely rarified and thus invisible, or that it is rarified and very far away from Earth and therefore not seen with the unaided eye. The corollary point seems to be that the water Hildegard has in view is not solid or liquid, but gaseous.

Scripture verifies that water, and the corresponding layers in Hildegard’s vision, exist in these remote regions of the celestial orbs. In Psalm 104:1-6 [103:1-6], David writes:

- 1 O Lord my God, you are exceedingly great. You have put on praise and beauty:
- 2 And are clothed with **light** as with a garment. Who stretches out the heaven like a pavilion:
- 3 Who covers the higher rooms thereof with **water**. Who makes the **clouds** your chariot: who walks upon the wings of the **winds**.
- 4 Who makes your angels spirits: and your ministers a burning **fire**.
- 5 Who has founded the **earth** upon its own bases: it shall not be moved for ever and ever.
- 6 The **deep** like a garment is its clothing: above the mountains shall the **waters** stand.

¹²²³ Hildegard, *Die göttlichen Werke*, 56; Posch, *Das wahre Weltbild*, p. 84.

Water in the Remote Recesses of Outer Space

Prior to our present era, water in outer space was undetectable. Modern science, however, has discovered vast amounts of water in the recesses of space. As West Marrin writes:

Water is certainly not limited by the confines of this planet and is, in fact, one [of] the most common molecules in the universe. The more that science looks for water in the cosmos, the more places they seem to find it.¹²²⁴

Scientists have known for quite a while that massive water clouds exist in outer space. As soon as telescopes were sensitive enough to detect it, the reports came in quite frequently. One of the first was from the University of California that reported in *Science*:

Radio spectral line radiation of water molecules at a wavelength of 1.35 centimeters has been measured from eight sources in the galaxy. The sources are less than 7 arcminutes in diameter, have extremely high brightness, temperatures, and show many spectral features...Seven of the eight H₂O line emission sources which have been observed agree in position with known hydroxide emission sources within the accuracy of measurement.¹²²⁵

The article goes on to say that the sizes of the water clouds range in length to about 80 billion miles, a distance which is 27 times the distance between the sun and Pluto. A more recent newspaper report concurred with this evidence:

Astronomers have detected water at the most distant point from Earth so far, a discovery that adds to the growing belief this essential ingredient of life may be present throughout the

¹²²⁴ West Marrin, *Universal Water: The Ancient Wisdom and Scientific Theory of Water*, Hawaii, Interocean Publishing, 2002, p. 67. Water has also been found on the surface of the sun. It survives the high temperatures of the sun's photosphere since the water is confined to the dark, cool regions of sunspots whose temperature is less than 3,500 Kelvin. Marrin adds: "The water discovered in the Sun and in various stars is understandably known as hot water, but it is unmistakably water, based on the wavelengths of infrared radiation that are absorbed...water is believed to filter out certain frequencies of EM radiation that are given off by stars....When these stars die, they appear to go out in a flood of water as This Element plays out its less glamorous role of mediating the destruction or recycling of the universe's stuff" (*ibid.*, pp. 78-79).

¹²²⁵ S. H. Knowles, *et al.*, "Spectra, Variability, Size, and Polarization of H₂O Microwave Emission Sources in the Galaxy," *Science*, March 7, 1969, pp. 1055, 1057. As Basil the Great says: "Let us understand that by water, water is meant; for the dividing of the waters by the firmament let us accept the reason which has been given us" (*Homilies*, 3, 9).

universe. The water was found 200 million light years away by radio telescope in Markarian 1...said James A. Braatz, an astronomer at the University of Maryland.¹²²⁶

Often water is found in the strangest places:

Recently, two of the brightest supergiants in the galaxy, Betelgeuse (in the Orion constellation) and Antares (in the Scorpio constellation), were discovered to actually have water in their photospheres, as well as in the circumstellar material surrounding their photospheres....The structure of photospheres in cool stars is due primarily to the opacity of water, which is one of the most abundant molecules in such stars. The presence of photospheric water in these red supergiants confirms that it is located within the star itself and is not just a component of the dust and gas clouds surrounding stars. Aging supergiants have been observed to release massive amounts of water as they die.¹²²⁷

Regarding the water in and surrounding the constellation Orion, Marrin adds:

Recent data indicate that this cloud complex contains an extremely high concentration of water vapor, which has been estimated on the order of 1 part in 2,000 or about 500 parts per million. This is about twenty times greater than the water concentration in other interstellar gas clouds and represents enough water to fill the Earth's oceans ten million times!¹²²⁸

In addition to water's ubiquity, modern science is continually amazed at the makeup and function of the water molecule. The simple combination of two hydrogen atoms and one oxygen atom has, as it turns out, a dizzying array of combinations and actions that is highly unique among nature's compounds. As Marrin tells it:

¹²²⁶ "Water found on distant galaxy," *Associated Press*, Minneapolis, 1994. Braatz continues to find water in space. As of 2005, Braatz's most recent abstract reveals a "Search for Extragalactic Water Maser Emission with the GBT: Independent Measurement of the Hubble Constant: Consequently, we propose to conduct a search for extragalactic water maser emission in edge-on Seyfert 2 and LINER systems. Considering the detection rates of our recent GBT surveys among edge-on active systems, we expect to detect ~20 new sources, thereby increasing the number of known water maser sources by nearly 50%" (Conducted by the National Radio Astronomy Observatory).

¹²²⁷ *Universal Water*, pp. 76-77.

¹²²⁸ *Universal Water*, p. 78.

Water is not simply H₂O, but rather is a complex network of interconnected water molecules, especially in its solid and liquid states. Moreover, this network is constantly shifting its connections (known as hydrogen bonds) among neighbors so that the resulting geometries are exchanged as many as a trillion times per second....Many of water's most puzzling properties, as well as its ability to solvate or "include" an amazing variety of substances within its network, are a direct result of these molecular gymnastics...¹²²⁹

And later:

Based on the percentage of water versus carbon-containing compounds in biological organisms, there is little doubt that the biosphere is water-based rather than carbon-based. Not only does water constitute most of our mass, it is required in essentially every biological structure and process. It was formerly understood that water simply acted as the solvent or matrix within which the carbon-containing compounds (e.g., DNA, proteins) orchestrated the drama that creates and sustains biological life. It now appears as though water participates in directing the processes to an extent that was previously unimagined.¹²³⁰

The purpose of detailing the above facts is to point out that, as modern science has confirmed the presence of water in outer space, it is certainly no stretch of the imagination to accept that there is "water above the firmament," as both Genesis 1:6-9 and Psalm 148:4 indicate. Considering the complexity and versatility of the water molecule, it no doubt plays a vital role both on Earth and in the cosmos, the latter being a dimension of water's existence that science is just now beginning to discover and confirm. We will see more of the precise function of this cosmic water later in Hildegard's writing.

¹²²⁹ *Universal Water*, p. 93.

¹²³⁰ *Universal Water*, p. 125.

Scriptural Accounts of Primordial Water and Plasma

As we noted above, according to Hildegard the water above the firmament is just one of six layers surrounding the Earth. If this is, indeed, the correct understanding of the structure of the universe, we can then reconstruct the process of its development and its constitution by employing other information from Scripture. The relationship between the layers is expressed in various passages. For example, 2 Peter 3:5 confirms Genesis 1:2's stipulation that the Earth was originally created inside a spherical mass of water:

...that by the word of God the heavens existed long ago, and an Earth formed out of water and by means of water, through which the world that then existed was deluged with water and perished. But by the same word the heavens and Earth that now exist have been stored up for fire, being kept until the day of judgment and destruction of ungodly men. (RSV).

The clause “Earth formed out of and by means of water” is the Greek *γη ἐξ ὕδατος καὶ δι' ὕδατος*., wherein *ἐξ* means the Earth came from water, while the Greek *δι*, in this case, does not mean “through” but is closer to “between,” and thus tells us that the Earth was surrounded by water (i.e., water covered the entire spherical circumference), and held there, as Peter says, by the word of God. The original mass of water surrounding the Earth was huge, measuring multi-thousands of miles in diameter, since later it would be used to cover the vast circumference assigned to it in the distant cosmos. Hildegard tells us that the original water surrounding the Earth was [solid ice](#), until the Spirit moved upon it and light was created.¹²³¹ Consequently, the Earth of the First day of creation was like a seed in the middle of a vast frozen ocean. We can assume that once the light was created, its heat melted the ice. Moreover, since science shows that a great residue of water remains in the cosmos, we can surmise that as the firmament expanded on the Second day and took the greater portion of the primordial waters with it to form the “waters above the firmament,” a substantial residue of that water was left in the cosmos and it is this amount that science is now detecting in outer space, and whose importance we will discover momentarily.

In addition, 2Peter 3:6 indicates that the original water surrounding the Earth was later employed in the Great Flood (Genesis 7-9). This does not necessarily mean that the “waters above the firmament” were called down, for they are permanently fixed in their respective cosmic layer; rather, the water left behind in the cosmos after the

¹²³¹ “During the Creation, the Water was then cold and didn't flow, while the Earth was still empty. But the Spirit of God moved up the waters and heated them, so that they should contain the Fire and flow as liquid” (*Ursachen u. Behandlung der Krankheiten*, 68; *Das wahre Weltbild*, p. 89).

expansion of the firmament could have been accumulated and dispersed on the Earth at the proper time, and its source is thus appropriately called the “windows of the heavens” (Genesis 7:11; 8:2). Since, as noted above, astronomers have discovered huge water clouds in space that stretch in length by as much as 27 times the distance from the sun to Pluto and could thus fill our oceans a billion times over, it is certainly reasonable to surmise that such massive deposits of water in space could have been used in the Great Flood. The water presently found in our local system may be the remnants of that event.

Interestingly enough, St. Peter says in the same context:

But by the same word the heavens and Earth that now exist have been stored up for fire, being kept until the day of judgment...the heavens will pass away with a loud noise, and the elements will be dissolved with fire, and the Earth and the works that are upon it will be burned up” (2 Peter 3:7,10).

The source of this destructive energy may be Hildegard’s two outer layers of “fire.” We can surmise that at the appropriate time they will be brought down from their remote recesses in space and squeezed toward the center of the universe until the world is destroyed. As opposed to the *Big Bang*, we might call this *The Big Implosion*. In the beginning of creation, however, what most likely occurred is that these two layers of energy originated from the “light” created on the First day. This primordial light (which was distinct from the sun and stars that would not be created until the Fourth day), initiated the day/night sequence on Earth for the first three days of the creation week. The daylight was produced by a confinement of the light to less than a hemisphere (Genesis 1:3 says “and God separated the light from the darkness”), which light moved around the Earth every twenty-four hours, perhaps in tandem with the Spirit that “moved over the face of the waters.”

One way in which the luminosity would be possible is if the light of the First day were in the form of a fire or plasma, since in that form it can be contained and moved.¹²³² For the purposes of comparison, the sun

¹²³² Here we note that Aristotle held a view of light close to the modern view, that is, that light is ἐνέργεια (energy) and travels through or vibrates in a διαφανές (diaphanes) or medium filling all of space. This is close to the Pythagorean view that understood light as a stream of particles that hit the eye, and opposed to the view of Plato that the eye emits a “divine fire” that is directed to the object. The Arabs of the Middle Ages adopted Pythagorus’ view. It wasn’t until 1690 that a wave theory of light was proposed by Huygens, and Newton understood it as “vibrations in the ether,” thus developing the view of Aristotle. Today the theory of what constitutes light is still not settled. It is best described as waves that carry particles or waves composed of particles, since light has properties both of a wave and of particles. As Oliver Lodge once quipped: “the two concepts are like a shark and a tiger, each supreme in its own element and helpless in that of the other.”

(which modern science has confirmed is a giant ball of fire), is also called a “light” in Genesis 1:14-17, and the sun is also assigned the same function, that is, “to separate the light from the darkness” (Gn 1:18). Presently, as the sun revolves around the Earth, it creates the day/night sequence. In the same way, the rotational movement given to the primordial light of the First day was the means by which God “separated the light from the darkness” on the first three days. Hildegard speaks in a similar way:

Almighty God, who is life without beginning and without end, and who constantly knows everything, made the material for all heavenly things and all mundane things together, that is, heaven as lucent matter, and earth, which was opaque matter. This luminous matter, however, from the glory of eternity flashed like a dense light that lit up over the opaque matter in such a way as to join itself to it. And the two substances were created at the same time *and appeared as if in a circular orbit*....The six days are six acts; for the beginning and the completion of each act is called a day. Neither was there an interval after the creation of primary matter, but instantly, as it were, the Spirit of God hovered over the waters, and afterwards, too, there was no delay, but God said immediately: “Let there be light” and light was made.¹²³³

Scripture later maintains this distinction as it speaks of four separate celestial sources. For example, in Ecclesiastes 12:2 the preacher writes: “Before the sun, and the light, and the moon, and the stars be darkened.”¹²³⁴ Notice that the sun and stars are distinguished from the “light.” The same four sources are noted again in Psalm 148:3: “Praise ye him, O sun and moon: praise him, all ye stars and light.” Thus we know that this detailed description is not merely an idiosyncrasy of only one biblical writer.

Since at the beginning of creation the Earth was surrounded by a huge mass of water, the light created subsequent to the initial 12 hours of evening on the First day would have radiated through the water on its way to the Earth’s surface.¹²³⁵ Water, then, was the first medium in

¹²³³ Briefwechsel, *Das Wahre Weltbild*, p. 22. Regarding the creation of the angels, Hildegard states that it occurred during the creation of light. She writes: “For at the first fiat, ‘let there be,’ the angels came forth...” (*ibid.*).

¹²³⁴ The Hebrew contains four separate nouns with an article for each of the four, in addition to each being separated by the *waw* conjunction, denoting in the clearest of terms that the four sources are separate and distinct. Reading from right to left:

עַד אֲשֶׁר לֹא־תִחַשֵׁךְ הַשֶּׁמֶשׁ וְהָאֹר וְהַיָּרֵחַ וְהַכּוֹכָבִים

¹²³⁵ If we assume that the primordial light was created immediately after the Earth and the water surrounding the Earth, yet “darkness” or “evening” would have transpired for 12 full hours before the light appeared on the surface of the Earth, this would allow 12 hours for the light to travel through the water to reach Earth. In other words, while the

which light traveled. Being on the outer circumference of this multi-million-mile layer of water, these primordial fires would, indeed, have been immense, much larger than our present sun, and even much larger than thousands of suns. But since the massive water beneath it would have proportionately diffused its light and heat, the Earth would have received the proper amount of radiation. As Hildegard says, the four elements of fire, earth, water, and air are kept in perfect balance, both during and after the creation week.

light is traveling through the water, the surface of the Earth is still in its 12 hours of “darkness” or “evening.” Considering that light travels two-thirds of its normal air speed in water, it would have traveled 123,000 miles per second through the primordial water. Traveling 12 hours at 123,000 mps means that the radius of the surrounding water could have been as long as 10,627,200,000 miles, which equals 1.54×10^{28} cubic miles of water volume. This is more than three times the spherical volume of our solar system.

The Sequence of Events from the First to the Fourth Day

One might ask why there were two separate light sources: one source for Days 1-3 and another source for Days 4-6. The reason is that the major portion of both the primordial light and the primordial water created on the First day are to be transported away from the Earth, a migration which happened on the Second day, when God created the firmament. After the water is sent away, it is the firmament's turn to serve as light's medium in which it can travel. As the firmament was being "stretched out"¹²³⁶ it created the fabric of space (which, as we stipulated earlier, is a rigid particulate, not a vacuum), and at the same time, took with it the fire and water to their new recesses of the outer universe, and which subsequently formed the layers of fire and water existing there in Hildegard's cosmology. Our present sun would have been too small to provide the necessary light for the day/night sequence required by the text of Genesis 1:5: "and there was evening and there was morning, one day." As we noted, the size of the sphere of water that covered the Earth on the First day was thousands of times bigger than the sun itself and therefore the sun's light could never have penetrated to the Earth in order to provide enough light to dispel the darkness.

Although the expanding firmament carried the greater portion of the light and water to outer layers of the universe, a small portion of the water remained on Earth and a portion of the fire was left above the Earth. This residual water was then used to fill the ocean and river basins on the Third day, while the residual light was confined to a hemispherical region above the Earth and rotated with the same twenty-four cycle as did the larger hemisphere of fire on the First day. On the Second and Third days, of course, much less light would be needed to illuminate the Earth since after the First day there is no longer any water surrounding the Earth to diffuse the light. As these residual fires surrounding the Earth burned out just after the second 12-hour period on the Third day, this would necessitate the creation of additional "fires" on the dawn of the Fourth day, namely the sun, in order to provide the Earth with an uninterrupted sequence of day and night. (NB: Genesis 1 keeps track of time by "evening to morning," not morning to evening).

It is more likely, however, that the residual fire or plasma circling the Earth on the Second and Third days was not exhausted (the same is true for the sun for the foreseeable future) and was thus used to form the sun on the Fourth day, a position held by a number of Church Fathers and medieval scholars.¹²³⁷ This sequence of events fits the text of

¹²³⁶ Cf. Jb 9:8; Ps 104:2; Is 42:5; 44:24; 45:12; 51:13; Jr 51:15; Zc 12:1.

¹²³⁷ Gregory of Nyssa (*Hexameron*, PG 44, 66-118); Ephrem the Syrian (*Genesim et in Exodum commentarii*, in CSCO, v. 152, p. 9); Chrysostom (*Homilies on Genesis* (PG 53, 57-58). Thomas Aquinas also held this view (*Summa Theologica*, 1, Qs. 67, Art. 4, Re. 2), as did a few other medievals: Honorius of Autun (*Hexameron* PL 172, 257); Peter Lombard (*Lombardi opera omnia*, PL 192, 651); Colonna, aka Aegidius Romanus

Genesis 1, since the size and intensity of the residual fires on the Second and Third days would have to be the same as our present sun, otherwise the Earth would not have been hospitable to the vegetation created on the Third day. The firmament, having already been created for the purpose of being a depository for the heavenly bodies, will have the sun placed in it on the Fourth day. As the firmament rotates on a twenty-four hour cycle, it will carry the sun with it, and thus the day/night sequence will be uninterrupted for the remainder of time.

(*Opus Hexaemeron*); Nicholas of Lyra (*Postillae perpetuae*); Cajetan (*Commentarii de Genesis I*), and followed by Moses Mendelssohn (*Commentary on Genesis*) Zwingli (*Werke*); Luther (*Commentary on Genesis*); Calvin (*Commentary on Genesis*); Petavius (*Dogmata theologica*) et al.

The Outer Layer of Plasma and Modern Science

The original mass of fire, however, is still at the outer recesses of the universe. Its heat is very intense, and thus we can understand why it will someday be used to destroy the inner universe. Interestingly enough, modern science may have received a glimpse of this layer, or something close to it. In December 1998 a team of international cosmologists sent up the BOOMERANG (Balloon Observation of Millimetric Extragalactic Radiation and Geophysics) telescope over Antarctica for ten days.¹²³⁸ It took pictures of the cosmic microwave background radiation as it would appear at the edge of the universe. The picture shows what looks like a mass of fire or plasma, evenly dispersed throughout the universe. As one caption described it: “In this picture, we see the distant universe as it makes its transition from a glowing 2700°C plasma to a perfectly transparent gas....BOOMERANG is the first telescope with the resolution and sensitivity required to image these...” Not surprisingly, most scientists who interpreted the picture believe in the Big Bang theory, thus they add that the plasma is from “approximately 14 billion years ago, a mere 300,000 years after the Big Bang.” Of course, since the Big Bang never occurred, this leaves the primordial plasma as a created artifact of the First day of Creation, when God said: “Let there be light.”

This conclusion is supported by the fact that the BOOMERANG’s depiction of the primordial plasma does not support the Big Bang theory. Although the world’s scientists were initially enthused by the pictures, that enthusiasm soon turned to dismay when it was discovered that the plasma contained too many unexpected anomalies. As *Scientific American* reported it:

Usually cosmology goes something like this: new observations come in, scientists are baffled, models are upended. After the dust settles, however, patches are affixed and the prevailing theory emerges largely intact. But when the measurements by the Boomerang and Maxima telescopes came in, the sequence was reversed. Scientists were elated. “The Boomerang results fit the new cosmology like a glove,” Michael S. Turner...told a press conference in April. And then the dust settled, revealing that two pillars of Big Bang theory were squarely in conflict...¹²³⁹

...follow up studies soon showed that the lingering discrepancy, taken at face value, indicates that the universe is in fact spherical....The second...suggests that the primordial

¹²³⁸ *Nature*, April 27, 2000, pp. 907-1021.

¹²³⁹ “Boomerang Effect,” *Scientific American*, July 2000, p. 14.

plasma contained surprisingly many subatomic particles....But accounting for those extra particles is no easy matter. According to Max Tegmark...the Boomerang results imply that subatomic particles account for 50 percent more mass than standard Big Bang theory predicts – a difference 23 times larger than the error bars of the theory. “There are no known ways to reconcile these measurements and predictions,” says David R. Tytler of the University of California at San Diego.¹²⁴⁰

A similar finding was found by the Goddard Space Flight Center headed by Alexander Kashlinsky. Discovering the same “strange background glow” from having “peered all the way to the most remote objects in the universe,” *Discover* writes:

Kashlinsky and his team at Goddard examined a deep-exposure image of a patch of sky taken by NASA’s orbiting Spitzer Space Telescope and then subtracted the light from all the evident stars and galaxies. What was left was a dim background glow never seen before....”We see a signal that cannot be explained by stellar populations that we know,” Kashlinsky says.¹²⁴¹

So here we see that the scientific evidence does not support the Big Bang theory; rather it supports Hildegard’s spherical universe with the hot plasma she says resides at its outer layers. According to Hildegard, the ether and water layers beneath it cool the high temperatures created by the plasma. The ether layer would serve as the initial thermal cushion to diffuse the heat, while the water layer would complete the process. As Hildegard puts it: “The outer sphere throws its fire equally on the other spheres. On the opposite side, the water sphere humidifies equally with its humidity all the other spheres,” yet she also tells us that these cosmic waters “are in their own state, different than the lower waters [on Earth].”¹²⁴² As we will see later, the cosmic water may

¹²⁴⁰ “Boomerang Effect,” *Scientific American*, July 2000, p. 15.

¹²⁴¹ Susan Kruglinski, “Hunting of the First Stars,” *Discover*, February 2006, p. 17. George F. R. Ellis recognized this same trait in inhomogeneous [Earth-centered] models of the universe, stating: “Just as in the standard universe models, the region beyond would be occupied by a hot cosmic plasma; and this could be the source of the blackbody radiation” (G. F. R. Ellis, R. Maartens and S. D. Nel, “The Expansion of the Universe,” *Monthly Notices of the Royal Astronomical Society*, 184, 1978, p. 444).

¹²⁴² *Die göttlichen Werke*, 56; *Das wahre Weltbild*, p. 84. Posch adds: “The volume of these elementary quantas of fine matter is smaller by many orders of magnitude than the atomic corpuseles, and which are invisible to our eyes. The upper waters are also invisible, as is the cosmic air and fire. The upper water is not comparable to H₂O, as the cosmic air is not comparable to our atmospheric air” (*ibid*).

be in a super-gaseous state, yet it humidifies the whole universe, and, as Hildegard adds: “The humidity and fire produce the appropriate heat to strengthen the firmament.”¹²⁴³ This exchange of the four elements, among other processes (such as the cosmic winds upon which we will elaborate later), would leave the ambient temperature of the universe as cool as the present 2.73° Kelvin, while the water nearest the fires could be as hot as 3500° Kelvin and still allow the water to survive in the form of molecules.

¹²⁴³ *Die göttlichen Werke*, 56; *Das wahre Weltbild*, p. 84.

The Purpose of the 2.73° Kelvin Temperature of the CMB

The maintenance of 2.73° Kelvin¹²⁴⁴ brings up a very significant dimension of Hildegard's cosmology. Modern science has struggled trying to understand the origin and homogeneity of the 2.73° temperature, the most popular theory being that it is the remnant of the radiation from the so-called Big Bang explosion that various scientists believe occurred 13.5 billion years ago. Others hold that it is the resulting energy from the vibration of dense particles in space; while still others believe it is the residual temperature of all the stars and galaxies in the universe.

According to Hildegard's visions, the 2.73° Kelvin is a well-designed and precise residual temperature that is used to keep the universe stable. It is the result of a cyclical thermic process occurring in the whole universe precisely so that it won't overheat. The very high density of the firmament (which we will detail momentarily) allows it to act as an ideal gas, and according to the well known formula: $P \times V/T = R$,¹²⁴⁵ the 2.73° Kelvin is the temperature needed to coordinate with the volume and pressure within a finite and closed universe. If these values were not maintained, then, as Hildegard says, the universe would "melt." We have already seen in our discussion of helium-4 that at the right Kelvin temperature (between 0.25° and 3.0° for helium-4) what we know as a gas at room temperature becomes a frictionless "supersolid" at the low end of the Kelvin scale. As we will see, Hildegard tells us the same principle is true with the firmament.

¹²⁴⁴ The Kelvin scale begins with absolute zero, below which temperatures do not exist. Absolute zero, or 0°K, corresponds to a temperature of -273.15° Celsius. Thus, a temperature of 2.73° Kelvin is very cold and very near absolute zero. The Kelvin degree is the same size as the Celsius degree. For example, the freezing point of water is 0° Celsius; the boiling point of water is 100° Celsius, which correspond to 273.15° Kelvin and 373.15° Kelvin, respectively. The Kelvin scale is named after the British mathematician and physicist William Thomson Kelvin, who invented it in 1848.

¹²⁴⁵ The behavior of an ideal gas is described by the relationship $PV = kT$ (pressure x volume = k x temperature). The proportionality constant, k, is usually expressed as the product of the number of moles, n, of the gas and a constant R, known as the universal gas constant, which has a value of 8.3149×10^3 joules/kilogram-mole-degree. The ideal gas law is simplified by replacing the ordinary volume V by the specific volume v, which is equal to V/n, which then yields the formula $Pv = RT$.

The Four Elements of the Universe

Hildegard's visions show that she understood matter to be composed of four basic elements, the same ones that Aristotle recognized: fire, air, water and earth, which Aristotle obtained from Empedocles. Tempted as we might be to dismiss these as primitive concepts or think of them as referring merely to specific physical substances (e.g., dirt, flames, oceans/rivers, wind/breath), in reality the four terms represent the general makeup of all matter. On one level of understanding, "earth" refers to solids; "water" refers to liquids; and "air" refers to gases – the three states of matter that any modern scientist would recognize. The "fire" represents energy, or what some identify as the fourth state of matter – plasma. In fact, plasma physicists consider fire to be plasma, as they do the sun, the stars, intergalactic nebulae, quasars, radiogalaxies, galaxies, auroras, lightning, the flow of electrical current in conductors and semiconductors, fluorescent lights and neon signs. Thus we have matter and energy, the two entities constituting anything physical that the universe has to offer. Even modern scientists recognize the fire-air-water-earth terminology. For example, biogeochemist Egon Degens writes:

The element air is described by molecular kinetics and statistical physics. The "simple" substance fire is thermodynamically defined as heat or energy. Quantum mechanics, solid-state physics and chemistry refer to matter rather than to Earth. The problem child, however, is water, because so far no equation can thermodynamically describe its reaction and properties at the molecular level.¹²⁴⁶

As we relate Hildegard's description of these four elements to even deeper facts from modern science, we find that the four also correspond to the fundamental building blocks of nature that we moderns have assigned such names as protons, neutrons and electrons. The "fire" is the energy of the atom, otherwise known as the electron, whereas the protons and neutrons, known as a nucleon, are the "earth" (proton) and "water" (neutron). As we will see later, the atom is also comprised of "air," which occupies the space between the "fire" of the electron and the "earth" and "water" of the nucleon. In a very similar way, Hildegard's visions show the universe is constructed with the energy zones in the outer layers; the air/water layers in the middle zones; and the earth material in the center.

Accordingly, Hildegard adds: "More or less than these four elements there is nothing."¹²⁴⁷ Scientifically speaking, we understand

¹²⁴⁶ *Universal Water: The Ancient Wisdom and Scientific Theory of Water*, Hawaii, InterOcean Publishing, 2002, p. 93.

¹²⁴⁷ *Ursachen u. Behandlung der Krankheiten*, 71, *Das wahre Weltbild*, p. 85.

this to mean that the 103+ elements of the [Periodic Chart](#) (see here for a full IUPAC [periodic table](#)) do not represent substances that have differing fundamental components. Lead, for example, is not made of lead protons and lead electrons; rather, lead has 82 protons and 82 electrons. If we take away two protons and two electrons to leave an 80-80 balance, we will have the element mercury. Take away one more proton and electron and we now have gold. The fundamental building blocks are the same; only their number and ratio change from element to element.

The cosmic spheres of fire, air, water and earth are in constant communication and exchange in order to produce the proper balance required for the universe's stability. This, we might say, is the *Ultimate Unified Field Theory*. As Hildegard puts it:

God has built the world by means of the four elements, so that no one of them may be separated from the others, for then the world would go back to nothingness if an element could exist separately from the others.¹²⁴⁸

For example, to varying degrees, fire (energy) permeates the other three elements: water, air and earth. The very formula we moderns use, $E = mc^2$, is, in Hildegardian terms, little more than the permeation of the element fire (energy) into earth (matter). As we noted above, on a macro scale astronomers have seen evidence of “fire” in the form of plasma all throughout the universe, the study of which is commonly known as plasma cosmology.¹²⁴⁹ In addition, it is fire (energy) that turns

¹²⁴⁸ *Ursachen u. Behandlung der Krankheiten*, 68, *Das wahre Weltbild*, p. 89.

¹²⁴⁹ Nobel laureate, Hannes O. G. Alfvén, “Cosmology in the Plasma Universe: An Introductory Exposition,” *IEEE Trans. Plasma Science*, Feb, 1990; “Plasma Physics from Laboratory to Cosmos – The Life and Achievements of Hannes Alfvén,” by Carl-Gunne Fälthammar, *IEEE Trans. Plasma Science*, June 1997; *World-Antiworlds: Antimatter in Cosmology*, 1966; Eric Lerner, *The Big Bang Never Happened*, Vintage Press, 1992; US Dept. of Energy advisor and Associate Director of Los Alamos National Laboratory, Anthony Peratt (A. Peratt and D. Nielsen, “Evolution of Colliding Plasmas,” *Physical Review Letters*, 44, pp. 1767-1770, 1980); Oscar Buneman in “A Tribute to Oscar Buneman – Pioneer of Plasma Simulation,” *IEEE Trans. Plasma Science*, Feb, 1994; Nobel nominee, Kristian Birkeland, in “The Worlds in the Universe,” wrote: “This theory differs from all earlier theories in that it assumes the existence of a universal directing force of electro-magnetic origin in addition to the force of gravitation, in order to explain the formation around the sun of planets (which have almost circular orbits and are almost in the same plane) of moons and rings about the planets and of spiral and annular nebulae” (*Sky and Telescope*, “Birkeland and the Electromagnetic Cosmology,” May 1985). The first to recognize the plasma state was Sir William Crookes, who discovered it in 1879, and which was later given the name “plasma” by Nobel laureate Irving Langmuir in 1929. Interestingly enough, Hildegard’s visions portray something very close to plasma cosmology for the origin of the sun’s energy and its relationship to the planets.

solids into liquids, and liquids into gases. Each state must maintain a certain energy envelope in order to remain a solid, liquid or gas. As Hildegard puts it in her scientific terms: “The water contains in itself fire...the water could not flow if it didn’t contain some fire.”¹²⁵⁰

In Hildegard’s terminology, “fire” represents many things, and we moderns have to accommodate her language to what we know scientifically. Although we speak of energy coming in the form of the entire electromagnetic spectrum – from gamma rays, to visible light, to microwaves – in Hildegard’s vision “fire” represents all of these various energy forms. As Dr. Posch has suggested, we would venture to say that Hildegard’s “fire” comes in three states, just as matter comes in solid, liquid and gaseous form. The fire we see as flames is analogous to the solid state; electrical current or light waves are analogous to the liquid state, while radiation and high-energy plasma are the gaseous state. Similar to solids, flames are confined to a certain locale. But as liquids flow, so light energy flows from one place to another. For example, a lightning bolt that descends and hits the ground will suddenly burst into flames, and in such cases one could say that the liquid form of energy was turned into a solid form. We also know that light can penetrate its medium only so far, for opaque substances will deter it, whereas radiation, like a fine gas, can penetrate through various surroundings. Radiation also produces heat, and thus makes it similar to a flame. In fact, there is so much “fire” in the element radium that it literally overflows with radiation. In the words of Marie Curie, the discoverer of radium:

A glass vessel containing radium spontaneously charges itself with electricity....Radium possesses the remarkable property of liberating heat spontaneously and continuously. A solid salt of radium develops a quantity of heat such that for each gram of radium contained in the salt there is an emission of one hundred calories per hour. Expressed differently, radium can melt in an hour its weight in ice. When we reflect that radium acts in this manner continuously, we are amazed at the amount of heat produced, for it can be explained by no known chemical reaction. The radium remains apparently unchanged....As a result of its emission of heat, radium always possesses a higher temperature than its surroundings....When a solution of a radium salt is placed in a closed vessel, the radioactivity in part leaves the solution and distributes itself through the vessel, the walls of which become radioactive and luminous...We may assume, with Mr. Rutherford, that radium emits a radioactive gas and that this spreads through the surrounding air and over the surface of neighboring objects. This gas has received the

¹²⁵⁰ *Ursachen u. Behandlung der Krankheiten*, 68, *Das wahre Weltbild*, p. 89.

name emanation. It differs from ordinary gas in the fact that it gradually disappears.¹²⁵¹

Another important relationship among the four elements is the affinity of fire and earth, on the one hand, and air and water on the other hand. As we noted earlier, one example of the former relationship is that as “fire” represents the electron, the “earth” represents the proton. These two substances each carry a charge and thus relate to each other electrically or electromagnetically. All communication flows from positive to negative and back again. In another way, light is invisible unless it reacts with matter. We cannot see a light beam until some solid object impedes it, and this is one reason why the night sky is so dark. It is different for air and water. The communication between their domains consists largely of mechanical waves, incorporating pressure and temperature and other motions.

Upon these four elements and their communicative principles is based the workings of the whole universe. It is really quite simple. Modern science assigns various values and proportions to these entities and their relationships, such as Planck’s constant, Boltzmann’s constant, Avogadro’s constant, the Gravitational constant, the electron charge value, etc., but they are all essentially describing the four basic elements of Aristotelian science and how they interact with one another.

¹²⁵¹ “Radium and Radioactivity,” Mme. Sklodowska Curie, *Century Magazine*, January 1904, pp. 461-466. The “gas” is now known as radon.

The Rotation of the Firmament

As we have indicated the point earlier in this volume, the form and substance of the biblical “firmament” is particulate. Although its discovery has eluded both biblical scholars and scientists, some, like St. Augustine, never doubted its existence. As he once said in his famous book *The Literal Meaning of Genesis*: “...we must not doubt that it does exist in that place. The authority of Scripture in this matter is greater than all human ingenuity.”¹²⁵² This is the consistent testimony of the patristic era, and it is a haunting voice against modern scholars who have given up the hope of finding the firmament, thus forcing them to declare that “Augustine’s search for the firmament should seem baffling.”¹²⁵³ Unlike many modern scholars who have accepted Copernican cosmology with its attendant Big Bang origins, the Fathers were faithful to the biblical text, no matter how difficult it was to understand from their limited science. The medievals who followed them adhered with the same tenacity to the literal words of Scripture. As such, the Creator did not leave us in the dark regarding the correct understanding of Holy Writ.

As we noted earlier, geometrically speaking, there is no relative difference between a rotating universe around a fixed Earth and a rotating Earth in a fixed universe. They are, indeed, mirror images of one another. But there is only one true reality. As such, only one cosmology can be correct. In Hildegard’s visions, it is the firmament that rotates, not the Earth, and this fundamental fact is mentioned many times in her description of the universe. As Helmut Posch notes it:

This true world-view is no invention of mine. It is the result of Hildegard’s statements. So that every reader may see this for himself, in what follows let me quote those statements which are of decisive import for the world view....All this detailed physical knowledge far exceeds our present-day knowledge. Only someone who knows how the universe is really designed can speak like this. Since Hildegard was not a genius but a simple woman, all this knowledge can only arise from instructions of the Omniscient One.”¹²⁵⁴

Accordingly, Hildegard writes:

¹²⁵² *The Literal Meaning of Genesis*, Book 2, Chapter 5, Number 9. Aquinas adds: “Whether, then, we understand by the firmament the starry heaven, or the cloudy region of the air, it is true to say that it divides the waters from the waters...” *Summa Theologica*, Book 1, Question 68, Article 3.

¹²⁵³ Stanley Jaki, *Bible and Science*, p. 95.

¹²⁵⁴ *Das wahre Weltbild*, pp. 119, 121.

And further I saw the world vault, through powerful drifts of the east and the south winds with their crosswinds, allowing it to circulate over the Earth from east to west, and there the west wind and the north wind caught it together with its crosswinds and tossed it underneath the Earth back from west to east.¹²⁵⁵

Posch gives us the meaning of her words:

According to this, the entire universe is put in motion by the cosmic winds. They supply the unimaginable propulsion energies for the rotation of the firmament. Observed from the north, the firmament rotates equatorially and clockwise from east to west. Not a single heavenly body moves by its own power. All of the kinetic propulsion energy flows entirely from the stationary-positioned winds. Without these winds the entire universe would be completely without gravity, weightless like thoughts.... Even the largest stars would not weigh a gram because mass without the wind energy flowing through it would contain no gravity-forming power...Mass and energy only appear to be equivalent. At close observation, energy is an interaction between matter and the winds.¹²⁵⁶

Thus, the entire universe rotates 360° per day, moving clockwise, or east to west, from the position of one standing at the North Pole. To reinforce the picture Posch adds: “Therefore, geostationary satellites travel against the rotation of space in order to appear stationary [to us].” We also see that the phenomenon of inertia in the cosmos is not due to some mysterious property of matter (that modern science has yet to explain), but is merely the result of cosmic winds pushing the firmament and its heavenly bodies in the designated direction. In this system, as Posch notes: “Thus it has been clarified physically why the sun, with its enormous mass, can move around the little spot of Earth. According to the current law of gravity, there would be no explanation for this.”¹²⁵⁷ Hildegard’s vision thus adds a deeper understanding to the mundane meaning often assigned to the winds of Ecclesiastes 1:4-6:

A generation goes, and a generation comes, but the Earth remains forever. The sun rises and the sun goes down, and hastens to the place where it rises. The wind blows to the south, and goes round to the north; round and round goes the wind, and on its circuits the wind returns.

¹²⁵⁵ *Das wahre Weltbild*, p. 113.

¹²⁵⁶ *Das wahre Weltbild*, pp. 113-114.

¹²⁵⁷ *Das wahre Weltbild*, p. 120. Note: Posch is referring strictly to the Newtonian explanation for gravity, an explanation that does not take into account the Machian view that the whole universe is involved in the forces experienced by our solar system.

Moreover, because “the Earth remains forever,” Hildegard’s visions see a real “up” and “down” to the universe, which is due to the immobility and permanence of the Earth from which all other movements in the universe are measured. She writes:

For the sun, God has determined that it should shine above the Earth and hide under the Earth. That’s why during the day it shines on the Earth, just as a man lives watchfully with open eyes during the day; at night, however, it moves beneath the Earth, just as a man sleeps with his eyes closed at night.¹²⁵⁸

¹²⁵⁸ *Welt und Mensch*, p. 164; *Das wahre Weltbild*, p. 120.

The Local Cosmic Counter-Current

In addition to the rotation of the firmament by the force of the cosmic winds, Hildegard sees a local counter-current in her vision. She writes:

Also I saw: in the upper fire of splendor there appeared a circle that girded the entire firmament from east to west. From there a wind forced the planets to go from west to east against the rotating direction of the firmament. However, it did not send out its blows toward the Earth, like the other winds, but only moderated the course of the planets, as we said before already...The firmament rotates speedily, and the sun, together with the other planets, slowly moves towards it in the opposite direction and hampers its velocity.

For if the sun did not impede the firmament by its resistance to it, or if it ran counter to the firmament even with the other planets and with the same velocity with which it revolves, everything would be mixed up and the entire firmament would burst asunder. For if the firmament were immovable so that it would not revolve, then the sun would be above the Earth almost throughout the entire summer, without it becoming night, and almost during the entire winter under the Earth, without it being day.

Now, however, the firmament revolves in such a manner that it moves counter to the sun, and the sun counter to it, for which reason the firmament compresses itself through the heat of the sun and is made more resistant all the more quickly, that is to say: when the sun traverses the firmament and wholly penetrates it and pours through it with its fire.¹²⁵⁹

So we have a counter-clockwise current that is moving the entire solar progeny from west to east against the clockwise movement of the firmament from east to west. As Posch sees it: "This relative movement is the actual centerpiece of Hildegard's celestial mechanics." The sun, which carries the planets, is moving ever so slowly against the rotating firmament due to the presence of a local cosmic wind. We can readily see the physical results of these motions and counter-motions. For example, the local motion of the sun against the firmament causes the sun to retard in its movement with respect to the Earth and the stars by about 1° of arc per day. This will cause a difference in the amount of time the stars, which are stationary inside the firmament, revolve with the firmament around the Earth, as opposed to the time the sun and the

¹²⁵⁹ *Das wahre Weltbild*, p. 116; *Ursachen u. Behandlung der Krankheiten*, 24 in *Das wahre Weltbild*, pp. 120-121.

planets revolve around the Earth. The difference between the two is commonly known as the “sidereal day” as opposed to the “solar day.” The sidereal day is 23 hours and 56 minutes. The solar day is 24 hours. Thus, the sun needs 4 minutes more to complete its revolution around the Earth, which is due, as Hildegard’s vision tell us, to the fact that it is being slightly retarded by the cosmic winds in the firmament.¹²⁶⁰ The lag of the sun by 4 minutes each day will make the sun appear to travel through the 12 stations of the Zodiac each and every year.

¹²⁶⁰ In the heliocentric explanation, the extra four minutes is said to be due to the Earth revolving around the sun, wherein the Earth must rotate 361° per day rather than 360° in order for the sun and stars to line up with the same point on the Earth each day. We might add that Hildegard’s cosmic wind may find its evidence in the modern science’s claim that the solar system is moving in the direction of various constellations (e.g., Draco, Hercules, et al). By Mach’s principle, it may just as well be that the solar system is fixed and the ether wind is moving against it.

The Force that Moves the Planets

There is something even more significant about the solar wind. It is strongest nearest the sun and weakest at the planet Pluto. It can be thought of as a cyclone-like whirlwind or solar eddy within the larger circular current that pushes the firmament. As in a natural eddy, the angular velocity is fastest near the center. Hence, those planets nearest to the sun will revolve faster than those farther away.

Not having any suitable mechanical reason for the various speeds of revolving planets, modern science is limited to explaining this phenomenon mathematically by the formula $F = ma$, or $a = v^2/r$, wherein a planet that is revolving around the sun is said to be accelerating, while the force of its movement is the rate of acceleration multiplied by the mass of the planet. At the same time, the planet is said to be pulled into the sun and the strength of the attraction is represented by the formula $F = Gm_1m_2/r^2$, wherein the mass of the sun and planet are multiplied with a gravitational constant G (determined in the laboratory by measuring the force of attraction between two small objects), divided by the distance squared between the sun and the planet. This is commonly known as the Inverse Square Law. The balance between $F = ma$ and $F = Gm_1m_2/r^2$ is said to keep the planet on its circular path so that it neither falls into the sun nor flies off into outer space. The problem with these formulas, however, is that they do not explain what, precisely, is the nature of the attracting force between the sun and the planet, nor do they explain why a planet has continual acceleration. It is similar to watching the dial on a scale calibrate the weight of an object without being able to see the object that is placed on the scale. The object could be an animal, mineral or vegetable, but we could never know by merely observing the scale's dial. Analogously, modern science has no physical explanation for gravity or inertia. They merely 'watch the dial,' as it were, and compute the result with mathematical formulas.

Moreover, as we noted earlier in remarks about Newton, the much-ballyhooed 'inverse square law' is not really as stupendous as it is claimed to be, for it is simply a natural geometric phenomenon. The inverse square law applies not only to the decrease in the force of gravity with increase in distance, but of practically any substance that can travel away from its source at a constant angle of dispersion. For example, one could obtain the inverse square law from an action as simple as measuring the amount of paint dispersed from the nozzle of a can of spray paint. The density of the paint sprayed will be inversely proportional to the square of the distance at which the paint ends up from the nozzle. In other words, the inverse square law is based on a simple law of geometry, and has nothing to do with the nature of gravity, per se. Anything that radiates away from the source at a constant angle (e.g., gravity, electricity, sound, force, light, gas density, charge) will follow the inverse square law, for at greater distances from the source, that

which is dispersed must cover an increasing area and volume, and if it is distributed evenly in that larger volume, its density will decrease proportionately, by a rate that is the inverse to the square of the distance.¹²⁶¹

As we can see, the Hildegardian model exceeds the Newtonian system. Hildegard gives us a physical reason for gravity, inertia and the combined movements of the constituents of the universe. Pluto moves slower than Mercury because Pluto is farther away from the vortex of the solar wind that pushes the planets. Near the sun the speed of the vortex is at its fastest, and this increased velocity, as Posch interprets Hildegard, “is necessary in order to carry the enormous heat away from the sun, otherwise the sun would become too hot and scorch everything on Earth.”¹²⁶² In other words, the circulating current acts as a giant fan to radiate the proper amount of heat from the sun to the planets.

From Hildegard’s vision, Posch further explains the nature of the current:

The counter-rotating wind current is narrow, like a belt. We should imagine the current as a disk-shaped rotating field in which the planets and the sun are carried. The planets, in fact, revolve on a plane, namely the ecliptic plane. This plane is unstable. It gyrates, and does so within a constant angle of 23.5°, forming a complete precessional movement around its fixed point, Earth, in one year. The Earth is the center of rotation for both the rotation of space and the point of intersection for the precessing counter-rotation of the ecliptic plane.¹²⁶³

¹²⁶¹ This rule does not apply to plasma and magnetism, however, due to the internal workings of their specific properties.

¹²⁶² *Das wahre Weltbild*, p. 117. Since the period of the planet will be proportional to its distance from the center of the vortex, the vortex nearest to the sun is traveling very fast. Posch holds that within 1.5 kilometers the vortex is moving at the speed of light. At 3 million kilometers it is moving at 210.66 km/sec, and at Mercury, which is 57.9 million kilometers, it is moving at 47.94 km/sec, which is equal to the orbital speed of Mercury around the sun. These values are reached by dividing the constant 364.87 by the square root of the distance (*ibid.*, pp. 130-131).

¹²⁶³ *Das wahre Weltbild*, p. 117.

The Cause of the Four Seasons

Here we have the explanation for the four seasons. The seasons are not caused by an Earth that is tilted 23.5° toward the North Star, but by the swaying movement of the ecliptic (that is, the path of the sun through the zodiac) as it changes the plane of its orbit by 23.5° every six months. The plane of the sun's path will precess up and down by 23.5° just as a spinning gyroscope wobbles up and down. The total amount that the sun's plane moves against the Earth's equator is 47.0° per year, or 0.2568° per day. (See enclosed CD animation for a demonstration).

If this is true, then what force is making the sun's plane of orbit change? This force, Hildegard's vision reveals, comes from the same counter-current described above. She writes:

The sun emerges as the largest planet; it heats up the firmament and its fire and strengthens it, and with its radiance it illuminates the Earth...By means of the strength of the revolution of the firmament the sun is driven in a slanted orbit from east to west through the south, even though in its journey it makes an effort to move counter to the motion of the firmament.¹²⁶⁴

Hence, as the countercurrent moves against the firmament's current, it creates an eddy of force around the sun. This force pushes the sun up and down within the margin of 47.0° each year. As Posch describes the force of the solar eddy: "The effect resembles kite-flying. If you walk against the wind with the kite, it goes up in a slanted manner."

¹²⁶⁴ *Die göttlichen Werke* 96, 100; *Das wahre Weltbild*, p. 119.

The Universe Flips Over

As the firmament rotates, Hildegard's visions show another dimension of its action:

Further I saw the south wind with its side winds, starting the day of the winter solstice, gradually lift the primordial vault from south towards north, supporting both, as it were, until the summer solstice....From the same day onward, when the days start to become shorter, the north wind with its side winds, eschewing the sunlight, pushes this vault from north to south, until, the days getting longer, the time has once again come for the south wind to push it back up.¹²⁶⁵

This is most amazing. Hildegard is telling us that the whole universe is flipped over every six months. The flipping occurs between the north and south poles of the universe. The side of the universe that was nearest the north region is, six months later, nearest to the south region, and vice-versa six months later. The slow flip is caused by the universal winds. The universal south wind pushes the south universal pole toward the north; while the universal north wind pushes north universal pole toward the south. Later we will see precisely how these cosmic winds are able to push the universe.

Here is another interesting facet to Hildegard's cosmology. In her vision the north and south poles of the Earth do not lie in a vertical direction but horizontal. Thus, the universe rotates daily around the north-south pole like chicken on a rotisserie or a wheel rotating on an axle, and which axle is slowly reversed on a semi-annual schedule. The horizontal position of the north-south axle will allow the four compass points to form a horizontal plane, which then explains why Scripture sometimes refers to the "four corners of the Earth." A square with a corner positioned at each of the compass points is horizontally circumscribed in a sphere.¹²⁶⁶ Another means of compensating for Scripture's language is that the "corners" are the tips of the four hemispherical cones that converge at the center of the Earth.

Modern cosmologists seem to have found recent evidence for the twisting or flipping of the universe. In 1997 physicists Borge Nodland and John Ralston discovered that radio waves traveling through space rotated the plane of their polarization.¹²⁶⁷ C. Wolf believes this

¹²⁶⁵ *Das wahre Weltbild*, p. 119.

¹²⁶⁶ Is 11:12; Ap 7:1; 20:8.

¹²⁶⁷ "Indication of Anisotropy in Electromagnetic Propagation Over Cosmological Distances," *Physical Review Letters* 78, 16: 3043-3046, April 21, 1997. For a selected data set, the axis they found had a declination and right ascension of $(d, a) = (0^\circ \pm 20^\circ, 21^h \pm 2^h)$, within 45° of the "opposite" pole. The statistical probability that the two axes are only accidentally within 45° of each other is not negligible. Ralston and

phenomenon to be of such importance that it may force “modifications to particle theory and cosmology” and “possible alterations of fundamental physical theory...in the future.”¹²⁶⁸ Even though Nodland and Ralston’s rotation was small (one period of polarization rotation completed in about ten billion years), they could be measuring merely the slight differences in Hildegard’s semi-annual universe rotation. In other words, the universe’s polar rotation is so precise that the finest instruments detect only a one in 10^{10} variation. Whatever the correct application, the news of rotating electromagnetic waves was not well received from the science community, since it would automatically deny Einstein’s cherished theory of General Relativity that claims there is no center or distinction in the universe.

The reason the universe must make this annual 180° change is that its constant daily rotation in one direction (east to west) causes an increasing momentum, which, if there were no compensating factor, would begin to deform the universe’s spherical shape. The universe would become elongated and eventually break into two or more pieces. As Hildegard puts it:

For if the sun did not impede the firmament by its resistance to it, or if it ran counter to the firmament even with the other planets and with the same velocity with which it rotates, everything would be mixed up and the entire firmament would burst asunder. For if the firmament were immovable so that it would not rotate, then the sun would be above the Earth almost throughout the entire summer, without it becoming night, and almost during the entire winter under the Earth, without it being day.

Now, however, the firmament rotates in such a manner that it moves counter to the sun...for which reason the firmament compresses itself through the heat of the sun and is made more resistant all the more quickly, that is to say: when the sun traverses the firmament and wholly penetrates it and pours through it with its fire.¹²⁶⁹

Nodland added that the twisting of the waves increased the more it receded further into the universe, suggesting that the rotation was a truly universal phenomenon. They also pointed out that the rotation was specific to the direction one looked. It twisted right if one looked in one direction, but left if one looked in the opposite direction. In 1982, Paul Birch was the first to report the basis for such a phenomenon when he observed a correlation of the polarization angle with the source location angle relative to a preferred axis in the universe (*Nature*, London, 298, 451, 1982). Kendall and Young confirmed Birch’s results two years later (D. Kendall and G. A. Young, *Monthly Notices of the Royal Astronomical Society*, 207, 637, 1984), as did Beintenholtz and Kronbert (M. Beintenholtz and P. Kronberg, *Astrophysics J*, LI, 287, 1984).

¹²⁶⁸ C. Wolf in “Polarization Rotation Over Cosmological Distances as a Probe to New Physics,” *Aperion*, Vol. 8, No. 3, July 2001, p. 95.

The Behavior of Man and the Reaction of the Cosmos

In Hildegard's next series of statements, she reveals one part of the interconnection between the events in the cosmos and the behavior of mankind. After the fall of man in Eden, nature was altered or damaged in various ways. Death entered the world, animals became fearful of men, the ground produced thorns and thistles, and the whole universe was made subject to gradual deterioration.¹²⁷⁰ Hildegard tells us that the same is true with the firmament:

Before the fall of Adam the firmament was immovable and did not rotate. After his fall, however, it started to move and to revolve. From the Last Day onward, however, it will again stand still as it was on the first day of creation and before Adam's fall.¹²⁷¹

This means that the light of the first three days of creation, and, after that, the sun and stars of the Fourth day up until the sin of Adam, were revolving around the Earth without being carried by the firmament. Apparently, the firmament was in a pristine condition prior to the Fall and this condition changed drastically afterwards. As it stands now, unless the firmament rotates it will become unstable and disintegrate. As Hildegard puts it:

Now, however, it rotates so that it will receive its power from the sun, the moon and the stars, because, if it stood still, it would become liquefied and weakened, melting in a short time.¹²⁷²

The firmament is subservient and compliant with the shiners [stars] for the benefit of the Earth, and serves the Earth, as the fire stabilizes it [the firmament], the air restrains it, and the

¹²⁶⁹ *Ursachen u. Behandlung der Krankheiten*, 24, *Das wahre Weltbild*, p. 121.

¹²⁷⁰ Cf. Gn 3:17-19; Jr 12:4; Rm 8: 19-22; Ac 3:21.

¹²⁷¹ *Ursachen u. Behandlung der Krankheiten*, 24, *Das wahre Weltbild*, p. 121.

¹²⁷² *Ursachen u. Behandlung der Krankheiten*, 24, *Das wahre Weltbild*, p. 121. The condition of the firmament may have also affected the speed of light. In the more ideal condition prior to the Fall, the speed of light through the firmament would have been much faster, which would help account for the fact that starlight would have appeared on Earth on the fourth day of creation, otherwise, in contradiction to Genesis 1:14-19, they could not have been used as timekeepers (e.g., sidereal time) by the patriarchs. Since light travels faster or slower depending on the medium, there is no scientific anomaly in the above scenario.

water dashes it; the firmament performs as one who serves and the Earth stands as someone who is seated and ruling.¹²⁷³

According to Posch's interpretation of Hildegard:

Through its [the firmament's] rotation, the elements are purified; otherwise we would have suffocated in the world's stench long ago. The elements interact with the cosmic elements, as we know by now, and are constantly "filtered" and "distilled" thereby.¹²⁷⁴

¹²⁷³ *Berliner Fragmente*, 38, *Das wahre Weltbild*, p. 131.

¹²⁷⁴ *Das wahre Weltbild*, p. 132.

The Constitution of the Firmament

Our present knowledge of science may also confirm what Hildegard's vision reveals about the firmament. Very special factors are necessary to have such a versatile and undetectable medium permeate the entire universe. Notably, this subject is approached, albeit indirectly, by one of the world's most respected physicists, John A. Wheeler, professor emeritus of Princeton University and co-author of the most comprehensive book written on gravitation to date. In an article he wrote with C. M. Patton titled: "Is Physics Legislated by Cosmology?" Wheeler, interestingly enough, begins with an offhand comment about the first two days of Genesis. He writes:

No one sees any longer how to defend the view that 'geometry was created on Day One of creation, and quantized on Day Two. More reasonable today would appear the contrary view, that 'the advent of the quantum principle marked Day One, and out of the quantum principle geometry and particles were both somehow built on Day Two.¹²⁷⁵

In a simplified way we can summarize Wheeler's concern by noting that his remarks show that physics has wrestled with the proverbial problem of the chicken and the egg. Which came first, the chicken (geometry) or the egg (the composition of the universe that allows geometry and, even more basic, the concept of extension)? Technically speaking, an *ex nihilo* understanding of Day One and Day Two would have no such concern, since things are merely called into being by divine fiat and made to work with whatever material is present on the respective Days of creation. Nevertheless, Wheeler's point about the "quantum principle" does not go unappreciated by an *ex nihiloist*, for the point of his remark is that the "geometry" of the cosmos has a substratum which is defined by the principles of quantum mechanics, and which thus allows for the phenomena of extension and collapse. As Wheeler puts it:

The black hole, as "experimental model" for gravitational collapse, brings us back full-circle to the paradox that continually confronts us, and all science, the paradox of big bang and gravitational collapse of the Universe itself. The existence of these two levels of collapse reminds us, however, that theory gives us also what is in effect a third level of collapse, small-scale quantum fluctuations in the geometry of space taking place and being undone, all the time and everywhere.¹²⁷⁶

¹²⁷⁵ J. A. Wheeler and C. M. Patton, "Is Physics Legislated by Cosmology," in *The Encyclopedia of Ignorance*, eds., Ronald Duncan and Mirand Weston-Smith, New York, Pergamon Press, 1977, p. 22.

We, of course, are only interested in Wheeler's "third level of collapse," since it relates directly to the constitution of the firmament of Day Two, or what Wheeler sees as the means by which the "...quantum principles of geometry and particles were...built." In this regard, Wheeler states:

Among all the great developments in physics since World War II, there has been no more impressive advance in theory than the analysis of the fluctuations that take place all the time and everywhere in the electromagnetic field. There has been no more brilliant triumph of experimental physics than the precision measurement of the effect of these fluctuations on the energy levels of the hydrogen atom....These developments tell us immediately that the electron in its travels in a hydrogenic atom is subject not only to the field Ze/r^2 of the nucleus, but also to a fluctuation field that has nothing directly to do with the atom, being a property of all space.¹²⁷⁷

In other words, the electron not only has to interact with the nucleus, but with the field of space between the nucleus and the electron, yet a field that "has nothing to do with the atom" itself, but is a property of the independent existence of something other than the atom. So, we have protons, neutrons, electrons and an undefined but experimentally proven "field" which constitutes the fabric "of all space." We will see shortly that Wheeler's explanation is precisely what Hildegard's visions tell us of the constitution of the universe and the physical cause for gravity, nearly one thousand years before "the great developments in physics since World War II"! The only difference is that, whereas Wheeler sees "changes in connectivity with 'handles' and 'wormholes' in the geometry all the time and everywhere forming and disappearing, forming and disappearing ('foam-like structure of space'),"¹²⁷⁸ Hildegard's visions tell us that the "foam-like structure of space" is permanent and non-fluctuating. It doesn't "disappear" into "other universes" and come back a split second later. It is here to stay because it was made, *ex nihilo*, on Day Two, and which we call the Firmament.

Wheeler goes on to explain the dimensions and magnitude of this "field...of all space...is the Planck length,"¹²⁷⁹ which is what we have

¹²⁷⁶ J. A. Wheeler and C. M. Patton, "Is Physics Legislated by Cosmology," in *The Encyclopedia of Ignorance*, eds., Ronald Duncan and Mirand Weston-Smith, New York, Pergamon Press, 1977, p. 24.

¹²⁷⁷ "Is Physics Legislated by Cosmology?" p. 24.

¹²⁷⁸ "Is Physics Legislated by Cosmology?" p. 25.

¹²⁷⁹ "In a region of observation of dimension L the calculated fluctuation field is of the order, $\Delta\varepsilon \sim (hc)^{1/2}/L^2$... The consideration of principle that give one in electrodynamics

been arguing as one of the basic constituents and dimensions of the firmament's granularity. He continues:

One who had never heard of electricity, looking for evidence of this multiple connectivity of space, would *predict* electricity as [a] consequence of it. Thereupon *finding* electricity in nature, he would take this discovery as evidence that space really is multiply connected in the small. Nothing prevents our rising above the accidents of history to take the same position.¹²⁸⁰

These fluctuations charges are not a property of elementary particles. The relevant scale of distances is twenty orders of magnitude less than nuclear dimensions. The charges are not quantized in magnitude. The charges occur everywhere, not only where there is a particle.¹²⁸¹

The view that large fluctuations go on at small distances puts physics in a new perspective. The density of mass-energy associated with a particle...is as unimportant compared to the calculated effective density of mass-energy of vacuum fluctuations down to the Planck scale of lengths... 10^{94} g/cm³...as the density of a cloud, $\sim 10^{-6}$ g/cm³, is unimportant compared to the density of the sky, $\sim 10^{-3}$ g/cm³...the proper starting point in dealing with physics...is the sky, not the cloud...no theory of particles that deals only with particles will ever explain particles.¹²⁸²

Not only do we have Wheeler admitting that science gives us no answer for the origin of electricity (something Hildegard has answered by saying it is a form of plasma), we have him describing the basic constituents of Hildegard's firmament. Our quest now is to show how Hildegard's vision of the firmament "melting" if it did not rotate is true

the fluctuation formula [$\Delta\varepsilon \sim (hc)^{1/2}/L^2$] tell one that in geometrodynamics, in a probe region of extension L , the quantum fluctuations in the normal metric coefficients $-1, 1, 1, 1$ are of the order, $\Delta g \sim L^*/L$. Here $L^* = (hG/c^3)^{1/2} = 1.6 \times 10^{-33}$ cm is the Planck length. These fluctuations are negligible at the scale of length, L , of atoms, nuclei, and elementary particles, as the wave-induced fluctuations in the level of the ocean appear negligible to an aviator flying 10 km above it. As he comes closer, or as L diminishes, the fluctuations become more impressive. Finally, when the regions of analysis is of the order of the Planck length itself, the predicted fluctuations are of the order $\delta g \sim 1$."

¹²⁸⁰ Concluding with: "Accordingly we are led to think of space as having a kind of fluctuating foam-like structure, with everywhere positive and negative charges of order $q \sim (hc)^{1/2} \sim 10e$ continually being created and annihilated."

¹²⁸¹ "Is Physics Legislated by Cosmology?" p. 26.

¹²⁸² "Is Physics Legislated by Cosmology?" p. 27. In his arrival at the density of the substratum of 10^{94} g/cm³, Wheeler uses the equation $\rho \sim [(hc/L^*)/c^2]/L^{*3} \sim M^*/L^{*3} \equiv 2.2 \times 10^{-5} \text{ g}/(1.6 \times 10^{-33} \text{ cm})^3 \sim 10^{94} \text{ g/cm}^3$.

in scientific terms. [Gerardus Bouw](#) has done the most productive work in this area. Using Wheeler's equation,¹²⁸³ Bouw writes:

The *Planck density*, as this density is called, is today regarded as due to fluctuations in a vacuum caused by the uncertainty principle. Because of this, some have looked to this density as an explanation of the origin of the big-bang, assuming that the latter started at that density. But if the universe started at the Planck density, then it would also have to start at the Planck length and then the total mass of the universe would only be of the order of 10^{-5} grams. Furthermore, there is nothing vacuous about the firmament and so it is more logical to assume this to be a pervasive density which on sub-nuclear scales the universe can only suspect; but of whose existence it can never be certain. This, then is the density of the firmament.¹²⁸⁴

Obviously, if the firmament has such a tremendous density (10^{94} g/cm³) one wonders how anything could move through it. A mere teaspoon full would weigh hundreds of millions of tons. As we noted earlier, however, science itself has found the answer since the discovery in 1923 of deBroglie waves. Material objects, from things as small as the electron to as large as stars, move in wave motion through the firmament.

Since the firmament is rotating, this will create a centrifugal force. Hence, to remain stable, the firmament will require an equal and opposite force to keep it from disrupting. Or, perhaps a better way to phrase it is by Hildegard's description: "if it stood still, it would become liquefied and weakened, melting in a short time."¹²⁸⁵ This opposite force will come from the universal winds that blow inward and create a ubiquitous pressure (the force which we understand as gravity) to keep the firmament from radiating outward, as well as the internal cohesion of the firmament itself that holds it together. If one of the fundamental substrates of the firmament is in the Planck dimensions, then a certain rotation period will be required to compensate for the inward pressure (gravity). The amount of centrifugal force created by the rotation will not equal the inward pressure; otherwise there would be no gravity. Rather, the rotation will be just enough to allow a residual inward pressure in order to give us the strength of gravity we see today. The rate of rotation required of the firmament to reach this equilibrium is approximately 24 hours, which means it will turn 4.166×10^{-3} degrees per second, or $7.27 \times$

¹²⁸³ $\rho \sim [(hc/L^*)/c^2]/L^{*3} \sim M^*/L^{*3} \equiv 2.2 \times 10^{-5} \text{ g}/(1.6 \times 10^{-33} \text{ cm})^3 \sim 10^{94} \text{ g/cm}^3$.

¹²⁸⁴ *Bulletin of the Tychonian Society*, No 43, 1987, p. 17. In a related series of equations, Bouw finds that the energy flux of the firmament is 3×10^{125} ergs/cm²/sec.

¹²⁸⁵ *Ursachen u. Behandlung der Krankheiten*, 24, *Das wahre Weltbild*, p. 121.

10^{-5} radians per second. Since the centrifugal and centripetal forces are balanced in favor of gravity in the rotating firmament, then the firmament's angular momentum should be proportional to the gravitational constant (G), the density (ρ) and the mass (M).

A similar discovery in physics may help us understand how the rotation of the universe helps keep it stable. In the book, *The Ether of Space*, after speaking about the tremendous elasticity and density of the ether as an “incompressible,” “perfectly frictionless inviscid fluid,” and “a perfect continuum, an absolute plenum,”¹²⁸⁶ [Sir Oliver Lodge](#) states the following:

But we must go on to ask, To what is this rigidity due? If the ether does not consist of parts, and if it is fluid, how can it possess the rigidity appropriate to a solid, so as to transmit transverse waves? To answer this we must fall back upon Lord Kelvin's kinetic theory of elasticity: that it must be due to rotational motion – intimate fine-grained motion throughout the whole ethereal region – motion not of the nature of locomotion, but circulation in closed curves, returning upon itself – vortex motion of a kind far more finely grained than any waves of light or any atomic or even electronic structure.¹²⁸⁷

Lodge, of course, did not believe that the universe rotated around the Earth. He made the same mistake that all other scientists made when interpreting the Michelson-Morley experiment. Several times in his book Lodge refers to the Earth moving “nineteen miles a second” around the sun as his basis for interpreting the famous interferometer experiment.¹²⁸⁸ Thus, the “rotation” to which Lodge refers here is to the vortex motion of the ether itself, but according to Kelvin's kinetic theory, the required rotation could just as well be satisfied by a rotating universe.

Lodge makes further comments regarding ether, matter and rotation:

The Essential distinction between matter and ether is that matter moves, in the sense that it has the property of locomotion and can effect impact and bombardment; while ether is strained, and has the property of exerting stress and recoil. All potential energy exists in the ether. It may vibrate, and it may rotate, but as regards locomotion it is stationary –

¹²⁸⁶ Sir Oliver Lodge, *The Ether of Space*, New York and London, Harper and Brothers, 1909, pp. 47, 90, 95.

¹²⁸⁷ *The Ether of Space*, pp. 102-103.

¹²⁸⁸ *The Ether of Space*, pp. 55, 58, 61, 63, 66, 68.

the most stationary body we know: absolutely stationary, so to speak; our standard of rest.¹²⁸⁹

Here, of course, we see that, identical to Lorentz and other physicists of this day, the ether was understood to be stationary while the Earth moved “nineteen miles per second” through it, which is why they were all so disconcerted when the Michelson-Morley experiment did not to detect any such movement. Instead of having the Earth as their “standard of rest,” they chose a stationary ether. Still, they possessed the scientific intuition that space contained a medium, and their quest was to understand the nature of that medium. They reasoned that it remained stable because of its rotation, which rotation allowed this “frictionless fluid” to also act as a solid. Lodge elaborates as follows:

But now comes the question, How is it possible for matter to be composed of ether? How is it possible for a solid to be made out of fluid? A solid possesses the properties of rigidity, impenetrability, elasticity, and such like; how can these be imitated by a perfect fluid such as the ether must be?

The answer is, They can be imitated by a fluid in motion; a statement which we make with confidence as the result of a great part of Lord Kelvin’s work. It may be illustrated by a few experiments. A wheel of spokes, transparent or permeable when stationary, becomes opaque when revolving, so that a ball thrown against it does not go through, but rebounds. The motion only affects permeability to matter; transparency to light is unaffected. A silk cord hanging from a pulley becomes rigid and viscous when put into rapid motion...A flexible chain, set spinning, can stand up on end while the motion continues. A jet of water at sufficient speed can be struck with a hammer, and resists being cut with a sword. A spinning disk of paper becomes elastic like flexible metal, and can act like a circular saw.¹²⁹⁰

Of course, the remaining question for Lodge and the scientists of his day was how the ether could spin. As they understood it:

If the ether can be set spinning, therefore, we may have some hope of making it imitate the properties of matter, or even of constructing matter by its aid, But *how* are we to spin the ether? Matter alone seems to have no grip on it. As already described, I have spun steel disks, a yard in diameter, 4000 times a minute, have sent light round and round between them, and tested carefully for the slightest effect on the ether. Not the

¹²⁸⁹ *The Ether of Space*, p. 118.

¹²⁹⁰ *The Ether of Space*, pp. 118-119.

slightest effect was perceptible. We cannot spin ether mechanically.¹²⁹¹

We have already seen, however, that Lodge's experiments were sullied by his assumption that the Earth was moving at "nineteen miles per second" and thus his, and other experiments, would not be able to detect any significant effect on the ether. The point here is that Lodge and his colleagues recognized that the plenum of ether could perform as a rigid, solid mass if it were spun. Again, this mechanism is precisely what the Hildegardian system supplies to the universe of ether – a daily spin to keep it rigid and, as Hildegard puts it, "to keep it from melting" (that is, turning into a fluid).

In addition to the above, rotation is also involved in the relationship between electricity and magnetism, which will allow us to draw out further answers to the versatility of the geocentric universe. As Lodge explains the relationship:

Rotation is supposed to exist whenever we put a charge into the neighbourhood of a magnetic pole. Round the line joining the two, the ether is spinning like a top. I do not say it is spinning fast: that is a question of its density; it is, in fact, spinning with excessive slowness, but it is spinning with a definite moment of momentum. J. J. Thomson's theory makes its moment of momentum exactly equal to em , the product of charge and pole; the charge being measured electrostatically and the pole magnetically.

How can this be shown experimentally? Suppose we had a spinning top enclosed in a case, so that the spin was unrecognizable by ordinary means – it could be detected by its gyrostatic behaviour to force. If allowed to "precess" it will respond by moving perpendicularly to a deflecting force. So it is with the charge and the magnetic pole. Try to move the charge suddenly, and it immediately sets off at right angles. A moving charge is a current, and the pole and the current try to revolve round one another – a fact which may be regarded as exhibiting a true gyrostatic action due to the otherwise unrecognizable etherial spin. The Fact of such magnetic rotation was discovered by Faraday.¹²⁹²

This principle may explain why the Earth has a magnetic force pivoting off its poles and surrounding its entire circumference. Simply put, the rotation of the universe with its accompanying ether, which

¹²⁹¹ *The Ether of Space*, p. 120.

¹²⁹² *The Ether of Space*, pp. 121-122.

carries an electric field with its own impedance,¹²⁹³ will create a magnetic force on the poles of a stationary Earth.

¹²⁹³ According to "Space Must Be Quantized," *21st Century*, May-June, 1988, p. 26ff, the impedance of space is 376 ohms.

Hildegard and the Cause of Gravity

As we have noted earlier, Isaac Newton did not discover the nature of gravity. He merely gave us a mathematical formula to calculate its effects. Although Newton and his devotees usually describe gravity as an attractive force, the most that can be said for this view is that it satisfies the appearances. The main problem with viewing gravity as a local force due to some innate property of matter is that it would not begin to explain how gravity can operate over vast distances, otherwise known as the “action-at-a-distance” problem, something Newton hardly addressed, let alone solved.

Recall in our earlier discussion concerning the makeup of the atom that there exists a huge volume between the nucleon and the electron. In 1911 Ernest Rutherford, after bombarding very thin sheets of gold with alpha particles, discovered that even though the alpha particles were 8,000 times larger than the electron, and the metal foil was 400 atoms-thick, nevertheless, most of the particles penetrated the foil with little problem. Only a few, perhaps 1 in 1,000, were scattered, some deflected 90 degrees, others 180 degrees. An obvious interpretation of this phenomenon is that most of the alpha particles move through the atom as if it were almost completely empty. The few alpha particles that were deflected had done so because they hit the nucleus of the atom, which means that most of the mass of the atom is concentrated at the central point. As it turns out, only a quadrillionth of the atom is occupied by mass, that is, only 0.000,000,000,01%. What constitutes the other 99.999,999,999,99%? Hildegard’s vision tells us that it is the fourth element, “air,” or what we would understand as a subatomic ether that pervades the whole universe, yet it does not penetrate the nucleus or the electron but only the space between the two. In a simple analogy, we could say that the “fire” of the electron is bathed in a sea of cosmic “air” in order that it can continue to “burn.” As Hildegard describes it: “In each of the elements there indwells an air that corresponds to its nature.”¹²⁹⁴ Every cubic centimeter of space, and even matter itself, contains trillions upon trillions of these little entities, forming an invisible medium throughout the universe. As [Oliver Lodge](#) wrote, quoting [J. J. Thomson](#):

“In fact, all mass is mass of the ether; all momentum, momentum of the ether. This view, it should be said, requires the density of the ether to be immensely greater than that of any known substance.”

Yes, far denser – so dense that matter by comparison is like gossamer, or a filmy imperceptible mist, or a milky way. Not

¹²⁹⁴ “Einem jeden der höheren Elemente wohnt eine Luft inne, die seiner Beschaffenheit entspricht” (*Die göttlichen Werke*, 122, cited in *Das wahre Weltbild*, p. 103).

unreal or unimportant – a cobweb is not unreal, nor to certain creatures is it unimportant, but it cannot be said to be massive or dense; and matter, even platinum, is not dense when compared with the ether.¹²⁹⁵

This subatomic ether performs a number of important tasks, but probably the most important is that it helps create gravity. As it occupies the space in the atom, as in Rutherford's experiment, most of it passes through, but some of it hits the nucleus, yet it cannot penetrate the nucleus because of the latter's density. This fits the science we already know concerning protons. They are virtually indestructible and do not decay. Experiments with the proton reveal that its average lifetime must exceed 10^{32} years.¹²⁹⁶ Although the nucleus is about 10^{-14} cm in length, its density is far more compact. No one really knows how dense it is. In any case, the atom moves in whatever direction the ether moves the nucleus. There is no longer any need to wonder why atoms were designed with mostly "empty space." They were designed as such to allow them to be penetrated by even smaller unseen entities to create the phenomenon of gravity.¹²⁹⁷

As we noted above, modern science has found substantial evidence that open space is not a vacuum; rather, it is filled with infinitesimal particles. It was for this very reason that the interferometer experiments in the course of 50 years all demonstrated positive results for an ether circling the Earth, but results that were not even close to coinciding with an Earth revolving around the sun at 66,000 mph. We also noted earlier that Carl Anderson discovered the positron in 1932. From this discovery various scientists have understood that space is packed with electron-positron pairs (or what we have coined as "electropsons"), such that the sudden appearance of an electropson pair when a 1.02 MeV charge is administered in open space is that the charge

¹²⁹⁵ *The Ether of Space*, p. 116.

¹²⁹⁶ James S. Trefil, *The Moment of Creation: Big Bang Physics from Before the First Millisecond to the Present Universe*, New York: Scribner's Sons, 1983, pp. 141-142. Although protons have been theorized to consist of other particles (e.g., leptons, quarks), nevertheless, in the cosmic realm the proton remains indestructible. Whereas 100 MeV is needed to remove an electron from an atom, and 10^6 MeV to remove protons from neutrons, it would take 10^{11} MeV to break down a proton. By comparison, the best modern accelerators can presently produce 10^{12} MeV.

¹²⁹⁷ For an example of how this principle can be demonstrated, Posch cites that the Earth consists of only 10^{-14} % mass, based on the current atomic model in use today. This, of course, leaves 99¹⁴ % as empty space. If, in turn, the ether penetrates the Earth with a pressure of 10^{14} *p*, only 10^{-14} of this pressure is absorbed by the Earth's mass. The difference between the unhindered permeation and the resisted amount is as small as 10^{14} %. As such, 10^{-14} % of 10^{14} *p* = 1 *p*. This equation corresponds exactly to the Earth's measured gravity, which is 1 *p* or 1 gram per square centimeter (*Das wahre Weltbild*, p. 104).

is jarring the particles loose from the all-pervading electropon lattice. One scientist, Menahem Simhony, estimates that the number of electropon pairs in one cubic millimeter of space is 6×10^{30} , with a binding energy of 27 quadrillion kilowatt hours, yet this energy is a million times smaller than the binding energy of the atomic nucleus.¹²⁹⁸ Hence, the nucleus would remain impenetrable to the electropons, and thus the electropon sea could move the nucleus. Thus we have a viable mechanism for gravity. Later we will discover what might move the electropon sea against the nucleus.

Simhony's value of 10^{30} electropons per cubic millimeter of space is precisely the same value found by another researcher in the field, Allen Rothwarf (although the two scientists worked independently).¹²⁹⁹ Moreover, setting their sights on specifically addressing the gravity question, Frederick Rothwarf and Sisir Roy combine the electropon pairs into a second ether composed of particles on the Planck scale, so that there are "two ethers." Offering a solution to gravity, they write:

These particles, called partons or gravitons, are assumed to have a mass equal to the Planck mass¹³⁰⁰ and to constitute an ether A_G , that transmits gravitational forces at a speed c_G , which exceeds the speed of light c_0 . Along similar lines, Van Flandern and Vigier have analyzed planetary and cosmological data to obtain a lower limit of c_G , $2 \times 10^{10} c_0 = 6 \times 10^{18}$ m/s" [i.e., 20 billion times the speed of light].¹³⁰¹

Einstein, of course, had limited the speed of gravity to luminal parameters, but many physicists admit that this limitation simply will not survive in a universe of Planck dimensions, and it is one of the reasons why Relativity and Quantum Mechanics have never had a successful union.

That gravity is based on an ether-pressure is related to the various corpuscular theories of gravity originating in the work of [Nicholas Fatio de Duillier](#) (b. 1664) and Georges-Louis Le Sage (b. 1724), and

¹²⁹⁸ Menahem Simhony, *Invitation to the Natural Physics of Matter, Space and Radiation*, Singapore, New Jersey, London, Hong Kong, World Scientific Publishing Co., 1994.

¹²⁹⁹ Allen Rothwarf, "Cosmological Implications of the Electron-Positron Ether," *Physics Essays*, 11, 1998. John Kierein finds a similar density to the electron-positron model, and by it shows that redshift is due to the Compton effect (John Kierein, "Implications of the Compton Effect Interpretation of the Redshift," *IEEE Trans. Plasma Science* 18, 61 (1990).

¹³⁰⁰ $m_p = (hG/c)^{1/2}$

¹³⁰¹ "The Time Dependence of Fundamental Constants and Planck Scale Physics," in the paper dated November 14, 2003, p. 8.

continuing in modern times to the more advanced theories. For example, astrophysicist Toivo Jaakkola writes:

A few words about the gravitational ether, and the ether concept in general may be in place here. The ether hypothesis was thought to be buried by the Michelson-Morley experiment, but today it is more alive than ever, in the form of the CBR [Cosmic Background Radiation]: experiments capable of finding the ether were not possible in the 1880s, but were possible in the 1960s. In a sense, the electromagnetic ether has always been observed – as the heat of the Sun (since as pointed out, CBR is reprocessed photons).

The gravitational ether must be structured much like its electromagnetic counterpart. Local fields would cause the ordinary gravitational processes. Corresponding to CBR, there must be a cosmic background gravitation, CBG, probably with its specific gravitational spectrum. How to observe CBG? It has been already observed, as the cosmological redshift effect, z .

Gravitation works *via* gravitational quanta, gravitons....Quantized gravitation is also required by the redshift and other equilibrium effects. Gravitons are gravitational equivalent to electromagnetic quanta, photons, both those of the cosmic background radiation CBR and incident photons from galaxies. Gravitons and baryonic matter interact and are in equilibrium on the cosmological scale. The graviton-baryonic interaction is the redshift effect, and the CBR is re-emission of energy gained by the cosmological gravitons in the redshift effect.

Gravitation on a body is a pressure effect of gravitons flowing from the background space. As a rule, due to the equilibrium principle, the flow is proportional to the mass of the body. As for all concentric flows (e.g., radiation) the surface density of the graviton inflow follows the familiar inverse square distance law....The energy of the gravitons is proportional to the parameter which we call “strength of gravitation,” G . Therefore, we obtain for the surface gravity on a spherical body with mass M and radius R the familiar Newtonian $a = GM/R^2$.

All the main cosmological, astrophysical and physical facts: the gravity and Olbers paradoxes, redshift effects and CBR, gravitation and radiation, and the existence of particles can be conceived in the framework of this ether concept.¹³⁰²

¹³⁰² “Action-at-a-Distance and Local Action in Gravitation,” in *Pushing Gravity*, pp. 157-159.

In summary, Jaskkola says:

- 1) The CMB [CBR] radiation shows that ether exists all over the universe.
- 2) The redshift shows that a Cosmic Background Gravitation in the form of gravitons also exists.
- 3) Gravitons interact with baryonic matter (the atomic nucleus).
- 4) Gravitation on a body is a pressure effect of gravitons flowing from the background space.
- 5) The strength of the gravitons is equal to the gravitational constant G , and the force is measured by the inverse square law.

Halton Arp adds that gravitons are:

...very low mass particles with a huge de Broglie wavelength compared to photons [and thus] have much less interaction with the intergalactic medium....The photon is transmitted through the average cosmic false vacuum, material vacuum or zero point energy field – to use just a few names given to the old fashion concept of ‘ether.’ But the graviton interacts with much less of this molasses and hence moves much faster.¹³⁰³

Reginald T. Cahill adds that interferometer experiments dating back to Miller in 1925 and the coaxial cable experiments up through DeWitte in 1991 show the presence of gravitational waves. These waves are said to be the proper interpretation of the periodic and non-random fluctuations in the same forces measured by the “Stanford University-NASA Gravity Probe B” satellite experiment that measured a geodetic precession and the Lense-Thirring ‘frame-dragging.’ Cahill concludes that the data shows “gravity may be...well represented in terms of a ‘flow’ system involving a velocity vector field...and this formalism is physically indistinguishable from the Newtonian formalism...”¹³⁰⁴

The Physical Cause of Gravity

How might this ether “flow” system work, mechanically speaking, to cause the effect of gravity? As we noted previously in Chapter 8 and will repeat here, the mechanism may actually be very simple. The ether has a granularity and concentration that is far finer and far denser, respectively, than ordinary matter. As such, ether will serve

¹³⁰³ “The Observational Impetus for Le Sage Gravity,” in *Pushing Gravity*, p. 4.

¹³⁰⁴ Reginald T. Cahill, “Novel Gravity Probe B Gravitational Wave Detection,” Flinders University, Adelaide, Australia, August 21, 2004, p. 3. Various universities around the world have established Gravitational Wave Physics. The lab headed by Lee Samuel Finn and Benjamin Owen at Penn State University is one example.

as the interstitial substance that fills the so-called “empty” space within the atom, as well as the space outside the atom. Since, however, the ether does not penetrate the atom’s individual particles (protons, neutrons, etc), these atomic particles thus account for a percentage of the mass of the atom. But since the atomic particles are less dense than the ether, yet they occupy space in the atom, this means that the total density within the atom will be slightly less than the density of ether outside the atom. This imbalance will cause what can best be described as a partial vacuum in the ether, and the ether will seek to correct the vacuum by attempting to come to equilibrium. Here is the key: *The effort to correct the vacuum is the cause of gravity.* The less-dense ether within the atom will seek to draw inward the denser ether that is outside the atom, and this force will continue until a balance is reached, but, in fact, a balance is never reached, and thus the force of gravity persists indefinitely.

In Newton’s case, for example, the apple falls to the Earth because the larger the mass, the stronger the vacuum. The Earth, which is the larger mass, will create a stronger ether vacuum than a smaller mass, and thus the smaller mass (the apple) will be drawn toward the larger mass by the force of the Earth’s greater ether vacuum. The reason the Earth creates a greater ether vacuum than the apple is that the more atomic mass an object has, the less interstitial ether it will possess in its given volume, and thus the greater the imbalance it will have with the ether outside its mass. The Earth, having more mass than the apple, has less interstitial ether within its particular volume and thus a greater ether vacuum.

By the same principle, Jupiter will have more gravitational force than the Earth because Jupiter, having more atomic mass than Earth, will have less interstitial ether for its given volume, and thus create a greater ether vacuum, which then attempts to pull more forcefully the ether from outside the planet in order to reach equilibrium.

The Twelve Cosmic Winds

Interestingly enough, the foregoing descriptions of gravity are very similar to what Hildegard saw in her heavenly visions. She reveals a universe filled with cosmic winds originating at the background of deep space. Altogether there are twelve cosmic winds and their points of origin are symmetrically and evenly divided around the perimeter of the universe. Essentially, the winds are arranged in such a way that they create a continual flow of pressure towards the center. We can imagine these as concentric spheres of cosmic ether waves moving toward the center at a constant speed, a sort of pressure wave.

The movement of the winds is somewhat complex. One set of winds begins outside the outer fire layer of the south side of the universe and blows laterally around the circumference and, after bouncing off the edge of the universe, curls inward toward the center of the universe where the Earth is located. Another set of winds begins at the north side of the universe in the inner fire layer and performs the same action as the south side winds. Another set of winds begins at the east side of the universe in the ether layer and performs the same action as the north and south winds. Finally, a fourth set of winds begins at the west side of the universe in the water layer and follows the same pattern as the other three winds. Hildegard employed the names of animals both to distinguish each originating point (i.e., south, north, east, or west) and to distinguish the separate winds within each origin point. Altogether, in Hildegard's vision, there are four main winds (which originate from the four compass points) and eight adjacent winds.¹³⁰⁵ These twelve winds, symmetrically situated in space as if they were each at the hour position of a giant clock, produce cosmic waves distributed to the whole universe and which are directed, like spokes of a wheel, toward the center, where Earth is located. The pressure created by the twelve winds is distributed evenly at all points and consequently, as they reach the center, they are in mechanical equilibrium and thus hold the Earth in the exact center. These same winds, as they travel from the outer edge of the universe toward the Earth, create the phenomenon of gravity and inertia for every other celestial body in the universe. Consequently, any celestial body outside the Earth's immediate area will experience disproportional cosmic wind currents and thus move with respect to those currents.

Hildegard intimates that the winds originate both by the energy latent within each celestial layer (based on the principle that "fire" is included in each of the other three elements: air, water, and earth), yet the largest and primary cosmic wind begins in the layer of pure energy that is in the outer layer of the universe where also the universe's most massive stars are located.¹³⁰⁶ In a fashion easily explainable in terms of

¹³⁰⁵ *Welt und Mensch*, 36; *Das wahre Weltbild*, p. 100.

modern science, the energy from the outer layer of the universe creates the inward gravitational pressure as it moves the particulate substance in space in symmetric wave motion towards the center of the universe. In this way, every object of the universe will experience gravity and inertia. Hildegard insists that there is neither movement nor force without these cosmic winds. Thus gravity is not a “curvature of space” and inertia is not an inherent property of motion, but both are the result of a well-designed universal machine working on the principle of mechanical cause and effect. Hildegard’s vision of universal winds thus replaces the need for Dark Matter, for we can easily see that gravity is not dependent on the presence of matter; rather, it is a pressure force caused by the transfer of some type of electrical or plasma energy into a kinetic energy so that the cosmic winds can carry the waves of gravity and interact with the matter in a closed universe. It is possible that the high energy gamma-ray bursts or X-ray bursts found over the entire perimeter of the cosmos may be the peep holes by which we can verify the existence of this universal energy.

¹³⁰⁶ In one instance, Hildegard attributes the origin to God himself, as she quotes what the man in the center of the universe said to her: “I am hidden in them as a fiery power. They blaze upwards out of me!” (*Die göttlichen Werke*, 42, *Das wahre Weltbild*, p. 101). This revelation thus makes an intimate connection between God and the universe, as suggested by Colossians 1:16-17: “for in him all things were created, in heaven and on Earth, visible and invisible, whether thrones or dominions or principalities or authorities – all things were created through him and for him. He is before all things, and in him all things hold together.”

The Sixteen Controlling Stars

In conjunction with the cosmic winds, Hildegard's vision reveals sixteen of the most massive and powerful stars placed symmetrically at the perimeter of the outer fire layer of the universe. Four stars are positioned between a pair of compass points. Since they are evenly spaced from one another around the universe's circumference, their center of mass is the Earth itself and their energy is directed towards it like the spokes of a wheel. As Hildegard puts it: "If there were more stars they would overload the celestial vault. Fewer would weaken and damage the vault...They are equally effective and adhere to the firmament like nails in a wall. They never leave their place but rotate with the primordial vault, which they help sustain."¹³⁰⁷ The two outer stars from each compass quadrant radiate their tremendous energy towards the center (Earth), while the two inner stars in the quadrant (eight in all) radiate as far as the inner fire layer. All in all, Hildegard says:

...these stars strut the entire primordial vault and offer resistance to the adjacent winds so that the winds do not move the firmament too much. They provide the cosmic air with the proper balance and are compatible with each other, because one helps the other carry the celestial vault.¹³⁰⁸

The purpose for the two inner stars radiating only to the inner fire layer is "that they support the adjacent winds and offer resistance to the fire so that it need not send out excessive blazes."

As for the billions of other stars in the cosmos, Hildegard states that they are evenly spaced throughout that "ether" layer and the "illuminated air" layer, and "warm up the firmament and strengthen it" (*viz.*, the 2.73° Kelvin temperature). This would mean, then, that there are stars above and beneath the "water" layer, or what we commonly call "the waters above the firmament."

Modern science has confirmed the existence of massive stars in the universe. Already in the time of Albert Michelson in the 1920s, their existence was known and measured. Using the 100-inch Mount Wilson telescope, Michelson and Francis Pease were able to calibrate stars with linear diameters of 20 million miles (Arcturus); 30 million miles (Aldebaran); and 400 million miles (Antares). These figures haven't changed much from recent calibrations.¹³⁰⁹ They also found that

¹³⁰⁷ *Die göttlichen Werke*, 111, *Das wahre Weltbild*, p. 102.

¹³⁰⁸ *Die göttlichen Werke*, 111, *Das wahre Weltbild*, p. 102.

¹³⁰⁹ Arcturus: 30 million; Aldebaran: 35 million; Antares: 410 million. Bernard Jaffe, *Michelson and the Speed of Light*, p. 159.

Betelgeuse, a variable, pulsating star, measures between 360 and 500 million miles in diameter. To get a grasp of how big these stars are, at its widest diameter, Betelgeuse would be twice as big as all of the spherical volume between the sun and the orbit of Mars. It is these types of stars, sixteen of them, that Hildegard says rule the universe's distribution of energy.

The Effects of the Cosmos upon Earth

In Hildegard's cosmology all the heavenly bodies communicate with one another through the four elements of fire, air, water, or earth. Nothing is wasted or idle. For instance, Hildegard's visions show that the stars have a direct effect on the clouds in the Earth's atmosphere. She writes:

With their rays they penetrate the clear air all the way to the clouds under the strong, white, luminous air and hold them so that they stay within their God-given boundaries.¹³¹⁰

She continues:

And this same air – the illuminated air over the atmospheric layer – also seems to carry the clouds a little higher, which are soon flying high and full of light, soon descending and dark. This spews out the watery air and gathers it back together, just as a smith's bellows brings forth a blow and draws it back in. Therefore certain stars, while put into the element of fire, then ascend in their circulation, drag the cloud upwards, whereby they too become illuminated. But when they descend in their circulation, they release the clouds again and thus they are dark and trigger downpours.¹³¹¹

This revelation explains a heretofore mysterious phenomenon (i.e., how water, which is much heavier than air, can stay above air), but it is a solution that neither modern meteorology nor astrophysics has ever considered. According to Posch, what Hildegard is describing is a process whereby the electromagnetic impulses of the stars (which can act on the Earth's entire atmosphere instantaneously since they form a giant sphere of constant and inexhaustible power) act like an anode and cathode. The starlight ionizes the air, which, in turn, creates differentiated layers of gas. The gas layers, reacting to the flow of gravity, create changes in air pressure while also seeking to stabilize the total energy of the system. Hence, the cosmic pressure from gravity coupled with the reverse pressure created by the ionization of the atmosphere describes Hildegard's "bellowing" effect, which we experience as high- and low-pressure pockets throughout the Earth. The whole process results in a continual regeneration of the atmosphere. One of the effects of such atmospheric purification is the production of soft rainwater through a type of distillation process, a distillation that is initiated by the immense energy of starlight from billions of stars.

¹³¹⁰ *Die göttlichen Werke*, 111, *Das wahre Weltbild*, pp. 102, 105.

¹³¹¹ *Die göttlichen Werke*, 66, *Das wahre Weltbild*, p. 105.

Moreover, a similar process of gas exchange occurs throughout the universe and is one of the reasons that the temperature can remain at precisely 2.73° Kelvin. Such a process would require the existence of massive amounts of water in space similar to the way water exists in the Earth's atmosphere. Indeed, our earlier citations of the scientific evidence show that such amounts of water exist not only in space but also in the stars themselves.

Regarding electrical processes playing some part in the attraction and repulsion of cosmic entities, as early as 1830, Ottavio F. Mossotti, a French physics teacher at the University of Buenos Aires, postulated that attractive force was caused due to the very slight excess of attractive forces between electrical particles as opposed to the particles' force of repulsion. Since matter is understood to contain positive and negative electricity, obviously, if the attractive forces between particles of opposite electrical charge exceed the repulsive forces of the like particles, an attraction would result.¹³¹² Since electrical forces are so much stronger than what we experience as gravitational force, it would only require a slight residue of attractive electrical force to produce the forces we experience in the cosmos. This would require that Coulomb's law, which holds that two repulsions and two attractions cancel each other, could be slightly weighted to one side or the other. Of note, Ampère had shown that another motion is produced between electrical charges that are not described by Coulomb's law. Wilhelm Weber added that attraction also depends on the velocities and accelerations of the bodies in view, whereas Coulomb's law applies to bodies at rest.¹³¹³ In any case, Weber seriously considered Mossotti's hypothesis, publishing a paper on the relationship between electricity and gravitation which relates the difficulty in testing whether there is, indeed, a slight difference between attractive and repulsive forces.¹³¹⁴

Following Weber, Walter Ritz also questioned the electrodynamics of Maxwell and Lorentz, and attempted to revive the abandoned approach of Gauss and Weber. He postulated that the result of the electrical forces between two bodies would be attractive. His reasoning was not based on Mossotti's theory, however. Ritz based his on the internal motions of the electrical particles in the atoms. Having

¹³¹² O. F. Mossotti, "On the Forces which Regulate the Internal Constitution of Bodies," 1830.

¹³¹³ Wilhelm Weber, "Elektrodynamische Maasbestimmungen: Über ein allgemeines Grundgesetz der elektrischen Wirkung," Werke, Berlin: Julius Springer, 1893, pp. 25-215. Cited in *21st Century Science* by Laurence Hecht, Spring 2001.

¹³¹⁴ Wilhelm Weber, "Elektrodynamische Maasbestimmungen, insbesondere über den Zusammenhang des elektrischen Grundgesetzes mit dem Gravitationsgesetz," Werke, Berlin: Julius Spinger, 1894, pp. 479-525. Cited in *21st Century Science* by Laurence Hecht, Spring 2001.

died prematurely, Ritz had no opportunity to develop his idea. Current Plasma cosmology is just now delving into these areas of research and much has been written on what has come to be known as the “electric universe.”¹³¹⁵

¹³¹⁵ As plasma physicist Eric Lerner suggests in his book *The Big Bang Never Happened*, Vintage Books, 1992; also Erwin Saxl, “An Electrically Charged Torque Pendulum,” *Nature*, v. 203, pp. 136-138 (1964); C. F. Brush discovered anomalies between mass and gravity in certain materials, and concluded: “the ratio of mass to weight is not the same for all kinds of matter, as has been supposed, and the mass-weight ratio is not constant even in the same kind of matter” (*Physical Review*, vol 31, p 1113(A); Vol 32, p 633 abstract. Proc. Amer. Philosophical Soc. Vol IX No. 2, 1921; Vol LXVII No. 2, 1928; Vol LXVIII No. 1, 1929. *Journal of the Franklin Institute*, Vol. 206, No. 1, 1928). The *Biefeld-Brown Effect*, as found by Thomas Townsend Brown in the late 1920’s, produced a slight weight change in a specially constructed capacitor when it was subjected to an extremely high DC voltage. Others have verified the effect and several patents have been granted over the years, but no one has been able to explain what the effect is or its source. Roger Brown, in *The Biefeld-Brown Effect Revisited* (1996), offers an explanation to the origin of the force. Many others have written on this topic, but theories postulating that electrical forces cause gravity contradict the tenets of General Relativity, and therefore such papers are usually shunned by the major physics periodicals.

Energy Supplied to the Sun

Interestingly enough, plasma cosmology holds that the energy from the sun and stars that creates heat and light does not originate from a process of nuclear fusion within the cores; rather, it originates from the energy given to the star from external electrical forces in the cosmos which are then distributed on the surface of the star. Hildegard's visions portray something very similar, at least for our sun. Her visions reveal that in order for the sun to remain aglow, it must always be supplied with the cosmic air current. As we have already noted, the air current originates in the outer layers of the universe, yet Hildegard adds that the planets themselves help radiate the air current toward the sun. Mars, Jupiter and Saturn work as a three-blade fan circulating the rarified cosmic air. As Hildegard says:

And there are only three, for if they were more, they would ignite the fire too much and disturb it through their orbits. Of if they were fewer, the fire would become cold in its blaze."¹³¹⁶

The planets enable the sun. Without them, the sun could not exist. They add warmth to it....The planets move from west to east counter to the firmament. Thereby they restrain the fire of the sun with their fire and, on the other hand, renew it for the great kindling. If they did not run counter to the firmament and hurry towards the sun from behind, the sun would not be renewed but freeze into solidity....That's why the planets have effectively been put in the firmament by the Creator of the world in this manner.¹³¹⁷

Mathematical Constants in the Geosystem

As we have noted, although we commonly accept that the sun rises in the east and sets in the west, in actuality the firmament is rotating east to west (or clockwise for someone standing at the North Pole) and it is carrying the sun. At the same time, the sun is making a very slow counter-clockwise movement, from west to east, against the firmament. Analogously, we might say the sun is moving slowly upstream like a salmon. As it moves against the current, the sun takes 27.2753 days to

¹³¹⁶ *Die göttlichen Werke*, 92. *Das wahre Weltbild*, p. 133.

¹³¹⁷ *Die göttlichen Werke*, 101. *Das wahre Weltbild*, p. 134. Posch notes: "Accordingly, it is manifestly known that the periodic activity of the sun is linked to the orbits of the planets. The fluctuating number of sun spots was discovered by Samuel Schwabe the previous century. They can become so big that sometimes at sunrise one can see them with the naked eye. Emerging in a period of about 11 years, the sun spots indicate a cooling of the sun's surface" (*ibid*).

make a complete counter-revolution within the firmament, based on sidereal time and position.

While the sun is orbiting the Earth, so is the moon, and in almost the same way and in the same time. As the firmament moves clockwise (from east to west) it carries the moon, and thus the moon appears to rise in the east and set in the west, just like the sun. Its time between rising and setting is almost identical to the sun's, except that it needs an extra 0.0447 days to make its revolution around the Earth, based again, on sidereal time and position. In all, the moon takes 27.32 days to complete one revolution around the Earth. (Keep in mind, however, that compared to the background of the stars, both the sun and the moon are slowly moving west to east on a daily basis).

That the sun and the moon have an almost identical time of revolution around the Earth is no mere coincidence. Since each revolves in about 27 days, there is a one-to-one ratio. This ratio is needed to establish the balance in the universe's movements. Any faster or slower and the movement would be out of kilter, namely, the balance between what Newtonian physics understands as the centrifugal and centripetal forces, but also other important forces, such as the gravitational constant, the angular momentum of subatomic particles, and most if not all of the other fundamental constants we have noted previously.

According to Posch, the precise number 27.32 becomes very important in cosmological mechanics. Basing the rotation of the firmament on a 366-day-per-year cycle, there are certain fixed ratios that naturally develop. That is, 1 year divided by 366 days equals 0.002732 years; and 1 year divided by 27.32 days equals .03660 years. For the first value, we can say that 1 day equals 0.002732 years, or that the firmament rotates 360° every 0.002732 years. Other uses appear in, for example, the acceleration of the moon as it orbits the Earth at 0.273 cm/sec^2 , and the moon's radius being 0.272 of Earth's radius, which shows that there exists an intimate mechanical connection between the Earth and the moon. Perhaps Hildegard's statement that it is the moon's orbit around the Earth that is the basis "by which everything else is reckoned" can now be better understood.¹³¹⁸

¹³¹⁸ *Das wahre Weltbild*, p. 123.

No Ellipses for the Solar Movements

Another interesting facet of Hildegard's universe is that the path the sun traces out as it orbits the Earth is not an ellipse. In keeping with the Aristotelian model, the sun moves in a circle. As Hildegard describes it:

The other planet moves counter to it and drags the sun upwards to the constellation of Aries....These propel the sun forward with great force [acceleration]....The two planets accompany the sun for a while so that it won't move downwards too fast. [At Virgo] the sun moves more slowly on its path [deceleration].¹³¹⁹

Actually, in the relationship of the sun to the Earth, a non-elliptical path is not critically significant. Although in heliocentric illustrations the ellipsis of the Earth's path around the sun is often exaggerated for effect, in actuality it is very close to a perfect circle, with only a 3% variance. Still, there is slight difference, and this difference would accumulate over time and thus a precise understanding of these movements is necessary to know.

We noted earlier in comparing Kepler's solar system against Copernicus' that, whereas Copernicus sought to keep the perfect circles of Aristotle and Ptolemy, this system did not work properly, forcing Copernicus to include 48 epicycles to his planetary movements. Seeing these flaws, Kepler found that the data of planetary movement (which he obtained from Tycho Brahe) fit much better when the orbits of the planets around the sun were elliptical, some of the planets having a sharper ellipse than others. In that comparison, we also noted that an elliptical path is equivalent to a circular path if the speeds of the orbits are adjusted. Hence, as long as Hildegard's geocentric model can account for these differences, her system is equivalent to the Keplerian elliptical system. This is not to say that the Keplerian system is the standard by which all other systems are judged (for we have seen that even the Keplerian solar system has its difficulties), but only to say that Hildegard's model explains the motions of the sun and planets in circular orbits just as well as the best heliocentric model explains elliptical orbits.

We start this analysis by making reference to the phenomenon of the [Analemma](#). By photographing the sun at the same time each day for an entire year and assembling the photos so that they show the progressive movement of the sun, a figure-eight pattern is revealed. In addition, the lower loop of the figure-eight is longer and covers more area than the upper loop. The first composite photograph of this phenomenon was produced by Dennis Di Cicco and published in *Sky and*

¹³¹⁹ *Das wahre Weltbild*, p. 143.

Telescope in 1979. In the heliocentric system the Analemma's asymmetry is explained by the Earth's tilt of 23.45° in addition to the ellipses it forms as it travels around the sun. In the Hildegardian geocentric system it is explained by the precessional movement of the sun in addition to its acceleration and deceleration at specific points in its orbit. As Posch discovered, these two independent movements of the sun follow the principle of the Cardanic function. As one text stated:

A mechanism that is particularly useful, surprisingly, is the cardanic joint, which is well-known in other applications. Its precision is based on a caprice of nature. Moreover, it is certainly an interesting coincidence that certain basic relations of celestial mechanics describe the same functional relations as the movement of the universal joint or cardan joint. The effect of the cardan is understood in the following relation: $\text{Tangent B} = \text{Cosine N} \times \text{Tangent A}$, where A = angle at the drive; B = angle at the output; and N = slope between A and B. The exact same function describes the relation between the eccentric and the true anomaly...Further, the relation between the center of the ellipse and the eccentric anomaly is, in turn, the Cardanic function.¹³²⁰

The "caprice of nature" to which the author refers is that, although the drive of a universal joint is uniform, the output is asymmetrical. This causes the mechanism to wobble or create a precession. This is why all rotating shafts that use a universal joint will vibrate, and it is the same reason why a gyroscope will wobble around its center of mass when it is hit by an external force. In essence, an elliptical orbit in which the sun or a planet accelerates or decelerates in keeping with Kepler's law of areas is equivalent to the same principle that governs Cardanic movement. The question is: which system is correct? If the sun and planets travel in circular orbits although at asymmetric velocities, and by doing so match Kepler's elliptical orbits, then there is nothing in the mathematics that can deny it as a viable order of celestial movement. In fact, Kepler knew that the sun moved faster through the stars at various times of the year. As Einstein notes of Kepler:

To begin with it followed from observations of the sun that the apparent path of the sun against the background of the fixed stars differed in speed at different times of the year...¹³²¹

¹³²⁰ Quoted from *Der Himmel auf Erden*, Meier, cited in *Das wahre Weltbild*, p. 145. In orbital motion, an elliptical orbit is understood as the product of three elements: (1) the semi-major axis, which gives the size of the orbit; (2) the eccentricity, which gives the shape of the orbit (between 0 for a circle and 1 for an infinite parabola); and (3) the mean anomaly, which is an angle growing at a steady rate up to 360° for each orbit. The actual position, however, is given by the *true anomaly*, which is given in polar coordinates.

This is quite significant, since if Kepler understands the stars as fixed in space, then the sun's acceleration and deceleration against such a fixed background means that the sun is producing an absolute movement. In any case, whereas Kepler's model is quite complicated, Hildegard's model can be represented by a simple [sine curve](#) in which the acceleration and deceleration of the sun represents the positive and negative curves on the x -axis of the graph.

Yet there is another ingredient to this phenomenon. As we noted above, the [Analemma](#) shows that the sun travels farther in the lower loop of the figure-eight than it does at the top loop. There are two reasons why this is so. The first is that the sun is traveling on the ecliptic plane that is oscillating side-to-side over a span of 46 degrees in the course of one year. But it is not only oscillating with a side-to-side motion but with a circular motion, just like the plane of a spinning gyroscope that starts out with a 23.5° tilt (provided we keep the gyroscope spinning). To get a good mental picture of how this occurs, one can [view the planet Saturn over the course of its orbit](#) around the sun. Saturn's rings will represent the plane of the ecliptic while Saturn itself represents the Earth. Over the course of its 29.5-year orbit, Saturn's equatorial plane will oscillate side-to-side 54 degrees, or 27 degrees above and beneath its center of mass. As it does so the plane will also precess, which will appear in telescope photographs showing the rings moving front-to-back as well as side-to-side, just as in gyroscopic motion. If one were to attach a long pencil to the rings and have it draw on a background behind Saturn, one would see the characteristic Analemma.

These Analemmas, however, are made without the ellipses of the Keplerian system. The reason is that the sun will orbit the Earth in an asynchronous manner, accelerating and decelerating at periodic points in the orbit. In all, there are two accelerations and two decelerations, evenly divided over the orbit. Using the face of a clock to create the image, from 12-3 the sun is accelerating; from 3-6 it is decelerating; from 6-9 it is accelerating; and from 9-12 it is decelerating, following the typical sine curve. As the sun makes these varying movements in gyroscopic fashion, the Cardanic function will produce the characteristic elongated lower loop of the Analemma.

In addition to the sun's annual precession, there is another precession that it creates, although this one is over the course of 26,000 years. As we noted earlier, the sun is revolving daily with the rest of the universe in a clockwise direction around the Earth each day. But the sun is also moving in a counter-clockwise motion against the clockwise motion of the universe. Because of the sun's asymmetrical gyration in its

¹³²¹ On the occasion of the three hundredth anniversary of Kepler's death. Published in the *Frankfurter Zeitung*, Germany, November 9, 1930, Albert Einstein, *Ideas and Opinions*, New York, Crown Publishers, 1954, Wing Books, 1984, p. 263.

orbit, this will cause it to advance 50 arc seconds beyond the starting point of the annual revolution, and this will cause the sun's orbit to precess ever so slightly against the uniformly rotating universe. Over the course of 26,000 years, the sun will come back to the beginning of its precession cycle. Whereas the heliocentric system attributes the 26,000-year cycle to the precessional movement of the Earth's axis, which is said to be generated by the bulge in the Earth's equatorial plane (even though satellite photographs of the Earth do not show an equatorial bulge), geocentric cosmology attributes this precession to a miniscule time difference in the movement of the sun against the firmament. Consequently, this 26,000-year precession will cause the [Analemma to shift](#) to the east each year by 50 arc seconds against the background of the stars.

The next issue to be investigated concerns the force that is causing the sun and the planets to accelerate and decelerate at precise periodic points in their orbits. Before we answer this question, we should note that the same question should be asked of those who advocate the Keplerian model of ellipses, that is, according to Kepler's second law, what, precisely, causes the planets to trace out equal areas in the same time period? A Keplerian would answer this challenge by appealing to the "force of gravity" and the "force of momentum," showing us by mathematical equations how these two principles work in tandem. But in reality these mathematical equations neither tell us what moves the planet in its designated orbit, nor the cause of gravity or momentum. The equations merely measure the respective forces. Moreover, in not knowing the cause of the forces, the Keplerian cannot even be sure that the orbits of the planets are ellipses. The ellipse is merely his most convenient mathematical model, but it is certainly not the only possible model. Hildegard's system is very unique because she tells us the physical cause of every movement in the system, and it is then our job to apply the mathematics to what we know is the reality, rather than, as Kepler did, create a mathematics for something he did not know was the reality.

We noted previously that in Hildegard's system the planets are propelled around the sun through a system of cosmic eddy currents, which have varying strengths depending on the planet in view. Now we will add a second dimension to the movement of these currents. The currents will periodically accelerate or decelerate because, as Posch says, "the center of gravity of the cyclonic counter-rotation lies in the solar mass, whereas its point of rotation is the Earth."¹³²² He further explains that the rotation of the universe is centered on the north-south axis of the Earth, but that the counter-rotation of the sun intersects the north-south

¹³²² *Das wahre Weltbild*, p. 149. His German reads: "Der Grund liegt darin, weil der Schwerpunkt der zyklonförmigen Gegendrehung in der Sonnenmasse liegt, während ihr Drehpunkt die Erde ist."

axis at an angle of 23.5 degrees. This creates a “rectified current” between the sun and the Earth, which results in an acceleration of the sun, and likewise for the inner planets as opposed to the outer planets. Since there are two opposing currents: (a) the current causing the universe to rotate around the Earth, and (b) the current causing the sun to move against the rotation of the universe; and since these currents pivot off a fixed Earth, there will arise differences in current pressure that will cause periodic acceleration of anything outside the Earth. Calculating the rate of acceleration is rather simple. Using the sine curve we can determine the measure by which any planet will deviate from uniform speed.¹³²³

Another factor in these movements is the tilt of the sun. According to Posch’s calculations, the sun is at a constant [axial tilt of 2.83°](#) eastern longitude vis-à-vis the vertical of the ecliptic plane. (In the Copernican theory the sun is tilted at 7.25° but this value does not make any appreciable difference in the movement of the planets). On January 5, as it would be viewed from Earth, the sun’s axis is perpendicular to its equator and it has the lowest speed in its orbit. Normally we would think that these changes would begin to occur at the winter solstice on December 21-22, but because of the sun’s axial tilt, it is the case that the gyroscopic effect, which in turn produces its angular momentum, gives the sun about an extra two weeks before it reaches its lowest ebb. Once it reaches the lowest speed on January 5, it will immediately begin to accelerate. This acceleration will last until about March 6, and then it will begin to decelerate until about July 7. At this point the sun’s axis is once again perpendicular to its equator (as it was on January 5), but this time the axis is tilted 2.83° toward Earth instead of away from it. On July 7 the sun will again accelerate until September 8 and then decelerate until January 5. Incidentally, these fluctuations in speed of the sun in Hildegard’s system would equate to the eccentricity of the Earth’s orbit in the Copernican system. Quoting Posch’s calculations in detail, we read:

The acceleration of the sun starts, in each case, after the winter solstice around January 5th and after the summer solstice around July 7 and lasts a quarter of a year each time. The angular momentum, accordingly, amounts to 2/4. Canceled down, this corresponds to the well-known value 1/2, i.e., 0.5. If we calculate using an angular momentum of 1/2, we get a yearly

¹³²³ Posch adds that in changing from an elliptical to a sinusoidal acceleration, one must include the necessary conversion factors. Putting the data in dBASE4, he gives the parameters as: $k = 360/365.2422$ = constant angular speed of the sun; $n = 1$ = trip meter (in loop per day + 1); exz = eccentricity (starting with a zero value on January 5th); $x1 = DtoR(n \times k)$ = average daily increase in radian measure where D to R is degrees to radian; \times = multiplication. The resulting equation is: $y = DtoR(exz) \times \sin(x1) \times 180/\pi$.

period. But if we are more correct and make it 2/4, as it corresponds to reality, then we get the desired semi-annual period. To make it easier, we simply cut the circle (360°) and the circular number (π) in half, whereby we receive the appropriate value of the periodic acceleration (in the Copernican system = eccentricity); $Exz = \text{eccentricity} \cdot 180 / (\pi / 2)$.¹³²⁴

Because the new method yields the acceleration factor (x1) from the daily increase (days \times 0.98°), there follows from it the conversion of the elliptical eccentricity (exz) from the residual of the central equation (c) in a daily fraction. To obtain exact values for our starting position (earth/sun), we need to consider the residual speed of the ‘run-down phase’ as residual acceleration.

Only in this manner are the digits after the decimal point of the beginning value sufficiently exact. Thus, the formula for our docking maneuver must be:

$$\begin{aligned} \text{Daily increase } x1 &= n \times 0.985647 \\ \text{Acceleration } y &= exz \times \sin(x1) \\ \text{Daily fraction } n &= (c/exz) / 0.985647 \end{aligned}$$

The n-value contains the daily fraction. Thus we are able to continue calculating seamlessly on a Hildegardian basis with +1 for each following day. The result is astonishingly precise. Of course the ecliptical coordinates still need to be converted to the hourly circle, and the nutation and aberration still need to be factored in. The numbers agree almost exactly to the second with the official astronomical specifications of the celestial yearbook.¹³²⁵

The basis of calculation is a precessional computation that progresses purely mechanically, without including the nutation or aberration.

I took the *true length* of the sun on December 25th as the starting position. The daily value is sufficient for a first approximation. For an exact calculation, it would also be necessary here to determine [ascertain] the daily fraction at the time of the passage of the meridian (if equation of time = 0.000...). All the rest is obtained by the trigonometric functions of the x and y axes, as the formula in the box shows.

¹³²⁴ *Das Wahre Weltbild*, p. 153.

¹³²⁵ *Das Wahre Weltbild*, p. 154.

Thereby I have proven once more that celestial mechanics is indeed derivable from two counter-rotating circular movements! This process further supplies us with an important indication for the accuracy of the Hildegardian worldview. Why? Because the periodic acceleration phases of the sun begin at exactly the point in time after which its axis passes the zero point. They begin several days after the winter solstice, around January 5th each time, and several days after the summer solstice, around July 7. On these two days, the additional

- angular momentum = zero
- position of the axis = zero

The phase shift of the angular momentum at the winter and summer solstice results from the constant inclination of the sun's axis of about 2.83 degrees.

In this manner the Creator solved the overcoming of the dead point at the turning point in an elegant way. He slightly displaced the sun's axis from the vertical position, whereby the axis lags behind. This leads to its angular momentum not yet having reached the zero value when arriving at its turning point. Thereby the sun overcomes the turning point with its remaining speed without much effort.

If the sun's axis stood exactly perpendicular to the ecliptic, its angular momentum at the turning point would be zero, and to overcome the dead point additional energy would be necessary. This energy would be supplied at the expense of the sun's orbital speed, which is not, however, according to the mind of the Creator.

A logical corollary of the sun's circular movement is its constant distance to the Earth, of course. If the theoretical solar diameter is produced in celestial yearbooks because people are calculating using Kepler's laws, then one can confidently discard these numbers. The sun always has the same diameter because its distance to the Earth is constant throughout the entire year.

1) $dm = DtoR (2.83)$ true inclination of the sun's axis (in radian measure).

2) $b = DtoR (n \times k\text{-beg})$ number of days $\times 0.98$ degrees: true length Dec. 25.

3) $es =$ obliquity of the ecliptic.

4) $soX = ATAN (\cos(b) \times \tan(es)) \times 180/\pi$ is the ecliptical precessional motion.

5) $soY = ATAN (\cos(b) \times \tan(dm)) \times 180/\pi$ is the rotational axis of the sun.

6) $\text{soZ} = \text{round}(\text{soX} + \text{soY}, 1)$ are the $X + Y =$ position angle of the sun.¹³²⁶

Posch then cites a source showing corroboration with his findings.

One year after my mathematical studies I read in *Raum & Zeit Spezial 7* [Space & Time Special 7] a discourse about calculating planetary orbits. Therein the mathematician J. Huber proves that the revolutions of the planets can also be interpreted as a vortex. The entire study appeared in *Mathematische Physikalische Korrespondenz* (no. 144, Institut Dr. Unger, CH-4149 Dornach). We confine ourselves only to the conclusions of the mathematical results, which lead to the following statements:

It is obvious that Einstein's field theory of planetary orbits leads to the same results as Newton's mass theory...that is, the acceleration of gravity is equated with a centripetal acceleration of an orbit. The planetary system, in its action, is comparable to a huge vortex, whose center is located in the central body. Presupposing stable relations, imagine this vortex as divided into individual concentric stream tubes.

If we now keep in mind that the speed of light c , according to $gM = c^2r$, increases as the radius decreases, we can imagine, according to the Bernoulli equation:

$$c^{2/2} + p/p = \text{constant}$$

that, in the same sense, the inner pressure in the stream tubes decreases vis-à-vis the center. This pressure gradient, which points from the inside to the outside, effects a centripetal force on a planet, which corresponds to gravitational force.

It may be interesting in addition to envision the relations of a solid-state vortex, e.g., a rotating disc. Also imagine this vortex to be divided into individual circular discs and take into account that here the speed c with an increasing radius remains a pressure gradient to the outside. As is generally known, this [speed] results in centrifugal forces, which affect every voxel of the disc.

Wherever the centripetal speed gradient of the planetary vortex is locally disturbed through a conglomeration of matter, e.g., in the form of the planet, a centrifugal force joins the centripetal one, and the stationary orbit of the planet is marked by the fact that the effect of both forces keep the equilibrium for each

¹³²⁶ *Das Wahre Weltbild*, p. 156.

revolution. This result suggests that gravity should be looked at as an effect of the quantum of the spin of matter. Apparently the direction of the spin is irrelevant for gravity.

It may be of interest to review the condition $c^2 r = \text{constant}$ numerically for the solar system some time. This is to happen by means of the specifications in *Meyers Handbuch über das Weltall* [Meyer's Handbook on the Universe] (pp. 179/183).¹³²⁷

Remarkably, there is the strongest agreement between the product of the square of the average [mid-] orbital speed and the large half-axis of the planetary orbits, and the product of the gravitational constant and solar mass.

Planet	a·10⁶km	v²·a km/sec	= c²r
Mercury	57.9	47.9	1.3284
Venus	108.2	35.0	1.3254
Earth	149.6	29.8	1.3285
Mars	227.9	24.1	1.3236
Jupiter	778	13.1	1.3351
Saturn	1427	9.6	1.3151
Uranus	2870	6.8	1.3270
Neptune	4496	5.4	1.3110
Pluto	5946	4.7	1.3134

Mean value [average] = 1.3231

$$gM_{\text{So}} = 1.3234 \times 10^{26} \text{ cm}^3/\text{sec}^2$$

$$(c^2 \times 1 \text{ AE} = 1.3444)$$

In accordance with the present figures, it is possible, consequently, to calculate the planets' orbits without making use of the notion of gravity. This is apparently to be ascribed to the interpretation of the planetary system as a vortex. The question is now whether gravitation in general can be explained as a vortex effect.

Posch makes this note before the author continues:

Thus, based on the present insights, we shall attempt to describe a possible solution to this puzzle. Note: What follows is a mathematical derivation of tangential speeds on a circle. After that it says further:

¹³²⁷ *Das Wahre Weltbild*, p. 157.

Applied to the problem at hand, this means that every point of mass which, as hinted at in the mentioned essay, can be understood as the sum of space structure vortices, exists a potential vortex field, whose axis can occupy any spatial direction. Accordingly, the centripetal force of this vortex field is spherically-symmetrical with the intensity $1/r^2$, in accordance with the equation of Bernoulli, that is, it is identical with the gravitational force. In other words: The gravitational field can be interpreted generally dynamically as an effect of a space-structure movement, similar to the electrostatic field.¹³²⁸

Keplerian Anomalies

Concluding this section, Posch adds:

And that's exactly what Hildegard says! The result of this mathematical study is entirely in agreement with Hildegard's postulate, according to which the planets move around the sun on the basis of an eddy current. Gravity is a force of the winds. From them flows the potential energy that gives weight to matter and forms and builds gravitational fields. The cyclone impels the planets.

Since in the classical world of Newtonian legalities there is no circular motion that continues on its own, a circular orbit must have a force as its cause. These forces are formulated in Newton's theory of mass, whereas the ingenious gentleman left open where these forces come from.

If, then, the orbiting planets use energy (as our vehicles use fuel), then there arises the question: where do the planets get their impulsion energy? According to the first law of Kepler, the planetary orbit is dependent on the relationship of the potential energy of the planet to its kinetic energy. In other words: the spin is taken from the difference between circle and ellipse, for the sum of potential and kinetic energy is always constant. According to the law of the conservation of angular momentum and energy, the demand for energy is passed back and forth between kinetic and potential energy each time.¹³²⁹

In the perihel, E_{kin} has a maximum, E_{pot} a minimum, whereas in the aphel, E_{pot} reaches a peak and E_{kin} a minimum. Strictly speaking, this is not physics but magic, for there is never any mention of energy consumption!

¹³²⁸ *Das Wahre Weltbild*, p. 158

¹³²⁹ *Das Wahre Weltbild*, p. 158.

The First and Second Laws of Kepler apparently make our planetary system into a perpetual motion machine, though even this supposition is already prohibited by science. Nevertheless, for thousands of years the planets have been moving around the sun without any weariness and without wearing themselves out. But there is no magic in the skies. Without this cyclone, no planet would revolve around the sun. The energy comes from *it* – and not from the mass – as we have been able to prove mathematically.

Just as a wind turbine only supplies energy if the wind blows constantly, so the energy demand of the universe must be met by a constant supply of energy, i.e., through a continuous blowing of the cosmic winds. Hildegard confirms the constant supply of energy in the universe: "...for the side winds, incessantly, even if mildly, do not stop blowing air" (*Die göttlichen Werke*, 84).

This permanent blowing of the cosmic winds not only makes possible the revolution of the firmament, it also supplies the kinetic energy for the planetary movements, which do not, after all, travel around the sun free of charge. They do not receive their angular momentum reciprocally from the mass, as has been explained hitherto, but through the cyclone. The wind current that flows to it replenishes the constant consumption of energy and keeps the centrifugal and centripetal forces balanced.

Gravitational force must be redefined as vortex force, just as the superrotating disc galaxies show, which cannot be understood either with Newton's or with Einstein's theories of gravity. For the outer regions of the disc galaxies move around their galactic center a lot faster than they could be stabilized with the Newtonian gravitational effect of the inner visible star masses. This behavior can only be explained with vortex systems and their nebula vortex systems. Spiral nebulas in particular, which are very similar to our weather charts, indicate very clearly that there are eddy currents in the universe.¹³³⁰

¹³³⁰ *Das Wahre Weltbild*, p. 159.

Who shakes the earth out of its place,
and its pillars tremble;
who commands the sun, and it does not rise;
who seals up the stars;
who alone stretched out the heavens,
and trampled the waves of the sea;
who made the Bear and Orion, the Pleiades and the
chambers of the south;
who does great things beyond understanding, and
marvelous things without number.

Job 9:6-10

"The Copernican revolution outshines everything since the rise of Christianity and reduces the Renaissance and Reformation to the rank of mere episodes."

Herbert Butterfield¹³³¹

"Such as, my dear, that Christianity is dead and rotting since Galileo cut its throat."

Slote¹³³²

"All truth passes through three stages. First, it is ridiculed. Second, it is violently opposed. Third, it is accepted as being self-evident."

Arthur Schopenhauer¹³³³

"He who puts the cart before the horse can at best proceed backwards."

Walter van der Kamp¹³³⁴

"Sometimes the first obligation of intelligent men is to restate the obvious."

George Orwell¹³³⁵

¹³³¹ Owen Barfield, *Saving the Appearances: A Study in Idolatry*, 2nd edition, Wesleyan University Press, 1988, pp. 50-51.

¹³³² The words of Slote to Natalie to prove the philosophical basis (as opposed to the economic basis) for the impetus to the 20th century German revolution (Herman Wouk, *The Winds of War*, Pocket Edition, 1973, p. 610).

¹³³³ Attributed.

¹³³⁴ *Bulletin of the Tychoonian Society*, November 1982, p. 14.

¹³³⁵ Attributed.

Chapter 12

Technical and Summary Analysis of Geocentric Cosmology

By Dr. Robert Bennett

In this chapter we will analyze the arguments for geocentric cosmology with more detail and technical analysis, including the corresponding mathematical equations, charts, graphs, pictorials and technical points.

To begin, there are three geokinetic claims for terrestrial motion:

- 1) Spin claim: Earth rotates around the polar axis every day
- 2) Heliocentric claim: Earth moves around the Sun every year.
- 3) Cosmic Linear claim: Earth translates as part of a cosmic group: solar system, galaxy, local group of galaxies, etc.

We will cover each of these three claims in the following analysis.

Part 1

First we will analyze (1): the geokinetic claims that the Earth is spinning daily around its polar axis with respect to the fixed stars.

The Geokinetic Claim

All claims center on the inertial forces called centrifugal and Coriolis that explain the following effects and others based on the presumption of Earth's rotation:

1. Coriolis forces produce an East to West motion in projectiles, pendula and atmospheric winds. The Foucault pendulum and weather cyclones are examples.
2. Centrifugal forces cause the water and air near the equator to rise as inertial effects of the Earth's rotation – the polar flattening and equatorial bulge. This also explains why the acceleration of gravity is less at the equator.
3. The Sagnac effect used in laser gyroscopes and the precession of mechanical gyrocompasses indicate the Earth is spinning. Tidal braking of rotation causes the occasional adding of 'leap' seconds to the standard year.

Claims and Responses:

Claim #1: The Earth's rotation causes the inertial effects that surround it, the Coriolis and centrifugal pseudo-forces. If the Earth did not spin, these forces would not be present.

Response: All the various effects noted above depend on the assumption that the inertial effects can only be caused by the Earth's rotation. Implicitly denied is the equally valid premise that the rotation of the external world, the universe, can cause the very same inertial forces – centripetal and Coriolis. That premise is known as Mach's Principle.

Mach's idea can be stated as:

The inertia of any system is the result of the interaction of that system and the rest of the universe. In other words, every particle in the universe ultimately has an effect on every other particle.

According to Mach, the Earth in an empty universe would feel no inertial forces. Without any external reference it would be impossible to determine whether that object is rotating or not. Mach said the inertial forces on the Earth are caused by the sum of the gravitational forces from cosmic bodies such as the distant stars; the rotation of the Earth only makes sense relative to these cosmic objects.

Barbour and Bertotti proved that a large hollow sphere (representing the distant star fields) rotating around a small solid sphere inside (modeling the Earth) produced exactly the same pattern of Coriolis and centrifugal forces that are claimed as proof of Earth's spinning in space. If the hollow shell of matter accelerates or rotates, any object inside the shell will tend to be carried along with the acceleration or rotation to some extent. But they note this all-important fact: **An object at the center of the hollow sphere will not be affected by the inertial forces.** The space around the Earth will exhibit the inertial effects of the distant sphere, but not the Earth itself, if it is centrally located.

From Mach's principle we can conclude that inertia is a universal property, like gravity. But in Mach's principle the conventional interpretation of distant masses as causing inertial effects around the Earth is too restrictive. The cause of inertia could also logically be the properties of the space around each object, modified by the presence of the mass in or around that space. In other words the ether/firmament may be the source of inertia, which causes the gravity and inertial effects on bodies embedded in the ether. The ether's properties are changed by the masses (via feedback), but it is the ether that is the primary or first cause. Linear inertia is the resistance to motion of objects moving linearly caused by the ether drag.

Einstein was intrigued by, but ambiguous about, Mach's principle. This is strange, because Mach's principle states a principle of relativity for rotation, similar to Special Relativity's assertion concerning relative linear motion. An inconsistency with relativity would arise if rotational effects were not reciprocal. Distant masses would be discounted as a potent source of inertia.

No measurement of absolute or preferred rotation has been made to test whether the Earth is rotating or its surroundings. Until such a test is performed, Mach's principle is a valid statement; it has not been disproven experimentally. It is only a hurdle in the minds of those who wish it were not so.

A Simple Model

The technical explanation of gravitational and inertial forces surrounding the Earth depends on the physical concept of a field that fills the space between the interacting objects. Although the field is expressed mathematically as a function, for simplification we can picture it as invisible lines of force that terminate on the bodies, taking the Earth as one object and the rest of the universe as the other. If neither the Earth nor the universe rotated, then gravity lines from the Earth would be only vertical from the surface and there would be no inertial forces. If the Earth spins and the stars do not, then the vertical lines will be bent to produce the observed rotational effects of inertia. The picture is now of spiral or vortex lines surrounding the Earth, visually expressing the presence of horizontal inertial forces. The greater the rotation, the greater the deflection of the gravity lines sideways. Using the field concept of force lines allows us to picture how an object moving above the Earth knows that the Earth is rotating beneath it. All of this is conventional physics, for which there is no dispute.

Conventional physics, however, claims this is the *only* model of rotational reality. It does this by ignoring role reversal – the consideration that the Earth could be at rest and the stars in rotation around it. Logically, the gravity lines, like a string, have two ends. One end is at the Earth's surface and the other on one of the distant stars. If the remote stars rotate, their gravity lines connected to Earth will also bend, creating the same spiral pattern as when the Earth rotates. This model will explain the measured inertial forces just as well as the rotating Earth model.

To satisfy the scientist, this visualization of relative rotation must have formal mathematical support, or what is known as a “formal proof.”

Formal Proof

Newton's concept of absolute space pictured the fixed star shell as being approximately at rest as viewed from Earth. Newton sought to test his concept of absolute space using a water bucket to simulate the Earth in rotation. When the water in the bucket was not in rotation, the surface would be flat, since there were no centripetal inertial forces present. When the water rotated, centrifugal forces would push the water surface up the bucket sides to form a parabola. This was a simple but crude way of detecting rotation, equivalent in purpose to the present day optical gyroscope. Since Newton's absolute space was thought to be unobservable, only rotation with respect to the fixed star shell could curve the water surface. Newton thought that if the Earth were not rotating with respect to his absolute space, the water surface would be flat. There would be no inertial forces.

Berkeley and Mach held a contrary view. From their geometrical point of view, it matters not if the Earth is rotating and the star shell is at rest, or the converse. The same forces of inertia (Coriolis and centrifugal) exist for both. Mach's geometrical point of view was that relative rotation was reversible; it does not matter if the Earth is rotating and the star shell is at rest, or the stationary Earth is surrounded by the rotating star shell. Newton's mechanics is asymmetric but Mach said that a correct theory of mechanics should not break the symmetry of rotational viewpoint. Newton's equations have physical meaning only with the existence of the fixed star shell. The fixed star shell is needed to establish when centrifugal forces will be produced.

This leads us to the premises of the formal proof:

1. The Earth rotating uniformly with respect to the stationary star shell with angular velocity ω produces forces of inertia (i.e., Coriolis and centrifugal forces).
2. The star shell uniformly rotating with respect to the stationary Earth with angular velocity ω produces a constant homogeneous, vector, magnetic-type gravity (MTG) or gravitomagnetic field, described by the vector potential

$$\mathbf{A} = (\mathbf{B} \times \mathbf{r})/2$$

where \mathbf{B} is gravity's induction vector (not the magnetic field). The vector cross product indicates that the MTG field is orthogonal to both the position vector \mathbf{r} and \mathbf{B} .

What we must prove:

The equation of motion of a body in a spherically symmetric gravity field and in constant homogeneous MTG (magnetic-type gravity)

field, described by means of \mathbf{A} , is exactly the same as an equation of motion for this body in the same gravity field in the coordinate system uniformly rotating with respect to the stationary fixed star shell with $\boldsymbol{\omega} = (\mathbf{B})/2$.

The Lagrangian for the inertial body with an Earth spinning at $\boldsymbol{\omega}$ and the fixed star shell is:

$$\mathcal{L} = (m/2)\mathbf{v}^2 + m\mathbf{v} \cdot (\boldsymbol{\omega} \times \mathbf{r}) + (m/2)(\boldsymbol{\omega} \times \mathbf{r})^2 - mV$$

$V = GMe/r =$ gravity potential; $Me =$ Mass of Earth

The variational equation of motion is:

$$d(m\mathbf{v})/dt = -2m(\boldsymbol{\omega} \times \mathbf{v}) - m[\boldsymbol{\omega} \times (\boldsymbol{\omega} \times \mathbf{r})] + m\mathbf{E}$$

where $\mathbf{E} = -\mathbf{grad}V$, $-2m(\boldsymbol{\omega} \times \mathbf{v})$ is the Coriolis force, $-m[\boldsymbol{\omega} \times (\boldsymbol{\omega} \times \mathbf{r})]$ is the centrifugal force. The Lagrangian for the inertial body “m” with a star shell spin of $\boldsymbol{\omega}$ and the Earth stationary is:

$$\mathcal{L} = (m/2)\mathbf{v}^2 + m\mathbf{v} \cdot \mathbf{A} + (m/2)\mathbf{A}^2 - mV: \quad V = GMe/r$$

The variational equation of motion is:

$$d(m\mathbf{v})/dt = -m(\mathbf{v} \times \mathbf{B}) - m/4[(\mathbf{B} \times \mathbf{r}) \times \mathbf{B}] + m\mathbf{E}$$

If the condition for relative rotation is chosen, $\boldsymbol{\omega} = \mathbf{B}/2$, the motion equations in both views are identical.

Physical Constituents of a Geocentric Universe

Key preliminary concepts

- Ether
- Parallax vs. aberration
- Parallax vs. transit delay
- General covariance
- Occam's razor

Definition of Ether:

Ether (a) fills all space, (b) is more rigid than steel, (c) is more flexible than any known substance. These three properties allow connection to be made between ether and the Genesis firmament (Gn 1:6-9), which has the following characteristics as noted in the text analysis.

- Ether is the medium for propagating electromagnetic waves.
- Ether is a “less dense” (lacking a definition, an appeal to physical intuition) material form of matter, a fluid of photon quanta.
- Light speed is only constant in relation to the medium and its properties, such as density.
- The density of ether is related to gravity as Einstein's view of the solar eclipse is related to the bending of light through air of differing temperatures.
- Ether can be dragged along – entrained – with matter, proportional to Fresnel's drag coefficient.
- Modern cosmology's invention of Dark Matter is the result of its dismissal of a pervasive universal ether and the differing densities of ether.

Possible Suppositions/Conclusions:

The possibility of ether-matter drag provides the reason for very small measurements from precise interferometer experiments. Ether might have a liquid crystal structure to account for transverse wave propagation. The transmission of energy and radiation is affected by the density and flow of ether.

Types:

- (a) Electromagnetic or luminiferous: the only one treated here.
- (b) Gravitational or ponderomotive: related directly to the firmament, but left undeveloped as a very broad topic. Merits future detailed exposition.

(c) Static Magnetic: may be related to the other two

Modern possibilities:

- (a) The zero point energy (ZPG) and fluctuations (ZPF) of the quantum vacuum
- (b) The vast sea of neutrinos
- (c) The virtual particles of quantum field theory
- (d) Particles of Planck length
- (e) The EPOLA - an alternating lattice of electrons and positrons
(see: Theories of the Ether¹³³⁶)

Zero drag: Ether that is totally unaffected by a gravitational field is called “unentrained,” meaning without any drag or friction. Objects like the Earth would move through ether without dragging any along. The unchanged flow of ether through the Earth (or vice-versa!) would allow Measurement of any motion around the Sun (revolution) or spin (polar rotation). As will be shown, the Michelson-Morley experiment was able to detect such an ether wind of revolution at 0.01% of c and a small non-null result was found, but not to the level expected for an unentrained ether.

Partial drag: If the ether is partially entrained, Earth’s gravity field would make it denser at the Earth’s surface than at higher altitudes, similar to the atmospheric density variation. The partially dragged ether would be traveling at a fraction of the Earth’s revolution speed. A small level of drag would produce a small but non-null change in the relative velocity between the Earth and the ether. Detection of this small change by any laboratory experiment, like the Michelson-Morley experiment, would depend on the instrument sensitivity.

Total drag: Complete entrainment of the ether by the Earth is a special case of partial dragging, with the dragging factor equal to 1. No relative motion between ether and earth will be detected, since the ether is moving (being dragged) at the same speed as Earth’s speed.

Models: Picture still water as ether and a swimmer as a light photon. When riding in a boat, a person moves with the speed of the boat. Diving into the water (ether) the swimmer (photon) can only swim at his physical limit. Once out of the boat the swimmer has the speed and direction of the dive, which is independent of the boat’s velocity. If the water gets muddy (thicker), the swimmer’s speed slows according to the density of the water (ether). The ether thus determines light speed, not the velocity of the source.

¹³³⁶ <http://www.mountainman.com.au/aether.html>

As an analog of drag in an elastic/flexible ether, consider a car's motion through air, with the car modeling the Earth and the ether. If the road serves as an absolute reference frame – an alternative form of a rigid and immobile ether – the speedometer always measures the true absolute speed of the car along the road (i.e., Earth with respect to the absolute frame).

- No drag: an open convertible - the air streams past the driver with no interaction - the air stream measures the true car speed.
- Partial drag: car with a window open - some of the air is trapped inside and forced to move with the car.
- Total drag: all windows are closed - all the air is forced to move with the car.

History of light and ether:

Newton's particle theory of light explained reflection but not wave phenomena, such as refraction and diffraction. He proposed the existence of an "ethereal medium" – simply called ether - with these properties:

- it supported vibrations faster than light.
- its particles are much smaller than those of air or the light particles.
- much thinner and flexible than air.
- offers little resistance to object motion (friction).
- able to exert pressure on objects by expansion.

Bradley's stellar aberration could be caused by the Earth's movement through the ether. Starlight could be bent in the ether and hit the Earth at an angle, moving the image of the star.

George Stokes thought ether might be rigid for high speeds and fluid at lower, like tar at cold and hot temperatures. Slow objects could penetrate it easily, but not light.

Fresnel proposed the following:

- ether is at rest in free space.
- ether density is different in different substances.
- speed of light in any substance varies inversely as the square root of the ether density.
- light waves are propagated in the free ether in any direction, always with the same velocity with respect to the ether.
- Earth in its motion in space passes freely through the ether without disturbing it.

In general, 19th century physicists thought there was an absolute ether; the dragged ether was denied. The absolute ether was at rest while all cosmic objects moved through it. The motion of the Earth and the motion of an absolute ether are tied together logically. Only if the Earth is at rest in the absolute ether can light travel with equal speed in all directions (isotropically). If the Earth is moving in the absolute ether, the measured speed of light cannot be isotropic. Other possibilities include a fixed Earth and a mobile ether.

Ether as wind:

In the heliocentric model, the Earth travels through the ether in its orbit around the sun at a speed of about 30 km/second. A detectable “ether wind,” varying with time of day and season, should produce components due to Earth’s motion relative to the solar system that are separable from the overall motion of that system. The ether effect on light would be like the wind effect on sound.

Ether and rotation:

Recent experiments show that a rotating object has unexplained mechanical anomalies compared to a non-rotating one.

- 1) Rotating objects falling in ether accelerate faster than ‘g’, the free fall value for non-rotating objects in a vacuum.
- 2) Pendula with rotating bob weights deviate from harmonic motion, with lower frequencies than pendula with non-rotating bobs.
- 3) A precessing gyroscope has inertial mass greater than its gravitational mass.
- 4) If a gyroscope is forced to precess by applying an external torque, objects placed around the gyroscope cause it to exhibit an increase of inertia.

Besides supporting the ether concept, these experiments can be verified with simple equipment and precision clocks.

Geocentrism based on ether flexibility:

Geocentrism has two options for the transparent ether, either rigid or flexible/plastic, with either one perhaps different from Maxwell’s luminiferous ether. A null result from the Michelson-Morley experiment implies a stationary Earth embedded in this rigid ether, the absolute reference frame. However, any non-null result (as in the Dayton Miller and all later interferometer experiments) would imply that the ether is

flexible and that the premise of rigidity is incorrect, not that the Earth moves through the ether.

Although cited as having a null result for detecting the ether-Earth motion, careful analysis of the Michelson-Morley experiment by Maurice Allais and others has shown that there was a small but detectable fringe shift measured with the Michelson-Morley interferometers, consistent with the later observations with improved apparatus. The non-null results eliminate the rigid ether as a possibility, so the Earth is the only fixed object, immersed in a universal flexible ether. Hence, Mach's principle can be applied with two options:

- 1) The ether is fixed and contains a rotating shell of distant matter that provides for the attractive forces needed to explain and synchronize the daily, monthly and yearly celestial motions, as well as explain the local inertial forces near the Earth. All objects move through the ether, except the Earth.
- 2) The ether is flexible and rotating, providing the forces needed to explain and synchronize the daily, monthly and yearly celestial motions, as well as explain the local inertial forces near the Earth. The rotating ether carries the heavenly objects around the Earth, like boats in a whirlpool.

In view of the Michelson-Morley-type experiments (correctly interpreted) the rigid ether was rejected, so option 1 above is eliminated. Thus, the geocentric model is a rotating invisible ether causing all cosmic objects to perform all the motions observed from Earth. It is this ether type that is meant by the "firmament" of Genesis 1:6-9.

In order to synchronize all cosmic motions, the firmament must be able to transmit changes in location and motion across the universe at least as fast as gravitational changes, which have a lower limit of $2 \times 10^{10}c$, or 1,860,000,000,000,000 miles per second. The speed may be higher.

Ether flux and celestial motions:

Etherometry proposes that the rotational and translatory movements of planets, stars and galaxies are the result of spinning motions of ether vortices ordered in a hierarchy. Ether flows and vortices are associated with each star, planet, moon, and the sun, as well as groupings such as clusters and galaxies and the Milky Way. Simply put, ether that flows toward the Earth from deep space imparts downward impulses on the Earth (gravity), while the spin of the Earth's ether vortex causes the inertial forces of centrifugal and Coriolis forces.

Ether motion around the Earth can be deduced from satellite motion, since ethereal rotational motion around an object sustains orbital motion. The translational speed of a satellite is zero at the geostationary

distance of 22,000 miles above the Earth. It increases steadily to 18,000 mph at low earth orbit of 70 miles, then decreases sharply at lower altitudes with atmospheric absorption of the ether flow, so that at tropospheric altitudes it will either be moving with or causing the jet stream of up to 200 mph.

The slight west-to-east rotation of the ethersphere at the Earth's surface accounts for the results of Sagnac-type experiments which have shown that the speed of light is slightly faster around the Earth from west to east than from east to west. Moreover, the almost vertical descent of the ether flux at very low altitudes explains the apparent vertical motion of free fall. A free falling object is slightly swept eastward by the ethereal rotation, an effect only noticable for high falls or with precision instruments.

Modern science presumes the absolute motion of the earth to be the result of two independent motions: (a) the orbital motion around the sun at 30 kilometers per second, (b) and the cosmic motion of the sun and the solar system. Some ether drift measurements indicate motion of the solar system towards the constellation Hercules at a speed of 19 kilometers per second, which is claimed to be only relative motion of the sun with regard to nearby stars.

In order to subtract the Earth's revolution and rotation, the ether-drift effect must be monitored continuously over twenty-four hours and at three or more months of the year. The direction of the orbital motion could not be identified in the monthly curves, which is interpreted as indicating that the orbital component is probably much smaller than the cosmic component. This phenomenon can also be interpreted as indicating the Earth has no orbital motion, but this is not acceptable to the modern cosmologist. Note also, as the Michelson-Morley experiment shows a slight drift, modern cosmology interprets it as a null result; and when the ether drift shows no orbital component, a null result, it is assumed to be non-null!

When plotted against sidereal time, a marked consistency was shown in the readings for the azimuth and magnitude, as though they were related to a common cause. The curves showed conclusively that the observed ether effect is:

- Dependent upon sidereal time.
- Independent of diurnal and seasonal changes of temperature and other terrestrial causes.
- Thus independent of the Earth's alleged rotation and revolution.
- A cosmic phenomenon.

The conclusion stated that there is a positive, systematic ether-drift effect, corresponding to a *constant* relative motion of the Earth and the ether, with an apparent velocity of ten kilometers per second toward

the north pole of the ecliptic, having a right ascension of 17 hours and a declination of $+65^\circ$.

The Stokes ether concept (that the ether is partially entrained by matter moving through it), suggests that the observed velocity of ten kilometers per second might be only a fraction of the absolute velocity; that the actual velocity of the cosmic motion might be two hundred kilometers or more, per second. A first approximation to the velocity of the cosmic component of motion was found to be 200 kilometers per second.

Reduced velocity and displaced azimuth are unexplained. The observed effect is presumed to be of second order in v^2/c^2 and the ether is wholly stagnant and undisturbed by the motion of the Earth through it.

Two unexplained facts of ether-Earth motion remain:

- The fringe displacement has always been less than was expected, indicating a reduced velocity of relative motion, as though the ether through which the interferometer is being carried by the Earth's motion was not absolutely at rest.
- The direction of the cosmic motion should swing back and forth across the north and south line once in each sidereal day because of the rotation of the earth on its axis. This is not observed.

Ether and Relativity:

The principle of relativity, which was first formulated by Poincaré, stated that no motion experiment in the universe can detect a point of absolute rest or a preferred direction. Motion and rest are arbitrary choices of definition. The equivalence of all directions is called spatial isotropy.

All reference frames moving relative to each other with constant velocity in a straight line are called inertial reference frames (IRF). The relativity principle is equivalent to saying that there is no absolute or preferred inertial reference frame - the laws of motion are equally valid in all.

Calculations of dynamics from the time of Galileo to Einstein used Galilean relativity:

- The velocity of an object is added to the vector velocity difference between the two reference frames – a Galilean transformation.
- The geometry of space is assumed to be Euclidean (flat or not curved). Light travels in straight lines in Euclidean space.
- The geometry of space is assumed to be Euclidean (flat or not curved). Light travels in straight lines in Euclidean space.
- Time is absolute – the same for all observers.

Galilean relativity was the basis for the laws of Newtonian mechanics but it did not hold for the electromagnetic laws of Maxwell that involved relative motion. Maxwell's laws assumed a luminiferous ether medium for the electro-magnetic radiation, which led to forces dependent on the object's velocity. Thus, combining Maxwell equations and the Galilean transformation allowed an absolute velocity with respect to a preferred frame of reference, the ether. If the symmetric Lorentz transformation of Special Relativity theory is used to change inertial reference frames, the Maxwell equations will still be consistent, since Special Relativity theory has no ether. Special Relativity theory had restored the dynamical equivalence of inertial reference frames for electromagnetism. The null results for ether motion predicted by Special Relativity theory made the ether irrelevant and unnecessary. Now position in space or time was not absolute, but measurements depended only on the observer's speed.

But new problems arose. Time now became relative; observers in relative motion could not agree on their clock readings or on whether events were simultaneous. The human intuition of a universal time had to be abandoned. More seriously, the divine delegation of absolute and universal timekeeping to the motion of the heavenly lights in Day Four of creation was disregarded.

Light measurement differed from that of matter because light travels in the universal ether frame. Sounds in an airplane travel along with the air inside the aircraft and obey the Galilean transformation. But a light beam in the plane would not. It would show some effect of its motion in the universal ether.

What and where was the special coordinate system at rest in the ether? Maxwell had measured electro-magnetic properties of empty space, the ether vacuum, including its resistance of 377 ohms. As a heliocentrist he noted that the "drift" of Earth through the ether should be found in the annual changes of the Earth's motion around the Sun, or the daily variation of rotation (although these changes were 60 times smaller than the yearly changes). This was the motivation for the Michelson-Morley experiment.

Some physicists realized that a number of problems in modern physics would be simplified with the ether concept. Others said the ether makes it difficult to explain modern experiments. In reality, it is only true if the immobile Earth is rejected as a possible cause, a latent premise in experimental interpretation continuing to this very day.

Relativity contains many paradoxes, some based on Einstein's changes in belief. He simultaneously proposed that in Special Relativity there is no ether, yet in General Relativity space is curved by nothing. His position on ether depends on the date. From 1905 to 1915, the age of Special Relativity, there was no need for ether. From 1915 on, in the age of General Relativity, he states: "we may say that according to the general theory of relativity space is endowed with physical qualities; in

this sense, therefore, there exists an ether” [NB: but there is no other sense in which to understand the ether]. “According to the general theory of relativity space without ether is unthinkable.”

Of course the rejection of relativity is inherent in the acceptance of geocentrism. Some objective physicists are only now realizing from other astronomical evidence that a viable possibility to explain the Michelson-Morley experiment is that the Earth is stationary in the universe. Yes, the dreaded word – geocentrism.

Parallax versus Aberration:

The ellipse patterns formed by parallax and aberration are similar and, indeed, are superimposed for nearby stars. But the two stellar effects can be separated, as discussed below in heliocentric terms.

Because of the yearly change in position of the Earth, the direction in which a star is observed changes annually. Unlike aberration, the parallax angle is proportional to the ratio of the diameter of the Earth’s orbit to its distance from the star. Bradley observed a different periodic variation in the apparent position of stars, reflecting changes in the velocity rather than in the position of the Earth over the course of a year.

Transit Delay versus Aberration:

A light beam on the left shines toward a target, such as Earth. Far to the right are two stars for direction references. For aberration – shown at the bottom – the target Earth is at rest. Light travels from the original position of the source toward the bottom star, reaching the target when the source is opposite the Earth. The aberration angle between the original and final positions of the source is the angle between the two stars.

Transit delay is shown in the top diagram for a stationary source and moving target, a view just as valid as the bottom, by the principle of relativity. To hit the target, the beam must be sent in the direction of the top star when the target lines up with the bottom star. Hunters call this “leading the target.” By geometry this leading angle, due to transit delay, is the same as the aberration angle in the bottom diagram.

General covariance:

In theoretical physics, **general covariance** is the invariance of the form of physical laws under arbitrary coordinate transformations. The principle was formulated by Einstein who wanted to extend the Lorentz covariance in Special Relativity to non-inertial frames in General Relativity. All physical theories such as mechanics and

electrodynamics must necessarily have a generally covariant formulation.

Physics dabblers will sometimes claim that astronomical observations must be made from a heliocentric point of view. They insist that the use of a geocentric coordinate system will not correctly describe celestial motions, events and alignments, like occultations and eclipses. This point of view – never raised by professional scientists – reveals a failure to recognize the difference between the intrinsic *physical* properties and relationships of a system (which exist independently of any description of it) and the arbitrary *mathematical* coordinate system used to describe the system.

The location of a point on the Earth's surface can be equally described with Cartesian, spherical or elliptical coordinates with the origin at the Earth's center. The system may have a symmetry which matches that of the coordinate system and simplifies the mathematical clutter used in its description (such as the spherical coordinates and the Earth). Nevertheless, any reasonable coordinate system may be used. The weave pattern of a net does not determine the shape of the objects that can be put into it.

Occam's Razor:

*Given two equally predictive theories, choose the simpler, or
The simplest answer is usually the correct answer.*

This philosophical advice of Occam was extended to choosing competing physical theories when they could not be separated by reason or experiment. An example often used is General Relativity theory versus all its proposed alternative theories. When expressed in geometrical terms, such as the curving of space as a ball does when placed on a trampoline, or when the dynamics is expressed as one single tensor equation, General Relativity theory is said to be the simplest of theories, and appeal is often made to its mathematical "beauty." Thus, we see that even aesthetic judgements are employed, as opposed to objective ones.

A problem is being ignored in the General Relativity theory example, however. General Relativity's equations expand to 10 non-linear differential equations, which are usually intractable to solve precisely, except for the simplest symmetrical models. The computations are far from beautiful; they are horrendous. Occam's razor can hide complexity in a veneer of deceptive simplicity.

Generally speaking, there are also other issues. A fully open epistemology accepts more sources of truth than does science, such as divine revelation. Whenever revelation – which is the word of the infinitely simple God – overlaps science, it trumps Occam's Razor.

Science ignores this freely given gift of truth at the risk of giving an unnatural interpretation of nature.

Occam's razor is often implicit in many interpretations of modern science when an effect/experiment can be explained by more than one cause. No more is this true than in saying the stars are fixed and not rotating, since the opposite view requires that the entire cosmos is focused on Earth, as Scripture describes. To be geocentric is to be theocentric, a challenge of faith that modernists will not accept.

Geocentrism assumed an ether, a preferred frame, and a universal time. Einstein's Special Relativity theory did not. But none of the following eleven independent experiments, which were said to confirm Special Relativity experimentally, can distinguish Relativity from Geocentrism, or from the ether theories of Lorentz or Hatch:

Bradley	Kennedy-Thorndike
Fresnel	Ives-Stilwell
Airy	Frisch-Smith
Michelson-Morley	Hefele-Keating
De Sitter	Global Positioning
Sagnac	System

Note the following data:

[Key: ✓ = supported; 0 = neutral or does not apply; X = disproof]

G = Geocentric

H = Heliocentric

E = Ether

S = Special Relativity

R = General Relativity]

Typographical Notes: On the one hand, a checkmark (✓) for an experiment does not indicate a proof or confirmation, as those who should know better claim. All empirical evidence is inductive, increasing the probability of the theory's validity, but never excluding future improvement or even abandonment. On the other hand, an "X" in any column for a theory requires responses to remove it, otherwise there is no rational reason to maintain a paradigm that cannot explain one or more experimental results within its scope. Only experimental evidence and common experience are investigated below. Theory is discussed as it pertains to the experiment.

The first row is the consensus scientific opinion, which is often far from unanimous – especially in the interpretation of results by relativists. This also holds for the summary columns. The second row of each experiment is the geocentric view.

Experiment	Type	G	H	E	S	G
Foucault pendulum 1851	If a simple pendulum suspended from a long wire swings along a meridian, the plane of motion seems to turn clockwise in the Northern Hemisphere and the reverse in the Southern Hemisphere. This shows the axial rotation of the earth around the poles. A Foucault pendulum precesses clockwise with an angular frequency of $\omega \sin \theta$, where θ is the latitude and ω is the angular frequency of the Earth's rotation.	X	✓	0	0	0
Geocentric Response	The assumption underlying this experiment is that the effect seen can only be caused by the Earth's rotation with respect to the stars. Mach's principle proves otherwise; relative rotation will cause the same result. Note that the period is sidereal, showing it is the stellar motion, not the sun, that causes the pendulum's rotation. The periodic energy source needed to sustain motion is typically an EM device. The motion is thus contaminated - not solely due to forces of gravity and inertia, but also of the EM field, which must be compensated for.	✓	0	✓	0	0
Sagnac 1913	To detect the relative motion of the ether, Sagnac placed the Michelson-Morley apparatus on a constantly rotating turntable. He detected a clear non-null result – light speed depended on rotation – evidence for ether. The light source (a flashlight), the measuring device (an interferometer) and the photographic recording plate were all fixed to the rotating disc. An observer on the disc thinks that the light has completed one revolution of the disc ($2\pi r$) at velocities of $c \pm v$ in the two opposing directions.	X	0	0	✓	0
Response	Sagnac shows that light speed does <i>not</i> remain constant relative to the motion of its source or observer/detector. The reasons given for this contradiction to Special Relativity in turn contradict Special Relativity. The proof of ether and disproof of Special Relativity theory is purportedly denied using General	✓	X	✓	X	X

	Relativity theory to arbitrarily add a universal reference frame (“proper time”), which is exactly what ether is!					
<u>Michelson-Gale-Pearson</u> 1925,1929	A variation of Sagnac’s test on a much larger scale that detected the Earth’s rotational motion, consistent with an ether medium. The aim was to find out whether Earth’s rotation effects light speed near the Earth. The outcome: the angular velocity of Earth is confirmed within measuring accuracy. The measured shift was 230 parts in 1000, with accuracy of 0.5%. The predicted shift was 237 parts in 1000.	X	0	✓	✓	0
Response	Everyplace that Earth’s rotation is mentioned in physics texts can be replaced by ether rotation around an immobile Earth, by Mach’s principle. The significance remains debated to this day, but the planetary Sagnac effect is now measured by ring laser gyros and taken into account by the Global Positioning System.	✓	0	✓	X	0
<u>Ives-Stilwell</u> 1938	Classic experiment that measured the transverse Doppler effect with sufficient accuracy to confirm time dilation for moving atoms – that velocity slows the rate of a moving atomic clock. This first experimental proof of time dilation measured the Doppler-shifted frequencies of an emission line from hydrogen ions in parallel and reverse directions.	X	0	0	✓	0
Response	Ives argued from this result that ions radiated at frequencies determined by absolute, not relative, motion, because they had to pick a specific frequency in which to radiate. This directly supports the ether theory and geocentrism indirectly.	✓	0	✓	X	0
<u>Hefele-Keating</u> 1971	Atomic clocks depend on rotation of the Earth. Atomic clocks flown around the world exhibit changes that agree with relativity predictions to 10%. Total time differences from general and special relativity effects were predicted to be +275 ns westbound and –40 ns eastward. The vast majority of scientists think it is	X	0	0	✓	✓

	irrefutable evidence of time dilation and relativity.					
Response	Rotation observed indicated a preferred reference system. Why did the H&K test cause a real and permanent physical change in the readings of the traveling atomic clocks? If the Lorentz transformation changes in length and time were a mere phenomenon of the relative motion, then when the relative motion ceased, so would the changes. But it was not so.	✓	X	✓	X	X
<u>Global Positioning System</u> 1993+	Global Positioning System (GPS) – the Earth’s only fully functional satellite navigation system. Global Positioning System needs universal synchronization of satellites and ground stations; the preferred reference frame is the ECI reference frame. Satellites broadcast precise timing signals to ground receivers to determine their location accurately. Relativity is tested by the orbiting and ground atomic clocks at varying altitudes and high relative speeds.	X	0	0	✓	✓
Response	The Global Positioning System’s daily operations support Geocentrism and challenge Relativity dogma. All high precision GPS applications correct for the Sagnac effect, indicating that the speed of light is not always constant to the moving observer. The Sagnac effect in the GPS operations are in conflict with relativity theory. GPS computations locate moving receivers by including the $v \pm c$ Galilean model. ECI is the standard technical name for the Geocentric frame.	✓	X	✓	X	X
<u>Global Air circulation</u>	Global air patterns are explained by thermal heating and the Coriolis force, which deflects air rotating with the Earth to form west to east airflow.	X	✓	0	0	0
Response	Let’s generalize the vortex motion of tornados, hurricanes, typhoons and cyclones to the whole atmosphere itself. We would think that the rotating Earth would drag along the air right at the surface, but the lack of friction and viscosity of air, plus its inertia, would make the air stream behind the ground’s	✓	0	✓	0	0

	<p>motion, form as swirls of cream in a coffee cup. At the equator, which spins at 1054 mph, there would be a rapid change in the wind profile, from zero on the ground to 1054 mph at high altitudes. Testing our belief with anemometers we are surprised to learn, however, that the equatorial winds are quite docile, random and calm, even at heights. Only the sun's heat, as it crosses the sky (literally), provides gentle breezes. Using Galilean reasoning we might say: Aha! There's no atmosphere! Moderns, having made great advances in natural understanding, we laugh and say, incredibly, that the whole atmosphere co-rotates with the Earth, as if the air were solid! Theists, with a geocentric mind, say with Scriptural simplicity: "Of course there is no wind – the Earth is fixed forever. It was God who told us so.</p>					
--	---	--	--	--	--	--

Foucault pendulum:

Conceived as an experiment to demonstrate the rotation of the Earth; the motion of the Foucault pendulum is a result of the Coriolis effect. It must be long and free to swing in any vertical plane. The first Foucault pendulum exhibited to the public was in 1851 of the Paris Observatory. It was the first dynamical proof of the rotation in an easy-to-see experiment.

At either North or South Pole, the plane of oscillation of a pendulum remains pointing in the same direction while the Earth rotates underneath it, taking one sidereal day (23 hours 56 minutes) to complete a rotation. Placed at the equator the plane of oscillation rotates with the Earth, so there is no apparent rotation. Other latitudes produce partial rotation.

If n = degrees per day and ϕ = Latitude angle, then

$$n = 360^\circ \sin \phi$$

To view the swings for a full day the pendulum should include a periodic source of input energy to overcome air friction and resistance at the point of support.

Sagnac Effect:*Experiment design:*

The Sagnac interferometer uses ring interferometry to split a beam of light. The two beams travel around the ring in opposite directions and produce an interference fringe pattern when they overlap. The ring interferometer is located on a rotating platform whose interference lines are shifted sideways when compared to the platform when not rotating. The shift sideways is proportional to the angular velocity of the rotating platform. During rotation the points of entry and exit move while the light is propagating so that the beam moving opposite to rotation covers less distance than the co-rotating beam. The pattern found with each angular velocity has a phase-shift corresponding to that angular velocity.

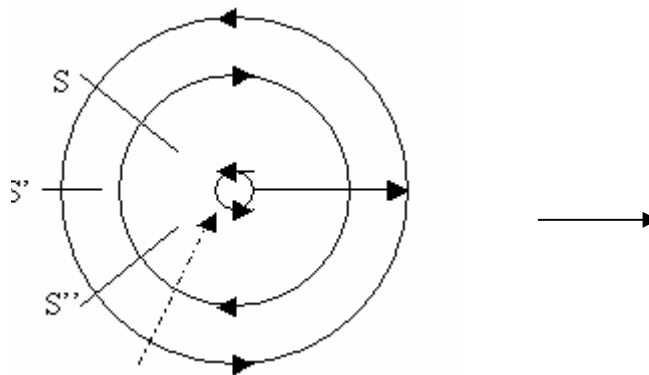
**Sagnac apparatus turning clockwise:**

The counter-clockwise beam in the diagram above opposes the rotation of the platform and returns to the light source when the source is at S'. The second beam, traveling clockwise with the direction of rotation of the equipment, returns to the light source when the source is at S''. Seen by an observer on the spinning platform, the light signals return to the same point, but at different times. Points S and S' are points on the fixed laboratory desk, as they would be marked beneath the spinning disc by a stationary observer in the laboratory.

If t_0 is the time when the disc is at rest, i.e. the path length divided by the speed of light, then:

$$t_0 = 2\pi r/c$$

The time t' , as observed aboard the spinning disc, for the counter-rotating beam to complete a circuit, is:

$$t' = 2\pi r/(c + v)$$

where v is the speed of a point on the periphery of the disc with respect to the axis of spinning. The time t'' , as observed aboard the spinning disc, for the co-rotating beam to complete a circuit, is:

$$t'' = 2\pi r / (c - v)$$

The time for the counter-rotating light to circle the ring is less than when stationary, so this beam is superluminal. The co-rotating beam takes a longer time to traverse the circle, so its speed is subluminal. In either case the speed of light exhibits anisotropy, contrary to Special Relativity.

For small values of v , t' is t_0 : As v approaches c , t' becomes $t_0/2$, and the speed relative to the observer becomes $2c$. As the speed v approaches c , dt'' becomes infinite, because the light and point S are traveling in the same direction and the time for the light signal to gain one complete circuit on the point S is infinite, while the observer sees the light speed approach zero.

Sagnac found a fringe shift resulting from the difference in travel times and lengths having the size:

$$\Delta n = 8\omega r^2 / c\lambda$$

Alternatively, in terms of the time difference and the area of the loop A ,

$$\Delta t = 4A\omega / c^2$$

At only two revolutions per second, Sagnac found that absolute rotation could be measured.

In a ring laser, the light is generated and sustained by including laser excitation in the path of the light. When a ring laser is rotating, the different effective paths of the two opposite-moving laser beams generate two frequencies with equal number of cycles. A standing wave is created in the ring laser which is always stationary with respect to the local inertial frame of reference – the laboratory – whether the laser is rotating or not. If the ring is rotated, the nodes of the standing waves can be recorded as they pass by an observation point. Interference of the two laser frequencies forms a beat frequency, the difference between the two counter propagating modes. The beat frequency period varies linearly with the angular velocity of the ring laser with respect to the local inertial frame of reference.

$$\Delta f = 4A\omega / \lambda P$$

ω is the angular rotation of the Earth.

λ is the wavelength of the light.

P is the perimeter of the ring laser.

The speed of the passing nodes in the ring laser test depends upon the shape of the ring, not the area. In all cases – circle, square, triangle, etc., the velocity of the passing nodes is directly proportional to the rotation rate.

The development of the ring laser has led to a far more accurate method of measuring the Sagnac effect with no moving mechanical parts. Sagnac's interferometer accuracy of 10^{-2} has been improved by 18 orders of magnitude to 10^{-20} by Bilger with a ring laser.

Applications:

Synchronizing clocks all over the globe using radio signals must take the rotation of Earth into account. In relaying timing signals with ground stations or satellites completely around the world, the time-keeping must synchronize. Without rotation, the time delay between relay points is determined by the separation distance alone. On the rotating Earth, the receivers move during the signal transit time, affecting the total time delay. The need to include Earth's rotation for synchronization is called the Sagnac effect.

The Optical Laser Gyroscope uses the temporal difference between forward and reverse beams to measure rotation, a phenomenon that contradicts Special Relativity. Einstein always considered the Optical Gyroscope to be theoretically impossible.

Commentators:

Herbert Ives states:

[if the observer's] apparatus rotates with respect to the stars he will observe a Sagnac effect, if it does not, then no matter how great a relative rotation it exhibits with respect to its material surroundings, there will be no effect.

The key condition is that the equipment rotates relative to the stars. Since Ives doesn't specify that the stars are "fixed," his principle is consistent with Mach. The Sagnac effect is present whether we view the stars as stationary and the apparatus as rotating, or whether we view the apparatus as stationary and the stars as rotating. As it stands, Ives showed that Special Relativity theory cannot explain the Sagnac result. The same etherless Special Relativity theory that explained why the Michelson-Morley experiment detected no terrestrial motion around the

Sun would also predict that the Earth should not seem to rotate, there being no ether to rotate in.

Michelson wrote:

...this result [Sagnac] may be considered as an additional evidence in favor of relativity - or equally as evidence of a stationary ether.

That is, an immobile Earth in a Machian universe.

Note worthy is the fact that no reference by Einstein to the Sagnac tests is known, even though it was done eight years after Special Relativity was published, in addition to the fact that the results bear greatly on the validity of Special Relativity theory. Silberstein remarked,

As a matter of fact, Einstein himself never entered into the details of this important problem of rotation....In fine, the optical circuit experiment may easily become crucial and fatal for Einstein's theory.

Turner (1979) commented that neither the Sagnac tests nor the Michelson/Gale tests were ever mentioned by Einstein. Post (1967) saw that there was a conflict in Special Relativity theory between the treatment of straight-line motion versus the rotating disc:

To be consistent with the principle of relativity one has to demand that the Sagnac interferometer and the ring laser cannot lead to a fringe shift or a beat frequency if the equipment is in uniform translational motion. The special theory of relativity does not apply to Sagnac because Lorentz transformations are restricted to pure translation. While this saved the situation from formal contradictions, it did leave a disturbing conceptual discontinuity. Why did Galilean kinematics suffice for rotational motion and then fail for pure translation?

Why was Special Relativity theory only applicable to uniform linear relative motion, while Newtonian theory could only explain rotational motion? The scope of each theory was exclusive of the other; neither could describe all types of motion.

Claims and Responses:

Claim #1: The Sagnac instrument has no connection with its environment; light speed is independent of the device's surroundings.

Response: The device is a closed reference frame, which however detects its own turning motion, indicating a connection with the

environment. This contradiction means that the implication of postulate 2 of Special Relativity theory is incorrect - space is not empty.

Claim #2: Ballistic theories such as Ritz's were tested directly, as the light paths around the ring had different lengths to travel. The detector and mirrors would be moving toward/away from the light. In a ballistic theory, a light photon has particle properties, so its speed depends on the motion of the source, $c \pm v$. Like a bullet fired from a moving gun, the speed of light is combined with the motion of the source, as in Galilean relativity. Ballistic theories predict no shift, that is, the net velocity between the light source and detector was zero, since they were both fixed on the rotating platform. However in the Sagnac experiment a fringe shift effect *was* seen, eliminating any simple ballistic theory.

Response: The reasoning is correct but ignores the extinction effect of the stationary air through which the light passes. Application of ballistic theory to the absorption of the photons by air molecules at rest (on average) leads to an emission of a new photon at $c + 0 = c$. Although the light is emitted from the mirrors at $c \pm v$, the beam speed is converted to the free space value of c when passing through air. Its measurement would then agree macroscopically with Special Relativity theory – the observed speed would always be c . An obvious test of the extinction hypothesis is to employ a vacuum Sagnac interferometer or perform the experiment in space.

Claim #3: In an inertial frame of reference, mirror motion during light flight causes the opposite moving waves to be reflected at different places, leading to a net path difference.

Response: Replace all the individual mirrors by one cylindrical mirror. This is equivalent to considering an N-sided polygon in the limit as $N \rightarrow$ infinity, so the light path is everywhere tangent to the cylindrical mirror. There is now no need for the mirror to rotate at all – opposite moving waves will not be reflected at different positions in space.

Claim #4: The ether cannot rotate around the Earth.

Response: See response above.

Claim #5: But the rotating ring is accelerated circular motion, while c is constant only in inertial frames of reference.

Response: Herbert Ives showed by analysis in 1938 that “the Sagnac experiment in its essentials involves no consideration of rotation,” meaning that it is not the rotation that produces the effect. The measured Sagnac effect would be unchanged if the Sagnac interferometer were

moved along a chord of a hexagon-shaped light path rather than rotating the entire structure. The effect could thus be produced without rotation or acceleration, confirming that there are linear versions of the Sagnac effect. Operational Global Positioning System technology uses the Sagnac effect to synchronize clocks that may be in any arbitrary state of motion.

Claim #6: The Sagnac effect is independent of the choice of reference frame. An observer co-moving with the ring will find the speed of light tangent to the ring is: $c \pm r \omega$ for light moving against or with the rotation of the ring. Only the case of $\omega = 0$ is inertial. For $\omega \neq 0$ this frame of reference is non-inertial, where Special Relativity theory does not apply, so the speed of light in this case can vary from c .

Response: This shows that rotation is not excluded in Special Relativity, and exposes the confusion of supporters.

Claim #7: Special Relativity theory does not apply to non-inertial systems, like the Sagnac device.

Response: The non-inertial character of the rotating platform is of no significance since the light travels through free space between the mirrors. The light beam is observed to move rectilinearly, not in a curved path.

Claim #8: Sagnac effect causes a Doppler shift, as predicted by Special Relativity.

Response: There is no Sagnac Doppler shift. If the observer is in the laboratory, there would be a very small second order Doppler effect when observing the moving apparatus, but this is insignificant in affecting the result. There was no Doppler effect at all in the original Sagnac test, because the observations were made aboard the spinning disc, and the observation point was at a constant distance from the point of interference.

Claim #9: Post Sagnac, Special Relativity theorists proposed that the observer being in a rotating frame (non-inertial) made Special Relativity inapplicable.

Response: At radius r the acceleration is $a = v^2/r$ and the difference in observed light speeds is $2v$. By doubling the radius the acceleration is $a = v^2/(2r)$ and the difference in observed light speeds is still $2v$. The speed difference is completely independent of the acceleration. Even when $a = 0$, the frame thus being inertial, the difference is still $2v$. Sagnac's

original assessment was correct – the speed of light is dependent on the observer.

Claim #10: This analysis is perfectly valid in both the classical and the relativistic contexts with respect to the axis-centered inertial frame.

Response: The classical result is:

$$\Delta t = 4A\omega/c^2 = 4\pi r v/c^2$$

and Special Relativity theory is:

$$\Delta t = 4A\omega/(c^2 - v^2) = 4\pi r v/(c^2 - v^2)$$

At the non-relativistic speeds used by Sagnac, the second order difference between the two would not be detectable. But there is a theoretical difference.

Claim #11: A clock attached to the perimeter of the ring would record a lesser time, by the factor $\gamma = (1 - (v/c)^2)^{1/2}$, so the Sagnac delay would be $[4A\omega/c^2]/(1 - (v/c)^2)^{1/2}$. However, the characteristic frequency of a given light source co-moving with this clock would be greater than the axis-centered frame by precisely the same factor, so the actual phase difference of the beams arriving at the receiver is invariant.

Response: One relativist says the perimeter is non-inertial and Special Relativity theory can't be applied. Another relativist says Special Relativity theory and Lorentz transformations can be applied and produce the observed effect. The inherent confusion of Special Relativity theory's principles and application surfaces again.

Claim #12: The Sagnac effect rules out the ballistic theory of light propagation (as advocated by Ritz in 1909), according to which the speed of light is the vector sum of the velocity of the source plus/minus a vector of magnitude c .

Response: In ballistic theory/Galilean relativity, the light traveling against the rotation is detected as:

$$(1) c_1 = c + v$$

where v is the velocity of the rim. The light traveling with the rotation is detected as:

$$(2) c_2 = c - v$$

In Special Relativity theory, light speed is independent of the observer, so the trivial results of the Sagnac experiment should be:

$$(3) c_1 = c_2 = c$$

The Sagnac experiment confirmed that (1) and (2) were, in fact, correct, supporting the classical concepts of an absolute rest frame, as Sagnac claimed.

Claim #13: Both the Michelson-Morley experiment and Sagnac are consistent with Special Relativity, since Sagnac found that, in ambient space, the light is propagated with a constant speed, independent of the overall movement of the source of light and optical system.

Response: No. Sagnac found that the light speed observed was affected by the motion of the disc.

Claim #14: The Sagnac effect is a purely “classical” effect. Relativistic effects apply equally in both directions, hence, the higher-order corrections of special relativity cancel out of the phase difference.

Response: This Special Relativity theory commentator says the Classical and Special Relativity theory formula for the time delta are the same, while others say Special Relativity theory has a $1/(c^2 - v^2)$ correction to the classical value. How can these subjective interpretations be considered as objective evidence of a well-understood theory of nature?

Claim #15: The Sagnac effect is based on isotropic light speed with respect to one particular system of inertial coordinates, the axial frame. All other inertial coordinate systems, like the observer on the ring, are related to this one by Lorentz transformations, which are defined as the transformations that preserve light speed. Hence no description of a Sagnac device in terms of any system of inertial coordinates can possibly entail non-isotropic light speed, nor can any such description yield physically observable results different from these.

Response: If the reference frames are reversed and the disc circumference frame is the observer’s frame, and the Lorentz transformations give the corresponding distance and time measurements for the axial frame, then why don’t the predictions for this model match the Sagnac measurements? The reason is that the axial frame in the laboratory is the preferred Geocentrism frame – the circular motion is not.

Claim #16: The pulses of light are never (let alone always) at the same point in the loop at the same time during their respective trips around the loop in opposite directions.

Response: The pulses traveling in opposite directions must overlap or cross once before completing one circuit.

Claim #17: At any given instant the point of the loop where one pulse is located is necessarily accelerating with respect to the instantaneous inertial rest frame of the point on the loop where the other pulse is located (and vice versa). Only one inertial reference frame can exist on the loop; all the rest are non-inertial.

Response: Circular path implies non-inertial; straight line implies inertial? Circular motion at uniform speed as an inertial reference frame has been questioned when centrifugal force and acceleration are considered. For uniform circular motion there is no component of acceleration parallel to the path in this case; otherwise the speed would change. Tests with various mirrors forming different polygons on a rotating table confirm that the light traveling in a straight line on a polygonal section does not travel at the speed c relative to the moving disc. Even Einstein said there is no reason to believe that light traveling in a series of polygonal lines will behave differently from light traveling in one straight line. Many supporters claim that Special Relativity theory cannot be applied to motion in a circle, or on a closed circuit, or to anything but single straight line motion. But Einstein applied Special Relativity theory to exactly those situations in the 1905 basic paper. Einstein (1916) later changed his mind when he launched his General Relativity:

The word 'special' is meant to intimate that the principle is restricted to the case when K' has a motion of uniform translation relatively to K , but that the equivalence of K' to K does not extend to the case of non-uniform motion of K' relatively to K .

Note well, this is just one example of Einstein's many vacillations that allow relativity defenders to selectively cite Einstein's writings whenever there is a seemingly insurmountable difficulty with Special Relativity.

Claim #18: The two pulses do *not* traverse similar paths from emission to detector (assuming the device is absolutely rotating). The co-rotating beam is traveling slightly farther than the counter-rotating beam *in the inertial sense*, because the detector is moving away from the former and toward the latter while they are in transit.

Response: Introduction of undefined terms is a common ploy in Special Relativity theory explanations. What does “in the inertial sense” mean? If one beam travels farther than the other this means it travels faster. Why is the motion of the detector a problem?

Claim #19: The second-order effects of Special Relativity theory have been confirmed empirically by the Michelson-Morley experiment. Considering the Earth as a particle on a large Sagnac device as it orbits around the Sun, the ether drift experiments demonstrate these second-order effects, confirming that the speed of light is indeed invariant with respect to relatively moving systems of inertial coordinates.

Response: Second order effects were not originally thought to be detected by the Michelson-Morley experiment – the null result. This was Einstein’s rationale for proposing Special Relativity theory with an etherless medium for light. Later experiments by Miller and re-analysis of the Michelson-Morley experiment’s raw data show a drift velocity of ~ 8 km/s was present, contrary to the postulates of Special Relativity theory. It is a contradiction to say that the ether drift shows the validity of Special Relativity when, in fact, it was based on an etherless space.

Claim #20: In the Sagnac experiment the path around the circumference should be unwrapped into a straight-line path and the Lorentz transformation from the stationary to moving frame applied to this unwrapped moving circumference. This gives the correct fringe shift.

Response: Yes, but it directly contradicts the Goldstein and Misner, Thorne and Wheeler theory prescription for handling accelerations within Special Relativity theory as a succession of infinitesimal Lorentz transforms

Claim #21: No matter how large the disc, it does not approximate a straight line, because there is still some rotation involved. So no part of the Earth qualifies strictly as an inertial frame of reference.

Response: The center of the Earth, presumed to be moving around the Sun but not rotating (the ECI frame – Earth Centered Inertial) is taken as a suitable and perfectly acceptable inertial frame for Global Positioning System measurements, with no operational problems noted. The Hefele & Keating (1972) experiment also claimed that nearby space, co-moving with the Earth, was acceptable as a suitable inertial frame. This is equivalent to the Geocentric frame as far as Earth’s movement is concerned. The non-rotating Earth-centered frame is acceptable to Special Relativity theory adherents as a satisfactory inertial frame of reference. But the surface of the earth (the laboratory) is not considered as an inertial frame for the Bilger laser test, even though there is no

relative motion between observer and the ring laser apparatus, and the center of the Earth rotates, during the Hafele & Keating case, by an angle greater by 10,000,000,000,000 than the Bilger test. In the Bilger test there is a rotation that is 5×10^6 smaller than the Global Positioning System case. In the original Sagnac test, the Earth would have turned 2.8×10^{-13} orbital degrees during the test. During a Global Positioning System test around the equator, the Earth would have turned by 10,000,000 times the amount it turned during a Sagnac test. Asserting that Special Relativity theory does not apply to rotation, while simultaneously using it daily in operations such as the Global Positioning System that has seven orders of magnitude greater rotation than the Sagnac experiment, is illogical, and a very narrow and ‘just so’ manipulation of the meaning of an inertial frame.

The results are the same for spinning discs of any radius; with a disc of arbitrarily large radius, the path shape approximates a straight line. The effect thus applies to all objects moving at constant speed. If the disc is so large that we cannot distinguish, within experimental error, any deviation from a straight line, then the result is applicable to straight-line motion. The deviation from a straight line on a distance such as used in the Michelson/Gale (600m) tests will not be detectable. As the Earth is said to perform all sorts of movements with respect to Sun, galaxy and stars, then technically speaking, Special Relativity theory cannot be applied anywhere on Earth.

Claim #22: The Sagnac device centers around one particular system of inertial coordinates (center of a circle), and all other inertial coordinate systems are related to it by Lorentz transformations.

Response: What happens to the measuring clock when the radius of the circle becomes very large and the clock’s velocity small – a limit process? The Sagnac effect still applies and the clock’s motion becomes more linear. In this limit process, it is reasonable to treat the moving clock as an inertial reference frame in its own right. Contrary to the constancy of c in Special Relativity, the Sagnac effect requires that the speed of light must be either $c + v$ or $c - v$, and not c ! This limit process shows that Special Relativity theory contradicts itself, as the real measurements are made in the moving clock frame and not at the center of the disc. If only an inertial frame of reference at the circle’s center can explain the Sagnac effect, then Special Relativity theory is really Special Absolutivity Theory.

Summary:

1. Sagnac modified the Michelson-Morley apparatus to look for the rotation of the Earth within the ether.
2. The light beams are in synchronism when released.

3. The light beams are not in synchronism when they have completed one turn of the apparatus.
4. Any observer on the rotating apparatus, or stationary in the laboratory, will observe identical fringe shifts.
5. The light behaves as if traveling at constant speed relative to the laboratory Geocentric system, oblivious to the spinning table around it. The light does not travel at a constant speed c relative to the observer aboard the spinning table. Moving in the same direction as rotation, it goes slower than c ; in the other direction it goes faster than c .
6. Time and distance aboard a spinning disc are identical with time and distance in the stationary laboratory. They are also identical aboard an object that is moving at uniform velocity in a straight line.
7. The Sagnac effect applies to uniform straight-line motion, just as it does to rotational motion.
8. The Sagnac effect is the result of a non-isotropic speed of light that arises any time an observer moves with respect to the Geocentric frame.
9. The Sagnac results are compatible with a constant velocity of light moving through ether in an absolute frame of reference.
10. The Sagnac equation applies for any shape of circuit.
11. The Sagnac experiment was sufficient proof of spatial anisotropy ($c \neq \text{constant}$) and indirect evidence for the classical Galilean law of velocity addition.
12. Ring laser experiments confirm that light, in small-scale experiments, travels relative to the laboratory – the Geocentric Earth frame.
13. Since the rotation speeds are not relativistic, both classical physics and special relativity can be applied.
14. Special Relativity theory clearly disagrees with the Sagnac results. Sagnac effects are dependent on the velocity relative to the Geocentric frame rather than on the velocity of the receiver relative to the source, as Special Relativity theory predicted.

15. The Sagnac effect is the electromagnetic counterpart of mechanical rotation. A free gyroscope can be used to measure the rotation of the gimbal mounting; a Sagnac interferometer measures its angular velocity with respect to the local inertial (Geocentric) frame.
16. By Mach's principle the Sagnac effect cannot distinguish between whether the Earth actually rotates and the ether is at rest, or the Earth is at rest and the ether whirls around it.
17. The photographic record could be taken from the spinning disc or from the fixed laboratory - the result is the same.
18. Sagnac found a velocity of 13 m/sec caused one fringe shift (one cycle difference in the beam), a speed far below consideration of Special Relativity theory effects.
19. Wang *et al.*, (2003) showed that the Sagnac result is also obtained on a two way linear path, by reversing a light beam sent out on a straight line on a moving platform and measuring the difference in return time.
20. The second order effect forecasted by Special Relativity, for the time dilation aboard a moving object, is far smaller than the first order effect observed in the Sagnac test.
21. The original Sagnac experimental results were not specifically due to rotation. Wang has constructed a Fiber Optic Conveyer experiment that directly verifies that linear motion has the same effect as circular motion, consistent with Geocentric theory.
22. Variations include:
 - a. putting the apparatus in a vacuum,
 - b. using some other medium than air,
 - c. rotating the medium while the mirrors are stationary in the Earth frame of reference,
 - d. keeping light source and detector fixed in the Earth frame, separate from the rotating platform,
 - e. moving the rotation center away from the geometric center,
 - f. changing the shape of the circuit but not the area.

None of these modifications influenced the result.

Geocentrism interpretation:

The Sagnac effect shows that the light is not affected by the movement of the source, and that light travels relative to the laboratory, because assuming that the light travels relative to the laboratory gives the correct result in all cases. The laboratory frame is the Geocentric frame. In the case of circular trajectories, Sagnac has shown how the velocity of light varies linearly with the observer's velocity. The absolute velocity of light, c , with respect to a fixed earth frame (Geocentrism) is an experimental fact. The results are compatible with all known experiments.

There is an inconsistency, however, in the relativistic *interpretation* of what's really happening locally in the Sagnac device. In Special Relativity theory, each point on the perimeter of a rotating circular Sagnac device is always instantaneously at rest in *some* inertial coordinate system, and according to Special Relativity the speed of light is precisely c in all directions with respect to any inertial system of coordinates. Thus the speed of light must be isotropic at every point around the entire circumference of the loop, and hence the light pulses must take an equal amount of time to traverse the loop in either direction. The beams of light are traveling the same inertial paths through space as they proceed from the source to the detector, whether the mirror platform rotates or not. Yet their time difference is only zero if the platform is not rotating with respect to the Earth – the Geocentric frame. The inanimate unintelligent Sagnac device knows that it is rotating with respect to a special/preferred/absolute frame of reference – so, why don't the scientists observing the apparatus also know it?

The dependence of the Sagnac effect on the enclosed Surface relative to the rotation axis recalls the familiar classical electric and magnetic fluxes which are key concepts in Maxwell's laws, $\mathbf{E} \cdot \mathbf{S}$ and $\mathbf{B} \cdot \mathbf{S}$. The question now is, what field is flowing through the Sagnac ring area to produce the fringe shift anisotropy? Sagnac results are an uncontested fact, but the interpretation is far from that. Special Relativity advocates use an implicit assumption of a universal frame of reference for convenience, but boldly deny its existence when questioned if its use is arbitrary or mandatory.

What is the logical approach? When the Sagnac turntable is at rest, all agree there is no fringe shift. If c is, indeed, constant in all inertial reference frames in Special Relativity, will spinning the whole room, including the light source and detector, around the stationary platform of mirrors change the arrival time of the two beams? Special Relativity theory says: "of course not!" The Sagnac effect says: "yes – if the room was stationary in the lab/Geocentric frame!"

Sagnac developed his equation based on the assumption that an ether existed. Kelly showed that the same result is found using the stationary laboratory. Yet he (and others, like Cahill and Hatch) fail to

put the two ideas together into the logical conclusion that, if the universal frame provided by the ether is also supplied by the laboratory (Geocentric) frame, then the universal absolute reference frame is the stationary Earth!

Although there is no universal frame of reference and more than two frames of reference are never theoretically needed, the Sagnac explanation for Special Relativity theory must add a third frame of reference called “proper time.” In the third frame, the light beam is traveling a different distance, which is then asserted as the reason the two beams are unsynchronized. But why is there a proper time? Why is not the frame of the emitter or source, or the axis of rotation, capable of giving the “proper” results? The choice isn’t convenient or expedient – it’s mandatory, and thus absolute! In actuality, most attempts to explain the Sagnac effect consistent with Special Relativity implicitly assume ether’s existence, under the guise of a third reference frame or a “proper time.”

The Michelson-Morley experimental apparatus designed to detect the relative motion of the Earth and the luminiferous ether has a fundamental flaw that is exposed by the Sagnac effect: the effect of the relative motion does not depend on the length of the optical path, but on the surface enclosed by the optical path, as shown originally by Michelson in 1904 and confirmed by Sagnac in 1913. If the speed of light is a constant for the observer, then, for the observer on the rotating ring, light should take the same time to travel each way and no effect should occur. Sagnac proved that there *is* ether that the light has to pass through, a formidable challenge to Einstein’s theory of Relativity that claims there is no need for ether. It is for this reason that the Sagnac experiment is virtually ignored by modern scientists.

Michelson-Gale:

Michelson and Gale showed in 1925 that the Sagnac effect can also be seen if the apparatus is fixed to the Earth, making the Sagnac platform the same dynamically as the Earth itself – the same reference frame of the Michelson-Morley experiment. Unlike the Michelson-Morley experiment, the Michelson-Gale experiment did not produce null results. The observed displacement was closely related to the rotational velocity of the Earth, lending support to ether theories.

Like the Michelson-Morley experiment, Michelson-Gale compared the light from a single source after traveling in two directions over two rectangles of different size. Light in the rectangles reflected off corner mirrors and returned to the starting position. The light exiting the two rectangles was compared on a screen. Michelson-Gale utilized a large rectangular array of pipes and mirrors, with the East-West legs about 7 football fields long and the North-South legs about 4 fields long. This large area would make the equipment sensitive to the Earth's rotation. A calibration loop had the same North-South length, but a very short length in the East-West direction of the Earth's rotation, for comparison of the fringe shifts in the full-size loop.

If ether is dragged rotationally by the Earth, light traveling in the longer rectangle will encounter a different amount of drift than in the smaller one, because the two legs of the longer rectangle are spinning at different speeds, the northern leg moving slower than the southern one.

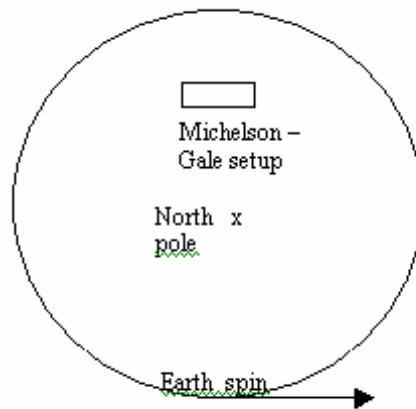

Numerical results can be easily derived by realizing that the equipment is equivalent to the Sagnac experiment, except that the mirror platform is fixed on the Earth, so any rotation detected must be due to the Earth itself. The Sagnac time difference is:

$$\Delta t = 4A\omega/c^2$$

in which the rotation axis is always orthogonal to the mirror platform. As the diagram above shows, the Earth's axis of rotation projects onto the loop of the Michelson-Gale apparatus on the Earth's surface at an angle corresponding to the latitude ϕ . At the equator ϕ is zero and the polar axis is parallel to the Michelson-Gale loop area; there is no delta t for this location. At either pole ϕ is $\pm 90^\circ$, and the polar axis is perpendicular to the Michelson-Gale surface. This is the maximum value possible, corresponding to the Sagnac value above. At any intermediate latitude the time difference for Michelson-Gale is given by:

$$\Delta t = 4A\omega (\sin\phi)/c^2$$

For a rigorous but equivalent derivation of the Michelson-Gale equation, see the corresponding footnote.¹³³⁷ This exact result is obtained without explicitly invoking an ether, Lorentz transformations or General Relativity.

Claims and Responses:

Claim #1: The Michelson-Gale experiment shows that the Earth is rotating with respect to the heavens.

Response:

1. It is only the relative rotation between Earth and cosmos that was detected, hence the Machian universe cannot be excluded.
2. The precision of the experiment could not distinguish a 24-hour solar period (a local effect) from a period 4 minutes shorter (the universal sidereal period).
3. Just as the free mechanical motion of the Foucault pendulum defined a plane of motion relative to the rotating heavens, the free motion of the Michelson-Gale light ring defined a plane of radiation relative to the same heavens.

Claim #2: The experiment was expected to generate a positive result both for entrained ether as well as that due to relativistic effects. The Michelson-Gale result appeared to be a null result, or at least a rather inconclusive one. The average of 269 measurements showed .26 fringes, which is minimal evidence of rotation and the ether, but also not statistically significant.

Response: Detailed analysis of the data clearly shows the periodic nature of the 24-hour effect. Of course, averaging the wave greatly reduces its magnitude. The largest fringe was 0.55. Modern equipment, such as the optical gyroscope, has erased any doubt of its reality!

¹³³⁷ http://www.commonssensescience.org/pdf/pdf/light-speed_and_aether.pdf

Claim #3: It was not considered a failure of Einstein's relativity because the rotating Earth is not considered to be an inertial frame of reference. Special relativity does not apply here. General relativity must be used since Special Relativity theory considers this a Sagnac-type of experiment in a rotating (non-inertial) frame of reference.

Response: See the Sagnac experiment responses to the same claim made then, that the environment is non-inertial.

Summary:

Michelson-Gale detected the ether moving past the Earth's surface at 2% of the rotation speed. While the Michelson-Morley experiment detected no heliocentric movement, the Michelson-Gale experiment measured either the effect of the Earth's rotation or the ether's rotation around the Earth. As with the Sagnac test, Michelson-Gale data show clearly that c is not a universal constant, contradicting Special Relativity.

The assumption of ether needed ever more corrections to explain new and improved experiments. Finally, Einstein eliminated the ether. The derivation above demonstrates that no corrections are necessary. By means of bad assumptions, faulty interpretations and frequent back-tracking, Einstein formulated the Special Theory of Relativity. Creative interpretation of Special Relativity is needed by individuals to apply it to the experiments covered so far, an instability that can be traced to its erroneous underlying principles. Proponents insist on patching up the application of Special Relativity to reality, trying to rescue a doomed theory, rather than examine if the foundation is at fault.

The Hafele-Keating Experiment:

Hafele-Keating press release:

During October 1971, four cesium atomic beam clocks were flown on commercial jet flights around the world twice, once eastward and once westward, to test Einstein's theory of relativity. From the actual flight paths, theory predicted that the flying clocks, compared with reference clocks at the U.S. Naval Observatory, should have lost 40 ± 23 nanoseconds eastbound and gained 275 ± 21 nanoseconds westbound.... Relative to the atomic time scale of the U.S. Naval Observatory, the flying clocks lost 59 ± 10 nanoseconds eastbound and gained 273 ± 7 nanosecond westbound... These results provide an unambiguous empirical resolution of the famous clock "paradox" with macroscopic clocks.

According to Special Relativity, the aircraft moving eastward with the Earth rotation would have more delay than the one moving westward. Compared to the universe, the eastbound aircraft has a slight boost in speed over the westbound, with the observatory clock halfway between the two. For flights eastbound, v has a positive sign (same direction as Earth rotation) so the net shift in time will be negative (aging more slowly). Westbound, the time shift is positive (aging faster).

Gravity Time Shifts:

For small changes in the gravitational potential, the reading of the surface clock, T_E , compared to the central standard clock at the Earth's center, T_0 , is approximately:

$$T_E \sim T_0(1 + gR/c^2) \quad (1)$$

Referred to the same clock, the airplane clock reading at height h is:

$$T = T_0[1 + g(R + h)/c^2]$$

The difference between the two is:

$$T - T_E = T_0(gh/c^2) \quad (2)$$

From (1):

$$T_0 = T_E(1 + gR/c^2)^{-1} \sim T_E(1 - gR/c^2)$$

To order $1/c^2$ (2) becomes:

$$T - T_E = T_0(gh/c^2) \sim T_E(1 - gR/c^2)gh/c^2 = T_E(1 - gR/c^2)gh/c^2 \sim T_E(gh/c^2)$$

comparing a surface clock(T_E) and the plane above the surface (T).

These predict a time difference of 144 nanoseconds eastbound around the world for a flight time of 41.2 hours at 8900 meters. The time shift is positive (aging faster) for both east and westbound flights. The predicted value of 179 ns for the westbound flight of 48.6 hours uses $h = 9400$ meters.

Velocity Time Shifts:

The time dilation expression

$$T = T_0/(1 - v^2/c^2)^{1/2}$$

T_0 is the rest frame “proper time” for the event. For small velocities, T is about:

$$T = T_0(1 + v^2/2c^2)$$

The problem with measuring the difference between surface and aircraft clocks is that neither location is exactly an inertial frame. If we take the center of the earth as an approximation to an inertial frame, (the ECI or Geocentric frame), then a “proper time” can be measured at the center as if the master clock were there. Time measured by a surface clock would be larger than the proper time:

$$T_S = T_0 [1 + R^2\omega^2/2c^2] \quad (3)$$

R is the radius of Earth and ω is its angular rotation. The airplane clock would be approximately:

$$T_A = T_0 [1 + (R\omega + v)^2/2c^2]$$

since $h \ll R$. The difference in the times compared to the hypothetical master clock would then be:

$$T_A - T_S = T_0[(2R\omega v + v^2)/2c^2]$$

In the experiment the master clock is on the moving surface, not at the center, where it would be immeasurable. Solving for T_0 in (3) gives:

$$T_0 = T_S [1 + R^2\omega^2/2c^2]^{-1} \sim T_S [1 - R^2\omega^2/2c^2]$$

and then substituting for T_S in the last equation:

$$T_A - T_s = T_s [1 - R^2\omega^2/2c^2][(2R\omega v + v^2)/2c^2]$$

Ignoring the fourth order term in c compared to the second order, and including the lag of the plane clock behind the surface clock, the change of the airplane clock with respect to the ground clock is:

$$T_A - T_s = -T_s[(2R\omega v + v^2)/2c^2]$$

The absolute reference at the center has disappeared, to be replaced by the approximate surface time. Now the times are accessible to measurement. Both gravitational and kinematic time dilation are significant and of comparable magnitude. Hafele-Keating predictions distinguish between the gravitational and kinematic effects, but the aircraft flight data always includes both effects together.

Summary of predictions and results:

Predicted:	Time Δ in ns	
	Eastbound	Westbound
Gravitational	144 +/- 14	179 +/- 18
Kinematic	-184 +/- 18	96 +/- 10
Net effect	-40 +/- 23	275 +/- 21
Observed:	-59 +/- 10	273 +/- 21

Hafele and Keating are credited with confirming time dilation with an accuracy of about 10%, as well as answering the twin paradox. They are said to have proved that a plane's speed and direction affect the real time changes recorded by atomic clocks on the planes. There is no reason given why Special Relativity predictions only work if the Earth's axis is chosen as its reference frame, or why a real permanent change occurs in the final readings of the atomic clocks after returning to rest on the ground.

Technical problems:

An engineer, A.G. Kelly, obtained the original 1971 test report from the United States Naval Observatory and discovered that:

- The original data actually did not support the result computed in the 1972 paper.
- The Cesium clocks that were carried varied in time so badly that some of them could vary more than the total supposed results during the time of the test.

- The most stable of the four clocks indicated zero time accumulation/dilation.
- The final published outcome had to be averaged in an extremely convoluted and biased way.
- Even the inventor of the atomic clock, Louis Essen, concluded that the alterations in drift-rates of the clocks made the results useless.
- The accuracy of the clocks would need to be two orders of magnitude better to give confidence in the results.
- The actual test data were not published originally.
- The corrections made by Hefele-Keating to the raw data are unjustified.
- Hefele-Keating took the average of the drift rates before and after a flight to be the drift rate during the flight.
- The Cesium clocks drifted from 2 to 9 ns. per hour, and the rates could vary by as much as 4ns. A maximum possible error of 300 ns in the test overwhelms an expected result of only 40 ns. Note: Atomic clock systems (including Global Positioning System) are now accurate to about 10 ns, at best.
- The clocks were not of equal stability; averaging could not make the test more reliable.
- Under the revised USNO guidelines issued the following year, the Hefele-Keating results would have been rejected as unreliable.
- Although the data graphs are never linear, Hefele-Keating assume that the curves are linear for the moving planes. Non-linear when measured, they magically become linear when not directly measured!
- Time changes of individual clocks are both + and - for both flights.
- Only the linear analysis of the average clock times agrees with Special Relativity.
- Objective analysis shows no significant difference in the moving clock behavior.

Domina Spencer also analyzed the raw data from Hefele-Keating experiment and found rampant technical errors:¹³³⁸

- No two “real” cesium beam clocks keep precisely the same time.
- There are systematic rate (or frequency) differences as large as 1 second per day.
- The smooth curves interpolated during flight appear to be entirely unaffected by the plane’s motion.

¹³³⁸ <http://www.physical-congress.spb.ru/english/spenser1/spencer1.asp>

- Data have been subjected to a major smoothing process.
- No data was taken during the east or west bound trips, only before and after.

She interpreted the data to show:

- An entirely different interpretation of the experimental data from Hefele-Keating, which supports the Geocentric paradigm.
- The validity of Universal Time Postulate III: In a coordinate system that is not moving with respect to the source and which is not in rotation, the velocity of light in free space is a constant c . The Geocentric frame does not move with respect to the surface nor does it rotate.
- The distance between source and receiver is not consistent with the protocol of Special Relativity, which measures distances by equating the space-time interval between source and receiver. This challenges the Minkowski application to Special Relativity.
- Rather than Special Relativity theory Spencer uses the distance from the source to receiver, BOTH measured at the instant t of reception.
- The spherical wavefront center is always at the source (even if the source is accelerated).
- There is no time dilation.
- For a source with instantaneous velocity v , the velocity of light is not a constant c but is $c + v$. The Hefele-Keating data supports Galilean relativity, not Special Relativity.
- Only in a coordinate system in which the source is stationary is the velocity of light equal to c .

Claims and Responses:

Claim #1: The determination of time dilation is done in the rest reference frame and not by observers in any inertial reference frame measuring objects/events in another inertial reference frame. Using this single rest frame, Lorentzian transformation disagreements with time and length measurements by observers in different inertial reference frames are eliminated.

Response: Since the single rest frame, the extended Earth axis, is the only absolute reference frame in which Special Relativity theory formulas predict the time changes correctly, this absolute reference frame must be very significant to cause the frequency of the Cesium clocks, thousand of kilometers away, to modify their frequency in response to the direction and speed of the jets carrying them, in preference to all other reference frames. Because the rest reference frame is part of the methodology of Special Relativity, it must logically be a

partial cause of actual time changes in these remote atomic clocks. But is it logical that a far distant imaginary axis be a cause of actual frequency changes in atomic clocks, that is, without an intermediate medium to transmit the cause to the effect, namely, the ether?

Claim #2: The Hafele-Keating experiment indicated by means of one clock, #447, that accelerated clocks, moving between events by different spacetime paths, do not accumulate any net time difference when they are brought together again. If dependable, this says the proper times in all reference frames accumulate at the same rate, independently of spacetime paths, and thus support a view that the Special Relativity theory ‘proper time’ is a universal time rate that is the same for all reference frames.

Response: First of all, if this one clock confirms the conclusion, the other three disprove it. Second, the proper time system used by Hafele-Keating was an unacknowledged absolute Geocentric frame that will predict the observed time differences with other reference frames. This confirms Geocentrism, not Special Relativity.

Claim #3: Hafele-Keating confirmed Special Relativity theory time dilation for both clocks. The accelerated airborne clocks read uniformly less than the non-accelerated Earth-bound clocks readings, an indication that time had been dilated, and a confirmation of relativity, which predicted time dilation for accelerated/decelerated clocks.

Response: Eastbound clocks incurred time dilation – ticking slower than the ground clock, said to confirm Special Relativity. Westbound clocks incurred time contraction – ticking faster than the ground clock, also said to confirm Special Relativity. But dilation/expansion is not the same as contraction/shrinking!

Claim #4: Special relativity predicts the time difference found by Hafele-Keating when the flying clocks returning to the start.

Response: Hafele-Keating said:

...consider a view of the (rotating) earth as it would be perceived by *an inertial observer looking down on the North Pole from a great distance*. A clock that is stationary on the surface at the equator has a speed $R\Omega$ *relative to nonrotating space*, and hence runs slow relative to *hypothetical co-ordinate clocks of this space* in the ratio...

Note that the timing in the Hafele-Keating experiment was *not* done by “an inertial observer looking down on the North Pole from a great distance”; it was at the U.S. Naval Observatory, which is on the

ground, near and spinning with the equator. In Einstein's Special Relativity, where there is no preferred inertial system, relative to *this remote axial clock* the speed of both flying clocks would be *equal*, and the time dilation as well. But the eastbound clocks lost time and westbound gained time. So we have another clash between observation and Special Relativity.

Claim #5: Hefele and Keating concluded that these results provide an unambiguous empirical resolution of the famous clock 'paradox' with macroscopic clocks.

Response: Others say the results highlighted the paradox vividly, rather than resolving it. The original twin paradox was independent of path. The Hefele-Keating experiment result puts the focus on the amount of East/West motion. Consequently, aging now depends not just on $|v|$ but also the direction relative to longitude and the change in altitude, that is, path dependence, not just the endpoints. One twin *is* older than other, by the Hefele-Keating experiment. A much bigger paradox – an outright contradiction, in fact – is how this asymmetric result can be explained within either Special Relativity or General Relativity, or any other relativity theory. How can an absolute frame of reference be absolutely needed in a paradigm that says all motion is relative? How can Special Relativity theory become Special Absolutivity Theory, without anyone noticing or acknowledging the illogic?

Claim #6: If a moving clock is brought back to its starting position it should show a difference in the time registered compared to a stationary observer.

Response: No one supporting Special Relativity theory said this before the Hefele-Keating experiment. A few who are immune to logic said so afterwards. A permanent difference in the clocks violates the whole concept of Relativity. The Lorentz transforms would not be reversible if a change in view is made from the ground to the plane and then back again. There has to be something different about the traveling clock that makes it 'tick' more slowly. That difference is its motion through the ether seen from the absolute Geocentric frame.

Claim #7: The traveling clock has to first accelerate to reach a certain speed, and it is this acceleration that 'causes' the slowing down of the traveling clock.

Response: This is one of many excuses put forth by Special Relativity to escape the Hefele-Keating results, that is, one denies that Special Relativity is applicable to the Hefele-Keating experiment. Later tests show the total time difference observed is dependent on how long the

clock moves at constant speed and not on how that speed was reached – the acceleration. If two clocks receive the same acceleration and reach the same velocity, but one travels at that constant velocity for much longer than the other, the two clocks show different times relative to the ground clock. If the time difference was due to acceleration, the Lorentz formulas should be expressed as a function of the acceleration, not the velocity. The time dilation is due to duration of velocity, not acceleration. When time dilation has no connection with the cause of motion (acceleration), the cause must be sought elsewhere – in a universal environment of space, the arena in which all events occur.

Comments:

Each atomic clock, even the surface clock, was considered to be in motion relative to the central reference frame. In the original Special Relativity theory of Einstein, the “at rest” reference frame could be taken as any of the moving objects. (Einstein died in 1955, 16 years before the Hafele-Keating experiment.) For agreement with the data, the Special Relativity theory rest clock must be at the center.

The use of an ECI reference frame located on the extended axis of the Earth was based on prior knowledge that the USNO atomic clock would not allow Special Relativity formulas to work with the raw data. It was already known that Special Relativity would only work with a remote absolute reference frame on the Earth axis, such as “a non-rotating point high above the North Pole.”

The Hafele-Keating frame chosen was a Geocentric frame, with the distance from Earth assuring that the gravitational potential would not be a factor. Hafele-Keating knew the traveling clocks would be moving non-inertially with respect to a ground clock and the ground clock would be moving non-inertially on the rotating Earth, precluding a highly accurate test for Special Relativity theory. So they switched from the ground clock to a hypothetical (and unobservable) clock located at the center of the Earth. Since the surface clock would be moving at a fairly uniform speed compared to this hypothetical central clock, the time on the central clock could be represented as a fixed offset from the ground station clock, or be absorbed in a re-definition of a second. By this transformation, it was possible to pretend that the ground clock and both plane clocks were all traveling more or less inertially with respect to the earth centered clock. This approach works, not because of the success of Special Relativity theory in this situation, but because Hafele-Keating are forced, in order to obtain correct results, to use the Geocentric system.

When physicists calculate time dilation, they neglect the Earth’s spin. According to Hafele-Keating, time differences depend entirely on the absolute rotational velocities of the airplanes. Putting aside Relativity theory, contemporary physicists *prefer* the Earth Centered Inertial frame

(Geocentrism) to make their predictions correct *in practice*. Without fanfare, discussion, or explanation, they quite deliberately ignore the reference frames of the non-rotating aircraft and the non-rotating, *non-orbiting* Sun, or even the rotating ground stations. Why? One reason – only the Geocentric worldview works. The emperor – Einstein – has no clothes.

Einstein abolished “absolute time,” considering it immeasurable and irrelevant. Physics has since advanced without any way of definitively measuring time in an acceptably objective way. Relative time is counter-intuitive to the understanding of time held by Galileo and Newton. Without this logical base, confusion arises when the common sense of time is replaced by the twisted ideas of Special Relativity. The Hafele-Keating experiment revealed that changes in time depend on absolute speed through space – the vector sum of the Earth’s rotation and airplane speeds – rather than on the relative velocities of the clocks, as in Special Relativity.

Only a few space scientists (and so virtually nobody on earth) know that the Earth’s ECI/Geocentric frame is always used for near space navigation and for local phenomena, while the solar system barycentric (SBC) frame is used for trans-planetary navigation and deep space phenomena. Even fewer know that, directly or indirectly, explicitly or implicitly, the SBC system values are transformed into the Geocentric frame to get results that agree with the predictions of Relativity. With all calculations buried out of sight in the bowels of computer programs; with the specialized and sophisticated code employed, translatable only by the initiated, this practice can be hidden (and denied), just a schoolboy can bury a fudge factor in a sea of lab report data, to get the standard “correct” result.

Despite the dubious protocol and analysis of Hafele-Keating, later experiments using atomic clocks, aircraft, satellites and rockets have proven that time slows down the faster you move. In 1975 Professor Carroll Alley tested Einstein’s theory using two synchronized atomic clocks. One clock was flown on a plane for several hours, while the other clock remained on the ground. Upon return, the clock on board the plane was found to be ever so slightly slower than the one on the ground. This was not due to experimental error, and has been repeated numerous times with the same result. This difference in time is even more pronounced today in satellites such as the space station and Global Positioning System. This is because satellites are traveling at speeds much faster and for much longer periods than possible in an airplane.

Ether drag model:

Suppose Hafele-Keating had interpreted the results using an ether that doesn’t rotate with the Earth and extends high into the atmosphere. This choice of a rest reference frame would work with the formulas and

have the correct choice of coordinate system. The ether that is dragged with the Earth's motion comes into direct contact with the atoms in all of the atomic clocks. There is thus a physical connection established between the Lorentzian formulas of Special Relativity and the ether that causes resistance to the atomic motions in the clocks. This is far more logical than the Hefe-Keating remote axial frame that offers no physical cause for its importance or necessity!

In Einstein's Special Relativity theory *any* two moving reference frames could be *directly* compared to each other. In the ether drag theory, two reference frames can only be compared to each other indirectly, by comparison of each to its ambient ether (essentially a local absolute reference frame) and then, calculating their interrelationship *via* the intermediate ether, a two step process. The meaning of ambient ether here is that it fills all space and flows, a dynamic mode, not static.

In the Hefe-Keating experiment, westbound flights fly with the ether wind causing less resistance and running faster than a stationary clock. And vice versa, for the eastbound flights. The ether theory has no problems with the clock or twin paradox and makes exactly the same predictions as the Hefe-Keating version of Relativity as to whether the clocks speed up or slow down relative to a stationary clock, and by how much. This is true because both the Hefe-Keating rest reference frame and the ether drag reference frame are the same coordinate system – the Geocentric paradigm.

With the ether drag theory, the Hefe-Keating experiment proves the existence of the ether wind. But whether it is the Earth that rotates and drags the ether with it, as stated by Michelson, cannot be determined by Hefe-Keating experiment alone. For the rotation of the Earth through this ether has the same effect as if the Earth were stationary and the ether was moving – a re-discovery of Mach's principle, keeping the Geocentrism option open. In the Geocentrism mindset the ether wind speed detected by Hefe-Keating is the same as the [alleged] rotation velocity of the earth! From an ether perspective, the Hefe-Keating experiment can only be satisfactorily resolved by assuming a universal and absolute reference frame and a medium that transmits light. (Note: there are two experiments that indicate that not only does c vary by altitude (ether density), but also that in the denser ether c is faster. Dayton Miller is one, Hefe-Keating the other).

Summary:

1. Acceleration during the trip had no effect on the results, only the height and speed of the planes.
2. As also found with Global Positioning System operations, the results were only consistent if the reference clock was in the Earth Centered Earth Fixed frame - the Geocentric frame!

3. Hafele-Keating claim the results support Special Relativity, yet the round-trip in either direction should produce no net time dilation when the clocks are returned to the reference clock and record zero relative motion! If the on-board clock were taken as a reference, then it would show the same results compared to the Earth clock, so each one would be 59 ns slower than the other. This is the unrebutted Dingle paradox of time dilation - a simplification of the famous twin paradox! If $A < B$ then $B < A$! That such illogical thoughts and defiance of reality can occur among objective scientists is incredible. So confused are the experimenters that they seem quite willing to plug numbers into an Einstein relativity formula, without ever asking if the result makes sense.

4. Not only the experimenters but all the relativity advocates accept this as a confirmation of Special Relativity!

5. These results, confirmed by Global Positioning System observations, actually show the Earth is a preferred reference frame, a surprise to all but the geocentrists! There can only be a permanent change in the time readings if there is an asymmetry, a lack of relativity, an absolute reference frame!

6. There is no doubt that a *deus ex machina mathematica* will be employed to brush this result away from challenging relativity – just as Michelson never even considered the most obvious answer to his ‘null’ result, that the Earth and the ether were not moving.

7. The success of the experiment depended on using a third reference point called “proper time.” Introduction of this extra and required reference point takes relativity out of consideration because it’s simply a euphemism for hidden ether (universal reference frame).

There is no sense in emphasizing the Hafele-Keating errata. Alley and others have confirmed the sense of the experiment by iteration. Satellites afford a better test of time dilation and synchronization of moving objects in near space.

The Hafele-Keating experiment is unique in three ways:

- Two professional experimental physicists performed the design and execution of an important test of relativity with all the care, forethought and intelligence of a high school physics lab experiment.
- Their interpretation, along with other mainstream physicists, that the results confirm Special Relativity, boldly contradicts common

sense and the simplest understanding of Special Relativity theory postulates.

- The biggest surprise is that the flubbing of the experimental protocol and the gross misinterpretation of the readings went without comment in the mainstream journals, and were noted only in the physics backwaters, as cited above.

Even more intimidating, perhaps this situation is not unique to Hafele-Keating but may be prevalent in most leading-edge science pursuits, especially where prestige and funding are at stake. This consideration is true not just for Relativity but for cosmology, geology and biology, as well.

Global Positioning System (GPS)

Claim: The Global Positioning System (GPS) is the Earth's only fully functional satellite navigation system. It is a constellation of more than two dozen satellites that broadcast precise timing signals by radio to electronic receivers, which allow them to accurately determine their location (longitude, latitude, and altitude) in real time. The GPS is a marvelous laboratory for testing Relativity theory because the orbiting and ground atomic clocks have differing gravitational potentials and high relative speeds. Their high precision confirms predicted relativistic clock corrections to less than one percent. The Global Positioning System needs universal synchronization of satellites and ground stations; the preferred reference frame is the ECI reference frame.

Response: Note the following:

- Not an experiment, but a technology whose successful daily operations support Geocentric cosmology and challenge Relativity theory dogma.
- All high precision Global Positioning System applications correct for the Sagnac effect, indicating that the speed of light is not always constant to the moving observer. The Sagnac effect in Global Positioning System operations are in conflict with Special Relativity.
- Global Positioning System computations locate moving receivers by including the $v \pm c$ Galilean model.
- ECI is the standard technical name for the Geocentric frame.

Further Details:

The Global Positioning System is a satellite-based navigation system consisting of a network of 24 orbiting satellites that are eleven thousand nautical miles in space and in six different near-circular orbital paths. The satellites are constantly moving, making two complete orbits around the Earth in just under 24 hours at about 3.6 kilometers per second. The satellite orbits are roughly 25,000 kilometers from the Earth's center, or 20,000 kilometers above the surface, far below the orbits of the geosynchronous or geostationary satellites. The orbital paths of these satellites take them between roughly 60 degrees North and 60 degrees South latitudes.

The satellites contain precise atomic clocks whose rates depend both upon satellite velocity and altitude and are stable to one part in 10^{14} over a day's time, at best accurate to about 10 ns (10^{-8} sec). An observer with a Global Positioning System receiver on the ground, in an airplane, or in a satellite, may determine his precise location by obtaining signals from several satellites simultaneously. The Global Positioning System receiver determines its current position and heading by comparing the

time signals it receives from the Global Positioning System satellites and triangulating on the known positions of each satellite.

The positions of the Global Positioning System satellites are predicted from time delay calculations that set the speed of light to a constant value, c . The U.S. Department of Defense uses radar to map the satellites to reference points on the Earth's surface; and correction data is sent back to the satellites every few seconds.

If the frame is Earth-centered but does rotate, it is non-inertial and termed ECEF: Earth-Centered, Earth-Fixed. The clock rates are not adjusted for motion relative to each other but all refer to the Earth-Centered, non-rotating Inertial frame, the ECI frame. Note diagram below:

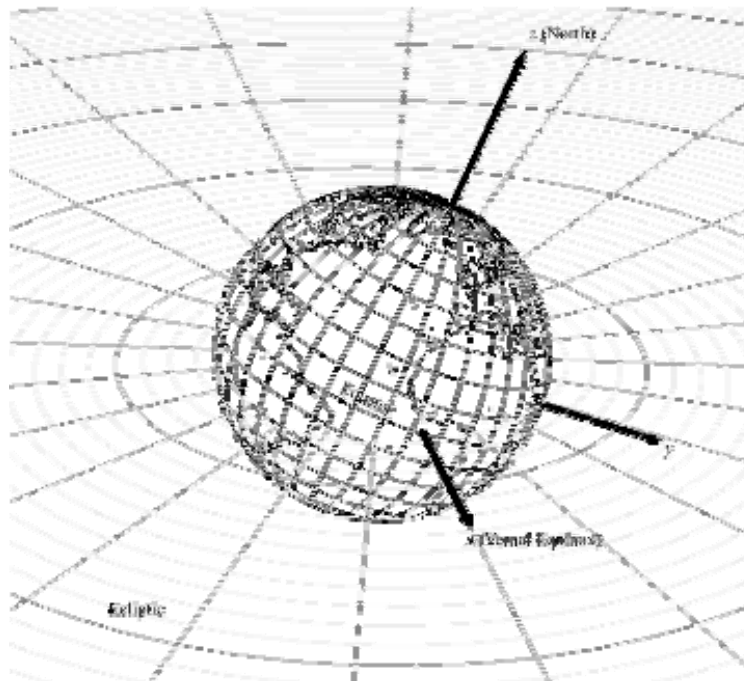

ECI frame¹³³⁹

Ephemerides are expressed in the ECEF coordinate frame, which is Earth-fixed. Global Positioning System stations broadcast the satellite ephemerides (schedule of orbit positions) in a Earth-Centered, Earth-Fixed reference frame rotating once every 24 hours. If used without removing the underlying Earth rotation, GPS would be in error, so the ephemerides are transformed to ECI using the Earth rotation rate.

Because of frame rotation, the path of a signal in the ECEF is complex. In the Global Positioning System, synchronization is performed in the ECI frame, which solves the problem of path-dependent

¹³³⁹ <http://celestrak.com/columns/v02n01/fig-1a.gif>

inconsistencies. The displacement of a receiver on the surface of the Earth due to the Earth's rotation in inertial space during the time of flight of the signal must also be taken into account. For example, the greatest distance between satellite and receiver occurs when the receiver is on the equator and the satellite is on the horizon.

Correction must also be applied by a receiver on a moving platform, such as an aircraft or another satellite, by an observer in the rotating ECEF frame. This is the Sagnac effect, the same principle employed by laser ring gyros in an inertial navigation system.

Global Positioning System clocks:

Cesium atomic clocks operate by counting hyperfine transitions of cesium atoms that occur roughly 10 billion times per second at a very stable frequency provided by nature. The precise number of such transitions was originally calibrated by astronomers and is now adopted by international agreement as the definition of one atomic second. To achieve high location precision, the ticks of the atomic clock must be known to an accuracy of 20-30 nanoseconds. Because the satellites are moving relative to and above ground observers, Relativity must be taken into account.

The Global Positioning System is based on the principle of the constancy of c in a local inertial frame: the Earth-Centered Inertial (ECI) frame. Time dilation of moving clocks is significant for clocks in the satellites as well as clocks at rest on the ground.

Special Relativity predicts that the on-board atomic clocks should fall behind ground clocks by about 7 microseconds per day because of the slower ticking rate due to the time dilation effect. General Relativity predicts that satellite clocks will seem to tick faster than the surface clocks by 45 microseconds per day. The total relativistic effect is about 38 microseconds per day. This is a huge difference compared to the required accuracy, that is, 38,000 ns as compared to 25 ns, the former being 1,500 times larger.

To compensate for the General Relativistic effect, GPS engineers slow down the satellite clock frequency at pre-launch so that when the satellites are orbiting the clocks will have the same rate as the reference atomic clocks at the Global Positioning System ground stations. A clock whose natural ticking frequency has been pre-corrected on the ground for relativity changes in orbit is a "GPS clock." A Global Positioning System clock can be used to determine local time in the surface frame at any point along the orbit. The satellite clocks are reset in rate before launch to compensate for relativistic effects by changing the international definition of the number of atomic transitions that constitute a one-second interval. With this re-definition, the clocks onboard the satellites run at nearly the same rates as ground clocks.

Global Positioning System receivers have a built-in computer chip that does the necessary relativistic calculations to find the user's location. Since the ground receivers rotate in ECEF, satellite positions change with each measurement. So the receiver must perform a different rotation for each measurement made into some common inertial frame. After solving the propagation delay equations, a final rotation must be performed into the ECEF to determine the receiver's position. This complexity – where ground and satellites are both moving – is simpler to describe in an inertial reference frame, ECI, centered at the earth's center of mass, which center is moving at constant velocity. For the solar system, an International Celestial Reference Frame (ICRF) is similarly defined, centered at the solar system barycenter.

It can be shown by sample configurations that path-dependent discrepancies in the rotating ECEF frame are inescapable by any practical means, while synchronization in the underlying ECI frame is self-consistent. For the Global Positioning System this means that synchronization of the entire system of ground-based and orbiting atomic clocks is performed in the local inertial frame, or ECI coordinate system.

Claims and Responses:

Claim #1: The choice of ECI is arbitrary; any inertial frame can be used in Special Relativity.

Response: This is quite disingenuous. Would it be used if it didn't work? Has not modern physics emphatically asserted that the ECI frame is wrong, that the Earth rotates within a sphere of stationary stars? Why is ECI the only acceptable coordinate system for successful Global Positioning System operations?

Claim #2: All laws of physics are equivalent in any inertial frame.

Response: Yet the comparison of Global Positioning System satellite signal frequencies using their relative motion differs from that obtained using the Geocentric frame, which is known to be valid experimentally. Special Relativity theory proponents claim there is no compulsion in choosing the inertial reference frame most convenient; and in the case of the GPS, this arbitrary choice just happens to be the Geocentric inertial frame. But this is not a matter of indifference, since using a satellite receiver as the observer in Special Relativity theory does not predict the observed frequency shift, but the Geocentric frame does.

Claim #3: The Global Positioning System is 1000 times more accurate than the Miller or the Michelson-Morley experiment, and it rules out any ether wind of more than 12 m/s in any direction.

Response: (1) Dayton Miller and the Michelson-Morley experiment found positive ether results – albeit the Michelson-Morley experiment interpretation was left unrecognized until recent analysis of the original data discovered the opposite sine waves pattern during day and night hours - as expected for ether wind. (2) The Sagnac effect applies to the Global Positioning System; it clearly detects a difference in light speed dependent on the Earth's rotation/ether flow.

Claim #4: Global Positioning System calculations obey the rules of Special Relativity, provided that one undoes the pre-launch clock rate corrections in the satellite clocks and use the Einstein synchronization convention (which Global Positioning System does not do).

Response: But the Global Positioning System becomes practically unusable if one uses Einstein's clock synchronization because clock corrections become time-variable, observer-dependent, and inconsistent between different clock pairs. Every clock would have its own time frame.

Claim #5: By the General Relativity principle of equivalence, a freely falling object in a gravitational field, such as a Global Positioning System satellite, can always be described in its own gravity-free Lorentzian frame. Height of the satellite is irrelevant, since the satellite is in free fall.

Response: General Relativity predicts time is slowed by decreased gravitational potential, so no Sagnac effect should be measured in the absence of gravity, but it is. Conversely, if a Geocentric frame measures an absolute flow of time, independent of local clock measurements but dependent on the clock appointed in Genesis (i.e., the motion of the lights in the firmament), then a Sagnac experiment will measure the angular rotation of the firmament (conventionally assigned to the spinning earth) as an absolute time reference. General Relativity ascribes a change in the rate clocks run to a change in the flow of time. By contrast, the Geocentrism ascribes the rate-change as a result of failing to use the absolute Geocentric frame for time measurements. In other words, one must take into account a frame that is affected by ether density and relative motion through it.

Claim #6: Relativity predicts that clocks run slower in a stronger gravitational field or when moving faster. It is found that these two effects cancel each other for clocks located at sea level. So if a clock at either pole is the standard, a clock at the equator would tick slower because of its relative speed due to Earth's spin, but faster because of its greater distance from Earth's center of mass due to the flattening of the Earth. Earth's spin rate determines its shape.

Response: The effects are the same with a rotating universe or ether, as per Mach's principle.

Claim #7: Operational data shows that the on-board atomic clock rates do, indeed, agree with ground clock rates to the extent predicted by Relativity. Therefore, we can assert with confidence that the predictions of Relativity are confirmed to high accuracy over time periods of many days.

Response: Although the magnitude of the changes are confirmed, neither the freedom of choice in reference systems nor the Sagnac effect is confirmed!

Claim #8: By the terms of Special Relativity, all inertial frames are equivalent, so the Global Positioning System is calibrated to an "ideal user" in a non-rotating, Earth-centered frame, the simple introduction of a third inertial reference frame.

Response: A new undefined concept, "the ideal user," is introduced. Where and when did Einstein speak of such an idea? The refusal to use any frame (such as the source or observer) cannot be brushed off as a trivial choice. It defies the whole philosophy behind Relativity.

Claim #9: The Global Positioning System operates by sending (coded) clock signals from orbital altitudes to the ground. This takes 80,000,000 ns from the perspective of an atomic clock. The speed of radio signals is the same from all satellites to all ground stations at all times of day and in all directions to within 12 meters per second. The same numerical value for the speed of light works equally well at any season of the year. So the speed of light is constant. So Special Relativity theory is validated.

Response: (1) Except that it ignores the special frame needed – Earth-Centered Inertial/Geocentric frame, which means, if Geocentrism is not used, all Special Relativity theory times are invalid. (2) The speed of light is not constant, but only equal to c in the Geocentric frame. Satellites emit photons at $c \pm v$ relative to the ether.

Claim #10: The Sagnac effect can be regarded as arising from the relativity of simultaneity in a Lorentz transformation to a set of local inertial frames co-moving with points on the rotating earth. It can also be regarded as the difference between proper times of a slowly moving portable clock and a master reference clock fixed on the ground.

Response: This is very complex when compared to the simple statement of reality. The Sagnac effect occurs whenever there is motion or elevation with respect to the geostatic reference view, the Earth-Centered Inertial frame.

Claim #11: Special Relativity cannot be used to handle the case of objects and observers who are undergoing acceleration (non-inertial reference frames).

Response: Only velocity affects satellite clocks, not acceleration. (1) Cyclotron experiments have shown that, even at accelerations of 10^{19} g, clock rates are unaffected. (2) Consider acceleration with respect to the object's momentary co-moving inertial coordinates at any given instant. The accelerated motion can be considered as a sequence of inertial frames separated by infinitesimal time intervals. Special Relativity applies in each of these co-moving inertial frames, but at each instant the object is accelerating relative to its current instantaneous frame of reference. The object could be moving with a speed v tangentially to a center of attraction toward which it is drawn with a constant acceleration a . The path of such a particle is a circle in space of radius v^2/a , such as traversed by the Global Positioning System satellites. At any given instant the object is momentarily at rest with respect to a system of inertial coordinates, so we can define "proper" time and space measurements in terms of these coordinates. The object's acceleration causes continuous progression from one system of simultaneously co-moving inertial coordinates to another; the effect of this change will be seen in any time or space derivatives. At relativistic speeds, time and space axes are affected, so when the current frame of reference is projected back to the original or starting frame of reference, both time and distance are shortened. For an example, see the relativistic rocket problem in "Gravitation" by Misner, Thorne and Wheeler, section 6.2 or see the analysis at <http://mathpages.com/rr/s2-09/2-09.htm>. (3) Goldstein states:

Consider a particle moving in the laboratory system with a velocity \mathbf{v} that is not constant. Since the system in which the particle is at rest is accelerated with respect to the laboratory, the two systems should not be connected by a Lorentz transformation. We can circumvent this difficulty by a frequently used stratagem (elevated by some to the status of an additional postulate of relativity). We imagine an infinity of inertial systems moving uniformly relative to the laboratory system, one of which instantaneously matches the velocity of the particle. The particle is thus instantaneously at rest in an inertial system that can be connected to the laboratory system by a Lorentz transformation. It is assumed that this Lorentz transformation will also describe the properties of the particle and its true rest system as seen from the laboratory system.

Claim #12: General Relativity says that an object in free-fall is not acted upon by any forces (NB: gravity is not a force in General Relativity; rather, it is caused by space-time curvature) and, hence, defines its own local Lorentz frame. This applies to the entire Earth as well as the Global Positioning System satellites.

Response: The latest new Global Positioning System satellites are capable of inter-satellite tracking, which verifies the Sagnac effect. But the Sagnac effect should not exist in a freely falling frame without gravity (ether in Geocentrism). In fact, Michelson said that the orbital motion of the Earth around the Sun should be detectable in the Sagnac effect with a sufficiently huge ring interferometer covering the orbital path.

Claim #13: Special Relativity/General Relativity expects that the Global Positioning System would require an adjustment for the effect of the Sun's differential gravitational potential.

Response: (1) In the ECI frame used by Global Positioning System, clocks are not, and must not, be adjusted for the gradient of the Sun's gravitational potential. Hence, there is no valid explanation for this phenomenon, which is consistent with Special Relativity/General Relativity. This is very strong evidence that some form of ether theory is valid and that Einstein's Relativity theories are invalid. (2) Since there is only one ether that is not determined by Newtonian gravitation, Geocentrism predicts that the gravitational potential of the Sun has no effect on the Global Positioning System operation, which turns out to be the case. The Global Positioning System clock bias also ignores the effect of the Moon's gravitational potential, supporting Geocentrism and opposing Relativity theory.

Claim #14: The Sagnac effect cannot be used to detect the approximately one degree of rotation per day that is related to the equinoctial precession.

Response: Howard Hayden points out that the above proposition implies a Sagnac experiment using the inter-satellite communication links of the newer Global Positioning System satellites should yield a null result when computed relative to a frame rotating at a rate of once per year. If the abstract notion of time is slowed by decreased gravitational potential in General Relativity, no Sagnac effect should be measured. But if it is due to clocks that slow down as a function of the decrease in gravitational potential and a universal flow of time (independent of local clock measurements), then the proposed Sagnac experiment can be used to measure the angular rotation due to the orbiting Earth. The general

theory ascribes a change in the rate at which clocks run to an underlying, more fundamental change in the flow of time. Geocentrism ascribes the clock rate change to an environmental effect – the ether. Universal time is kept by the divinely mandated clock, that is, the motion of the celestial universe itself. It is the clock behavior that is changed, not absolute time. We can still expect to detect the Sagnac effect caused by the ether properties.

Claim #15: Global Positioning System clocks run at a rate determined by their relative velocity.

Response: In fact, the rate at which clocks run must be computed using the clock velocity with respect to an isotropic light-speed frame. This is consistent with the Modified Lorentz Ether Theory (MLET) of Ronald Hatch and with Geocentrism, but not with Special Relativity.

Claim #16: According to General Relativity theory, the frequency of the Global Positioning System signals increase as satellite height decreases.

Response: This would violate the conservation of cycles. More cycles would be detected on the ground than emitted by the satellite. The apparent gravitational increase in energy is not real. It appears to increase only because the standard of comparison (the energy radiated by a similar atom at a decreased gravitational potential) is decreased. The higher frequency of the Global Positioning System clock at its greater gravitational potential is in fact the source of the increased frequency and decreased wavelength of the received signal.

Claim #17: In the rotating frame of reference, light will not appear to go in all directions in straight lines with speed c . The frame is not an inertial frame, so the principle of the constancy of the speed of light does not strictly apply. Instead, electromagnetic signals traversing a closed path will take a different amount of time to complete the circuit.

Response: Rotation is only incidentally involved with the Sagnac effect, which is the result of a non-isotropic speed of light arising any time an observer or measuring instrument moves with respect to the Geocentric isotropic frame. Special Relativity requires that the speed of light always be isotropic with respect to the observer, an erroneous requirement, as Sagnac demonstrates.

Claim #18: The Sagnac effect is caused by acceleration and, thus, is properly handled by the General Theory of Relativity.

Response: The path of the radiation from the Global Positioning System satellite to the receiver clearly follows a straight line. This observation

validates the claim that the Sagnac effect is not caused by curvature of space-time, which would curve the light path. As noted elsewhere, acceleration within the Special Theory can be handled by successive infinitesimal Lorentz transformations (Lorentz boosts). If Lorentz boosts are used in the Sagnac experiment, no Sagnac effect can be expected, since the detector is always in an instantaneous inertial frame (with isotropic light speed). The velocity of light arriving at the detector from both directions ought to be the same at all times. But it is not.

Claim #19: Solutions have been offered to the Sagnac puzzle that rely upon ether-drag hypotheses, in which the speed of light is isotropic with respect to the gravitational field or the gravitational potential or the Earth's magnetic field.

Response: Charles M. Hill has shown by comparing Earth-bound clocks in the Sun-centered inertial frame with the millisecond pulses arriving from the Hulse-Taylor binary pulsar that clocks on the Earth have cyclic variations ascribed to the eccentricity of the Earth's orbit around the Sun. Geocentrism attributes this heliocentric view to the ether flow caused by the precession of the equinoxes, the annual North-South galactic motion. The component of this clock variation due to seasonal Milky Way and solar system motion clearly indicates that the Earth does not drag the surrounding ether with it, otherwise there would be no cyclic variations in the pulsar data. With the pulsar data we can now measure the variation in the ether flow.

Claim #20: The Lorentz Ether Theory (LET) says that any inertial frame we wish can be used as the isotropic light-speed frame—we simply cannot tell which frame is the true frame. Whichever frame is chosen as the isotropic frame, that frame defines an absolute simultaneity and observers moving with respect to that frame see anisotropic speeds of light.

Response: This is the flaw in the Lorentz Ether theory – there is only one universal absolute preferred frame in which c is isotropic: the Geocentric/Earth-Centered Inertial frame (ECI).

Claim #21: Stellar rotation must be greater than c , for their alleged great distances in the standard model of cosmology.

Response: The possibility of superluminality for Geocentric systems is inherent in Galilean relativity, which has no limit for the velocity of physical objects. The ether's limiting speed of propagation is also subjective at this time.

Claim #22: Nothing can travel faster than light in Special Relativity.

Response: Consider c_g , the speed of gravity – actually, the propagation speed of gravitational changes. Consideration of eclipses and binary star stability indicate that c_g must be at least 2×10^9 times faster than c .

Claim #23: Each clock in the Global Positioning System is synchronized *only* to an imaginary clock in the ECI frame, instantaneously co-located with the moving clock, and at a gravitational potential equal to sea level at Earth's poles.

Response: Suppose the clock rates were not biased before launch, but had their basic design rates in orbit. When Einstein-synchronized, the system of satellite and ground clocks would tick at different rates. In any inertial frame chosen, the corrections needed to synchronize with each orbiting clock would be unique to that frame and vary continuously because both clocks are rotating and accelerating. Operating the system would be a nightmare. In the actual ECI frame used in the Global Positioning System, the speed of light is constant only in that one frame, and not in any others. The practical difficulties for GPS in Special Relativity synchronization should have left some engineers wondering why the accepted dynamic model of Special Relativity caused such problems, while an absolute frame, which violates the consensus of professional scientists, provides a natural and unforced practical solution.

Claim #24: The Global Positioning System would work just as well in the Sun-centered or barycentric inertial frame as it does in the ECI frame.

Response: (1) There is a significant omission - the Earth's instantaneous orbital velocity is assumed to be constant in both frames. (2) Because gravity is assumed to be equivalent to 'space-time curvature' in General Relativity, Earth is treated as an inertial frame, even though it is orbiting the sun. Hence, the speed of light will be isotropic in ECI according to the Special Relativity postulate; and clocks will not need to be biased/offset to correct for General Relativity effects. But, of course, they actually do. In the sun's frame, the speed of light would not be isotropic on Earth, since the Earth is moving through the ether. But Poincaré's relativity principle (there is no observable difference between inertial frames) indicates that the one-way speed of light must somehow appear to be isotropic. In order to make the speed of light appear to be isotropic on the Earth, we must bias the clocks appropriately.

Additional comments:

- The ECI standard reference frame is equivalent to the Geocentric frame. The two terms may be interchanged.

- No real-time optical triangulation checks are carried out to verify that the satellites' true positions exactly match their predicted positions. Many don't realize that we do not know the actual positions of Global Positioning System satellites accurately; the ephemeris are based on models.
- In Geocentrism, one reference frame, ECI, is preferred; and speed cannot affect time as measured astronomically, but only the ticking rate of mechanical, electromagnetic, or biological clocks relative to the ECI frame.
- The speed of light is no longer a universal speed limit because astronomical time itself is never affected, either by motion or by gravity, but clocks are affected.
- When Relativity experts disagree, they can't all be right, but they can certainly all be wrong.
- Geocentrism clock behavior allows two clocks to be synchronized by comparing each with the Geocentrism frame using the usual rate formula: $f = (1 - v^2/c^2 - 2GM/rc^2)^{1/2} f_{gs}$.
- Clocks will remain synchronized in all frames when adjusted for the appropriate velocity and gravitational potential effects of the above gauge change.
- For clocks far removed from the Geocentric frame, the gravitational effect becomes negligible; the velocity is always with respect to Earth.
- Relativity isn't hard to understand, it's hard to believe.
- Tests of Relativity with the current Global Positioning System would be overridden by ground signals maintaining the satellite clocks within 1 microsecond of Universal Coordinated Time (USNO).
- Sagnac in 1913, Michelson in 1925 and Ives in 1941 all claimed that their published results were experimental contradictions of Special Relativity because they implied an absolute preferred frame.
- Global Positioning System satellites are being adjusted according to dependencies on the Sagnac effect and the gravitational potential, proven by Pound-Rebka, both of which dependencies do not require Relativity and have nothing to do with time dilation.
- The effect of velocity on clock rate is not consistent with Special Relativity predictions of dependence; but only on relative velocity between source and receiver.
- The 'constant' velocity of light is a fiction based on the illusion of proper time and Einstein's discordant prescription for clock synchronization.

When the velocity of light is measured with the GPS, we find that it is $(c - v)$ or $(c + v)$, in which v is the rotation velocity of the Earth

where the cities are located. Since all other particles are measured with additive velocities $(V - v)$ or $(V + v)$ with respect to a moving frame, why can't photons obey that same rule? Initial expectations based on special relativity were that clocks in different reference frames should have different readings and rates. Yet after pre-launch rate adjustment, all satellite clocks in all orbits remain in step with all other system clocks without further adjustment, as long as the master clock is Geocentric.

It is now widely believed that no experiment is capable of verifying these postulates, even in principle, because they become identically true – a tautology – if one adopts the Einstein clock-synchronization method. They are absolutely false if universal time is used, as in the Global Positioning System synchronization convention. Simply put, GPS uses universal time because it works!

In Special Relativity, any speed greater than c proved impossible because time ceases to advance for any entity traveling at the speed of light. In Geocentrism, the Galilean transform puts no limit on speed – recall that the speed of light in the Sagnac experiment for the co-moving beam was $c + v > c$. The upper limit for c would seem to be determined by the ether properties, which are yet to be fully explored.

In the Global Positioning System and the Geocentric frame, possible receiver motion during the signal downlink time from satellite to receiver must be considered for correct navigation results. In the Global Positioning System context, this downlink effect is called the “one-way Sagnac effect” and is attributed to the rotation of the Earth. The critical factor is the position of the satellite at the time the signal was transmitted and the position of the receiver at the time of its receipt. The path the receiver actually followed during the downlink time is unnecessary; the time depends only on the end-points of the path.

The GPS depends on relativity in 2 ways:

1. Source velocity (Global Positioning System satellite) and receiver velocity (ground device) affect the satellite and receiver clocks.
2. The gravitational potential affects satellite and receiver ground clocks.

Velocity Impact on Clocks:

The Global Positioning System satellites' clock rate and the receiver's clock rate are not adjusted as a function of their velocity relative to one another, but relative to the chosen frame of reference - the Earth centered, non-rotating, geocentric inertial frame.

By the analysis of hypothetical counter-rotating Global Positioning System satellites, Special Relativity theory can be shown to be in conflict with reality.

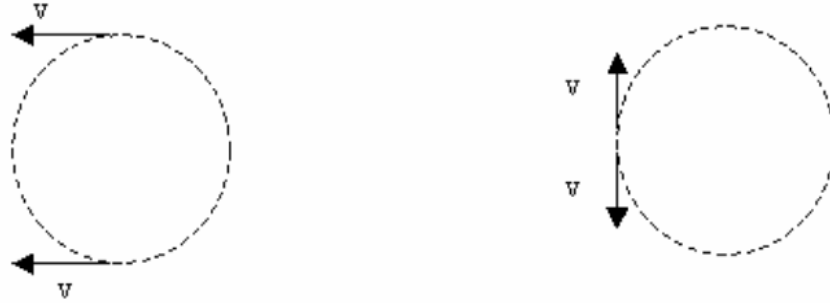

Counter rotating satellites

At left above, the relative velocity is zero; at right it is $2v$. In one half orbit the relative velocity of the Global Positioning System satellites would cycle from 0 to $2v$ and the relativity factor, gamma, would vary from:

$$1 \text{ to } (1 - 4v^2/c^2)^{1/2} \text{ to } 1$$

From either satellite, the general computed frequency f of a signal f_0 between them should be:

$$f = f_0(1 - v^2/c^2)^{1/2}$$

or a change in frequency in each quarter orbit of:

$$\Delta f = 0 \text{ to } 2 (v/c)^2$$

Note well: When the satellites pass each other, Special Relativity predicts a frequency change four times as great as above, while the Geocentric system predicts no change in frequency. In a system of 12 satellites in different orbital planes, synchronization management becomes horrendous. Yet this is what Special Relativity requires, if the Geocentric frame is not the rest frame. Special Relativity seeks to avoid this embarrassment by claiming that the speed of light is constant for both the observer and receiver if the Global Positioning System uses the Geocentric frame. This answer disingenuously claims the option of choosing the inertial reference frame that is most convenient; and in the case of GPS, this arbitrary choice is the Geocentric inertial frame. But this is not a matter of indifference, since using any GPS spacecraft or ground station as the observer in Special Relativity *does not predict the observed frequency shift*, only the absolute Geocentric frame does.

Direct Global Positioning System operational evidence supports the following: Whenever a frame is chosen that coincides with the Global Positioning System satellites, experiments show that the speed of light observed is *not* isotropic, that is, the same in both directions for the

observer or receiver. This is a direct contradiction of Special Relativity, which teaches that c is always constant relative to the observer. Likewise, Special Relativity's ineffective attempts to explain the Sagnac effect arise from the choice of a reference system that is not geostatic. The Global Positioning System's operational data indicate that the rate at which clocks run must be computed using the clock velocity with respect to a Geocentric frame.

Gravity Impact on Clocks:

The Full Gauge theory:

If Special Relativity's gamma or scale factor is generalized by gauge scaling to include the influence of a gravity field/potential, as suggested by Ron Hatch, then:

$$S = (1 - v^2/c^2 - 2GM/rc^2)^{1/2}$$

then the comparative clock rate is:

$$f = Sf_{gs}$$

where f_{gs} is the clock rate at the reference level, the Earth's surface.

The reference frame for v and r is the Geocentric system. There is no correction for the Earth's "rotation," and the scaling measures the ether effects in a non-geostatic frame. This simple extension of the kinetic energy as the total energy, including the potential energy of gravity, explains the anisotropic Global Positioning System observations of c (and other experiments covered here) without resorting to curved space or the staggering complexity of solving the General Relativity field equations. In fact, we propose that a future theoretical research project investigate the elimination of Special Relativity and General Relativity entirely by this simple scale change and show that all General Relativity "proofs" are supported by the S gauge transformation above (in the Geocentric frame, of course).

The S gauge factor, applied to three Global Positioning System experiments, shows that clocks run slower the lower they are in the gravitational field.

1. A Global Positioning System ground station clock at Colorado Springs runs faster because of its near mile-high elevation than if it were located at sea level.
2. Global Positioning System tracking stations confirm that all clocks at sea level in a Geocentric frame run at the same rate. Note that a clock at sea level at the equator runs at the same rate

as a polar sea-level clock, even though it is at a greater distance from the center (equatorial bulge), which should be a higher gravitational potential.

3. The eccentricity of the Global Positioning System's orbits causes the satellites to move up and down in the gravitational field. When the satellite is near perigee, it has a faster speed; and Special Relativity theory indicates that the clocks should run slower than normal. But near perigee the satellites have a lower (i.e., more negative) potential in the Earth's gravitational field that, according to General Relativity, should also result in a slower clock rate. The effects of different orbit motion and distance have precisely the same magnitude and sign, so they combine.

The requirement that the gravitational potential of the sun and the moon not be applied to Global Positioning System clocks using ECI gives very strong support to Geocentrism and ether theory. Unfortunately, physics has become a religion and Einstein has been accorded the status of a "God of Science". To question his theories has, up to now, been anathema.

The situation has become even more contentious for space probes and GPS satellites. The 1971 JPL document containing the equations used to model round-trip and one-way signals between a space probe and the Earth employed a Sun-centered isotropic-light-speed frame in which the probe and the detector (or observer) on the Earth are clearly moving. The JPL equations show that the speed of light was not assumed to be isotropic with respect to the observer. Instead, when a signal was in transit from the probe to the earth, it included the motions of the Earth observer, that is, Earth's spin, orbital velocity, and even the Earth-Moon barycentric motion. Although none of the engineers admit it, these equations ignore Special Relativity theory postulate II (isotropic light speed relative to the observer or sensor) and use the additive Galilean formula!

In the Hafele-Keating experiment, adjustment had to be made for the faster rate of clocks at the altitude of the aircraft on which they were carried. Shapiro showed that the gravitational potential of the sun causes radar signals reflected back from Venus and Mercury to be delayed when they are almost directly opposite the Earth in their orbits. All these experiments support the use of the gauge factor S in the Geocentric frame for gravitational effects on clocks

Anderson, Bilger and Stedman make the following statement:

The final suggestion of Michelson, that the orbital motion of the Earth around the Sun be detectable in a sufficiently gargantuan ring interferometer, is not consistent with general relativity: a freely falling point object (the whole Earth in this context) defines a local Lorentz frame.

If General Relativity interpretation were correct, no Sagnac effect should be measured in this global inertial frame. But if a Geocentric frame measures an absolute flow of time, independent of local clock measurements, then a Sagnac experiment can be used to measure the angular rotation of the firmament (apparently and conventionally assigned to the orbiting Earth).

Sagnac and Special Relativity:

Global Positioning System synchronizing of clocks around the globe using radio signals must take into account the Sagnac effect, since the stars move during the transit time of the signals to the ground station. The path of the radiation from the GPS satellite to the ground station receiver follows a straight line but is affected by the cosmic rotation, as Michelson and Gale showed. There is no centrifugal acceleration at the ground station, since that frame is GC/ECI. Special Relativity erroneously requires that the speed of light always be isotropic with respect to observers and the Sagnac effect exposes that error.

Sagnac and General Relativity:

The published General Relativity results applied to Global Positioning System operation (assuming they have been properly derived) are in conflict with Special Relativity to the extent that they do not give isotropic light speed with respect to the moving observer. All high precision Global Positioning System applications correct for the Sagnac effect, indicating that within General Relativity the speed of light is not always seen as constant by the moving observer.

Ether:

Special Relativity assumes the apparent equivalence of inertial frames is real. It uses that assumption with a universal c , to derive length contraction and clock slowing. Ether theories use clock slowing to show that the equivalence of all inertial frames and common universal speed of light is only apparent/phenomenological. Motion with respect to the ether and its density causes the difference in clocks compared to the absolute timepiece.

Using the Global Positioning System satellite relay system, electromagnetic signals have been found to travel slightly faster around the planet from west to east than from east to west. This implies that a weak ethersphere – the local firmament – actually moves west to east, counter to the main stellar rotation, which is east to west. If we assume this near zone ether/firmament is responsible for the mysterious westerlies in the temperate zones, then this ether must have zonal

motions similar to the global patterns of air circulation, as modified by solar heating and convection.

From the Sagnac analysis, Global Positioning System satellites would be affected by sidereal period fluctuations ranging from 0 ns (orbits perpendicular to ether flow) to 16 ns (orbits parallel to ether flow). However, fluctuation changes to their clocks could be interpreted as small variations from circular orbit, and so the effects can be masked. Other experiments besides the GPS can test the difference of synchronization between clocks, like the North-South displacements of clocks.



Time difference depends on path:

New York and San Francisco are approximately on the same latitude ($40^{\circ} 44'$ vs. $37^{\circ} 52'$). Radio signals sent directly between New York (N.Y.) and San Francisco (S.F.) using the Global Positioning System, as illustrated above, have a Sagnac delay of 14 ns for the E to W counter-rotational path across longitudes. This can be compared with a radio signal sent from New York to a satellite over the North Pole (N.P.) and re-transmitted to San Francisco. By correcting for additional delays from the greater transmission distance and re-transmission delays, we observe that the 14 ns difference now disappears, since rotation no longer affects the light speed. Another perspective is that the Sagnac area enclosing the angular velocity ω for the North Pole path is zero. In theory, the radio signals could be replaced by atomic clocks transported along the same path, but along the ground.

But will the clock increase its rate because of a kinematic effect - the tangential velocity of rotation decreasing at higher latitudes? No, since it has been shown that the shape of the Earth's geoid is such that

gravity potential difference between pole and New York is exactly the same for the loss of rotational velocity v . Both light/radio signals and physical clocks used for synchronization give an identical zero correction for the polar route. Both methods give 14 ns difference for the direct path across country.

The Geocentric description of all the above is based on replacing the rotating Earth with a rotating ether. The lack of temporal change when moving from NY to the pole is a result of the ether/firmament always terminating on the surface.

Two clocks in San Francisco and in New York will be in perfect synchronization if the polar route is used. But a radio signal westbound from NY to SF is faster than this by about one millionth (10^{-6}) of the total transmission time. A signal eastbound from SF to NY is about one millionth slower. This demonstrates the velocity of light with respect to an observer resting on the Earth surface is $c + v$ from NY to SF and $c - v$ from SF to NY. One must conclude that the velocity of light is isotropic with respect to a frame in which the Earth is at rest/non-rotating, which, in this case is the polar route! The velocity $c \pm v$, measured from a rotating frame, is viewed as a velocity $\pm v$ due to any linear motion through an ether flow, when measured from the absolute Geocentric system. Galilean relativity in a Geocentric frame of reference is the proper frame in which to compute dynamical physics.

The constant c of Special Relativity theory means that the distance from NY to SF is smaller than the distance from SF and NY – an absurdity to rational thinkers. The velocity of light is different in any frame moving with respect to the Geocentric Earth coordinate system. This difference is even programmed into the Global Positioning System computers for correct operations. We cannot escape that the experimental velocity of light with respect to a Geocentric moving observer is $c \pm v$.

In agreement with the rotating Mössbauer experiments, a reasonable ether theory would also predict that clock speed (or the speed of the gamma ray source or detector) through the ether affects the frequency. Ruderfer points out that the transit time effect and the clock effect would cancel each other so that a null result would be expected even in the presence of an ether drift. In spite of this correction experimenters continued to claim that it proved ether's non-existence.

The Lorentz Ether Theory (LET):

Two valid alternatives to the special theory are consistent with experimental evidence: Lorentz Ether theory and Geocentrism. Lorentz Ether theory incorporated both the Poincaré relativity principle and the Lorentz transformations, taking ether as the point of reference. Einstein added the equivalence of all inertial frames, eliminating the need for the luminiferous ether and making the Lorentz transformations reciprocal.

The second *postulate* of Special Relativity makes c independent of not only the source speed (also true for waves in any medium, like water, air and ether), but also independent of the observer's/detector's speed. The frame defined by the Cosmic Background Radiation (CBR) is assumed to be the absolute ether frame for the Lorentz Ether Theory, but just any arbitrary frame for the special theory. This view is said to be supported by the moon's much reduced aberration compared to the Bradley value for the stars – appropriate to its small speed through the CBR compared to the stars. In Lorentz Ether Theory, speed relative to the CBR causes clocks to slow and rulers to contract, but in Geocentrism, speed relative to the spinless Earth causes clocks to slow. Modern versions of Lorentz Ether theory hold that the preferred frame is not universal; rather, it coincides with the local gravity field of each celestial object.

Modified Lorentz Ether Gauge Theory (MLET):

Ronald Hatch has extensive experience in satellite navigation and communication systems, especially on GPS projects.¹³⁴⁰ Hatch, a former president of the Institute of Navigation and current Director of Navigation Systems Engineering of NavCom Technologies, is one of the world's foremost experts on the Global Positioning System. In Hatch's proposed alternative to relativity, MLET, the local gravity field of each celestial object serves as the "preferred Lorentz frame." The ether is not isotropic but varies locally with each object's gravity, thus losing its claim to being universal or absolute. This theory agrees with General Relativity to first order in v/c , but corrects many astronomical anomalies that General Relativity cannot without ad-hoc assumptions.

Historically, de Sitter, Sagnac, Michelson, and Ives all concluded from their own experiments that Special Relativity was falsified in favor of the Lorentz theory (LET). MLET predicts that on the Moon or planets their surface defines the reference frame in which c is constant. In Geocentrism, only the Earth has this property and is a true absolute frame.

Global Positioning System Synchronization with Sagnac:

The Sagnac effect has an important influence on GPS. It would be highly desirable to synchronize clocks in the ECEF frame. But this is prevented by the Sagnac effect. Inconsistencies occurring in synchronization processes conducted on the Earth's surface by using light signals, or with slowly moving portable clocks, are path-dependent and can vary by many dozens of nanoseconds, too large to tolerate in the Global Positioning System. Thus the Sagnac effect forces a different synchronization strategy.

¹³⁴⁰ <http://www.egtphysics.net/author/ronh.htm>

The Global Positioning System procedures for synchronizing clocks around the globe using radio signals must take into account the Sagnac effect, since the receiver moves during the transit time of the signal. The Global Positioning System engineers need the “Sagnac correction” in their computer program to calculate the exact GPS time, in addition to the relativistic corrections applied to offset the satellite clocks. As we have already seen, the Sagnac effect is itself inconsistent with the Special Relativity. The Sagnac effect is not a direct result of rotation or acceleration. It simply occurs any time the receiver is moving with respect to the Geocentric frame. If the receiver is moving in the Geocentric frame, the speed of light is not constant; and the Sagnac effect is simply the adjustment for the variable c . The experimental evidence is clear that it is invalid to perform instantaneous Lorentz boosts to simulate acceleration in Special Relativity to keep c constant with respect to the Sagnac phase detector. The Sagnac effect on Global Positioning System signals in transit proves that Special Relativity “magic” does not keep the light speed constant relative to the moving receiver. That Lorentz boosts are invalid is also supported by the aberration of the light from binary stars.

There is a measurable difference between Geocentrism and Special Relativity. The Sagnac effect clearly argues in favor of the Geocentrism. The Sagnac effect measures the inertial/rotational effect of space – the ether/firmament – on the counter-rotating light beams. The area dependence, A , in the Sagnac time shift:

$$\Delta t = 4A\Omega/c^2$$

measures the amount of firmament enclosed by the light paths. The possible different rotations represented by Ω include all those observed in the heavens:

- solar
- sidereal
- lunar
- equi-noctal precession

Rotating Mössbauer Experiments:

Unbiased analysis of the rotating Mössbauer experiment would have led to a conclusion opposite to that reached in the majority of experiments. Substantial independent experimental evidence exists that a moving clock (in the Geocentric frame) always affects the clock frequency. The null result of the rotating Mössbauer experiments actually implies that an ether drift must exist, or else the clock effect would not be canceled and a null result would not be present. The experiments actually favor Geocentrism rather than Special Relativity,

which is completely opposite the testimony given in textbooks on the subject.

The Global Positioning System is very similar to the rotating Mössbauer experiments with two differences:

- Ranges are the measured results in the Global Positioning System, not frequencies.
- The sources (Global Positioning System satellites) are rotating independently of the observers (ground receivers rotating with the Earth).

Universal time clock:

Some relativity proponents as well as some dissidents have pondered the method of capturing absolute or universal time with a physical device – that is, a clock. They suggest that:

- The rate of coordinate time would be determined by atomic clocks at rest at infinity.
- A real absolute clock would always use the same time rate, remote from and independent of local motions of source and observer. The observers would always look at this absolute clock, with a telescope if necessary.

How far have we wandered from Scripture. Although the advocates above have not recognized it, their “clock at infinity” is the heavenly clock we were given on Day Four in Genesis, the sun to rule the day and the moon and stars to rule the night. This celestial clock satisfies all the conditions required:

- Observable by anyone on earth, day or night
- Its perpetual motion never runs down
- Local terrestrial motions have no effect on it

Twin anti-paradox in Geocentrism:

In Lorentz Ether theory and Geocentrism, the answer to the twin paradox is simple: the Earth’s stationary frame constitutes a preferred frame. So the traveling twin always comes back younger, and there is no true reciprocity of perspective for any frames that are not equivalent to Geocentrism. Part of the problem addressing the twin paradox is the many different mutually incompatible solutions offered within Special Relativity. But all the solutions claiming to be consistent with Special Relativity involve changing inertial frames for the return trip of the traveling twin. The solution to the twin paradox in Geocentrism requires

the ECI frame as the absolute frame. If we never change frames and calculate clock changes on the rocket using:

$$f_i = (1 - v^2/c^2 - 2GM/rc^2)^{1/2} f_{gs}$$

then the slowing of the rocket's clock or, equivalently, decreased aging of the rocket twin compared to the Earth twin, will be observed by integrating the clock rate above over the actual rocket path. There will always be a cumulative greater aging of the Earth twin, hence, there is no paradox.

Ives-Stilwell:*Apparatus description*

The experimental apparatus allowed the observation of fast moving positive hydrogen ions in two directions, with and against the motion of the particles; the observations being made simultaneously by the use of a mirror in the tube. The displaced Doppler lines observed correspond to motion toward and away from the observer – a shift of the center of the displaced lines with respect to the undisplaced line.

In a glass tube ionized hydrogen atoms were created by passing a high-voltage spark through hydrogen gas.

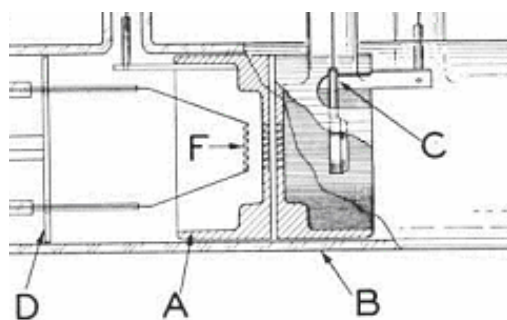

Ives-Stilwell equipment¹³⁴¹

- F, A, B are electrodes
- C is a mirror to reflect horizontal light back to the source
- On the right side of the tube is a spectrograph.

Hydrogen atoms ionized by the spark between electrodes **F** and **A** are accelerated towards the negative **B** by a high voltage between **A** and **B**. Hydrogen ions combine in flight with free electrons and radiate light in all directions with wavelength characteristic of the energy level difference:

$$\lambda = 4860.09 \text{ Angstroms.}$$

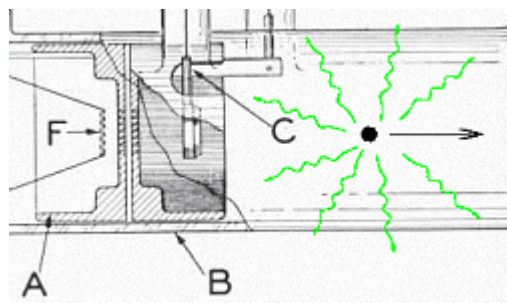

¹³⁴¹ N.E. Ives and G.R. Stilwell, J. Opt. Soc. Am., 28, 215-226 (1938).

Ives-Stilwell operation

Some light rays emitted by the ions move directly toward the spectrograph (black arrow above). Others move to the left, striking mirror C, and reflecting toward the spectrograph.

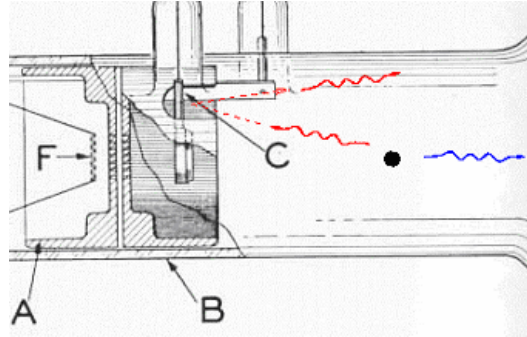

There are two types of rays detected, the light directly from the source ions (blue in above diagram), and indirectly from the mirror (red).

Transverse Doppler Effect Theory:

An ingenious way to see the transverse shift is by using two-photon spectroscopy. Two oppositely directed photons whose energy totals the excitation energy of a transition, are simultaneously absorbed by an atom. The first-order Doppler shifts are exactly opposite and cancel, leaving no first-order effect at all. For a moving atom the second order effect may be detected. Even the very tiny difference between ordinary and relativistic Doppler effects would cause a perceptible change.

Relativity theory interpretation:

In classical wave optics, the direct and reflected wavelengths, λ_d and λ_r , are

$$\lambda_d = \lambda(1 - v/c) = \lambda - \lambda v/c$$

$$\lambda_r = \lambda(1 + v/c) = \lambda + \lambda v/c$$

Relativity theory predicts:

$$\lambda_d = \lambda(1 - v/c)\gamma = \lambda(1 - v/c) (1 - v^2/c^2)^{1/2}$$

$$\sim \lambda(1 - v/c) (1 - v^2/2c^2) \sim \lambda(1 - v/c + v^2/2c^2) = \lambda - \lambda v/c + \lambda v^2/2c^2$$

Likewise,

$$\lambda_r = \lambda(1 + v/c + v^2/2c^2) = \lambda + \lambda v/c + \lambda v^2/2c^2$$

The sum of the two is computed:

$$\lambda_d + \lambda_r = 2\lambda + \lambda v^2/c^2$$

The first order terms cancel, allowing the second order relativistic term to be measured, a clever example of experimental technique.

Geocentrism interpretation:

Ives-Stilwell showed that the frequencies of radiating ions depended on their motion. The ions emitted at a specific frequency regardless from which frame they were observed. It seemed clear to Ives that nature needed a preferred frame, whose absolute motion would determine the ion frequencies. Otherwise, how would the ions know how often to radiate? It is all in the interpretation, the eye of the beholder. Relativists say the Ives experiment confirms Special Relativity, while Ives says it refutes Special Relativity and supports Lorentz Ether theory.

Claims and Responses:

Claim #1: The experiment shows that the frequency of the moving sources is reduced and given by

$$f = f_0 (1 - v^2/c^2)^{1/2}$$

a classically unprecedented Doppler effect that is characteristic to Relativity only.

Response: The transverse Doppler effect is not predicted by Newtonian physics, but it is so predicted by those alternatives to Relativity theory which provide for time dilation with the g factor, which is virtually all of them. Specifically, Geocentrism uses the scale factor S to confirm the Ives-Stilwell result.

Claim #2: In 1963, Walter Kundig performed a simple experiment on the transverse Doppler shift. A rotating turntable with a central radiation source and detectors on the rim guaranteed that the relative motion is always transverse. The change in frequency detected was due solely to time dilation, agreeing with Special Relativity theory to 1%

Response: All that can be said is that the frequency change was due to the effect of time dilation, Special Relativity theory being just one

possible theory to explain the results. The results of the experiment are therefore inconclusive in distinguishing Relativity or absolute motion theories.

Atmospheric circulation:

The conventional model

Global air circulation can be explained in a two-step model. The first starts with three simplifying assumptions:

- The Earth is not rotating in space.
- The Earth's surface is composed of similar materials.
- Solar heating and loss of infrared radiation cause a temperature gradient of hot air at the equator and cold air at the poles, forcing warm air away from the equator toward the poles.

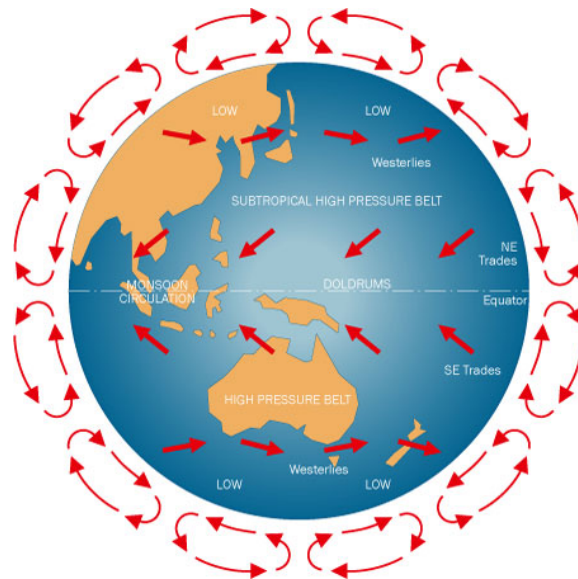

Air at the equator is lifted vertically by convection and convergence. It is then drawn to the poles by the thermal gradient. At the poles, the air cools and sinks to the surface to complete the flow cycle.

Now, let's change the first assumption to allow the Earth to spin in space. If so, planetary rotation would cause the development of three circulation cells in each hemisphere rather than one.

The Coriolis force:

Coriolis force causes upper air that is moving from the equator to deflect zonally from west to east at latitude 30° , which is the subtropical jet stream. The Coriolis effect also creates the Northeast Trades (right deflection) and Southeast Trades (left deflection). Surface air moving from the subtropics towards the poles is diverted by Coriolis acceleration to produce the Westerlies. Between the latitudes of 30° to 60° North and South, respectively, upper air winds blowing toward the poles are

influenced by Coriolis forces to flow west to east, the polar jet stream. The dominant cause of west to east winds is clearly the Coriolis force.

Aerodynamic inertia should cause upper level winds to move opposite to rotation, east to west, with the greatest speed at the equator, where the tangential speed is the greatest (1054 mph), but zero at the poles. Surface air at the equator should be dragged along at the tiny boundary layer at the same rotational speed as the equator, but should increase in speed relative to the surface with increasing altitude, finally approaching 1054 mph (relative to the surface, not an inertial frame).

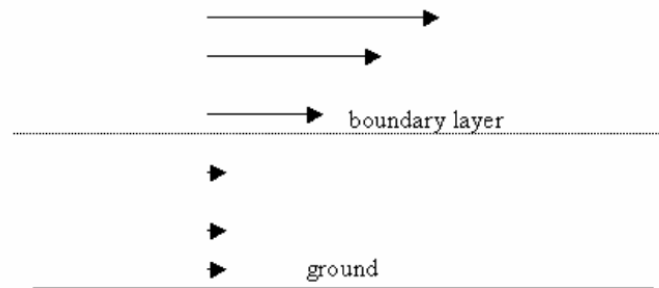

Wind profile with rotating earth and boundary layer

For an observer in an inertial frame far from the earth's rotational effects, the upper air would be stationary, the equator moving at 1054 mph. For a ground observer the surrounding air should be stationary and the upper air moving at 1054 mph. Let's see what sense this makes, if any:

A miniature version of the air circulation in cross-section can be seen when stirring a cup of coffee and then adding a few drops of cream. Or the satellite view of a hurricane reveals the same basic vortex pattern. The resulting principal atmospheric circulation winds should be east to west, the characteristic inertial motion of an Earth rotating from west to east underneath the air.

To understand the effect of rotation, set a solid ball spinning in a fluid as a model of the interaction of atmosphere with Earth. There should be a boundary layer at the surface with vortex lines spiraling out until the air is stationary with respect to an inertial system – the fixed stars (or the center of the Earth). The high altitude velocity profile with latitude angle lat should be:

$$v(lat) = 1054 \text{ mph cosine } (lat)$$

The velocity should exponentially increase with altitude at the equator from 0 to 1054 mph.

Based on the conventional Hadley cycle and Coriolis force model:

- If there is a jet stream anywhere it should be east-to-west, at the equator, but it is not.
- There is a Northern hemisphere mid-latitude west-to-east jet stream, but that is the wrong location and the wrong direction.
- There is a Southern high-latitude east-to-west jet stream, which is the wrong location.
- The highest steady winds at altitude anywhere seem to be about 50 knots, way below the rotational predictions.

Hence, it seems that the Earth is not rotating, but variable winds are caused by thermal and pressure gradients. Rotation only seems to be discussed in theory regarding the secondary Coriolis side effect, not the main feature, that is, the transition from an accelerated to an inertial frame. Remember, the Coriolis force is not unique to a rotating Earth; the same inertial forces would be present if the universe rotated around an immobile Earth. Mach's principle is still in effect, as always. But how can inertial winds of 1054 mph not play a significant role in a predictive model of terrestrial air patterns? It seems that no matter which choice for the atmosphere one takes – that it turns with or does not turn with the Earth – it defies either logic or observation.

If we are on a rotating Earth with non-viscous air subject only to gravity (i.e., the atmosphere is *not* coupled or bound by any forces to turn with the Earth), then we would experience tremendous wind problems, in which the spinning Earth encounters the full weight of the atmosphere. (NB: The atmosphere weighs more than 4 million billion tons.) The minor thermal differences between poles and equator would be wiped out by the blast of west-to-east air, that is, the collision of free air and the spinning Earth.

Conversely, if we are on a rotating Earth and somehow this atmosphere is turning with us, what is the coupling mechanism that enables it to do so? It must have some link to provide the torque to continue the coordinated rotation of the Earth with its wrapper of air. Would not a co-turning atmosphere and Earth mean nothing else could move the air? Otherwise, is not the air was acting as a solid, not a gas? No one has proposed a mechanism for this connection of the supposedly spinning Earth to the supposedly spinning air that is so strong that the atmosphere is forced to spin along with Earth, though otherwise it is free to move anywhere that gravity permits! We easily demonstrate the air's freedom every time we walk through it or breathe it. Yet, we are told, the air obediently follows the Earth as it twirls through the heavens.

Perhaps other planets with atmospheres can resolve this. Venus is virtually spinless; it rotates once every 243 days, with a paltry 5 mph equatorial surface speed. The upper atmosphere should be calm, but that is not the case. The wind pattern follows the spinning ball in a fluid model, with 200 mph east-to-west winds at the equatorial high altitudes,

decreasing with increasing latitude and decreasing altitude, as expected, in fact, on Earth! Are there two jet streams, in opposite directions in each hemisphere, like Earth? No. High in the atmosphere the winds decrease with latitude, as the rotation model predicts. It is sort of one big jet stream at altitude, tapering off away from the equator.

Note these words from an unusually forthright planetary meteorologist:

Although much is known about wind patterns at Venus on a global scale, still more is unknown. It has been proposed that any planetary atmosphere is a chaotic system, meaning that there exists an underlying order about the system which, if understood, could result in accurate predictions of its details even on a small scale. However, this underlying order is unknown even for our planet, and still less is known about the Venusian atmosphere. Until that underlying order is known, the best course of action in attempting to model an atmosphere is to assume that its characteristics are truly random on all but the most global of scales.

Even this open admission of ignorance in global atmospheric physics is too conservative. We have seen that even the gross movements of the global air circulation cannot be reconciled with the rotation of the Earth underneath it. Except for stronger winds of 28,000 mph, Jupiter resembles Venus at the equator, as well as its absence of distinct jet streams. Saturn has rings as well as surface zones. Winds in the zones can be three times those of Jupiter, greater than 75,000 mph! But these two planets rotate 2.5 times faster than Earth's alleged rotation, yet the equatorial winds on Jupiter and Saturn are as much as 1,000 times faster than on Earth! The whole area of rotational effects on planetary wind circulation is very puzzling. In all the references consulted, no one seems concerned about the huge gulf between theory and reality – a hallmark of modernism.

Part 2

Geocentrism says only the Earth doesn't move; the rest of the cosmos does. Anti-geocentrism (AGC) says the Earth moves. There are 3 modernist anti-geocentric claims:

- (a) Rotation claim:
- (b) Heliocentrism Claim: Earth moves around the Sun every year.
- (c) Linear claim:

Part 2 covers the heliocentric claims that the Earth has an absolute and unique orbital motion around the immovable sun, the center of this system.

The Geocentric tenets are:

1. The foundations of the Earth do not move.
2. The sun, moon and stars (including planets) move.

The most vocal claims against geocentrism are usually centered on the optical phenomena known as parallax and aberration. It will be important to establish the difference between these often confused terms before putting to rest any merit to the idea that they disprove geocentrism.

Parallax versus Aberration

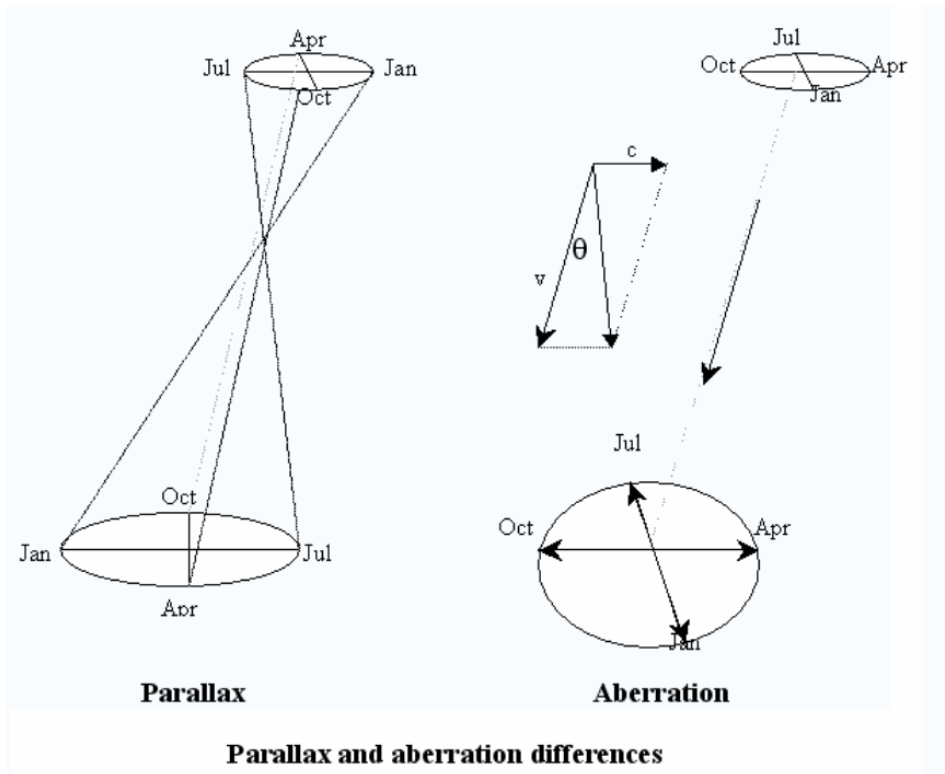

The ellipse patterns formed by parallax and aberration are similar and, indeed, are superimposed for nearby stars. But the two stellar effects can be separated, as discussed below in heliocentric terms.

Because of the yearly change in position of the Earth, the direction in which a star is observed changes annually, as indicated above-left by the 4 months on the Earth's orbit. Unlike aberration, the parallax angle is proportional to the ratio of the diameter of the Earth's orbit to its distance from the star. Bradley observed a different periodic variation in the apparent position of stars, reflecting changes in the *velocity* rather than in the *position* of the Earth over the course of a year. This aberration effect is illustrated above right, where the star is so far away that its parallax is unobservable. The actual monthly star positions (ellipse above) correspond to the observed monthly star positions on the ellipse below, with arrows indicating the direction.

The variation on the right cannot be due to parallax, since it lags behind the variation one would expect on the basis of parallax by roughly three months. In diagram at right, the angle between the direction of light with aberration ($v \neq 0$) and without aberration ($v = 0$) is θ , the aberration angle. The tangent of θ is proportional to the ratio of v , the velocity of the Earth in its orbit around the sun, and to c , the velocity

of light. The tangent is small, so the angle θ itself can be used instead, but the angle is still considerably larger than that of parallax.

Summary:

There are three notable differences between the ellipses of parallax and aberration:

1. The aberration ellipse is much bigger: (20.5 arc-seconds vs. < 1 arc-second).
2. The aberration major axis is the same for all stars: 20.5 arc-seconds but the parallax major axis depends on the star's distance.
3. The phase is different. In parallax the image is 180° away from the image, in aberration it is 90° away. Alternately, when the sun and star have the same longitude, then the *longitude* shift is zero with parallax but the *latitude* shift is zero with aberration.

Note the following data:

[Key: ✓ = supported; 0 = neutral or does not apply; X = disproof]

G = Geocentric

H = Heliocentric

E = Ether

S = Special Relativity

R = General Relativity

Experiment	Type	G	H	E	S	R
Galileo: Jovian moons ~1609	His observations showed four moons were actually orbiting around Jupiter. Here was incontrovertible proof that the Earth was not the center of the Universe.	0	0	0	0	0
Geocentric Response	Geocentrism would only be disproven if Jupiter or its moons were stationary. This is instructive in showing the difference between revealed Geocentrism and the human fallible models that try to implement Geocentrism.	0	0	0	0	0
Galileo Venus phases ~1609	Venus cycles through a complete set of phases, just like the Moon. Venus is never very far from the sun so in the Ptolemaic system Venus should always be in crescent phase as viewed from the Earth because it can never be far from the direction of the sun which always lies	0	0	0	0	0

Experiment	Type	G	H	E	S	R
	beyond it. Since Venus did not go around the sun, we would never see all sides of it. But the Copernican model does account for the phases.					
Response	Again, a fault in a particular model of Geocentrism does not disprove it, but shows the model needs correction. Venus orbits the sun in both Copernican and Tycho's models, but the sun orbits the Earth only in Tycho's model, consistent with Geocentrism.	0	0	0	0	0
Galileo Tidal flow ~1609	Just as water sloshes back and forth in a swinging container, Galileo reasoned that the Earth, as a giant vessel spinning on its axis, might cause the seas to rise and fall twice a day. The tidal motions of the Mediterranean offered proof that the Earth moved.	0	0	0	0	0
Response	Even modernists reject this theory, attributing the tides to the Moon's motion around the Earth. (The only motion with which Geocentrism and modern physics agree is the motion of the Moon around the Earth.) Caution: Even here the lunar cause of tides may be only be indirect; the ether flow varies with latitude, which is the direct cause of the two tidal bulges!	0	0	0	0	0
Stellar: Bradley 1727	Annual aberration proves that light has a finite speed and that the Earth is moving around the sun. This is inconsistent with a simple model of light as waves in an ether which is dragged along by the Earth; it is consistent with Special Relativity.	X	✓	0	✓	0
Response	Bradley's formula explaining aberration is based on a Copernican model, which conflicts with the Relativity paradigm. Neither is correct in the geocentric model, where stellar aberration is intrinsic to the motion of all the stars, not an apparent optical effect caused by terrestrial motion. It is similar to the higher order motions of the sun and moon and planets, their actual or proper motions undistorted by deviation from geometrical optics.	0	0	0	X	X
Diurnal /daily	Diurnal aberration is caused by the velocity of the observer on the surface of the rotating Earth. It depends on the local	X	✓	0	✓	0

Experiment	Type	G	H	E	S	R
	time and location of the observer. Much smaller than that of annual aberration, it is only 0.32" at the equator, where the rotational velocity is greatest.					
Response	Just like the annual aberration, the daily pattern is caused by the motion of the ether, not N-S but the principal daily E-W motion. Both are ether effects.	0	0	0	X	X
<u>Binary star</u>	Doppler shifts of binary stars indicate their radial velocity, but this same velocity when tangential to the view from Earth does not produce the expected corresponding stellar aberration. During the period of the orbiting star in a binary system, that star should oscillate due to aberration, using the relative velocity between the source and the Earth. The smaller star in binary systems generally has velocity components much larger than the Earth's orbital velocity.	0	0	0	✓	0
Response	If the aberration is due to relative motion, there should be a very large stellar aberration seen from Earth, 10 and even 100 times larger than the amplitude observed by Bradley. This aberration from those fast moving stars is totally absent, even if the relative velocity with respect to Earth is very large. All these observations contradict the principle of relative motion. Bradley even deduced the Earth's velocity around the sun, contrary to this cherished principle.	0	0	0	X	X
<u>Planetary</u>	Planetary aberration of any solar system object is the combination of the aberration of light due to Earth's orbital velocity and light-time correction due to a planet's distance from earth. Both are determined at the instant when the object's light reaches Earth. The prediction for individual planets is uncertain.	0	0	0	0	0
Response	The computations are greatly confused by the antagonism between the Bradley and Special Relativity theories. Discussion of experimental results are hard to find.	0	0	0	0	0
Solar light	The limb of the sun cannot be determined to the accuracy needed to determine its aberration.	0	0	0	0	0

Experiment	Type	G	H	E	S	R
Solar wind	The solar wind is a stream of charged particles, mostly protons and electrons, emitted by the sun's surface. On the average, it appears to come not directly from the sun but 4 degrees behind the sun's position, due to the orbital velocity of the Earth. In the frame of the Earth the solar wind appears to move as if it had the Earth's velocity, but in the opposite direction.	X	✓	0	0	0
Response	The solar wind aberration can be explained simply by reversing the words "solar wind" and "Earth" above. Why do the followers of Special Relativity never want to use the static Earth possibility, which viewpoint Special Relativity allows as much as a moving Earth?	0	0	0	0	0
<u>Moon</u>	Refers to the motion of the moon as seen from Earth. Like the sun, the moon is not an astronomical point source, with an ill-defined limb. What speed should be used for lunar aberration computation? The Bradley value of 30 km/s, the orbital speed of the detector on earth? The relative speed of the Earth - moon system?	0	0	0	0	0
Response	Well, it does not matter. They are both wrong. Lunar laser ranging (LLR) experiments (bouncing laser beams off retro-reflectors placed on the moon by astronauts) shows there is no aberration. The moon is really where it appears to be. Why no lunar aberration? It is almost as though the Earth weren't moving, but Who would ever say that?	✓	0	✓	X	X

Experiment	Type	G	H	E	S	R
Satellite to Star	For Bradley the aberration would be a constant 20". For Special Relativity the periodic motion of the LEO orbit satellite adds a $\pm 5''$, so the aberration varies from 15" to 25", as observed.	X	✓	0	✓	0
Response	But what about the motion of the solar system and galaxy at hundreds of km/s? Why are these motions ignored, though much greater than orbital motions? Special Relativity ignores what doesn't fit. The geocentric model explains the 20" stellar aberration of Earth as the actual intrinsic motion of the stars (or an ethereal effect). The satellite contribution of 5" is a true aberration, correctly predicting the stellar aberration when seen from a satellite (Hubble).	0	0	✓	0	0
Satellite downlink	Its speed is 8 km/s and period is 97 mins, which is 18 times the Earth's rotation. For Bradley, downlink signals from Hubble should have an aberration at the ground stations of 20", just as the stars do. For the relative motion of 8 km/s [not the heliocentric system used for the stars] the aberration formula for equatorial motion (latitude angle = 0) predicts $\theta = v/c = 8/3 \times 10^{-5} \text{ km/s} \sim 5''$, in good agreement with the measured and easily visible aberration of 5.8"	X	✓	0	✓	0
Response	The downlink should only have the travel time delay. There is no aberration for the geocentric model. For a LEO orbit of 8 km/s, the delay deflection should be about 5.3 arcsec, in good agreement with 5.8" measured.	✓	0	0	0	0
Satellite Uplink	Shows the same aberration for laser signals sent ground to satellite or satellite to ground. A patent for a 'velocity-aberration correcting retroreflector satellite' ¹³⁴²	X	✓	0	✓	0
Response	The satellite in motion at 8 km/s should receive an aberrated signal from the stationary Earth of 5.3", again in agreement with the measured uplink aberration.	✓	0	0	0	0

¹³⁴² <http://www.freepatentsonline.com/5474264.html>

Experiment	Type	G	H	E	S	R
Earth	As always, Bradley predicts 20" aberration for objects seen on Earth from Earth, since neither source motion or distance affects Bradley aberration. 0" is actually observed. Special Relativity predicts 0" from the relative motion of surface objects.	0	0	0	✓	0
Response	Geocentrism predicts 0" aberration for surface object motions much less than c .	✓	0	0	0	0
Fresnel 1818-30	The first quantitative proposal to measure ether properties. Fresnel proposed that substantial material bodies might carry some of the hypothetical ether along with them. Fresnel ether dragging by massive objects was based on a coupling constant that modified the speed of light in transparent media.	0	0	X	0	0
Response	At this time in history the only known way of reconciling aberration with wave theory was Fresnel partial dragging. The 'ad hoc' remedy of Fresnel drag gave heliocentrism a temporary reprieve, but still the question of geocentrism or heliocentrism was not resolved.	0	0	0	0	0
Stokes 1830	Stokes proposed a "Silly Putty" model of the ether which behaves as a rigid solid for the high-frequencies of light and as a fluid for the slower motion of celestial bodies. At the Earth's surface, the ether will be stationary. A realistic model of the ether but more complicated. Stokes differed from Fresnel's partial dragging theory by interpreting stellar aberration as due to an ether that was totally, not partially, dragged along next to the Earth.	0	0	X	0	0
Response	Stokes' theory of a completely dragged ether was unsuccessful.	0	0	0	0	0
Faraday Rotor Generator 1831	Faraday found there is an induced current if a conductor and a magnet are joined together and rotated, having no relative motion. He resolved this paradox by saying the lines do not rotate when the magnet does. In the inertial laboratory frame, the axis of the magnet is at rest when the magnet rotates: in the same	0	0	0	✓	0

Experiment	Type	G	H	E	S	R
	reference frame, also Faraday's lines of magnetic force are at rest.					
Response	Faraday's law does not apply to this machine. There is no changing magnetic flux. The conventional resolution of the paradox follows the usual path; it ignores the simple observation that motion measured with respect to a spinless Earth has special significance. The geocentric theory solves the Faraday paradox as well as the contrived special cases of mainstream physics.	✓	0	✓	0	0
<u>Geometric Parallax</u> 1838	As the Earth moves over huge distances in orbiting the sun, nearby fixed stars are seen to move more, relative to the farther ones, as can be seen from a moving car. Parallax is smaller than aberration; it required waiting for telescopes to improve before stellar parallax caused by the Earth's orbiting of the Sun could be detected by Bessel in 1838.	X	✓	0	0	0
Response	This is the first false "proof" of heliocentrism, which is often cited as disproof of Geocentrism. Despite the simplicity with which these claims can be refuted, it survives today even among modern cosmologists who should know better. Parallax is fine for determining distances, but for finding a fixed point it is worthless.	✓	0	0	0	0
<u>Arago</u> 1850	Arago looked for the expected change in focus of a refracting telescope due to Earth's motion around the sun. This is first order in v/c if one assumes light is fully dragged by the lens. Arago compared the focal length of light from a particular star at six-month intervals. The Earth's motion should alternately add and subtract the Earth's orbital speed to the speed of light, but there was no difference.	0	0	0	0	0
Response	The null result is consistent with geocentric theory. It is due to null motion of the Earth	✓	0	0	0	0

Experiment	Type	G	H	E	S	R
Fizeau 1851	Fizeau measured the speed of light in moving materials. Light was dragged through moving water; fringes observed due to motion of the water agrees with Fresnel's drag formula. No effect seen, due to the motion of the Earth, is interpreted as very strong evidence for ether dragging. The Fresnel drag coefficient is solidly established by experiments, and is consistent with Special Relativity to within experimental limits.	0	0	✓	✓	0
Response	No effect due to the Earth's motion could obviously mean that the Earth is not in motion. Why invent a counter-intuitive concept of the immovable ether being dragged by matter? If anything makes sense it would be the ether dragging matter, not the reverse. Lorentz derived the Fizeau result without using relativity; the Galilean transformation also derives it with a variable c . Several causes can be given for the Fizeau result.	✓	0	✓	0	0
Hoek 1868	An interferometer experiment with one arm in water. Greatly improved the accuracy of Arago's experiment, replacing the telescope with a terrestrial source and a square (ring) interferometer with one side in water and three in air. The null result is consistent with Arago's result, Fresnel's drag coefficient, and Special Relativity.	0	0		✓	0
Response	No fringe effect was seen at all, and no explanation given for a result so contrary to Fizeau's. As in many other tests, the ether's existence is rejected, instead of accepting a motionless Earth.	✓	0	0	0	0
Airy 1871	Another test for ether's presence. Does a telescope filled with water cause an image shift? Does the stellar aberration angle change if the telescope was filled with water? No! George Airy tested whether water in a telescope would cause the light to bend (refract) at a larger angle. If the Earth was actually moving, the beam should deflect more; if the starlight were moving, there should be no change.	0	0	X	0	0
Response	Another false disproof of Geocentrism -	✓	X	✓	0	0

Experiment	Type	G	H	E	S	R
	Airy's failure showed deflection happened outside the telescope: (1) Due to the ether in space between Earth and star, (2) The deflection originated in the source => the stars inherently move in aberrant ellipses. So the star was moving and not the Earth. "Airy's failure" failed to prove that the Earth revolves about the Sun. No evidence compels us to believe the Earth is spinning.					
<u>Michelson-Morley</u> 1887	In 1880 Maxwell hinted the absolute velocity of Earth in the "luminiferous ether" that carried electromagnetic phenomena may be optically detectable. Michelson-Morley tried to detect the motion of the Earth through an absolute space – the ether. The famous null result was interpreted as showing a single "universally fixed" ether does not exist; either space moves with the Earth (ether drag), or there is no ether. Stokes' dragging became the standard model. The failure became significant in promoting the acceptance of Einstein's theory of Special Relativity, that physics laws only require the motion of the Earth relative to other matter, not relative to an ether.	X	0	X	✓	0
Response	The null result includes the rational option of the Earth being at rest. The refusal to even consider the possibility that this was true, and that Galileo and all science for centuries had been wrong, disproves the posture of modern science being objective. Even the null result wasn't really so, as Miller and others showed in later tests. There were daily and annual variations that have great importance for geocentric theory, as we shall see.	✓	X	✓	X	0
<u>Oliver Lodge</u> 1892	In response to ether drag/entrainment, Lodge noted that the effect is undetectable around rapidly moving celestial bodies like planets. He verified experimentally that even in very close spaces the ether is not entrained by its surroundings when they are put into rapid motion.	0	0	0	0	0
Response	Geocentric theory of the ether includes the slight drag of free particles (gases) in the ether flow. Ether drag by matter is	✓	X	✓	X	X

Experiment	Type	G	H	E	S	R
	rejected as confusing cause and effect. So the Lodge experiments do, indeed, support Geocentrism.					
<u>Trouton-Noble 1903</u>	The Trouton-Noble experiment attempted to detect motion of the Earth through the luminiferous ether. This classic experiment is regarded as the electrostatic equivalent of the Michelson-Morley optical experiment, though achieving the necessary sensitivity may be impossible. It looked for a torque induced on a charged capacitor due to its motion through the ether. Its null result is consistent with Special Relativity.	X	✓	X	✓	0
Response	The effect of ether flow on charges bound in a solid is most likely undetectable, based on studies by Cahill on the need for gases with enough degrees of freedom to respond to the motion. To be compliant with the Miller comment on the Michelson-Morley experiment, this experiment is best done at altitude in the open. As an ether test, this experiment is a non-starter.	0	0	0	0	0
<u>Trouton-Rankine 1908</u>	Spelled the end of the Lorentz-Fitzgerald contraction hypothesis by achieving an incredible sensitivity. Regarded as the electrical equivalent to the Kennedy-Thorndike experiment, it was designed to measure if the Lorentz-Fitzgerald contraction of an object in the absolute ether produced measurable effects in the object's rest frame. This test showed that, if the Lorentz-FitzGerald contraction existed, it was not measurable in the rest frame of the object.	0	0	0	X	X
Response	Geocentrism is rooted in reality; the results are what are expected. There is no need of mystical contraction of matter in the direction of motion, with no explanatory physical mechanism. The mystery is why anyone would reject a static Earth in favor of the bizarre Lorentz contraction hypothesis.	0	0	0	X	X
Zurhellen 1914	Binary star observations determine that the speed of light is not dependent on	0	0	X	✓	0

Experiment	Type	G	H	E	S	R
	movement of the source to 10^{-6} . This is evidence against ether drag if each binary component has its local ether shell with its alternating effect on c . Also, shell distances are minute compared to star-Earth distances. Evidence for the lack of longitudinal additions to the velocity of light by the radial motion of the source.					
Response	No, ether drag supports Geocentrism. Special Relativity predicts an active aberration effect produced by the motion of the source in its rest frame, the barycenter of the binary system. Bradley aberration is caused by absolute motion of the Earth around the sun. Yet standard physics attributes aberration to their relative motion, supported by exclusive authorities such as Einstein and Pauli. This experiment fails to support relativistic predictions for transverse motion of the source.	✓	0	0	X	X
<u>Kennedy-Thorndike 1932</u>	Kennedy-Thorndike used an interferometer with arms of different lengths and not at right angles. A null result is obtained, consistent with Special Relativity, implying length contraction and time dilation. Apparatus was fixed to the Earth, forcing co-rotation. No diurnal or seasonal variation was seen. Also a Special Relativity test to verify time dilation: no phase shifts will be detected in Special Relativity while the Earth moves around the sun, while such would result from length contraction alone.	X	✓	X	✓	0
Response	Special Relativity is verified because time stretches and lengths contract to produce the null?? A better option is <i>terra immobila</i> and ether flow, with no wild speculations about space and time needed. With the Trouton/Noble test, Kennedy/Thordike eliminated Lorentz contraction as a viable option. The test was doomed at the start by bad choices: enclosing the equipment from the ether, and, fatally, using a vacuum interferometer that precludes an ether-matter interaction. With such fundamental faults, Kennedy/Thorndike should be ignored.	✓	X	0	X	X

Experiment	Type	G	H	E	S	R
Hamar 1935	A complete Michelson-Morley experiment with one of the interferometer arms placed between two massive lead blocks. If ether were dragged by mass, the blocks would cause a visible effect. Ether dragged by the mass was not detected; again the null result was found.	X	0	X	✓	0
Response	The ether was already reduced by the building housing the laboratory; additional partial shielding would not be measurable. The theoretical principle is sound, but it should have been done outside, so that ether could be measured with and without the lead blocks	✓	X	✓	X	0
Townes 1958	Townes, one of the co-creators of the first maser, replaced the light source in the Michelson interferometer with a ruby maser and repeated the Michelson-Morley experiment. The upper limit on drift, including any possible experimental errors, was only $30 \text{ m/s} = 10^{-7}c$	X	0	X	✓	0
Response	The faults of the Michelson-Morley experiment remained – The criteria of Miller for a high and unobstructed location and of Cahill for a refractive gas.	✓	X	✓	X	0
Frisch-Smith 1962	Shows that radioactive decay of mesons is slowed by motion. Mesons live longer by time dilation – a confirmation of Special Relativity.	0	0	0	✓	0
Response	<ul style="list-style-type: none"> • Time dilation is common to many alternate theories • It neither proves Special Relativity theory uniquely nor conflicts it. • Special Relativity theory is not applied correctly in the analysis, since Lorentz contraction is ignored. • Other tests show Lorentz contraction doesn't exist. • If time dilation is true, the best current thinking of Geocentrism is the S gauge scale factor of Hatch. 	0	0	✓	X	X

Experiment	Type	G	H	E	S	R
Trimmer 1974	The first c test with lasers. Repeats Michelson-Morley experiment with accurate lasers and a triangle replacing the square Michelson-Morley path. Included tests of entrainment by placing one leg in glass. Ether drift now reduced to $0.025 \text{ m/s} = 10^{-11} c$	X	0	X	✓	0
Response	The laser only reduced the probability of ether detection. Use of vacuum or solid media in the optical path violates the gas media requirement.	✓	X	✓	X	0
Brecher 1977	Repeats 1914 Zurhellen experiment with X-rays from binary pulsars. For x-rays and gamma rays, the extinction distance is much larger than the distances to many binary star systems, allowing a test of DeSitter's proposal. Observations put a limit on the source-velocity dependence of $c < 2 \times 10^{-9}$.	0	0	X	✓	0
Response	Other than the extinction test and use of high energy electro-magnetic waves, the results mirror prior testing with light. See Zurhellen 1914.	✓	0	0	X	X
<u>DePalma Spinning Ball Drop 1977</u>	DePalma took two steel balls and catapulted them into the air at equal angles, with an equal amount of force. The only difference was that one ball was rotating 27,000 times per minute and the other was stationary. The rotating ball traveled higher into the air and then descended faster than its counterpart, which violated all known laws of physics.	0	0	✓	0	0
Response	Mainstreamers usually ignore this effect, or ridicule its violation of the laws of Newton and Einstein. With so few investing time to verify and understand the effect, its location in the physics closet is understandable. Primitive ether theories now proposed will no doubt be improved, but more eyes and minds are needed, not abuse from the paradigm-huggers.	0	0	✓	0	0
<u>Gyro Drop 1977</u>	Observations of interaction of gravitational and inertial forces on a falling gyroscope reveal a slight enhancement of inertia by the gravitational field. A rotating mass will fall more rapidly, with greater	0	0	✓	0	0

Experiment	Type	G	H	E	S	R
	acceleration than an equivalent non-rotating mass.					
Response	Further support for the Depalma spinning ball results	0	0	✓	0	0
<u>Quantum red shifts</u> Tiftt 1984	Tiftt found that galaxy red shifts take on preferred or quantized values. Analogous to the energy levels within atoms, there was a periodic grouping of galaxy red shifts around discrete values across the span of the universe.	0	0	0	X	X
Response	There are no modernist cosmology theories that can account for this architecture of the universe around the Earth, one of the simplest and strongest proofs of geocentrism.	✓	X	✓	X	X
<u>Red shift anomaly</u> 1990	The annual change in Doppler shifts we see in stars near the ecliptic is one proof that Earth orbits the sun; the wavelengths go back and forth each year, changing slightly to red as we move away from a star and then to blue when we're on the other side of our orbit moving toward the star.	X	✓	0	✓	0
Response	Is this an urban legend? Where is the data? No references are given for the significant detailed sky survey required, nor can one be found by research. More significantly, by mathematically subtracting the Earth's motion, the reverse effect is accomplished. If the Earth is actually at rest, the "heliocentric correction" will corrupt the data with false motions of rotation and revolution. The red shift anomaly is a paragon of false reasoning – fixing something that isn't broken!	0	0	0	0	0
<u>Cosmic Mega Walls</u> 1990	The universe is crossed by at least 13 vast 'walls' of galaxies, separated by about 420 million light years, according to researchers. The walls are spaced in a very regular way that current theories of the origin of the universe cannot explain.	0	X	0	0	0
Response	The same inference can be drawn here as with the Tiftt red shift quantum, except the scale is much bigger. The inference?	✓	X	0	0	0

Experiment	Type	G	H	E	S	R
	The Earth is enclosed by shells of galaxies and is the focus of the universe. The same weakness is also present here – reliance on the Hubble law.					
Hils/Hall 1990	Repeat of the Kennedy-Thorndike and Brillet-Hall experiments, with lasers fixed to the earth for better stability. Found there was no shifting $> 2 \times 10^{-13}$ m/s. Year long observations put a limit not only on anisotropy, but also on variations in different inertial frames and universal motions. No annual variations of the round-trip speed of light were found in different directions or for the different inertial frames occupied by the Earth.	X	✓	X	✓	0
Response	As with Brillet-Hall, the experimental precision means nothing if ether detection is eliminated by use of a vacuum path. This is a protocol defect common to most modern ether tests – the vacuum interferometer.	✓	X	0	X	X
<u>Mirabel and Rodriguez</u> 1994	In 1994, a galactic speed record was obtained with the discovery of a superluminal source in our own galaxy, the cosmic X-ray source GRS1915+105. Several blobs were seen to expand in pairs within weeks by about 0.5 arc seconds.	0	0	0	X	X
Response	An unanswered challenge to the constant c of Special Relativity, coming from our own galactic neighborhood. No excuse here for the distortions caused by deep space. The relativity explanation is typical – <i>ad hoc</i> and contrived.	0	0	0	X	X
<u>Binary Star Precession</u> 1995	A key proof of General Relativity theory is the excess perihelion advance of Mercury. Each century, Mercury's orbit precesses 43 arcsec farther than Newton's equations predicted. Einstein's calculations, using General Relativity theory, accounted for the excess precession, matching the observations exactly. The effect was caused by Mercury's motion through the spacetime curved by the sun.	0	0	0	0	X
Response	General Relativity fails the precession test	0	0	0	0	X

Experiment	Type	G	H	E	S	R
	outside the solar system. It predicts precessions about double the measured precessions. General relativity can hardly be general, if it only predicts orbital precession in the solar system, but fails for binary stars. Even the solar system proofs for General Relativity have always been subject to controversy, searching for proof below the experimental signal-to-noise level. A slight asphericity in the sun's shape can cause the observed precession with only classical physics.					
<u>Aspden Effect</u> 1995	This experiment involved a gyroscope whose wheel was highly magnetic. The energy required to spin up to maximum speed was 1000 joules. For up to 60 seconds after the gyroscope stopped rotating, it would take ten times less energy to return it to the original velocity, only 100 joules. Aspden's gyroscopes would retain their hidden energy for a full 60 seconds. Ether energy flowing through a magnet is the Aspden effect.	0	0	✓	0	0
Response	Another experiment denied by modernists, connecting ether to rotation. Like a glass of water being stirred up with a spoon, the rotation of the gyroscope would cause the ether in the flywheel to spiral, to continue inside the wheel even when the gyroscope was stopped. The torsional ether energy is harnessed by the powerful magnetic flywheel. That there are frauds and charlatans involved in the ether/free energy enterprise is undeniable, but how does that differ from mainstream science?	0	0	✓	0	0
<u>Marinov Plasma Tube</u> 1996	A cylindrical magnet is cut along an axial plane and one half is turned upside-down (the magnetic forces themselves do the rotation). Around this magnet is a trough filled with mercury in which a copper ring floats. A current from the battery causes the ring to rotate. Working either as a motor or a generator, there is no opposing torque to the direction of rotation. While power is drawn from it, it will power itself.	0	0	✓	0	0

Experiment	Type	G	H	E	S	R
Response	Another experiment tapping into the torsional energy of the ether. What is lacking is an integration of all these ether/free energy results into a coherent ether model.	0	0	✓	0	0
<u>Casimir Effect</u> 1997	The attractive force between two surfaces in a vacuum was demonstrated by Hendrik Casimir over 50 years ago. Two mirrors facing each other in empty space are mutually attracted to each other by the vacuum electro-magnetic field. The Casimir effect is due to resonance of all-pervasive energy fields in the intervening space between objects. Since the Casimir force falls off rapidly with distance it is only measurable for small separations; it's the most famous mechanical effect of vacuum fluctuations.	0	0	✓	0	0
Response	The ether can account for the Casimir effect by recalling the shielding effect displayed in Michelson-Morley type experiments. Greater ether density outside the mirrors than inside would force them together – an ether-based Casimir force. No quantum vacuum is required, only the ether properties already discovered.	0	0	✓	0	0
<u>Magnetic Memory</u> 1997	Donald Roth discovered that, after first placing a fixed magnet close to a hanging magnet to attract it, then moving the magnet much farther away from the hanging magnet after five days, the magnet still attracted the hanging magnet the same way. This simulation of memory and amplification by ether is known to the Russians as “vacuum structuring.”	0	0	✓	0	0
Response	This shows another face of the ether – <ul style="list-style-type: none"> • a relationship with magnetism. • a retention of magnetic locations. • the ability to redirect ether flow. • the ability to intensify magnetic effects. • proof that magnetism is a movement of energy outside the magnet itself. 	0	0	✓	0	0

Experiment	Type	G	H	E	S	R
Wang Super-luminality 2000	Lijun Wang shocked the scientific community in 2000 with the results of a one-way speed of light test that measured propagation speeds of $310 c$ by supplementing and extending prior quantum tunneling experiments. Light pulses were accelerated to up to 300 times their normal velocity of 186,000 miles per second. In his test interpretation light will arrive at its destination almost before it has started, leaping forward in time and severely violating causality. Special Relativity's postulate of constant c is disproved, if the experiment is valid.	0	0	0	X	X
Response	Six years before, superluminal speeds were found in double galaxies. Now the same is found in terrestrial lab tests. This is one more step in the decline of Relativity and the ascent and restoration of Geocentrism.	0	0	0	X	X
Holger/Müller 2002	Promoted as the most precise experimental test to date of one of Special Relativity's central principles of c isotropy, the same value in every direction. This modern Michelson-Morley experiment using optical resonators found that Special Relativity theory passes with flying colors: c does not depend on its direction to within 1.7 parts in 10^{15} , a precision about three times better than the best previous experiment.	X	0	X	✓	0
Response	Miller's results, which suggested that in order to detect anisotropies in the speed of light, the interferometer needed to be surrounded by as little matter as possible, and located at a high altitude, were ignored in subsequent tests of the isotropy of the speed of light. Müller would have benefited greatly by recalling the experiment of Miller.	✓	X	✓	X	0
Quasars in galaxies 2003	One Big Bang tenet takes red shift proportional to distance, i.e., the larger the red shift, the farther the object must be. Another Big Bang belief is that red shift measures velocity, i.e., the larger the red shift, the faster it's receding from us.	0	0	0	0	0
Response	Galaxy NGC 7319 has an embedded quasar that is visually in front of it, but far	0	0	0	X	X

Experiment	Type	G	H	E	S	R
	behind it, according to the Big Bang's Hubble law. What are you going to believe, scientific speculation on the cause of red shifts or your own eyes?					
Redshift Survey Surprises 2004-2006	A redshift galaxy survey maps a sky section to measure the redshift of objects within the section. Applying Hubble's law to the redshifts allows conversion of the data to distances from Earth. Adding angular position data maps the 3D distribution and large-scale structure of the visible universe. The Great Wall, a huge complex of galaxies over 500 million light-years wide, dramatically illustrates what redshift surveys can detect.	0	X	0	0	0
Response	Not so dramatic, if the Hubble law's weaknesses are considered. Sloan shows hundreds of super clusters and "Great wall" structures. Huge clumps and dark voids stretch out along our line of sight from Earth; galaxies line up in filaments pointing at us – the "fingers of God". The simplest answer is to discard the Hubble formula and find a reliable distance indicator.	✓	X	0	0	0
<u>Gamma Ray Bursts 2006</u>	Gamma-Ray Bursts (GRB) are uniformly distributed across the sky, not along the Milky Way plane. They originate far outside of the Milky Way galaxy with enormous energies, detectable across the entire observable universe. Gamma Ray Bursts come from the hottest, fastest, densest, or most powerful objects ever seen. A burst will last anywhere from 0.01 to 1000 seconds, the brightest source in the gamma-ray sky, sometimes brighter than the whole gamma-ray sky! Gamma Ray Bursts occur randomly in time and sky direction. Gamma Ray Burst energy is channeled into narrow jets, detected only if aimed along our line of sight. The energy output is 10^{43} watts — 1,000 times brighter than quasars and one hundred quadrillion times more intense than the sun.	0	0	0	0	0
Response	The remote distances, if true, imply Earth	✓	X	0	0	X

Experiment	Type	G	H	E	S	R
	is the Gamma Ray Burst focus. GRB's are so intense they could easily be seen even deeper in space, but they are not seen. They mark the boundary of a finite universe. Hubble's law is used to place Gamma Ray Bursts in deep space, but their distance (and energy) are greatly overestimated. Arp's studies discredited the Hubble law: the Gamma Ray Bursts are not as far and energetic as first believed. No after glows are seen without seeing Gamma Ray Bursts first, implying GRBs are not focused in a beam.					
<u>Gravito-magnetic London Moment</u> 2006	Just as a charge in motion creates a magnetic field, so a moving mass generates a gravitomagnetic field. In Einstein's General Relativity, this effect is negligible. But this experiment finds otherwise – the effect is much larger than General Relativity expects.	0	0	0	0	X
Response	Two elements should grab our attention in modern experiments: magnetic fields and rotation. Past items in this chapter have shown that a torsional ether field produces anomalous effects when the two factors above are present. It is too early to venture a complete ether theory; more experimental conditions need to be explored. But this experiment will probably be one of the key tests in cracking the code of the ether.	0	0	✓	0	X
Polar ice caps	If the sun revolved around the Earth every 24 hours, it would melt the polar ice caps.	X	✓	0	0	0
Response	An argument heard from the newly or poorly instructed in physics. Apparently the geocentric model means the sun circles only the equator, oblivious to the fact that the geocentric model is what is seen from Earth! The angle made by the sun on Earth is the same in both models, independent of which is moving.	0	0	0	0	0

Stellar Aberration

Introduction to the concept:

A review of basic logic is required in anticipation of what is to come.

Consider a basic syllogism, where **C** is the **Cause** and **E** the **Effect**.

- (1) If C is true, then E is true
- (2) C is true
- (3) Then E is true

What if E is true?

If E, the effect, is true, no conclusion can be drawn about the cause. If one were to conclude that C is true because E is true, this would be the fallacy of cause-effect reversal. E could be true for other reasons than C. However, denial of the effect *does* imply the cause is not true. That is, if E is false, then C is false. This is valid reasoning.

The second preparation needed for the study of Stellar Aberration is a simple demonstration.

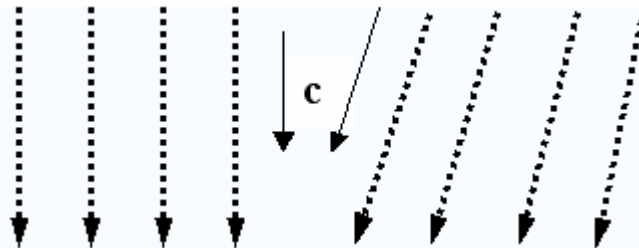

“c” is the rain drop speed, a model for the speed and direction of starlight rays for stellar aberration. We will model the light rays at speed c from a star as raindrops, first as falling vertically, then at a slant, as above.



A simple model of stellar aberration¹³⁴³

Consider an umbrella held in the rain to create a dry cylinder of air for the person holding the umbrella. When the man is standing, the umbrella is held vertically with no wind (above left), but otherwise tilted into the wind when he runs (above right). The umbrella must be tilted when the man is standing but the wind blows the rain at a slant (above right with man standing). Note that the umbrella is tilted to the right if the holder is standing and the wind is from the right, or the holder moves to the right with no wind. The tilting depends only on the relative motion of umbrella and rain.

To keep the person holding the umbrella dry in a vertical rainfall, he will do one of three things:

- (1) Hold the umbrella vertical.
- (2) If walking straight ahead, tilt the umbrella forward
- (3) If walking in a circle, keep the umbrella tilted forward - the top of the umbrella will also move in a circle.

To keep the person holding the umbrella dry during a slanted rainfall, he will do one of two things:

- (1) Hold the umbrella at the same slant as the rain.

¹³⁴³ <http://www.maths.abdn.ac.uk/dept/einstein/Bradley.jpg>

- (2) If the rain is falling like a tornado vortex, keep the umbrella tilted into the rain.

For the telescope and light rays (bottom, left and right), instead of an umbrella and rain, the same logical protocol applies.

Now for stellar aberration: In 1728, a physicist named James Bradley found that his chimney telescope showed aberration circles 20 arc-seconds in size. Every star's position consisted of these tiny annual loops, flat at the equator, largest at the poles. It was understood to be caused by the orbital motion of the Earth in the same way as vertically falling raindrops appear to fall diagonally when viewed by a man walking in a circle.

Stellar aberration of light (also *Bradley or astronomical aberration*) is an apparent motion of the stars describing elliptic orbits yearly, according to the latitude of the star. The star is never seen at its true position; it appears to be displaced onto an aberration ellipse. The aberration is measured in arc seconds ("), where one degree is 60 arc minutes (') and an arc minute is 60 arcsecs.

There are two other types of aberration, *diurnal* and *secular*, but only *annual aberration* is relevant here. Annual aberration is the component of stellar aberration resulting from the motion of the Earth about the sun.

The true path of light from a star is along the straight line from the star to the observer. However, because of the component of the observer's velocity in a direction perpendicular to the direction of the star, the light seems to be traveling at an angle to the true star direction. To observe a star, the central axis of a telescope must be tilted as much as 20.5" (seconds of arc) from the true star direction, depending on the star's direction compared to the direction of the Earth's supposed orbital motion. The orbital motion makes the stars appear to move in ellipses in the sky. All these have the same semi-major axis, 20.5" of arc, known as the constant of aberration. The tangent of the constant of aberration is equal to the ratio of the Earth's orbital speed to the speed of light.

$$\theta = \arctan(v/c) \sin(\text{latitude angle})$$

Bradley attributed the stellar aberration he observed as due to Earth's orbital velocity of 30 km/s relative to Newton's inertial space. He concluded that the experimental determination of the aberration constant gave the ratio of the velocities of light and of the Earth. Since the velocity of the Earth is known in the heliocentric model, the velocity of light can be found. At this time the speed of light was only estimated. The orbital velocity of the Earth is about 1/10,000 the speed of light, so the annual aberration of a star near the ecliptic is 1/10,000 of a radian toward the west (-20.5"), directly opposite to its apparent motion along the ecliptic. The aberration of light causes the positions of other stars off

the ecliptic to be displaced from their average position by less than $20.5''$. This discovery was motivated by the search for stellar parallax but totally unexpected.

Bradley found:

1. The major axis of any aberrational ellipse is always parallel to the ecliptic.
2. The major axis is equal to the ratio of the velocity of light to the velocity of the Earth.
3. The semi-major axis, the constant of aberration, is 20.4955 arc seconds.
4. The minor axis depends on the latitude, being the product of the major axis by the sine of the latitude.

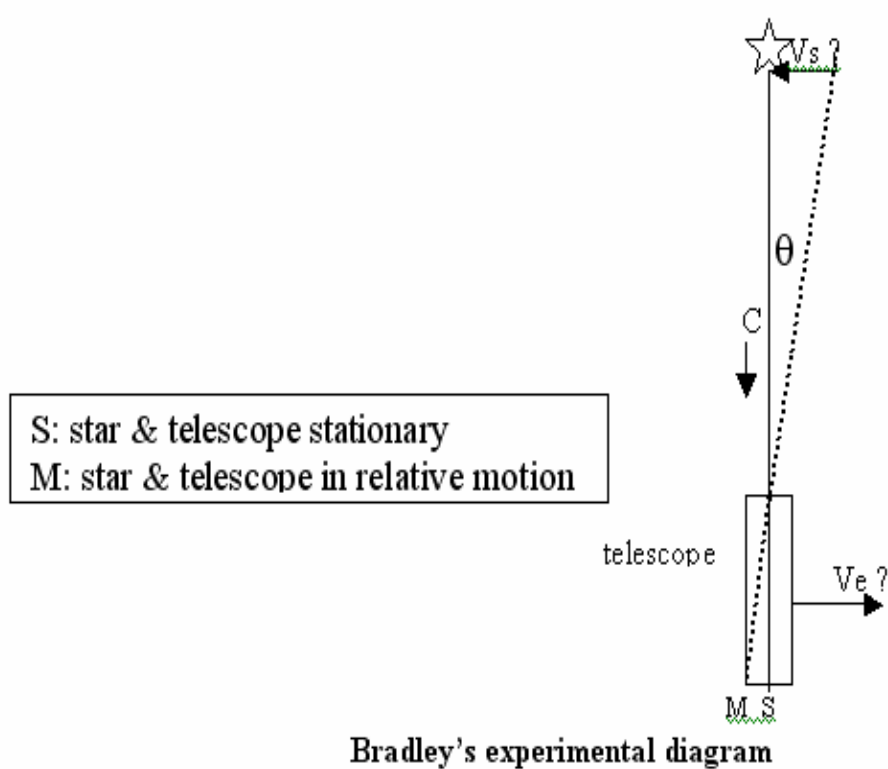

As seen above, aberration displacement from S to M could be due to:

- (1) the motion of the Earth ($V_e \neq 0$ and $V_s = 0$).
- (2) the motion of the star ($V_s \neq 0$ and $V_e = 0$).
- (3) a combination of both ($V_e \neq 0$; $V_s \neq 0$).

The reasoning of Bradley, a heliocentrist, was similar to the umbrella in the rain, except in this case, the umbrella (and its dry cylinder underneath) was the telescope and the rain was now the light ray from the star. Hence, Bradley reasoned:

1. If Earth moves in vertical starlight, the telescope will need to be tilted (if C then E).
2. The telescope does need tilting (E is true).
3. Thus, the Earth moves (C is true).

This is the fallacy of: “Effect implies cause”!

If the stars and their light were moving (like wind-blown rain), then the telescope would need to be tilted. Thus, there are at least two possible causes, not one. This fallacy is a modern cosmology favorite, along with misrepresentations of geocentric explanations.

Aberration models:

Neo-Tychonic view:

Stellar aberration is star motion centered on the sun as viewed from Earth, hence, there is no aberration in stellar motion as seen from the sun. The aberration is due to the apparent shift in the stellar positions that are centered on the sun. This is a parallax effect due to the change in position of a reference point.

The Tychonic view:

Posits that parallax, following Van der Kamp, is really stellar aberration. The objection to this view, however, is that parallax cannot be the cause of aberration because of the phase difference between the two optical effects. As such, the original Tychonic view would fail to explain aberration; the phase difference in the two phenomena rules out parallax.

Original Bradley model:

All stars had the same parallax, 20". Those at the ecliptic poles made circular orbits, and those near the ecliptic just oscillated back and forth, as expected. Were all the stars therefore at the same distance, about 10,000 radii of the Earth's orbit, which is about 1 light day away? Did he rediscover the roof of the firmament, to which the stars were attached, and behind which was heaven? No, the phase of the star's orbit was 90° behind the Earth's position in its orbit. To be parallax the positions should be 180° out of phase.

Nevertheless, Bradley's view is in contradiction to the modern view, known as *Relativistic Aberration*. In the Relativistic version, the apparent angular displacement of the observed position of a celestial object from its geometric position, caused by the finite velocity of light in combination with the relative motions of the observer *and of the observed object*. But in *Bradley Aberration*, the apparent angular displacement of the observed position of a celestial body results from the motion of the observer.

Relativity says the v to be used in the $v/c \times \sin(\text{lat})$ formula is the relative motion between star and Earth, which can be a substantial percent of c , according to red shift interpretations. But Bradley says the v must be in the heliocentric frame, so it is always 30 km/s.

Ironically, most astronomers believe these contradictory positions are both correct! The first is used to uphold Special Relativity; the second to disprove Geocentrism! The real fact is that both are wrong. The aberration is an intrinsic motion of the deep space firmament. Having a yearly period implies a connection to the ecliptic planar motion of the same period.

On telescope limits:

Point-like sources separated by an angle smaller than the angular resolution cannot be resolved. A single optical telescope has an angular resolution less than one arc-second, but Earth-based astronomical observations and atmospheric effects make attaining this very hard. The highest angular resolutions can be achieved by interferometry: the *Very Large Telescope Interferometer* is intended to achieve an effective angular resolution of 0.001 arc-seconds. Hubble's angular resolution is 0.05 arc-seconds.

Conflict with Relativity:

The theory of relativity says that events observed using light depend on the relative velocity between the source of light and the observer. At the time of the Bradley experiments, this principle was unknown. It would not be discussed until almost two centuries later, by Poincaré, and then formalized by Einstein in 1905. Bradley understood the measurements of the star Gamma Draconis as due to the proper velocity of the Earth around the sun. Earth's orbit around the sun made stars appear to be shifted in the direction of the Earth's motion. But again, both Bradley's interpretation is contrary to Special Relativity, but is rarely noted in modern articles attempting an aberration disproof of Geocentrism.

In modern physics, it is generally claimed that stellar aberration occurs when there is a relative motion between a source of light and an observer, so the motion of the Earth is not absolute, but relative. This

idea is based on Einstein's Relativity Principle, but it is not compatible with experimental observations. If relative motion of the stars is used in the Bradley formula, all the stars would be required to have a tangential velocity of 30 km/s, despite their radial distances varying from four light years to billions of light years. Geocentrists wait with eager anticipation how modern science is going to explain this anomaly.

Aberration and ether:

There are systematic differences in the fine details of the constant of aberration and in standard star positions as determined at different observatories, which might be explained by a variation in ether drift due to differences in the local coefficient of drag. The drag at any given station may depend upon altitude, local topology, man-made structures and the distribution of large land-masses, such as mountain ranges.

Bradley's results make perfect sense in an ether-filled universe. The effect could be caused by the ether flow or density variation between the star source and the Earth. The light speed changes while traversing the ether medium, bending according to the ether's properties and hitting the Earth at an angle, moving the image position of the star so as to form an annual ellipse. For example, stars on the equator have no observed North-South aberration component, so the ether flow in the space projected out from the equator has only an East-West flow.

Another valid interpretation is that the ether has no net effect on the starlight, but what is observed is, in fact, reality, the actual intrinsic elliptical motion of the stars. The only reason to discard this alternative is Occam's razor, which makes a subjective human judgment about the beauty and simplicity between two possible conclusions. Occam's razor sees complexity as an obstacle to human understanding, which it is, but excludes Revelation as a valid source of knowledge and is ignorant of God's perfect simplicity. Having no parts, God finds nothing complex. To Him all things are simple.

We take all of the aforementioned as a reasonable summary of the current status of the physics of aberration, except that we deny any kind of holistic or wholesale terrestrial motion and affirm the ether's motion around a stationary Earth.

Now we will answer the point-by-point contentions raised by modern cosmology's view of stellar aberration:

Claims and Responses:

Claim #1: Stellar aberration is due to the velocity of the Earth in its annual orbit about the sun, that is, the deflection of a celestial object toward the observer's motion due to Earth's velocity relative to inertial space. This experiment validates other proofs of the heliocentric model.

Response: Note here that the sun apparently defines the motion of “inertial” space, although this is not stated explicitly. The first sentence expresses the belief of Bradley and contradicts the relativity of motion claimed by Special Relativity by using “inertial space” as an absolute reference for the Earth’s orbital motion. Overall, heliocentrists offer no indisputable proof for their view. The allusion to geocentric disproofs is empty. Modern physics has only a few alleged disproofs, but postures as though there were many. The Galilean arguments for the phases of Venus, the moons of Jupiter and the tidal flows support both heliocentric and geocentric views, as already noted. The planetary motions measured by Brahe and interpreted by Kepler express a single possible model of the observed motions, without excluding the possibility that the Earth is not a planet (wanderer) in this system but a fixed location for observation. Newton’s belief in absolute space opposes the Special Relativity theory accepted by modern physics. Heliocentrism and Relativity will always be in metaphysical conflict, though this is rarely, if ever, acknowledged.

Claim #2: Bradley based his theory on the assertion that Earth’s speed is 30 km/s around the sun in order to derive the 20.5” arc aberration figure for each star. This required taking a third object, the sun, as fixed. But Einstein, in 1905, established that any point of reference can be used and the laws of physics will not be compromised.

Response: Therein is the conflict: the sun must be taken as at rest to derive the correct aberration angle, says Bradley. But Relativity says that such an assumption would make the sun an absolute reference object, which Einstein discounts. To be consistent with Special Relativity, only the relative velocity between the source star and the Earth can be employed. Moreover, this must include the radial component of the relative velocity. Why, then, do science textbooks still use Bradley’s derivation, which has been disproven for 100 years? Or is it Relativity that is in error, and the sun is at rest? How can the annual aberration of starlight still be based on an average speed of only 30 km/s with respect to the sun, when modern measurements like the Cosmic Microwave Background dipole show the whole solar system is moving at 400 km/s?

Claim #3: Bradley’s explanation of aberration disproves geocentrism.

Response: In actuality, Bradley’s explanation flagrantly violates Relativity theory:

- by ignoring the relative motion between source and observer, star and Earth.
- by making the sun the absolute frame of reference.

Ironically, the conflict between Bradley and Relativity has been conveniently classed as a non-issue by modern physicists, apparently by a gentleman's agreement that discrediting Geocentrism is more important than logical consistency. Observations of aberration are said to show that, in contradiction with Special Relativity, stellar aberration does not depend on the relative motion between the source and the detector but exists only when the detector is moving. Why do textbooks explain the results solely when the observer is moving?

Claim #4: Aberration depends only on the speed of the receiver/viewer.

Response: Then it is asymmetric, while relative motion is symmetric. What would explain the fact that, while the observational data on stellar aberration are compatible with a moving earth, the symmetric description, when the star (and not the observer) possesses the relative transverse motion, does not apparently lead to observations compatible with predictions?

Claim #5: Light aberration does not depend on the distance of stars, only on transverse velocity of detector/observer.

Response: It is then impossible to create a converse model, that is, where the Earth is immobile and stars are moving, as everyone on Earth perceives. Relativity says there should be such an alternative model. Why is this contradiction ignored?

Claim #6: Annual stellar aberration proves that light has a finite speed, and that the Earth is moving around the sun. This is inconsistent with a simple model of light in an ether which is dragged along by the Earth, because the ether and light would move along with the telescope. It is consistent with Special Relativity.

Response: Stellar aberration is cosmic motion centered on the earth – an intrinsic annual motion of all the stars produced by the firmament, superimposed on the higher order motions of diurnal rotation and yearly precession of the equinoxes. Scientifically, parallax cannot be the cause of aberration, because of the phase difference between the two optical effects. Scripturally, aberration cannot be caused by the Earth's motion because the Earth has no motion. The Bradley solution of $v/c \times \sin(lat)$ arbitrarily uses the alleged orbital speed of the Earth, implying the sun is at absolute rest. Then there should also be an additional smaller nightly component to stellar aberration due to the rotation speed, and a much larger component due to the motion of the solar system around the Milky Way, as detected by the Cosmic Microwave Background dipole, which contradicts the sun's lack of motion. So the Bradley formula is impotent.

Summary:

The *Bradley* formula for aberration angle is:

$$\theta = \arctan v_{t0}/c$$

where v_{t0} is the transverse velocity of the observer relative to the star. For the Earth, this is always its orbital velocity, +30 to -30 km/s.

In *Special Relativity* the formula is:

$$\theta = \gamma \arctan v_{tr}/c$$

where $\gamma = 1/(1 - v^2/c^2)^{1/2}$ and v_{tr} is the transverse velocity of the relative motion between source and observer.

The gamma term causes a third order change in the angle, which is already very small, of order v/c . It can safely be ignored in computations. The difference between the two equations is basically the reference frame for the velocity.

- For Bradley, the frame is fixed; it is always the sun – an absolute that is contrary to Relativity theory.
- For Special Relativity, the frame is relative to the source–observer motion.

So, if Special Relativity advocates are consistent, they should reject Bradley's theory. But then their main argument against Geocentrism would be nullified! What do the heliocentrists do? Judging from current practice, use whichever viewpoint fits the current discussion, and ignore the contradiction.

Diurnal aberration:

This is referred to in the literature as if it were an observed and established fact. But no clear documentation of its unambiguous measurement can be found. The measurement of small angles in astronomy, such as the maximum 0.3" for diurnal aberration when close to the horizontal plane, is difficult and tenuous because of the atmosphere and other influences. The accuracy of star and sun positions is $\sim 2''$ and all planet positions and the Moon are known to 10". So the measurement of the diurnal aberration has probably never been made, awash in the error of other unknown or uncompensated effects. Why, then, is it described in textbooks as being consistent with stellar aberration, which has been measured?

Binary stars:

The aberration of a binary star system would logically seem to vary as the faster star in orbit changes its direction compared to the Earth's velocity in relation to the sun. For binaries with a period of a few years or less, the Earth and the orbiting star are constantly changing their relative velocity, which should imply a corresponding variation in the aberration angle of the star viewed from Earth. But this is not so. Both stars exhibit the same aberration as if they were separate single stars.

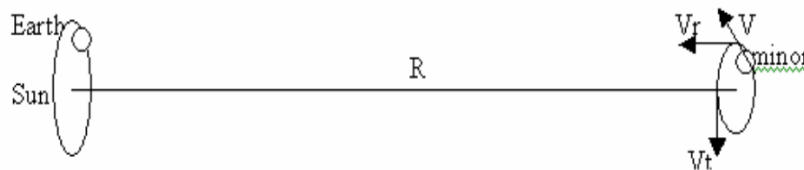
Binary stars anomaly**Heliocentric view of binary system:**

The radial motion V_r of the binary minor star above can be measured by its red shift. The maximum value of V_r is the same as the maximum value of V_t , the transverse velocity, when the minor star is moving perpendicular to the line of sight. The Doppler shifts of binary stars indicate their radial velocity, but this same velocity when tangential to the view from Earth does not produce the expected change from the normal stellar aberration. The predicted aberration for fast moving binary stars is never seen. Only the usual aberration of their center of mass motion is observed from Earth, the same value as for single star systems. The negative result contradicts the assumed dependence of aberration on relative motion. Logically, the claim that the Bradley aberration is due *only* to the relative motion between a source of light from a star and an observer on Earth is invalidated by the absence of aberration effects in binary star orbital motion.

Attempts to explain the absence of aberration in binary star motion using Special Relativity have not succeeded thus far. To the modern mind, this seems to eliminate all possibilities, as Geocentrism is not included in the running.

Binary Doppler Spectroscopy:

Claim: Stellar aberration depends on the relative velocity between source and observer, as Einstein maintained.

Response: Then each component of a spectroscopic binary star would have significantly different stellar aberration, contrary to observation,

which shows each component has the 20" aberration of a single star. Aberration of the individual star motion within the binary system would cause distortion of their observed elliptic orbits, but this does not happen. Only the Bradley aberration of their center of mass motion is observed from Earth.

Mathemagic:

Mathematics has often been abused and misused by Relativists. Advocates often obfuscate rather than illuminate by surrounding a Relativity theory application in obtuse mathematics. A fog of misunderstanding is cast over the Relativity interpretation rather than the light of knowledge for which mathematics was intended. It is instructive to see a case in point at a Web site intended to support Relativity theory with mathematics.¹³⁴⁴ In the section titled "Stellar Aberration," a formal proof is presented asserting that Relativity theory correctly predicts the binary star aberration as single stars. The relationship derived is not coordinate-invariant (covariant), so its results cannot be generalized for other boundary conditions. In other words, the result depends on the initial choice of time and space values. Only for the specific choice of conditions is the relationship true; any other choice leads to disproof of the Relativity theory aberration formula. The example is patently fallacious, as it employed unique initial conditions that resolved the problem only for that particular choice of boundary conditions, but predicted nonsense for any other choice. This mathematical equivalent to special pleading requires careful analysis to uncover its errors. It leads one to suspect that it was buried in equations to hide its flaws.

Ether:

Any motion of the ether or variation in its optical density between the star and the Earth would affect light waves traveling between them. Stellar aberration seemed to call for a completely fixed ether before the binary star anomaly was observed. The binary aberration anomaly could logically be an effect due to the local ether properties surrounding the binary system, in addition to, or in replacement of, the relative transverse velocity dependence.

As with the single star aberration, another valid interpretation is that the ether has no effect on the star light, but what is termed aberration is, in fact, observed reality, the actual elliptical motion of the stars – the Geocentric model.

Planetary aberration:

¹³⁴⁴ <http://www.mathpages.com/>

We will attempt to follow the logic of this type of aberration as presented by current scientific beliefs.

For the stars, the transit time is at least four years, so the time of flight correction is impossible to compute, thus travel time delay is ignored for stellar aberration. Under the assumption of a constant c (Special Relativity postulate #2), the transit delay within the solar system can be found if the distance is known (from independent reasoning). But the application of aberration theory to the planets leads to conflicting predictions, just as with the stellar case:

Bradley: Predicts the heliocentric speed of Earth of 30 km/s will produce a constant 20.5" aberration on any and all planets.

Special Relativity: predicts the varying relative speed between Earth and the observed planet will determine the aberration. For example, the relative speed between Earth and Mars will vary from 0 to 65 km/s, producing 0 to 43 arc seconds shift over the years. For both of the above, the transit time delay has the same geometry as the aberration diagram, so both cause the same angular change that lags behind the true position of the object.

Ephemeris computation: To calculate the aberration and transit delay, the actual position and speed of a planet must be known – the ephemeris. In lowest order, the parameters are given by Newton's/Kepler's laws. The knowledge of the exact motion to detect aberration effects requires knowing all the influences on the orbit, including perturbations by neighboring planets and moons. This reduces the precision to 0.1 arc minutes or 6 arc seconds. Telescopic accuracy is a few arc seconds, thus, the aberration should be seen. Planetary aberration for Mercury (assuming we knew an accurate ephemeris) would be different than aberration for Jupiter (assuming the same).

Interestingly enough, the determination of aberration within the solar system, not in deep space, is now said to be impossible, because no one really knows the real location of any planet. We only know their apparent positions, the direction they appear to be as we look at them. If we knew where they were – the actual position – we would know the deflection of aberration. If we knew that, we would know where they are. But we don't know either requirement, exactly, or exactly enough.

Unlike stellar aberration, planetary aberration has not been directly measured, but inferred in building some ephemeris, such as the almanac table. This is an interesting admission. If some ephemeris include aberration in their computations, then how can they be used in an experimental verification of the same aberration? As several astronomers have pointed out, the error produced in planet orbits by perturbations of other solar system objects, and even by their own moons, exceeds the aberration correction. This is a roundabout way of saying we really don't

know where the planets should be with enough accuracy to determine their aberration.

Here is the puzzle that results: the planets are much, much closer than the stars, and are subject to the well-tested gravity law of Newton. So how can we know exactly where the remote stars are, but not where Venus and Mars are, or should be? Is this another elephant in the living room? For the purposes of measuring aberration, how can we be so certain of the location of the stars, which are up to billions of light years away, but not the location of our solar system neighbors, mere light minutes away? Does that make sense?

Ephemeris only predicts the apparent positions of planets and is unconcerned with their actual locations. Let's reveal the implications. Many believe that NASA and the Jet Propulsion Laboratory make detailed flight plans based on their precise knowledge of celestial mechanics, but this is merely a modern myth. Spacecraft make numerous course adjustments during flight by dead reckoning in space and commands from ground stations.

Almanacs, such as Starpath, say they correct for planetary aberration, but what theory do they use? If Bradley is followed, they would use 30 km/s, the orbital speed of the detector. Then the correction would be the same for all planets, 20". This is clearly a measurable size, so this cannot be it. What of Relativity's appeal to the relative speed of the Earth-planet system? If so, then why was the Earth-star relative motion not put into use when calculating stellar aberration?

The topic of aberration is such a tangle that it deserves the careful attention of objective and logical analysts to establish what, in fact, is fact and what is fiction. We must be ready to accept that only the latter is true.

Moon aberration:

The relative speed of the Earth-moon pair would be the combined rotation speed of Earth and the orbital speed of the moon: only about .5 km/s – about .7 arc seconds of aberration angle, which is not really measurable. Yet the Earth-moon system together is said to be flying around the sun at 30 km/s, so that is the speed to use, when the moon is full or new. So the Bradley aberration angle is expected. Yet this is prior to 1980. Since then, the Cosmic Microwave Background dipole interpretation (and others) have determined the speed of the solar system is about 380 km/s, which is now the correct velocity to use (so we think)! But this speed will produce an aberration angle almost 13 times greater than the Bradley prediction: 4' 20". Double this to include the transit delay yields 8' 40", which is easily detectable.

Experiment:

When a Lunar Laser Ranging experiment is performed, a laser beam is first aimed at the moon toward retro-reflectors placed on its surface previously by astronauts. The retro-reflectors have an ingenious design, which always reflects the captured beam exactly back along the path of the incoming ray. If any light beam strikes the reflector surface, it will return on the same path; there's no deviation in direction, no correction angle. (See patent for a 'velocity-aberration correcting retroreflector satellite').¹³⁴⁵

During the time it takes this laser beam to travel to the moon and back (about 2.5 seconds round trip), both the Earth and moon (as part of the solar system) move about 948 km towards the Leo group (474 km while the beam is headed to the moon and 474 km while the beam is headed back to Earth). Since the retro-reflector sends light back to its point of origin, and because the returning beam is only 20 km wide when it returns, the returning laser beam should miss the telescope (that launched the laser beam) by at least 928 km (948 km minus 20 km). This is because both the Earth and moon have moved 948 km towards Leo while the laser beam was in flight. But, in fact, the laser beam is detected by the same telescope that sent the laser beam originally! Thus, the Earth's own moon does not experience aberration as the distant stars do. Why?

Satellite links: Technical background

The operations of GPS satellites and others have found that the aberration constant obeys Bradley's formula, if the relative speed of satellite and ground station is used for the transverse velocity. The 5.8" aberration observed is the same for ground-to-satellite laser signals, or the reverse, indicating that the roles are reversible and the speed of relative motion is the cause. At this point we can eliminate the sole dependence of aberration on the motion of the observer (Bradley's contention) or on the motion of the source stars alone. The velocity aberration angle of a satellite depends on the ratio between its relative transverse velocity and the laser beam velocity (or speed of light). The transverse velocities known today usually correspond to deviation angles in the range of approximately 1 to 10 arc seconds, or speeds of 1.5 to 15 km/s.

¹³⁴⁵ <http://www.freepatentsonline.com/5474264.html>

Satellite test of aberration:

Since aberration is independent of the distance between source and observer and the speed of the source, a laser beam calibrated on Earth to hit a target should exhibit an aberration angle when aboard an Earth satellite. According to NASA, near-Earth artificial satellites are usually computed in the geocentric system (ECEF) and do not require the usual correction for aberration in this system. Doesn't that imply that the geocentric system is inherently superior and preferable to the rotating Earth model for predicting the actual location of artificial satellites, and by extension, possibly also for all celestial motions? If not, why not?

Earth:

An experiment may prove that a light source on Earth has no aberration: a beam of light from a light source passes through very small holes in a number of plates standing in a row. The beam will be blocked 12 hours later if there is an aberration caused by the rotational velocity of the Earth. Of course, if the Earth is not spinning, there will be no aberration.

Fresnel ether drag:

Arago observed that the Earth always seems to be "at rest" in the ether. Fresnel used a drag factor to explain the difference between the absolute ether of Arago, unaffected by material motion, and a non-existent ether. This solution said that, in a moving transparent medium (water), the ether carrying the starlight is dragged along with the medium, like a boat in a river. The drag coefficient described how strongly a moving material medium "dragged" the ether. Fresnel drag is a change in the speed of light passing through a transparent moving medium, a change proportional to the refractive index and velocity of the medium. The drag factor of Fresnel is:

$$1 - 1/n^2$$

for a transparent medium of refractive index n . The speed of light in the medium n has an additional speed due to the ether dragged along with the medium:

$$c' = c/n + v(1 - 1/n^2)$$

In general, 19th century physicists were strongly convinced there was an absolute ether; the dragged ether was denied. The absolute ether was at rest while all cosmic objects moved through it. Only if the Earth is at rest in the absolute ether can light travel with equal speed in all directions (isotropically). If the Earth is moving in the absolute ether, the speed of light cannot be isotropic.

Wilhelm Veltmann, in the early 1870s, showed that the Fresnel coefficient must be applied individually to each frequency of light. That is, dispersion was present, a drag dependency on wavelength. Transparent bodies have to drag along different amounts of ether for different colors of light.

The Fresnel drag effect had empirical credibility - it is solidly established by experiments. By the start of the 20th century, Fresnel drag not only explained refraction but also reflection, diffraction, and interference experiments. What it lacks is a common sense interpretation for its underlying physical mechanism for partially coupling matter in motion with ether.

Fresnel drag needed to be appended to the immobile ether concept if this theory was to explain optical experiments to first order in v/c and the Earth were to be at rest in this immobile ether. But many physicists were unhappy that the ether was so little affected by matter. The focus from this time to the present (where the Cosmic Microwave Background is the present reference for immobility) was obviously on a stationary ether, not an immobile Earth. The immobile Earth had been discarded as an option historically, but erroneously, as we have seen so far based on Bradley aberration. Faced with a disproof of heliocentrism and confirmation of geocentrism, scientists desperately strove to find an escape path. At this time in history, the only known way of reconciling stellar aberration with wave theory was Fresnel's partial dragging. This *ad hoc* remedy gave heliocentrism a temporary reprieve, but still the question of geocentrism or heliocentrism was not resolved. The logical conclusion left at this point was: either geocentrism or heliocentrism is possible, if ether drag exists.

Claim: An objection raised against Fresnel's ether drag model is the apparent distinction between two kinds of ether, a universal kind unaffected by matter, as though impervious to this type, and a second kind carried along by transparent media.

Response: But a dual ether (or a fluid ether and a rigid plenum, more accurately) is just the conclusion drawn from the Genesis exegesis of Day 1 and Day 4 and modern experiments.

Stokes:

In 1845, Stokes attempted to account for stellar aberration on the basis of a moving Earth dragging along ether in its vicinity, in addition to the consideration of how the wave fronts of stellar light change direction when encountering the Earth's 'ethersphere.' The light ray really is deflected during its passage through the ether, not apparently. Stokes needed an alternate account of aberration because he disbelieved the hypothesis of an immobile ether.

Fresnel realized that polarization could be explained easily in the wave theory if light consists of transverse rather longitudinal waves, such as sound. To support the transverse mode, ether needed enough stiffness to supply the transverse forces opposing the distortions produced by the waves. The ether, if it simulated a mechanical system, had to be a solid. This picture of the ether conflicts with an immobile ether unaffected by the motion of matter. It was more intuitive to assume that matter was the cause of the ether drag. Stokes became the champion of this view by proposing a "Silly Putty" model of the ether. Ether behaves as a rigid solid for the high frequencies of light and as a fluid for the slower motion of celestial bodies traversing it. At the Earth's surface, the ether will be stationary with respect to it. This more realistic model of the ether was a more complicated explanation of aberration.

Stokes differed from Fresnel's partial drag theory. He interpreted stellar aberration as an ether that was totally, not partially, dragged along next to the Earth. The wave fronts of starlight change direction after entering the Earth's ethersphere. Stokes' ether was an incompressible (implies c is constant) and irrotational fluid with no viscosity to produce drag. The velocity of the ether and an object matched at the object's boundary. Incoming plane waves were tilted by the ether flow by the same amount as stellar aberration. Lorentz found that Stokes' assumptions self-conflicted, because the velocity of a potential flow past a sphere does not match the sphere's speed at the boundary. Stokes had assumed the ether flow relative to the Earth was zero at the Earth's surface; the aberration angle θ is given by:

$$\sin(\theta) = \sin(\delta) |V_s|/c$$

where δ is the declination of the star and V_s its velocity, as observed. The flow velocity is parallel to the surface, but it is non-zero, and can vary widely. Changing Stokes' assumptions, such as making the ether compressible to achieve zero surface velocity, introduces effects that predict a different aberration angle. Conclusion: Stokes' theory of a completely dragged ether was unsuccessful.

Faraday rotor generator (1831):

A homopolar generator/Faraday disc consists of a conducting flywheel rotating with constant angular velocity ω in a constant magnetic field \mathbf{B} perpendicular to the plane of the disc. A conducting frame makes conducting contacts with the center and a point on the periphery of the disc. Three tests are performed:

Test #	Copper disc	Magnet	Current ?
1	rotates	fixed	Yes
2	fixed	rotates	No!
3	rotate together	rotate together	Yes!

Faraday's classic law of electromagnetic induction states that it is the relative motion of the circuit and the magnet that generates a current. According to this view, test 1 and 2 should produce a current and test 3 should produce none.

Lorentz Force:

All free electrons in the conduction band of the copper disc that move through a magnetic field experience a Lorentz force of $\mathbf{F} = q\mathbf{v} \times \mathbf{B}$, where \mathbf{v} is the velocity of the electrons. This force is perpendicular to both the velocity of the electrons, which is tangential, and the magnetic flux, which is normal to the disc, and is therefore radial. The conduction band electrons, then, move radially and create a current if the circuit is complete through the slip rings.

When the disk spins without an external return path, electrons collect along the rim and leave a deficit + charge near the axis. The charge separation is proportional to the magnetic field and the rotational velocity of the disk, but independent of any rotation of the magnet. The amount of polarization is determined by the absolute rotation of the disk relative to an inertial frame. The relative rotation of the disk and the magnet plays no role.

Claims and Responses:

Claim #1: If the magnetic field is provided by a permanent magnet, the generator works regardless of whether the magnet is fixed to the stator or rotates with the disc, the Faraday paradox.

Response: But as usual, the question is: "velocity relative to what?" If the velocity relative to the magnet is assumed as the cause of the Lorentz force, then the explanation contradicts Special Relativity, in which it is impossible to tell whether a uniform magnetic field is moving or stationary. This assumption would also imply that rotating the magnet

and not the disc would cause a current to flow, which is not what has been observed.

Claim #2: The correct interpretation of the *velocity* of the electron is that it is relative to the apparatus parts, the sliding contacts and the external circuit. These laboratory objects act as the inanimate observer in Special Relativity. The velocity of the electrons in the lab frame must be used for congruence between theory and reality.

Response: But the lab frame is none other than the geocentric frame!

Claim #3: Faraday discovered that the magnet and disc could be cemented together and rotated conjointly, if the magnet were the same shape as the disc. The same voltage was measured with sliding contacts that touched the center and edge of the conducting disc, as when the magnet was fixed and the disc rotated alone. Was relative motion unnecessary for the generation of electricity?

Response: Note that when the copper and magnetic discs are cemented together, they both move relative to the Earth – the geocentric frame.

Claim #4: After many years, Faraday concluded that when a magnet is rotated, its magnetic field remains stationary.

Response: Stationary with respect to what? If it is the Earth or laboratory frame, then this confirms the geocentric theory! If the Earth were really rotating, all the metals in it would be generating induced electromotive forces as they passed through the Earth's own static magnetic field. And induced currents would be created wherever a complete circuit exists. But where are all these self-induced effects, which should be seen if the Earth rotates?

Parallax (1838):

Flush with the discovery of a great advance in technology (the lever!) Archimedes was emboldened to say:

*Give me a lever long enough, and a prop strong enough,
and I can singlehandedly move the world.*

This aphorism has at least two shortcomings:

1. It boasts that the world can be moved, in direct conflict with the Scriptures: Psalm 104:5: *He set the earth on its foundations; it can never be moved.*
2. His logic also failed, in that he assumes he would have an immovable place to stand, to operate the lever.

Those who propose stellar parallax as a proof of heliocentrism and a disproof of geocentrism make the same false assumption.

Parallax can be demonstrated by placing your index finger in front of your nose and then alternately closing each eye. Either the finger or the background will seem to move, depending on your focus. But, of course, there is no real motion, only a shift in viewpoint relative to a reference point or line – your finger. This is a simple example of parallax, the shift in position of an object due to motion relative to a fixed reference line. We shall see that the whole crux of the parallax disproof of geocentrism hinges on knowing what line is truly fixed. The knowledge of what is the actual motion is impossible without a known fixed point.

In 1838, astronomical instruments were precise enough for Bessel to first measure a parallax angle for a nearby star after six months of observation. He was the first to use parallax in calculating the distance to a star. Parallax would provide the first accurate measurement of interstellar distances, implying that 61 Cygni had a parallax of 0.314 arcseconds, which, given the diameter of the Earth's orbit, indicated that the star was ~3 parsecs or 10 light years away. His interpretive heliocentric diagram is shown below. It is always shown in science books as proof of the sun's centrality. And so it is, if, in beginning the analysis, one assumes that the sun is the fixed reference point. But this is the fallacy of *petitio principii* (begging the question) or assuming true what has yet to be proven. Measurements of parallax by a viewer from the sun would show none, according to modern science.

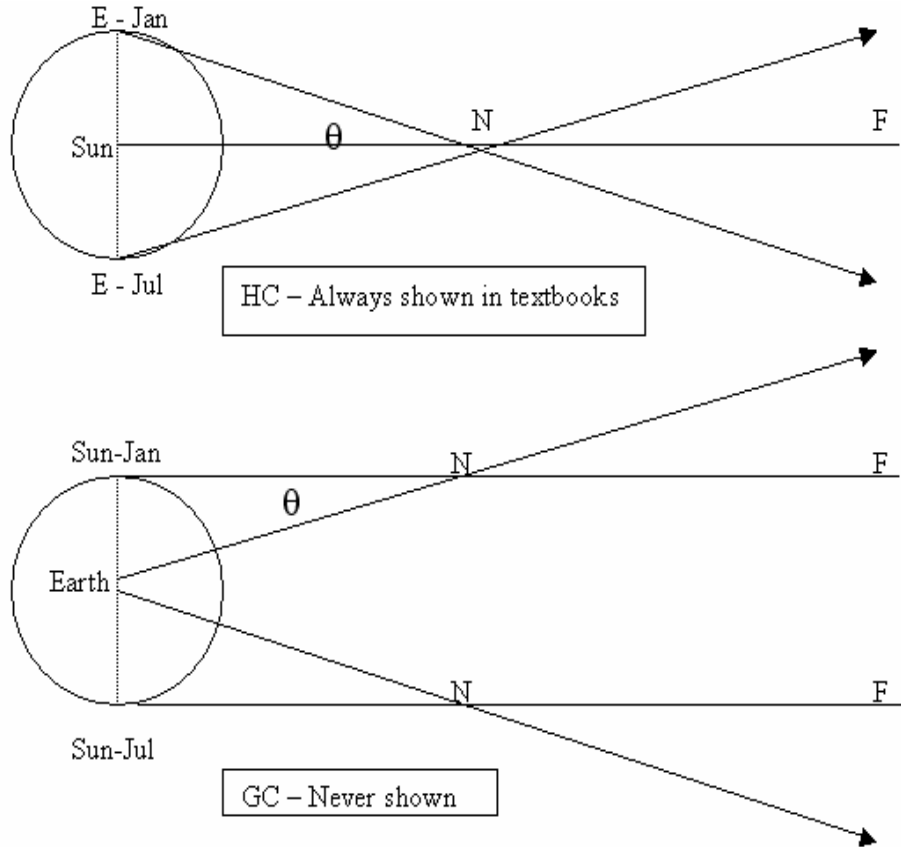

Top: Heliocentric view of parallax
Bottom: Geocentric view of parallax

The bottom diagram is a classic original, never shown in mainline science books, never even discussed as a possibility. So your eyes are two of only a few that have seen it - an equally valid alternative to the heliocentric diagram, including the size of the parallax angle, with the (a) sun (b) near star (c) far star alignment the same in both views.

In the diagram below, we sight along a near (N) star at a far (F) star from Earth (E) and see F move up. What is the inference?

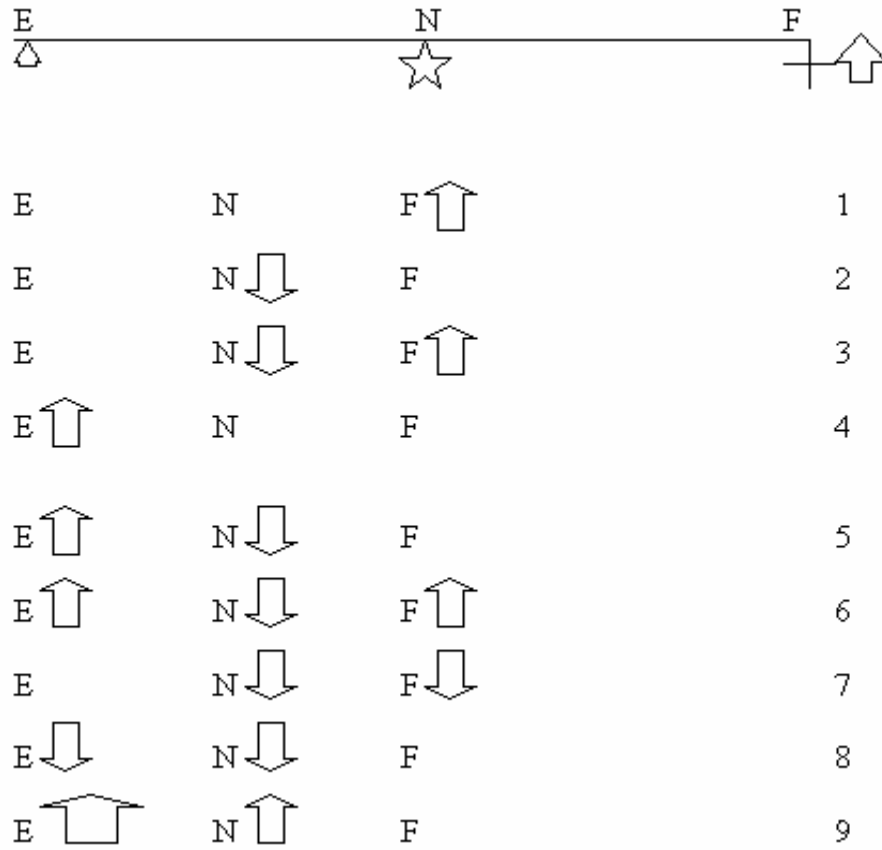

From Earth, any of these 9 rows of different object motions above will look like the Far star moved up, including row 7, where F actually moves down when N does likewise. It is clear from this chart that the true state of motion critically depends on knowing what is fixed, the fiducial reference. The apparent shift in parallax can only be real if the fixed point is known independently. In the case of the Earth, the independent source affirming it is fixed is biblical Revelation. The same source affirms that the sun moves.

Arago:

In 1810 Arago attempted to measure the extent to which photons would be refracted by a glass prism at the front of a telescope. He anticipated that there would be different angles of refraction due to the different velocities of the stars and the motion of the Earth at different times of the day and year. Contrary to this expectation, he found no difference in refraction between stars, between times of day or between seasons, only ordinary stellar aberration.

He also considered the refraction of light from the same star over the course of a year. Changes in the orbital velocity of the earth with respect to the star would presumably produce changes in the relative

velocity of the Earth and the starlight. Arago observed no such effect on the refraction of the starlight.

Claim: Arago viewed stellar aberration through a normal lens and through a thick prism with a very different index of refraction. Again, he found no difference. Both experiments imply that the speed of light is independent of the motion of the source.

Response: They both also allow that the observer on Earth has no motion.

Fully dragged ether:

The experiments demonstrated that Earth's movement does not influence optics near the surface. One implication is that the ether is immovable with respect to the Earth (the total ether drag hypothesis). Together star aberration and Arago's experiments show that:

- the ether dragging caused by the Earth is relative only to the Earth but not the whole solar system.
- the range of the dragged ether must be small
- the ether has a pressure/density gradient.
- c is anisotropic.
- every cosmic body could have an ether lens that distorts light paths, as in General Relativity.

With regard to the last point, all we have is proof of the ether effect on Earth. Extending this result to other cosmic bodies is speculation, not science. In 1818, Fresnel added the drag coefficient to the immobile ether hypothesis to account for Arago's result.

A telescope set up on Earth can be focused on a star that is in the direction the Earth is traveling. Two of the light beams from the star are focused at a point P within the telescope. Since the telescope and observer are moving with a velocity of 30 km/s, the observer's eyes will arrive at point P at the same time as the light beams, and the observer will see the star in focus. But 6 months later, with the same focus, the situation will be entirely different, since the Earth will be on the other side of its orbit. Now the telescope will be traveling away from the star with the same velocity. It was predicted that the observer's eye will no longer be at point P when the light beams arrive there – the star will be out of focus. A telescope that was originally in focus on a distant star should be out of focus six months later. Scientists did not measure the expected out-of-focus effect. This Arago *out of focus effect* has never been found. Besides a full dragged ether explanation, the geocentric theory of a motionless Earth also fits.

Fizeau:

Experiment description: In 1851, Fizeau devised an experiment to measure Fresnel's drag factor. The Fizeau optical interferometer was devised to measure very small differences in time or distance. The drag coefficient of Fresnel:

$$f = 1 - 1/n^2$$

corresponds to a fringe shift of :

$$\delta = 4n^2fvL/(\lambda c)$$

λ being the wavelength of the light, v the flow speed of the water and L the path length. Fizeau recorded a shift of $\delta = 0.23$ interference lines implying an empirical drag factor of $f = 0.48$. From $f = 1 - 1/n^2$, $f = 0.43$. Within a 10% error, Fizeau confirmed Fresnel's drag factor.

Special Relativity predicts no ether but does predict that c in a moving medium differs from the speed in the rest medium, consistent with the Fresnel drag coefficient. Fizeau's experiment found that the velocity of light in a liquid is smaller than that in vacuum, depending on how dense the liquid is.

Fizeau theory:

Fizeau used interferometry to determine how the speed of a moving liquid affects the speed of light. Light travels in a motionless liquid with a velocity w with respect to the liquid. According to Special Relativity, this speed does not depend on the liquid's motion relative to the tube T. The liquid then moves with a velocity v relative to the tube.

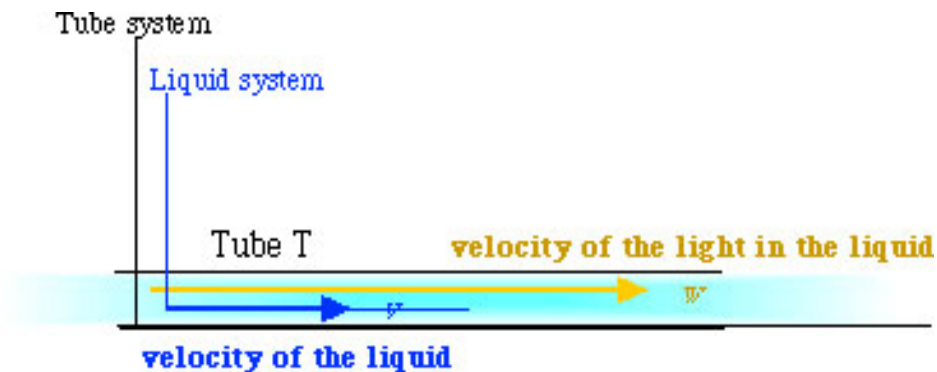
**Theoretical analysis of Fizeau experiment¹³⁴⁶**

¹³⁴⁶ Copyright © Soshichi Uchii

In a transparent fluid at rest, the phase velocity of light, $w = c/n$, is isotropic and inversely proportional to the fluid's index of refraction, n . If c is parallel to the velocity of the fluid v , then w is the *observed* speed of light in the moving fluid. According to Special Relativity's rule for addition of velocities, we have:

$$w = (u + v) / (1 + uv/c^2)$$

$$\approx c/n + vf$$

The coefficient $f = (1 - 1/n^2)$ is known as the Fresnel drag coefficient. As such, f will be 0 if the motion of the liquid had no influence on c . It will be 1 if light was entirely "carried" by the liquid, as sound is. What is actually observed is *partial* dragging. Although Fizeau's relation can be derived without resorting to the principle of relativity (Lorentz did so), Einstein considered it an excellent experimental test of Special Relativity. Unfortunately, the denial of multiple causes for observed results (except, of course, for Special Relativity's interpretation) is one of the key factors in current scientific rhetoric.

Hoek 1868:

In 1868, Hoek tried to detect the Earth's absolute orbital speed and improved on the accuracy of the Arago experiment. The experiment was similar to Fizeau's, but simpler in concept and easier to explain in the absence of ether.

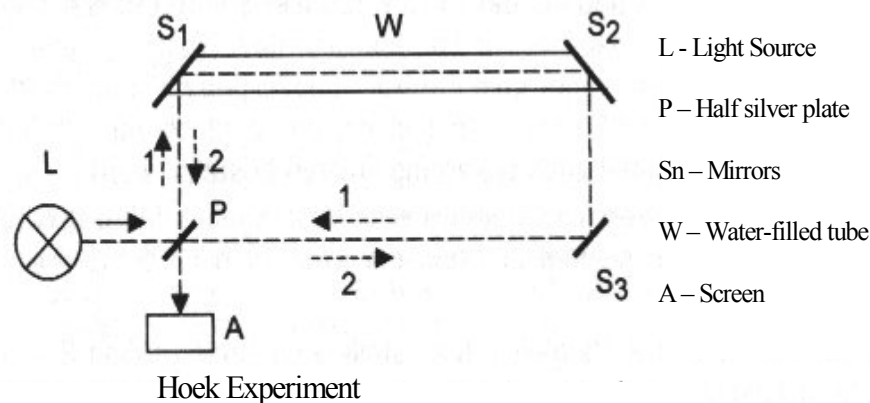

As shown in the figure above, the Hoek interferometer sent light opposite ways around a closed path, the top part of which included a tube filled with water, which was expected to partially drag the ether. By rotating the apparatus through various angles, and observing the manner in which the interference patterns shift, one can

determine the degree to which the ether is constrained by the water due to the motion of the Earth in its orbit.

The fringe pattern did not change at all for any orientation. Each of the rays took the same time to traverse the square circuit. If c is light's speed in air, c_1 the speed in water, n the index of refraction $= c/c_1$, ϕ is the Fresnel drag coefficient, d the distance S_1S_2 or S_2S_3 , time is distance/speed and v is the water speed:

$$d/(c_1 + \phi - v) + d/(c + v) = d/(c_1 - \phi + v) + d/(c - v)$$

Solving for ϕ to first order in v/c yields Fresnel's relation:

$$\phi = (1 - 1/n^2)v$$

Hoek's analysis assumed partial drag of ether. The setup size and time of observation are small, so the Earth's orbital motion is virtually linear and inertial during the experiment. In the experiment's rest frame, no fringe shift is expected, even if the device is rotated. But the orbital speed of 30 km/s should perceptibly drag the ether with the water. If there is no ether to drag, $\phi = 0$, and the etherless solution is obtained, consistent with Special Relativity.

So strong was (and still is) the bias against an immobile Earth that the obvious interpretation of the result is not:

$$\phi = 0 \text{ (zero)}$$

but

$$v = 0 \geq \phi = (1 - 1/n^2)v = 0$$

where $v = 0$ because the Earth's "orbital" speed is 0 (zero)!

Airy 1871:

George Airy, 150 years after the Bradley aberration measurements, built a water-telescope to prove the ether theory and measure absolute motion for the Earth. His expectation was to get some change in the effect of astronomical aberration, since water seemed to partially drag/transport a light beam in Fizeau's experiment. Did aberration occur inside the telescope? Did the ether-drag in water change the aberration angle? If c is less in water than air, would aberration in an air-filled telescope be different than in a water-filled telescope? Would refraction of starlight from air to water be different than normal aberration predicted?

None of these things occurred, and a null result meant that aberration was the same for air and water media. This null result is usually explained as ether-drag effects caused by the water. But the experiment showed that the light was deflected by ether *before* entering the telescope! Otherwise, it shows that there is no shift in light and the sources are moving in aberrant ellipses!

In actuality, if the Earth was actually moving, the beam should deflect more; if the starlight were moving, there should be no change. Water slowed down the speed of the light inside the telescope, yet Airy found no need to change the telescope angle.

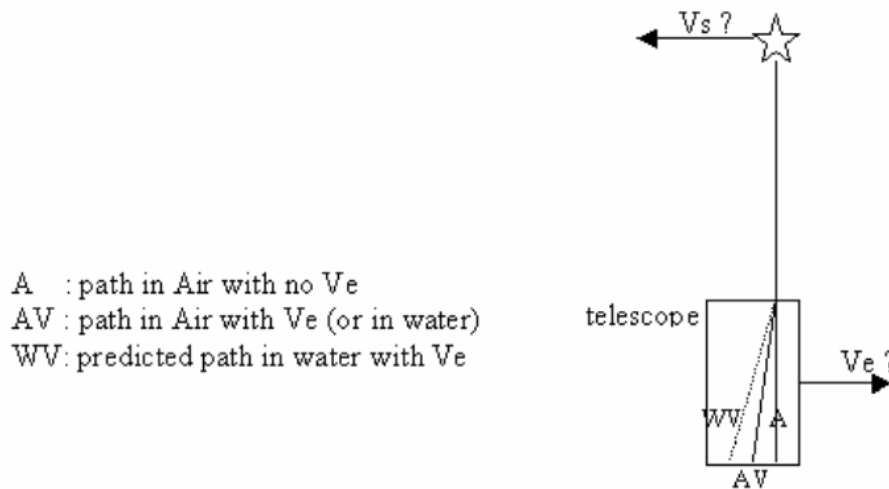

In this sideview of the water telescope, the new path of the aberrated starlight should be WV ; the result was actually AV , the same as the air telescope. Think of the telescope like an empty pipe, tilted so that starlight hits the center of the bottom edge. Adding water will only slow the light down, not change its direction. If the pipe is actually moving while the beam is inside the pipe, slowing down the beam would necessitate tilting the pipe to hit the center bottom edge. Obviously, the starlight was already coming in at the aberration angle, since the water's refraction had no effect. In effect the water's high refractive index made visible the smaller Fresnel drag of the ether, showing there was no drag of ether or water due to telescope motion. This inferred that the stars were moving relative to a stationary Earth, not that the Earth was moving relative to the 'fixed' stars. When starlight slows down in the water, it still hits the telescope bottom at the same place as in air because its deflection occurred prior to its entry into the telescope. If the telescope were really moving, it would move further sideways while the slower light is inside the telescope, causing a greater deflection than with air.

Science claims to be logical and rational, while religion is not. The following syllogism demonstrates what the Airy experiment logically concludes.

- (a) If the Earth moves, the water telescope will need additional tilting
- (b) But the water telescope does not need tilting! (effect is false)
- (c) Thus, Earth does not move! (so, cause is false)

This is valid logic: if the effect is not present, neither can the cause be present. For if the cause were present, so would the effect. But supporting the geocentric model is unacceptable to the prevailing modernist ideology. In fact, this experiment was called “Airy’s failure,” because it contradicted the heliocentric metaphysics. The term “Airy’s failure” gives psychological insight to the thoughts of the experimenters during this era. Earth motion with respect to ether was universally expected as the only outcome. Both this experiment and the Michelson–Morley experiment were thought to be dead-ends to understanding reality until Einstein rescued physical theory by ignoring the evidence for Geocentrism and ether, opting instead for Special Relativity, which gave a mathematical solution at the expense of logic.

Summary:

Looking at stars, if the Earth is moving, or if the star is moving and the Earth is at rest, the relative motion of the telescope and the light traveling down the telescope would be sideways relative to the telescope. The telescope must be tilted to keep the light from hitting the side. This is familiar to astronomers. It is commonly called *aberration*. When the water-filled telescope reduces c to 77% of c , only motion of the Earth, not the star, should affect the amount of additional tilt required on the telescope. Airy thought he needed to tilt his water-filled telescope more than the air-filled telescope to see a star. He did not. The starlight was already coming in at the correct angle, so no change was needed. This demonstrated that it was the stars moving relative to a stationary earth and not the fast orbiting Earth moving relative to the comparatively stationary stars. If the telescope were moving, he would have had to change the angle. If the water-filled telescope had to be tilted more than the empty telescope to see the star, it would mean that the Earth was moving (around the sun).

Conclusion: Aberration is independent of the local medium. In fact, Airy’s failure was a [unrecognized] geocentric success; the results were consistent with an immobile Earth.

Michelson-Morley 1887:

The Michelson-Morley experiment is a landmark event in the history of physics. A stationary ether had been proposed to support the transmission of light through space. The experiment was intended to verify the motion of the Earth around the sun through the static ether. But it was said to have failed to do so, since the speed of light apparently did not depend on the reference frame in which it was measured.

The interpretation of the results are still actively being discussed, over a century after the fact. And the results of similar experiments since then have led reasonable people to ask of the null result, “But, just how null is null?”

The Michelson-Morley experiment null result was rather astounding and not explainable by the then-current theory of wave propagation in a static ether. Efforts to save the ether theory included ether-drag or entrainment, which would reduce the expected effect from a rigid ether. The Earth’s gravitational field dragged the ether around with it in such a way to eliminate the ether’s effect.

Another attempt was the Lorentz-Fitzgerald contraction hypothesis, which claimed that everything contracted in the direction of travel through the ether, without providing any explanatory mechanism or independent empirical proof. It was thought that Michelson-Morley obtained a null result due to this contraction, which neutralized the ether’s effect on light. However, the Kennedy-Thorndike experiment in 1932 eliminated Lorentz-Fitzgerald contraction as a viable option.

The interpretation that the medium drags/entrains the ether with only a part of the medium’s velocity was questioned after Wilhelm Veltmann demonstrated that the refractive index, n , in Fresnel’s formula depended upon the wavelength of light. The ether could not be moving at a speed that depended on wavelength – a dispersive property – if it was required that ether have no dispersion, as some did. In any case, the idea of a simple rigid ether was dealt a serious blow. However, positive results for the presence of ether in various theoretical forms were claimed by Dayton Miller, Sagnac in 1913, and Michelson and Gale in 1925.

A simple model:

The simplified Michelson-Morley experiment test procedure was equivalent to putting your hand in the water to test for motion of a boat. If the boat is moving through still water, or if there is a current outside a boat tied up at a dock, you will feel the water flow. If the speed of the boat is v_b in a lake, then in a river with current v_r the boat’s speed will increase by v_r headed downstream and increase by v_r headed upstream:

$$V_{\text{up}} = v_r - v_b$$

$$V_{\text{down}} = v_r + v_b$$

This is the Galilean velocity transformation of simple addition/subtraction of relative velocities. Heading directly across the river will cause the boat's actual motion to drift downstream, due to the push of the water flow. Using this boat-water model, Michelson and Morley sought to measure the difference in length (and time) in the analogous motion of light (the boat) through different directions of the ether wind (water current). As they understood it, with the apparatus fixed to the Earth as it orbits the sun, the direction of the equipment would change direction through the ether every six months.

Description:

Shielding of the apparatus by this interior location and a short light-path diminished the effect of the ether, as Dayton Miller showed. A small but practically “null” result was virtually guaranteed by using this experiment protocol. The apparatus was located in a closed room in the basement of a stone building, isolated from thermal and vibrational effects. Building the apparatus on top of a huge block of marble, floating in a pool of mercury, reduced vibrations further. The sensitivity was about 1/100th (0.01) of a fringe. Each full rotation of the device in the mercury pool made each arm parallel to the ether wind twice and perpendicular twice, yielding a sine wave output. If the wind were solely from the Earth's solar orbit, the wind would fully change E-W directions during a 12-hour period. The yearly cycles would be seen as a change in wind speed.

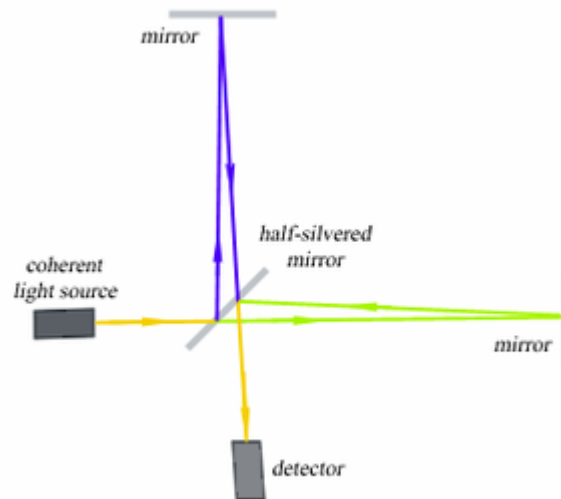

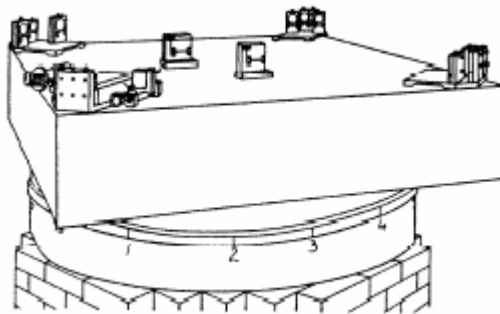
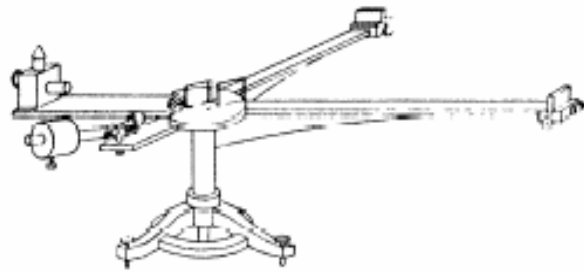
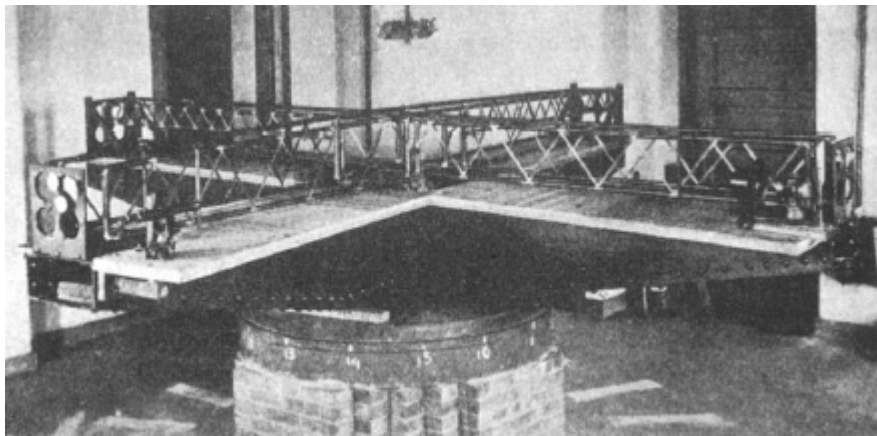
Interferometer schematic¹³⁴⁷**Interferometer layout**¹³⁴⁸

¹³⁴⁷ <http://upload.wikimedia.org/wikipedia/en/thumb/d/d7/Interferometer.png/300px-Interferometer.png> (Licensed under GNU 1.2)

¹³⁴⁸ The Ether-Drift Experiments and the Determination of the Absolute Motion of the Earth, Dayton Miller, (Reviews of Modern Physics 5, 203-242 (1933))

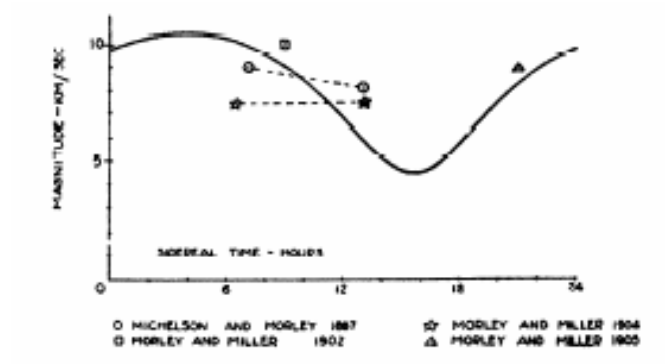
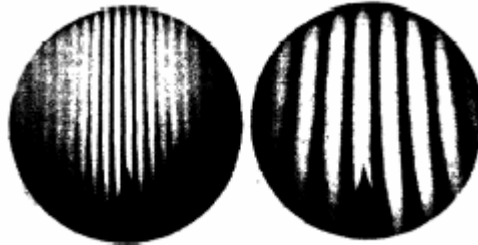
Michelson interferometer¹³⁴⁹Comparison of ether drift velocity: Michelson/Morley/Miller¹³⁵⁰Interference fringes as seen in the interferometer¹³⁵¹

¹³⁴⁹ The Ether-Drift Experiments and the Determination of the Absolute Motion of the Earth, Dayton Miller, (Reviews of Modern Physics 5, 203-242 (1933))

¹³⁵⁰ The Ether-Drift Experiments and the Determination of the Absolute Motion of the Earth, Dayton Miller, (Reviews of Modern Physics 5, 203-242 (1933))

¹³⁵¹ The Ether-Drift Experiments and the Determination of the Absolute Motion of the Earth, Dayton Miller, (Reviews of Modern Physics 5, 203-242 (1933))



Open air experiment at Mt. Wilson¹³⁵²

A light beam is directed at an angle of 45 degrees at a half-silvered, half transparent mirror *A*. The split beams reflect off mirrors *C*, *D* back to the half-silvered mirror, are merged at *A* so a telescope at *O* views the 2 overlapping quarter-intensity beams together. If there really is an ether wind affecting the light, the overlapping beams should arrive at slightly different times, since their path lengths are different. One path was up and down the ether stream, the other across it. Rotating the whole apparatus in various directions on a turntable would find the maximum effect, corresponding to being aligned with the ether stream. This would also eliminate systematic errors in the path lengths.

The interferometer can be calibrated by moving mirror *D* a small distance *d*. The change in distance can then be measured by counting *m*, the number of bright fringes in the intensity pattern. The difference in path length is $2d$ and the wavelength of the monochromatic light is λ . For the maximum fringe signal detected,

$$2d = m\lambda$$

The optical path length between the mirrors also depends on the refractive index *n* along the path. If *n* and *p* are the atmospheric index of refraction and pressure and Δp the change in pressure along the path from the initial pressure to its current value:

$$m = (n - 1) \times (2 d/\lambda) \cdot (\Delta p/p)$$

so

$$2d = m\lambda p \Delta p / (n - 1)$$

¹³⁵² The Ether-Drift Experiments and the Determination of the Absolute Motion of the Earth, Dayton Miller, (Reviews of Modern Physics 5, 203-242 (1933))

For gases with indices of refraction very close to one, the denominator will be very small, and the fraction very large. This refractive correction was not used by Michelson-Morley and wasn't even realized until a few years ago (see Cahill). The small fringe shift measured must be multiplied by the large refractive correction, making the ether drift hundreds of kilometers per second, in agreement with Cosmic Microwave Background dipole observations and other modern versions of the Michelson-Morley experiment.

Analysis:

If the interferometer is at rest, or there is no relative motion of Earth through the ether, then the travel time t for both arms will be twice the distance L between mirrors divided by the speed of light c .

$$t = 2L/c$$

If there is a relative velocity v then the apparatus will move while the light is in transit between mirrors, as seen below. There will now be a difference between the time to cross the ether and the time to go back and forth along it. If the light is moving upstream in the ether, then it should take longer than to go the same distance downstream. For the path along the ether flow:

- with the ether: speed = $c + v$
- against the ether: speed = $c - v$
- time t' to return to the beam splitter

$$\begin{aligned} t' &= L/(c - v) + L/(c + v) = L [(c - v) + (c + v)]/(c^2 - v^2) \\ &= 2Lc/(c^2 - v^2) = (2L/c) / (1 - v^2/c^2) \sim (2L/c)(1 + v^2/c^2) \end{aligned}$$

For the path across the ether flow:

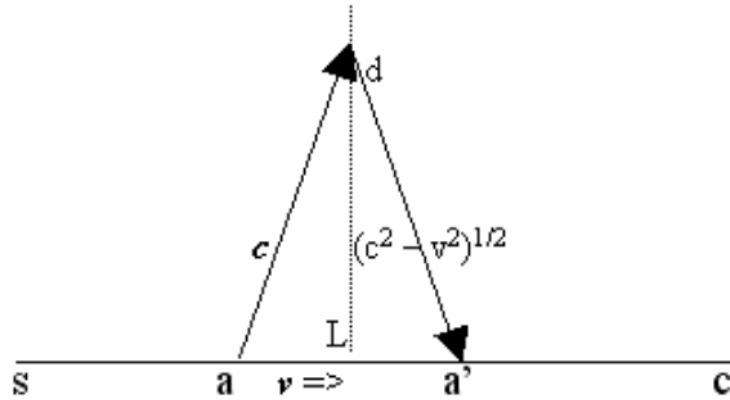

The beam path with an ether cross wind

The speed of the light beam along L is found from the Pythagorean theorem:

$$c'' = (c^2 - v^2)^{1/2} = c(1 - v^2/c^2)^{1/2}$$

The time to traverse ada' is:

$$t'' = 2L/v = (2L/c)(1 - v^2/c^2)^{1/2} \approx (2L/c) (1 + v^2/2c^2)$$

Then the travel time difference between the two paths seen at the interferometer is:

$$\Delta t = t' - t'' = (2L/c)(1 + v^2/c^2) - (2L/c) (1 + v^2/2c^2) = Lv^2/c^3$$

if

$$\Delta t = 0$$

constructive interference will form a bright spot. If

$$\Delta t = \lambda/2 = \text{half a wavelength}$$

A dark spot will form by destructive interference. In general the number of complete periods, N , by which the two waves interfere, is:

$$N = \Delta t/T = Lv^2/(Tc^3)$$

The period of the monochromatic light wave is the inverse of the frequency: $T = f^{-1}$. Michelson rotated the device 90° to interchange the path lengths and double the fringe shift for the total path difference between the two rotated perpendicular axes. This is the distance

difference traveled by light between the parallel and transverse ether direction for a 90° interferometer rotation:

$$\Delta N = 2Lv^2/(Tc^3)$$

Results:

Michelson-Morley expected to see a difference in the interference patterns for the two perpendicular orientations of the interferometer, showing that light traveled at different speeds in different directions. Assuming heliocentrism, and a rigid ether at rest, a shift of 0.4 fringe was expected for the Earth's orbital speed of 30 km/s = 1/10,000 of c . Fringe shifts should be observable if ΔN is around 0.01 – 0.02 fringe. They found that the fringe shift was much less than expected, < 0.01, but not quite null. Later experiments measured larger effects.

So no ether wind was detected (In the analogous model above: no water flow felt on the hand). Instead of discovering the properties of the ether, the Michelson-Morley experiment found one-fourtieth of the expected fringe effect and one-sixth of the expected velocity. With the exception of Dayton Miller, future Michelson-Morley type results returned what is considered a “null” result. Lorentz recognized that the Miller results, whatever their cause, did not quite tally with versions of Special Relativity. Einstein concluded that the results should be dismissed as experimental error. As interpreted since, the Michelson-Morley experiment is considered to be the first strong evidence against the theory of a luminiferous ether. This opened the door to the wild mathematical speculation divorced from experimental proof so rife in theoretical physics today.

Experimental Errors:

The Michelson-Morley type experiments that followed showed a small positive velocity, too small to show the presence of ether wind, sometimes within the error limits, sometimes not, but never exactly zero. The original Michelson-Morley experiment showed a small consistent ether wind – never exactly zero – but well within the devices' capability to detect. But then preconceptions twisted the reported results. Miller outlines how Michelson-Morley actually averaged the day and night readings in 1904 when the results were published! What happens when you average two sine waves that are perfectly out of step? Miller also argued that there was little possibility of detecting an ether wind since it was almost completely blocked out by the laboratory walls or by the apparatus itself. He realized that if matter, or a magnetic field, had any interaction with a fluid-like ether, there would be an entrainment effect, ruling out a basement lab site.

Many questions have been raised even to this day about the experimental protocol and what exactly Michelson-Morely were measuring. The results of many similar Michelson-Morely type experiments shows the measurements are never zero, but average about 3% of the expected values. The post Michelson-Morely experiments, especially the meticulous work of Dayton Miller, supported the geocentric origin of this small but persistent non-null result.

Theoretical Errors:

Michelson-Morley found a “null result,” a term much abused and misused. It doesn’t mean no motion was detected, but only that the measured result could not confirm the hypothesis of an ether, at the precision used in the experiment. In other words there was a lack of proof, not a disproof, of the existence of ether. The null result was unexpected, even though the effects were: (a) not measuring OWLS – one way light speed – but TWLS – two way light speed, as the difference between the two trips, and (b) the effect was of second order in v/c .

Michelson-Morley experiments have only been performed in terrestrial laboratories, where the gravitational field and the magnetosphere of the Earth and other ambient factors are always present. A repetition in space will remove these local features and allow a universal conclusion. This is also true of similar experiments dependent on ether motion or density. Many exotic experiments have been conducted in space, but those that might test Einstein’s postulates have never been done, yet. (NB: A positive result from the current test of General Relativity theory, called Gravity Probe B, will not only support frame dragging, but also many ether theories.)

Modern interpretation:

Science was at a crossroads. Either Geocentrism was to be accepted as true or a new anti-geocentric paradigm had to be introduced to replace Heliocentrism. The impasse was broken with Special Relativity theory, which opted for the following:

- c is constant
- no preferred reference systems, like Heliocentrism or Geocentrism.
- All motion is relative.
- no need for ether
- Lorentz contraction of lengths
- clocks run slow.

The development of Special Relativity derived the Fitzgerald-Lorentz contraction from the invariance postulate, and was also

consistent with the apparent null results of most experiments (although not with Miller's long-term seasonal effects). Today Relativity is generally considered the solution to the Michelson-Morley null result. Ritz's emitter or ballistic theory was also consistent with the results of the experiment, also not requiring ether, but it predicted wild gyrations of binary star light due to arrival time differences as they orbit each other. Interferometer observations of normal behavior seemed to rule out the ballistic theory, until it was rescued by the extinction model.

Four possible explanations were offered, three by Michelson, to explain the null Michelson-Morely outcome:

1. The Earth is fixed in the ether: Although obvious, Michelson still excluded this from his list of possible options! This is clear evidence of the anti-geocentric mindset of science at this time. Heliocentrism had been promoted as true since Galileo's time but still had not been logically proven. The evidence points to Geocentrism, but modern science denies it, and keeps denying it, no matter what the evidence placed before them.
2. There was no ether drag, as the ether was forced to move with the Earth.
 - a. There were at least two strong problems with this option: conflicts with other drag experiments.
 - b. A big problem: the Airy failure had been resolved with a dragging effect through the ether!
3. Light speed was constant with respect to the source
 - a. There were at least two strong problems with this option: conflicts with other experiments on the properties of light.
4. An *ad-hoc* offering: distances shrink (Lorentz contraction) along the motion's direction. This also presented problems:
 - a. There was no other independent evidence for this alleged contraction
 - b. It must be universal for all types of material, air, water, steel, etc.
 - c. No underlying mechanism to explain or implement it was proposed.
 - d. Contradicts the Sagnac effect, which shows no shrinkage of lengths.

Geocentrism's Response:

The anti-geocentrism posture was probably never more evident than in Michelson's strained effort to avoid concluding the Michelson-Morley experiment showed the Earth at rest, including a shrinking of size in the moving frame! But this was a conclusion that a child could have reached. The 'null' result left the heliocentric folks in a real bind.

- If there's no ether, then there's no Fresnel drag to explain away Airy's failure, and Geocentrism becomes the logical choice.
- If there is a fixed and absolute ether, the experiment should detect the relative motion of the Earth around the sun through it, but no proof of orbital motion was found!

The obvious conclusion was that no motion was detected because the Earth is fixed! Note that we cannot suppose in advance anything about the motion of the Earth. At Galileo's time, for example, experiments like Michelson-Morley's would prove that the Earth was stationary, since that was the dominant worldview. Today, Geocentrism is always the simple option overlooked.

Summary:

Some say the Michelson-Morley experiment is the keystone on which the second postulate of Special Relativity is based. This null result is the basis for justifying time dilation and the host of other paradoxical properties of relativity. Most say the result was within the error of the mechanism but this is not true in Dayton Miller's experiments or in the light of all the modern evidence since. The Miller and Michelson-Morley type experiments had very significant and reproducible non-null results.

One of the apocryphal aspects of the Michelson-Morley experiment is the fact that the readings plotted out to a sinusoidal wave with a single rotation periodic effect, exactly as expected of the ether wind. Moreover, the wave's phase was exactly opposite at night, as expected for a reading on the other side of the Earth.

Even with questionable construction, location and extremely low precision, there was definite proof of ether's existence all the way back in 1887, with only 6 hours of observations!

Conclusions:

Ruling out the existence of ether from either the Michelson-Morley or Miller experiments seems to be illogical in the extreme. Almost all other Michelson-Morley type experiments are performed in some sort of metal container in basements and other obstructive situations. Using the concept of entrainment totally invalidates all of their subsequent results.

The ether theory virtually died with the acceptance of Special Relativity. Einstein said that the Galilean transformation was only a low velocity approximation to the truth. By applying the Lorentz transformation to all inertial reference frames, he alleged that not only physics laws remained covariant but also c was invariant. The null results were now expected and the usefulness of the single universal

ether frame vanished. Now location in space or time was not absolute, but depended on the observer's location and speed.

As for the ether, having no proof of existence is not the same as a proof of non-existence. Of the many paradoxes of Relativity, one relates directly to the ether. Einstein simultaneously proposed that in Special Relativity there is no ether, yet in General Relativity space is curved yet empty! Although Special Relativity theory ignores ether, General Relativity theory does not, but uses "curvature of spacetime" as a euphemism for a space that affects matter. For example, look at one model of "spacetime" filled with a structure called the "spin foam." Similar to ether, the foam uses a privileged reference frame and thus is not Lorentz invariant, but which is a required symmetry of Special Relativity. It disagrees with the Michelson-Morley experiment. Yet this is a credible modern theory, having the blessing of General Relativity theory to forgive its clash with logical consistency.

Modernists claim that ether makes it much harder to remain consistent with all of the relevant modern experiments in physics. This premise hangs on rejecting an immobile Earth, a possible causative agent in ALL experiments investigated so far. Modern science dismisses many conflicts and inconsistencies with the mantra, "out of sight, out of mind." Contrary evidence to the relativity theory paradigm is treated not as a challenge, but with contempt. Scientific ignorance is bliss. Fortunately, some objective physicists are only now realizing, from other astronomical evidence, that a viable possibility to explain the Michelson-Morley experiment is that the Earth is stationary, the focus of the whole universe. Yes, the dreaded word - geocentrism.

Lodge 1892:*Aberration and ether drag:*

A uniform ether flow causes no aberration, which only depends on observer motion, according to Bradley. Ether drift has no effect on terrestrial surveying results. Although the ether drifts, it must be uniform everywhere, with no boundary between ether in two different states of motion. At such a boundary the light beam would change direction and appear to lag behind the true position, in proportion to the boundary-ether difference, as compared to a light beam not crossing the boundary. Such a negative aberration has not been seen.

If matter has no interaction at all with a frictionless inviscid ether (i.e., no ether drag), then aberration will not occur. The persistent motion of the Earth or planets over time through a viscous ether shows that any ethereal viscosity, if it exists, is beyond detection now. Energy lost to the ether would slow planetary motions down, is not observed.

Interference and refraction experiments were performed by Fizeau, Hoek, Jasmine, Mascart, Maxwell, Fresnel, Arago and Airy. None of the results implied an ether stream moving over the Earth's surface. The theory of astronomical aberration would be hopelessly complex if ether were dragged across the starlight before entering or inside the telescope.

Lodge's experiment:

If ether does not drag matter with it, is the reverse possible - that matter drags ether? Will a substantial mass disturb the ether? Lodge used large steel disks spaced apart and mounted on a rotating platform, with four mirrors positioned as in the Sagnac experiment to produce interference effects between counter-moving light beams. The difference was the large spinning frame that supported the mirrors. Lodge supposed the steel mass would drag the ether enough to be detectable. His first attempt showed a substantial fringe shift, thought to prove the existence of "matter drag" of the ether. But when the rotation sense was reversed, the fringes shifted in the original direction – the fringe shift was due to the change in air density and refractive index n due to the motion of the steel plates! Lodge also used charged plates to produce an electric field in the gap containing the light beam, and also iron magnets instead of steel. Still no fringes were noted when the spurious shift due to the change in refraction properties of air was eliminated (with much difficulty). The result was summarized as:

the velocity of light between two steel plates moving together in their own plane an inch apart is not increased or diminished by so much as 1/900 (0.0011) part of their velocity.

Result:

Oliver Lodge performed experiments on the propagation of light near rapidly moving steel disks to test Stokes hypothesis that moving matter drags the ether with it. No such effect is observed.

Trouton-Noble 1903:

The experiment was based on a suggestion by George FitzGerald that a charged parallel-plate capacitor moving through the ether should orient itself perpendicular to the motion, by experiencing an impulse when it is charged or discharged. Like the earlier Michelson-Morley experiment, Trouton and Noble obtained a null result: no motion relative to the ether could be detected. Trouton suggested that a turning force couple on a carefully insulated charged condenser moving through the ether might be detectable. This also produced a null result.

This null result was repeated in experiments by Chase in 1927 and Hayden in 1994. Such experimental results are now thought to be consistent with Special Relativity, to reflect the constancy of the speed of light and the absence of any absolute rest frame (or ether).

Experiment details:

In the experiment, a parallel-plate capacitor is charged and suspended by a fine torsion fiber. If the ether theory were correct, the change in Maxwell's equations due to the Earth's motion through the ether would lead to a torque causing the plates to align perpendicular to the motion. The electromagnetic energy of the condenser will have its lowest value if the plates are perpendicular to the direction of motion. Trouton concluded that the turning couple will try to put the plates at right angles with impetus from the velocity of the ether. The charged condenser moves through the ether with a velocity in the X-direction with its plates parallel to the direction of motion. If the plates are oppositely charged and edge effects are ignored, there will be a constant electromagnetic field between the condenser plates, and no field outside. When a condenser is at rest in the ether, there is only an electric field.

When moving through the ether, there will also be a magnetic field. The electric field \mathbf{E} points across the plates; the magnetic field \mathbf{B} caused by the charge motion is perpendicular to both \mathbf{E} and \mathbf{v} . There would be no \mathbf{B} -field if the condenser were moving with plates perpendicular to the velocity. The energy to create the magnetic field was thought to come from a decrease in the kinetic energy of the condenser, which would be detected as a decrease in speed.

Trouton tried to get the torsion balance to oscillate in its resonance frequency by charging and discharging the condensers at

intervals corresponding to the free period of swing of the apparatus. He did not find any effect. But Special Relativity says that Maxwell's equations are invariant for all frames of reference moving at constant velocities, so no torque is predicted (a null result). The experiment is very difficult to control – small effects due to external electric and magnetic fields make it difficult to separate a positive from a null result.

Geocentrism's Response: Only light and gases show ether effects; the experiment was incapable of achieving ether detection unless a charged gas is used between the plates.

Trouton-Rankine 1908:

Fitzgerald and Lorentz had independently proposed a contraction to explain the null result of the Michelson Morley experiment. Lorentz showed that this hypothesis, along with proper time, made Maxwell's equations and the Lorentz force law invariant in a moving frame, in agreement with Special Relativity.

In Special Relativity, the Lorentz-Fitzgerald contraction is not detectable in a co-moving frame. Trouton and Rankine saw that a contraction of the object in the moving frame should be measurable in the object's rest frame. To measure this effect was the experiment's purpose.

Because the Lorentz-Fitzgerald contraction is only in the direction of motion, from the point of view of the absolute ether frame the length of the resistance coils depended on their angle with respect to their ether velocity/drift. The resistance in the rest frame should change as the device was rotated. However careful measurements showed no change in resistance.

In 1908, Trouton and Rankine measured the change of resistance of a wire when oriented from parallel to transverse to the ether drift. They used a Wheatstone network for precise resistance determination. A Wheatstone bridge is a clever measuring setup used to measure an unknown resistance by balancing two legs of a network circuit. The bridge was balanced when the wire in two of the coils was at right angles to the ether drift and then the whole assembly was rotated through 90 degrees and the change of balance was tested. Every conceivable precaution was taken, but still there was only a negative result.

After rotating the bridge by 90° , Trouton and Rankine calculated the equivalent resistance by taking into consideration the Fitzgerald contraction. If the Fitzgerald contraction existed, since the resistance is directly proportional with the length, Trouton expected to see a change in resistance given by the derivation that follows.

Analysis:

The resistance of an elliptical wire of length l , resistivity ρ , area S and axes a , b is:

$$R = \rho l/S = \rho l/\pi ab$$

For motion along the wire axis the length l contracts according to Lorentz to become:

$$l' = l/\gamma \quad a' = a\gamma$$

so l contracts, a expands and b is unchanged, because it's perpendicular to the motion. The equilibrium resistance:

$$R' = \rho l'/\pi a'\gamma b = R/\gamma^2$$

For motion along the elliptical axis a :

$$l' = l\gamma \quad a' = a/\gamma$$

At 90 degrees the resistance is:

$$R'' = \rho l\gamma/\pi(a/\gamma)b = R\gamma^2$$

The change in resistance due to rotation in the ether wind causing Lorentz contraction is:

$$\begin{aligned} \Delta R &= R(\gamma^2 - 1/\gamma^2) \\ &= R[1/(1-v^2/c^2) - (1-v^2/c^2)] \sim R[1 + v^2/c^2 - (1 - v^2/c^2)] \\ \Delta R &\sim 2Rv^2/c^2 \end{aligned}$$

This resistance change can be precisely measured with the Wheatstone bridge setup. After rotating the balanced bridge by 90° , the bridge should become unbalanced by an amount ΔR . Trouton and Rankine observed a near-zero deflection, i.e. a deflection several orders of magnitude smaller than predicted by theory. This experiment marked the end of the Lorentz-Fitzgerald contraction theory. The experiment has been re-enacted several times with the same results and higher precision.

Conclusion:

This test showed that, if the Lorentz-Fitzgerald contraction existed, it was not measureable in the rest frame of the object. This

experiment has been re-enacted several times by Chase and Tomaschek at a higher precision with the same results.

Kennedy-Thorndike 1932:

Kennedy-Thorndike specifically tests whether c , the speed of light, depends on the velocity of the laboratory. Special Relativity states that the speed of light is the same no matter how fast an observer is traveling. The experiment monitors the oscillations of a light source as it accelerates and decelerates from the combined motions of rotation and orbital revolution. By making one arm of the experiment much shorter than the other, a change in speed of the Earth would cause changes in the travel times of the light rays, from which a fringe shift would result unless the frequency changed by the same amount. One arm was very long and placed north-south. Opposite ends of the experiment were thus at different rotation velocities due to their slightly different latitudes, so the length contraction would not cancel out for east-west motion. As no significant fringe shift was found, the experimenters concluded that time dilation occurs as predicted by Special relativity: “the conclusion to be drawn is that the frequency of a spectral line varies in the way required by relativity.” Without the time dilation, the Lorentz contraction hypothesis is unable to explain the null result from this experiment.

Special techniques:

Several unique protocols were used in this experiment:

- The apparatus was kept at temperature constant to 0.001°C over several seasons.
- Fringes were photographed.
- It used a fixed laboratory to look for diurnal and seasonal variations as it moves along with the Earth’s spin and orbital motion.
- Its mirrors were modified to include a half-wave “step,” eliminating the possibility of a standing wave pattern within the apparatus.
- It had precision of $1/1500$ fringe or $1/4$ degree in phase angle
- It employed the first actual vacuum interferometer
- a null result implies the estimated ether drift was $v < 24 \text{ km/sec}$.

An entrained ether was discounted by the experimenters; in their own words:

In view of relative velocities amounting to thousands of kilometers per second known to exist among the nebulae,

this can scarcely be regarded as other than a clear null result.

This statement serves to illustrate how deeply ingrained were both the Big Bang model and the concept of a static ether.

Hamar 1935:

Instead of passing through a static and unmoving ether, massive objects at the Earth's surface may drag some of the ether along with them, making it impossible to detect an ether wind. Hamar intended to cause an asymmetry in any proposed ether wind. If there was any ether wind at all to be detected, the leg of the interferometer with containing lead should have experienced less ether wind than the other leg. Hamar's expectation of the results was that:

- a) In an experiment without lead blocks, both arms would be equally affected by ether entrainment.
- b) In an experiment with lead blocks in place on one arm, only one arm would be affected by ether entrainment.

The reported result concluded, even with the lead blocks in place, the fringe displacements were equal to the ones without any lead blocks. This was presented as proof against the ether-drag hypothesis.

Interpretation:

Because differing ideas of "ether drag" existed, the meaning of the experiment depends on each version of the hypothesis. There are two main levels of drag that have been proposed:

- (a) Partial entrainment by any object with mass, as taught by Fresnel and Arago.
- (b) Partial entrainment at larger, perhaps even global magnetic field level, as believed by Michelson and Miller.

Frisch-Smith 1962:

This was a demonstration of time dilation carried out by Frisch and Smith in 1962. Because a mechanical clock could not be accelerated to a speed close to the speed of light, they chose to observe the decay rates of *mu* mesons (muons), i.e., cosmic-ray fragments.

Cosmic rays carry extremely high energies into Earth's atmosphere from beyond the solar system. When a ray strikes an atom in the atmosphere, it creates a cascade/shower of high-speed particles, including muons. Once a muon is created, its lifetime is a statistical

variant, depending on its probability of decay, expressed as a half-life. Muons have a half-life of 1.523 millionths of a second. In each half-life, half of the remaining muons decay to other particles. Reasoning in reverse, if the number of muons created is known, and then the number at some later instant is counted, then elapsed time in the muons' inertial frame can be computed.

Frisch and Smith set up their apparatus on Mount Washington in New Hampshire at 6265 feet above sea level, where they detected an average of 563 muon decays per hour. The flight to sea level takes 6.3918 microseconds, which spans 4.197 consecutive muon half-lives. If time in the muons' frame were not dilated relative to the lab frame, then that flux of muons would drop from 563 per hour on Mount Washington to about 31 per hour at sea level. If the muons' time is dilated, then the Lorentz factor for a relative speed of 99.52% of light speed equals 10.22, which expands the muon half-life to 15.565 microseconds. The muon flow would shrink at sea level to 423 per hour. Data was then collected at 10 feet above sea level. At this location muons were measured at an average rate of 408 per hour vs. the theoretical rate of 423/hr.

Conclusion: Since the muons are travelling nearly the speed of light, their internal clock is slowed by the amount accounted for by Einstein's special relativity so that more reach sea level than otherwise expected. Muons generated in cosmic-ray showers decay in dilated time.

Geocentrism Analysis:

- In all inductive (empirical) proofs, the understanding is that positive examples only support a theory. Only a deductive proof from an outside body of knowledge – like theology – can assert the truth. Time dilation supports but does not prove Special Relativity.
- Special Relativity is not applied correctly in the standard analysis above. The focus is on time dilation, but Lorentz transformation symmetry requires a corresponding length contraction in the other frame, and Lorentz contraction is simply ignored. The two known values are in different reference frames: the half-life is known in the meson rest frame; the altitude at which decay occurs is known in the ground rest frame. For the speed of mesons the gamma factor is 10.22, so the contracted altitude is 613 ft in the meson's frame – see table below.

Frame	Half life	Average range
Meson	1.523 usec	613 ft
	↓	↑
Ground	15.565 usec	6265 ft

The claim that the meson will not reach the ground is empty, if the Lorentz contraction of altitude is considered. The ground is only 613 ft away! So the mesons will reach the ground at the rate observed, whether seen from the meson view or from the ground. There is no paradox. But it is expedient to ignore this, in order to focus on the time dilation alone.

- Other experiments show Lorentz contraction doesn't exist. The argument above is thus moot, but important in deconstructing the Special Relativity argument favoring time dilation.

DePalma spinning ball drop:

A ball spinning at 27,000 RPM and a non-spinning ball were catapulted side-by-side with equal momentum and projection angle. In defiance of all who reject the ether as realistic, the spinning ball actually weighed less, and traveled higher than its non-spinning counterpart. Those who attribute this to an aerodynamic or atmospheric effect, please note that it works just as well in a vacuum. Also note, this effect has since been verified by other [enlightened] researchers.

The decrease in weight of the spinning ball – anti-gravity – can explain why the spinning object goes higher and falls faster than the identical non-rotating control. Current thinking is that there is no special interaction between rotation and gravity. The behavior of rotating objects is simply the addition of ether energy to whatever motion the rotating object is making.

Is this a harnessing of torsional ether waves by rotation? Both balls draw energy into themselves from an unseen source, but the rotating ball absorbs more of this ethereal energy than its counterpart – energy that would be manifest as gravity, moving down into the Earth. With a decrease in torsional ether above the ball, there is a slight decrease in gravity, the ball gets slightly lighter. Needless to say, this effect defies standard theories.

Gyro Drop: A fully enclosed, electrically driven gyroscope is released to fall freely under the influence of gravity. The elapsed time taken to fall a measured distance was photo-timed, with the rotor stopped and then spinning. The gyroscope fell along its axis. Power leads for the rotor were disconnected just prior to release.

	Static	Rotating
Acceleration (ft/sec ²)	32.1549	32.2619
Delta acceleration	.1070	
Equivalent force difference	.38oz / 7.23lbs = 0.33% weight loss	

With 97% statistical confidence, the difference in the fall rate for the spinning and static balls is not due to chance.

Quantum red shifts, Tift 1984:

William Tift noticed a curious relationship between a galaxy's shape (Hubble type), brightness, and red shift. Coma Cluster galaxies configured themselves along sloping bands in a red shift vs. brightness diagram. Several well-studied galaxies, including M51 and NGC 2903, exhibited velocity breaks, or discontinuities, or jumps – like steps on a stairway – at their nuclei which tended to be around 72 kilometers per second, independent of galaxy selected. Later on, smaller velocity jumps inferred from the red shift breaks were found: 1/2, 1/3, or 1/6 of the original 72 km/s value. The formal confidence levels associated with these quantum results are extremely high.

Tift's initial suggestion was that galaxy red shifts take on preferred or "quantized" values. Were red shifts analogous to atomic energy levels, a repetition in the macro world of features in the micro world? Why wasn't this obvious pattern noted before? Two reasons: (a) Precision was insufficient, (b) If the pattern was not expected, there's no reason to test for it.

Further evidence was needed. Binary galaxies physically correlated with one another can test for red shift quantization. The red shifts from their mutual orbital motion should be a smooth curve; there should be no jumps. But disparate analyses find the red shift differences between galaxy pairs are quantized rather than a continuum, discrete rather than analog. They cluster near multiples and factors of 72 km/s. Visible-light spectra was used first, but was not sufficiently precise for confidence. A 1980 radio survey of binary galaxies made in the 21-cm emission of neutral hydrogen provided the assurance of precision. Red shift quanta were grouped around 72, 144 and 216 km per second, a very unlikely coincidence. It now seemed that wherever the effect was sought, it was found. Statistical experiments over the entire sky, rather than galaxy pairs, were needed, but are much more difficult to carry out.

Dwarf irregular galaxies spread across the sky were next selected for surveying and statistical analysis. The dwarfs displayed an extraordinary clumping of red shifts into discrete bins of 24 km/s, 1/3 of the original 72 km/s interval. The likelihood that such clumping would randomly occur is just a few parts in 100,000, $< 10^{-4}$.

Next, galaxies in the Fisher-Tully catalogue that showed large amounts of rotation and interval motion (the opposite extreme from the dwarf irregulars) were studied. The galaxies' red shifts again were discrete, but this time hovered around 36 km/s, 1/2 of the basic 72 km/s spacing. The inescapable conclusion was that at least some galaxy types all over the sky have quantized red shifts that are simple fractions of 72 km/s.

Astronomers have now confirmed that numerical values of galaxy red shifts are ‘quantized’ into distinct levels. Hubble’s law treats red shifts as proportional to the galaxy distances, so the distances also fall into groups of concentric spherical shells around us. Since the shells are about a million light years apart, our distance from the center must be much less than that, to avoid visual mixing. The probability of this occurring by chance is incalculable.

$$\Delta\lambda/\lambda = Hr/c$$

H is the Hubble constant, empirically derived, with wide interpretative range. Its current value is 75 km/s per Mpc (Megaparsec). This is the famous Hubble law, which says that red shifts tend to increase in proportion to distance. Hubble and Slipher said the wavelength shifts were Doppler shifts, produced entirely by the relative velocity v of the source and Earth. For non-relativistic speeds, the wavelength shift given by the Doppler formula is:

$$\Delta\lambda/\lambda \sim v/c$$

which implies that

$$v \sim Hr$$

In models of Einstein’s theory of General Relativity that include an expanding space, such as the Big Bang, light from distant stars would stretch more than from nearby objects, so Big Bang red shifts would increase with distance. Theoretical physicists (cosmologists) hold that the Hubble relation represents a Big Bang expansion red shift of all space, not a Doppler shift. The additional proper motion of the star is a Doppler shift. But experimental physicists (astronomers) choose to describe red shifts with velocities equivalent to a Doppler shift, with a single value, not two. This practice has long confused the public, the media, and even the astronomical community into thinking of the red shifts as being caused only by velocities of the objects. The persistence and prevalence of this confusion is hard to fathom, since it can be reinforced by emphasis in standard textbooks and press releases. The distinction is rarely made. It does benefit, however, those who need flexible interpretation of red shift data to prove or disprove a specific issue. Perhaps Relativity theory refers to the relativity of interpretation.

In summary, then, galaxy red shifts are approximately proportional to velocity and distance as expressed quantitatively in the Hubble law. Ground telescopes show quantization at least out to medium distances, of the order of 100 million light years. The Hubble Space Telescope shows similar clustering of red shifts out to distances of billions of light years. In 1996, Tifft showed that Milky Way motion in

the cosmic microwave background (CMB) frame must be compensated for: 560 km/s in a direction south of the constellation Hydra. In this Cosmic Microwave Background rest frame, red shift groups have much greater definition. Smaller levels like 2.6, 9.15, and 18.3 km/s become evident. Validity of the data is no longer questioned, but an explanatory theory has not been found – in modernist physics, that is.

Why do the red shifts of particular types of astronomical objects only take on certain values, suggesting that the objects are on shells concentric around the Earth, implying the location of the Earth is special? No modern cosmology models explains this periodic grouping of galaxy red shifts around discrete values across the span of the universe. This is no minor anomaly.

Claims and Responses:

Claim #1: The universe is a huge spherical resonant cavity, tuned to the Cosmic Microwave Background wavelength, with nodes in between galaxies, which are the maxima of the Cosmic Microwave Background standing waves.

Response: Then why are there not resonances in the ether flow?

Claim #2: If the Doppler shift is rejected, the accepted interpretation of the red shift, then the distance to galaxies is unknown, because the Hubble Law is invalid. If the red shift is entirely or partially non-Doppler and not due to cosmic expansion, then it could be an intrinsic galactic property, such as mass or luminosity. Each galaxy may have a state specific to itself, like the characteristics of individual humans. Relatively little blurring in the quantization means any real motions must be small compared to the internal state. Galaxies would have little relative motion, sitting static in the universe instead of expanding.

Response: It is rejected because the main pillar of the Big Bang is the Hubble red shift, proportioned to distance and recessional velocity. This crisis cannot be permitted.

Claim #3: Gravitation creates clusters of galaxies with similar red shifts.

Response: But then the clusters should be independent, not coordinated across the visible universe.

Claim #4: A quantum red shift operator theoretically will create discrete eigenvalues of a wave equation.

Response: But if it is a wave equation, what is waving? If a quantum operator, why a cosmic scale, when quantum mechanics has always

applied to the microworld. And what is the physical mechanism behind the mathematics?

Claim #5: Those scientists who believe in quantized red shifts represent a very small minority.

Response: How many are aware of the effect, and have researched its claims and implications? Hardly any.

Claim #6: Some scientists hold that causes of uneven patches of matter are due to a fluctuation of the Big Bang spatial explosion, large-scale structures and local clustering can mimic the appearance of red shift quantization.

Response: But this is nothing but grasping at the wind, as we have seen with inflation, dark matter, dark energy, multiple universes, etc.

The Geocentric view:

Contemporary science contends galaxy red shifts are seen from a moving platform, the Earth. Local Doppler red shifts would be imposed on the red shift readings taken directly from the telescope. There is the orbital motion of the planet, the motion of the solar system (the sun), the Milky Way, and the Local Group – all with separate speeds and directions through space. This set of motions, incompletely known, would have to be subtracted from each red shift motion to eliminate the grand procession of the Earth and the groups to which it belongs. But subtraction or correction is only done for the first two motions – the orbit around the sun and the solar motion around the galaxy center, the galactocentric frame of reference! The Milky Way motion and the motion towards Leo were unknown at the time and were not taken into account, yet they represent the largest component of the Earth's motion – about 600 km/s! This is huge compared to the levels observed – as low as 12 km/s. Are we to believe that from all other locations in the universe we will observe this same quantum red shift by embracing the rule of uniformity – the cosmological principle? How can the red shifts exhibit the quantum breaks without any further data massaging for the largest motions? Unless, of course, the motions of the Earth are fictitious!

If Earth were not central, arcs of each shell would be seen with varying red shifts. In geometry, concentric circles can have but one center. All quantum red shifts indicate that the Earth is the center of this incredible phenomenon. Any other location would break the quantum levels, smearing them out, as was expected prior to the discovery by Tiff.

Geocentric theory summary:

The basic premises are:

1. Red shift spacings correspond to groupings of distances
2. Galaxies are located in concentric shells around us
3. This effect could not be accidental.
4. Red shift jumps strongly support the view that we are the physical focus of the universe.

The Red Shift anomaly (1990):

Claim: Red shift data interpreted according to the Big Bang standard model asserts that most star systems are radially receding from Earth; some in deep space are doing so at speeds close to (more than half) the speed of light. Over a six-month interval, stars on the ecliptic will show a radial velocity variation of about 60 km/s, which is due to the Earth's 30 km/s orbital speed. The Earth's rotation and revolution are removed from the computation and the observed radial velocity is specified relative to the sun, the heliocentric radial velocity. The radial velocity is easy to obtain from a spectrograph and the precision is independent of distance, unlike proper motion and parallax.

Response: All physics discussions base the redshift anomaly on the premise that the Earth is moving around the sun. As described above, computations are transformed to the heliocentric system, with the intent of eliminating the Earth's motion from the data. This only serves a counter purpose if the Earth is stationary in space. The heliocentric corrections give motion to the Earth it doesn't really possess, and from those erroneous "corrections," which are based on a false premise (i.e., the Earth is moving), is generated a false conclusion.

If the heliocentric correction were applied, the only way the annual red shift variation could be tested (NB: tested, not speculated) would be to put a measuring device at the sun's location and record the Doppler shift from any given star. That this is a practical impossibility is no problem for the modern physicist, since empirical tests are replaced by pure thought – gedanken experiments. The proof is unfalsifiable.

Finally, even if the redshift could be measured from the sun's location, all that would tell us is the relative motion between the sun and the star. The shift would be exactly the same, regardless of whether it is the sun or the other star that is stationary, or even if both are in motion.

Cosmic Megawalls (1990):

Observations are made of galaxy redshifts within a cone of observation 7 billion light years long and centered on the Earth. The analysis relies on the modernist Hubble law – that red shifts are truly indicative of distance.

Mirabel and Rodriguez Superluminal Galactic Source 1994:

Apparent velocities greater than c (superluminal) have been inferred for radio-emitting components in a number of distant quasars and active galactic nuclei. The central object emits jets of subatomic particles from its poles; in these jets the rapidly moving material was tracked. The components were moving from the center at rates greater than c . The accepted explanation: plasma clouds were ejected in opposite directions from the core at speeds close to c ; relativistic effects led to the apparent superluminal motion. But analysis of deep space objects introduces many potential errors of assumption.

Mirabel and Rodriguez saw the first superluminal motion ever detected in an intragalactic source. The source is ejecting matter in a similar process but on a smaller scale than that seen in quasars. Using Very Large Array (VLA) technology, they discovered that a small, powerful object in our own cosmic neighborhood is shooting out material at nearly the speed of light. After accounting for direction, the material appears to be traveling faster than c , superluminal motion, prohibited by Einstein's second Special Relativity theory postulate.

Relativity view:

Seeing a visibly-superluminal expansion or motion of a distant object does not necessarily imply that anything actually exceeds c locally. If a subluminal object is moving at a small angle along the line-of-sight it can appear to be going faster than light, but is not. This is different from any uncertainties in distance scales.

A remarkable ejection event was seen where the object shot out material in opposite directions. The core remained stationary, while the approaching bolide was apparently moving at 125 percent of the speed of light. After correcting for relativistic effects, they conclude that the ejected material actually is moving at 92 percent of light speed, more than 171,000 miles/second. This event ejected a mass equal to one-third that of the Moon with the power of 100 million suns.

Claims and Responses:

Claim #1: Thirty years ago superluminal motion was used as evidence against quasars having deep space distances. Today most physicists

believe that velocities greater than c are optical illusions and involve no physics which contradicts the theory of Special Relativity.

Response: Exactly what is acceptable evidence of speeds greater than light speed, if all visual proof is dismissed as illusions – ESP?

Claim #2: The superluminal explanation is a light travel time effect. Any light from glowing matter moving close to head-on towards Earth at nearly c will take a shorter time to travel as it nears Earth. If you don't correct for this decreased time the light speed will be overestimated. In other words, if you calculate how fast that blob is moving, assuming that it is moving perpendicular to the line between you and the galaxy, and you underestimate the time interval by ignoring the fact that it is also moving towards you, then you will get a speed which can be many times the speed of light.

Response:

1. Whether the source is moving toward, away from, or tangent to our sight line, Special Relativity theory says the observer will always measure c as constant. So it makes no difference.
2. This is a good example of how Relativity theory turns reason upside down. If an object approaches Earth at a small angle, it will appear to be moving much slower than it actually is, because only sideways/transverse motion is visible. The logic above argues that the object is moving much slower than it seems!
3. If time is shortened, so are the distances, by Lorentz contraction and the foreshortening by perspective in # 2

Binary Star Precession (1995):

Six analyses of the orbital precessions of the planet Mercury, the moon, the major satellites of Jupiter, Saturn, Uranus, and four binary stars have been done to examine whether classical Newtonian tidal effects may completely account for excess precession, eliminating a key proof for General Relativity.

Analysis of binary star precession:

- 1) For two binary stars, DI Herculis and AS Camelopardalis, General Relativity predicts double the measured orbital precessions.
- 2) The orbital period decay of binary pulsar PSR1913+16 has been attributed to energy lost via gravitational wave radiation, a General Relativity effect never detected in other experiments. This decay could also be a classical propagation speed of gravity several million times the speed of light, as Van Flandern has convincingly argued,

using the lack of gravitational aberration in astronomy. Such a speed would vitiate Special Relativity and General Relativity theory.

- 3) Classical tidal effects with a speed of gravity several million times the speed of light in a Euclidean 3D space and time reasonably explains the empirical orbit precessions and decays.

Orbital precession comparison

Binary Stars	GRT	Actual
DI Herculis	2.35 deg	1.05 deg
AS Camelo	26.8 deg	15.00 deg

Propagation speed of gravity:

For a speed of gravity equal to the speed of light in classical physics, the radial distance can change significantly. Applying equal speeds and Newton's law to the Earth-sun eccentric orbit yields a decay of 15 seconds per year, and a decrease in major axis of 30 miles per year. Neither of these orbital changes are measured. If gravity's speed is three million times the speed of light, the axis would only shrink about 0.6 inches per year.

Aspden Effect (1995):

An Adams motor with a magnetized rotor and no electrical power input is started on no load by a drive motor and brought up to operating speed of 3250 rpm, then runs steadily at that speed for two minutes. With a machine rotor of 800 gms, its kinetic energy and that of the drive motor is less than 15 joules, contrasting with the 300 joules needed to spin up from rest.

After five minutes or more, the machine is stopped, but can be restarted up to speed in the same or opposite direction with only 30 joules, only 10% of the original effort, provided that the machine is not stopped more than about a minute. This totally violates all known laws of physics. It is ten times easier to spin the magnet once it has already been spinning. (The term for this is *hysteresis*, a memory of prior physical states).

Energy within the magnet seems to continue "spinning" inside even when the magnet is not moving (similar to stirring up a glass of water and then removing the stirring rod, while the glass itself remains still). It will take less energy to stir up the water in the glass again if you wait less than a minute before trying. So it certainly appears that this

energy in a magnet is in a form of fluid motion, possibly spiraling in a vortex, like the water example.

The experimental evidence is that there is something that is:

- spinning,
- invisible,
- having energy of motion,
- occupying the space within the machine rotor.

This “something” has an effective mass density 20 times that of the rotor, but spins independently and takes several minutes to decay/wind down, while the motor itself comes to rest in a few seconds. Various machine configurations tested indicated two dependencies:

- time of day
- compass orientation of the spin axis.

One machine with weak magnets showed evidence of gaining magnetic strength with each test, as if permanently absorbing the ether energy.

Another separate experiment consisted of a reversible D.C. motor running in a clockwise sense for two or three minutes, drawing from the power supply, but then spontaneously slowing down, stopping, and then reversing rotation and rapidly gaining speed, as if counter-clockwise was the preferred sense of rotation. It was running well clockwise, with no external influence given to change direction.

The basic motor used by Aspden consists of a central rotor either all north out, or all south out, and high resistance coils.

The Basic CD Motor Configuration

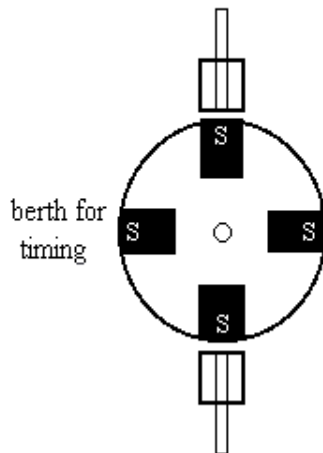

- Grade 8 ceramic / ferrite magnets are fine
- Rotor magnet faces should be 3/4" diameter
- Magnets spaced for 20% pulse duty cycle
- Individual stators should be 6 - 9 ohms
- 24 - 26 awg wire is suggested
- 12v input basic, then 18, 27, 36...
- Diode based path for back-emf to supply

Aspden rotor motor¹³⁵³

Aspden ether principles:

- 1) Extraction of energy from the ether does not violate the first law of thermodynamics, conservation of energy, if energy flows from ether to matter. If the ether delivers energy to run the motor, eventually that borrowed energy is returned to the ether by generating heat and radiation.
- 2) Existence of the ether was not disproved by Einstein. Special Relativity only says it is not necessary; General Relativity theory disguises it as “space-time curvature,” while moderns call it “the vacuum.”
- 3) Ether has been measured in laboratories. The ether was probably first detected by Sagnac in 1908, the experimental source of the modern ring laser gyro. How can the speed of a laser beam traveling a circuit inside an optical instrument detect rotation of that instrument, unless the beam is keeping a fixed speed relative to something inside that instrument that does not share its rotation? That something is the ether!
- 4) Its existence was not disproved by the Michelson-Morley experiment. Michelson was trying to sense the Earth’s motion through the ether, but violated the Miller condition for minimal ether shielding.
- 5) The ether reveals its existence when we have rotation, as in the Adams motor.

Marinov: The Self Accelerating Plasma Tube (1996):

Motor operation:

A cylindrical magnet is cut along one of its axial planes and the one half is turned up-down (the magnetic forces themselves do the rotation). Around this magnet there is a channel filled with mercury in which the copper ring floats. After sending a large current from the battery, the ring begins to rotate without any external mechanical stimulation.

Generator operation:

Mechanically rotate the copper ring clockwise and it will generate power in the same direction of current flow. Marinov has demonstrated and proved this in his tests. There is no opposing torque to the direction of rotation and the device is said to be self-accelerating. As

¹³⁵³ <http://upload.wikimedia.org/wikipedia/en/e/e8/Cdmotor2.gif>

long as power is drawn from it, it will power itself. Friction will easily stop the self-accelerating process, due to the low torques generated.

Atmospheric rotation:

The Earth's magnetic field has the same shape and properties as Marinov's cylinder magnet. The sun constantly supplies a current of charge via the solar wind, the same as Marinov's battery. By analogy the Earth's ionosphere will act like the copper ring and rotate as long as the electron flow is present – that is, constantly. The ionspheric motion, in turn, will drive the lower stratosphere and troposphere to produce their observed circulation patterns. An event supporting this idea was the unexpected vaporization of the tether used to connect two artificial satellites, an indication of a large current flow. Was it tapping into a huge energy reservoir that drives the global air circulation? The plasma tube has no mechanical parts; if friction can be reduced sufficiently, even the smallest amount of torque on the gas plasma will accelerate it.

Casimir Force (1997):

The Casimir force is counter-intuitive but well understood. In quantum mechanics, all fields, in particular electromagnetic fields, have fluctuations. At any given moment their actual value varies around a constant, mean value. Consider the gap between two plane mirrors as a cavity. Casimir realized that when two mirrors face each other in a vacuum, vacuum fluctuations exert radiation pressure on them. On average the external pressure is greater than the internal pressure, causing mutual attraction by the Casimir force.

All electromagnetic fields have a characteristic spectrum containing many different component frequencies. Inside a cavity, where the field is reflected off the walls of the container, the field is amplified if integer multiples of half a wavelength can fit exactly inside the cavity. This wavelength corresponds to standing waves or a "cavity resonance." Any other wavelengths suppress the total field. Vacuum fluctuations are suppressed or supported depending on whether their wavelengths correspond to a cavity resonance or not.

Radiation pressure of the electro-magnetic field increases with energy and frequency. At a favorable frequency radiation, pressure inside the cavity is greater than outside and the mirrors are repelled. At an unfavorable frequency, the inside radiation pressure is less than outside and the mirrors attract. Large wavelengths cannot fit between mirrors only microns apart, so the large wavelengths are suppressed, and also the inside radiation pressure compared to the outside pressure.

The force, F , is proportional to the cross-sectional area, A , of the mirrors and increases 16-fold every time the distance, d , between the mirrors is halved:

$$F \sim A/d^4$$

Two mirrors with an area of 1 cm^2 separated by a distance of $1 \text{ }\mu\text{m}$ have an attractive Casimir force of about 10^{-7} N – about the weight of a water drop. At separations one hundred times smaller and about a hundred times atomic size the Casimir effect produces 1 atmosphere of pressure.

Summary:

Two metal plates isolated in a vacuum are pushed together because the zero-point vacuum field pressing against the outside of the plates is a little stronger than that against the inside. The existence and intensity of the Casimir force have been experimentally verified many times in the 50 years since Casimir's revelation.

Claim: The presence of conducting metals and dielectrics alter the energy of the electromagnetic field in the Casimir effect.

Response: Since the energy depends on the shapes and positions of the conductors and dielectrics, the Casimir effect matches the characteristics of the ether, which is affected by the type, size and location of ambient objects, as Miller and others have shown. Is the modern quantum vacuum-field nothing more than the ancient ether?

Magnetic Memory, Roth (1997):

A magnetic torsion beam was suspended and balanced at its center. A strong magnet is then placed on a table with one pole facing the suspended torsion beam to attract it. After five days the magnet can be moved a considerable distance from the balanced torsion beam but the beam will still be attracted as though the magnet was still there. Note: The magnetic torsion beam is simply a bar magnet hanging on a string.

Interpretation:

If a magnet stays in one place long enough, it can cause the ether flowing through nearby objects to move in a certain preferred direction instead of in any random direction. Just the presence of the magnet close by provides the extra energy to keep the ether flowing.

With respect to this property of the ether, it acts like a siphon. Once the water flow is started in a siphon, atmospheric pressure will keep the flow going until the container at higher level is emptied into a lower level container. There is greater atmospheric pressure on the surface of the water compared to the smaller pressure at the hose end.

By analogy, if magnetism is an ether flow, once started through a local area of space, it can continue with the same force even with the starting magnet farther away. It is as if a temporary ether current is created in the fabric of space – certainly an atypical property of magnetism.

Wang Super-luminality (2000):

In Wang's experiment, a pulse of light passed through a small cell filled with specially treated cesium gas. A light beam traveling through the cell has two different velocities, a velocity for the individual light waves in the beam and a group velocity for the entire beam. Some light waves in the beam can actually travel backward, reversing the front and back edges momentarily. Different parts of the beam can leave the gas cell at different times, creating the effect that parts of the light beam have left the cell before other parts even entered.

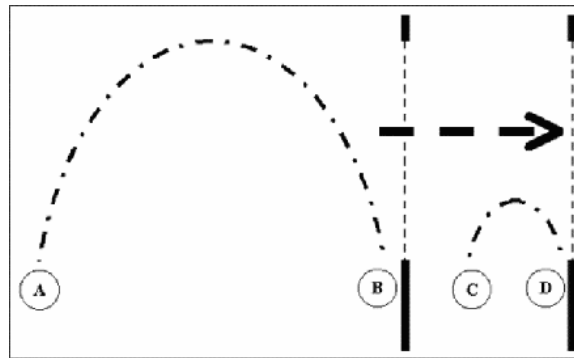

Wang experiment¹³⁵⁴

B-A are front and back edges of initial pulse
 D-C are front and back edges of transmitted pulse
 Height is light intensity, vertical dashed lines outline the Ce cell

- B and A are timed when entering the center slit in figure above, moving to the right
- D and C are timed when entering the right exit slit.
- The front edge B-D moves at c .
- The back edge A-C is timed moving faster than c .
- C actually exits the cesium cell before A enters it!

Before the trailing edge of the pulse had fully entered the cell it was detected 60 ft beyond the cell. This is bi-location, existence in two

¹³⁵⁴

<http://www.metaresearch.org/home/Viewpoint/archive/010824FTL/FTL%20Light%20Pulse.gif>

separate places at once, equivalent to traveling 300 times faster than light, according to Wang.

Problems:

- Light jumping forward in time implies an effect before its cause – a philosophical violation of causality.
- The clash with Einstein’s theory of Relativity which asserts c is isotropic and no object or information can travel faster than c .
- Italian physicists have also succeeded in breaking the light speed barrier, propagating microwaves at 25% above normal light speed c , supporting superluminality. Possibly the most important evidence that the physical world may not operate according to many of the accepted beliefs of Relativity.
- Aroused fierce debate over its meaning, interpretation and consequence for current beliefs.

Alternate explanations:

- pulses get distorted when passed through any media other than a vacuum
- Wang’s interpretation doesn’t tell the whole story; it can be interpreted incorrectly.
- even if such a beam can be proved faster than c , it would not be able to carry any information.

Holger Müller (2002):

Müller made use of two devices known as “optical cavities,” two mirrors held at a constant distance, pointing in different directions. A set of standing light waves in a chilled cavity was monitored over a 190 day period, more than 1/2 of the Earth’s orbit, altering the velocity of the equipment by a net change of 60 km/sec.

The round-trip time of a light beam between the mirrors is a direct measure of the speed of light perpendicular to the mirror surfaces. If c were to vary with lab speed, then the constant comparison of the standing waves to a highly stable atomic clock would fall out of resonance with the cavity. Any dependence of this speed on direction would be evident when the cavity is rotated.

To avoid errors caused by temperature effects and material aging processes, cavities were made from a pure sapphire crystal, virtually immune from aging, and operated at the temperature of liquid helium, near absolute zero. Being made of sapphire, the cavity has very little thermal expansion at a temperature of 4° K.

Using advanced laser techniques for reading the cavity round-trip time, a new limit on possible violations of light propagation isotropy was

established. The latest experiment is part of a whole new generation of Relativity tests. The stability of the resonance frequency produced a three-fold improvement in precision over past experiments. A 100-fold improvement in the near future is anticipated.

Protocol Precautions:

- relies solely on Earth's rotation – no turntable vibration.
- avoids the systematic effects associated with active rotation
- overcomes the creep of room temperature resonators made from glass ceramics, e.g., ULE (UltraLow Expansion)

Comments:

The experimental care taken in this experiment is impressive, but futile, if intended to detect the influence of the ether on c . Lessons learned long before have been forgotten. The experimenter's text below indicates the missteps taken: solid silica and sapphire crystal; and vacuum-sealed, instead of a gaseous medium.

At the core of the experimental setup is an optical cavity fabricated from fused silica ($L = 3$ cm, 20 kHz line width) which is continuously rotated on a precision air bearing turntable. Its frequency is compared to that of a stationary cavity oriented north-south ($L = 10$ cm, 10 kHz line width). Each cavity is mounted inside a thermally shielded vacuum chamber.

The apparatus diagram, although only a schematic, indicates the clutter of support and ancillary structures used in a vain attempt at accuracy. It is also a safe assumption the experiment was performed in a laboratory, buried in the bowels of a building. Can sunlight be detected in a windowless cellar? What value would be placed on a null result of $< 10^{-15}$ for sunlight detection, if the cellar shielded the detector from the sun? Would we say there is no sunlight, because the experiment was done in darkness? Modernists should review the Miller experiment of 80 years ago.

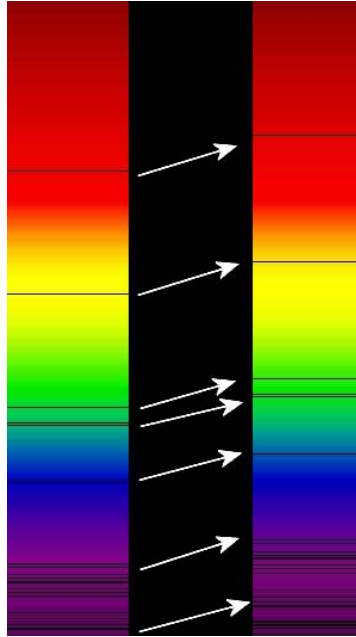
Quasars in galaxies (2004):

**Redshift of optical spectrum in a distant supercluster(right),
as compared to the Sun (left).¹³⁵⁵**

NGC 7319 is a Seyfert 2 galaxy with a small red shift of 0.0225, shrouded with heavy dust clouds that obscure the bright, active nucleus. Big Bang theory understands red shift as proportional to distance – the larger the red shift, the farther the object must be. Another Big Bang belief is that red shift measures velocity – the larger the red shift, the faster it's receding from us.

The Big Bang's Hubble law places the quasar billions of light years beyond the galaxy, because of its much larger red shift. Yet the galaxy is opaque, so it must be near the dust surface or even in front of it! There is also a bright triangular jet of disturbed gases, with the wide end on the galaxy nucleus and the thin end pointing at the quasar. The gas turbulence indicates that something large and powerful has been ejected from the nucleus. The region near the quasar is glowing with extra emission lines from ionized gases. The only candidate for the ejecta is the misplaced quasar.

Halton Arp has been gathering Big Bang discordant redshift evidence since the late 1960's. He has found 20 ultra luminous X-ray sources (like the quasar pictured above) that also have red shifts much higher than the galaxy to which they are physically connected. So, if astronomy were a logical science, wouldn't this evidence mean the end

¹³⁵⁵ <http://upload.wikimedia.org/wikipedia/commons/thumb/1/14/Redshift.png/200px-Redshift.png>. Licensed under GNU 1.2

of the Big Bang? The paper was barely noted when presented to the American Astronomical Society meeting in January 2004. As of April 2006, it still awaits the heavy editing recommended by the peer review committee. Isn't it time for Big Bang theory to retire? Shouldn't astronomy be an adventure in the discovery of truth rather than cutthroat competition for funding?

Description:

Redshift surveys include the first, the CfA Redshift Survey, 2dF Galaxy Redshift Survey, Sloan Digital Sky Survey and DEEP2 Redshift Survey. The Big Bang theory defines the size, the shape and the age of the universe as an expanding sphere 78 billion light years in diameter and 13.7 billion years old. Faith in Hubble's law has distorted most of the distances to galaxies, quasars, and gamma ray bursts.

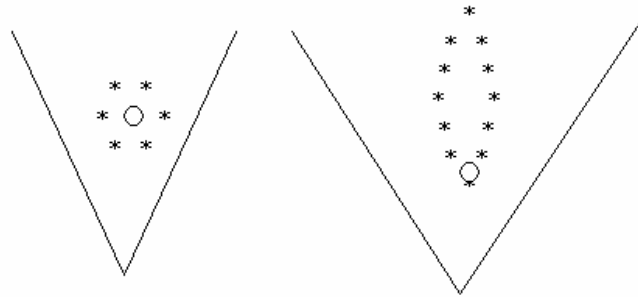

Red shift survey slices: Arp and Big Bang models of the universe

Halton Arp's research shows that redshift cannot be a linear measure of distance. The diagrams above each show a slice of the sky, with Earth always at the center. Arp's view (left) is matched with the Big Bang (right). The size of the dots represents the galaxies' size, but the redshift is inversely proportional to size, i.e., the large central galaxy has the lowest redshift. At the edges are the quasars, the high redshift objects. The Big Bang image at the right shows the distortion of the galaxy cluster produced by Hubble's law, that is, a circle/sphere in reality becomes an elongated bubble. Every cluster in the sky forms these fingers of God aimed at us from everywhere in the sky.

Without the Hubble distortion, the age and size of the universe is unknown, because we can't project backwards in time to the Big Bang explosion. Most objects are closer than once thought, but now there is no universal yardstick. We are back on square one; everything is unexplored and up for grabs. But at least we know what is not true – the Big Bang.

Claims and Responses:

Claim #1: The *Fingers of God* effect that causes clusters to be elongated toward the observer is caused by a Doppler shift associated with the

peculiar motion of the cluster galaxies. Gravity in the cluster causes large velocities that change the redshifts of the galaxies. The Hubble Law relationship is affected, leading to inaccurate distance extrapolation.

Response: When it suits the Big Bang model, redshift data is taken as one number. When a single number presents a problem for Big Bang, then the redshift is split into a cosmic component for the expansion of space and a proper component within the expanding space for the object's velocity. The reasoning above adds a third meaning to the redshift mix – cluster gravity – another escape hatch when geocentrism is implied. No doubt there will be more creative additions in the future.

Claim #2: A similar illusion, the Kaiser effect, is caused, not by random internal motions of the cluster, but by coherent motions of galaxies collapsing towards the cluster center during assembly. This affects the largest scale structures.

Response: See prior comment – you can't say you weren't warned.

Gamma ray bursts (2006):

Visual Gallery of Gamma Ray Burst Observations:

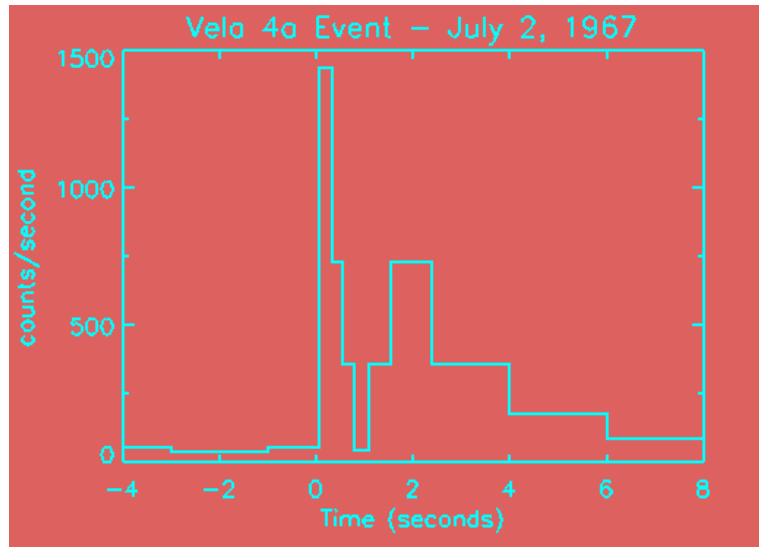

Intensity pattern of first Gamma-Ray Burst¹³⁵⁶

Gamma-Ray Bursts (GRBs) were discovered by accident forty years ago. The Vela satellites were developed to monitor nuclear test ban treaties. Their sensors watched for brief x-ray and gamma-ray flashes, the telltale signatures of nuclear explosions. The Velas did find flashes of gamma rays, as designed, but they were coming from deep space. Data plotted (see above) show that the gamma count rate sharply jumped from the cosmic gamma-ray bursts. These phenomenal bursts of radiation originated from the observable ends of the known universe. Dramatic though the discovery of Gamma Ray bursts was, there is nothing particularly rare about them since they were, and continue to be spotted at a rate of around one a day.

Gamma Ray Bursts are of extremely short duration and fall into two categories; one lasts less than a second, the second about 30 seconds.

¹³⁵⁶ http://antwarp.gsfc.nasa.gov/apod/image/0007/firstgrb_vela4.gif. Credit: R. Klebesadel, I. Strong & R. Olson (LANL), Vela Project

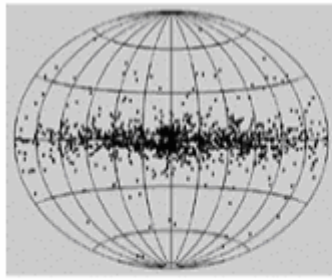

Expected

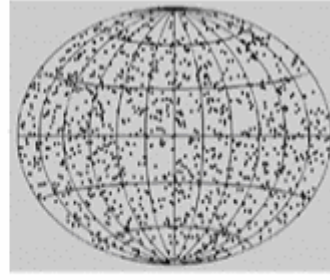

Observed

Distribution of Gamma Ray Bursts in the Sky¹³⁵⁷

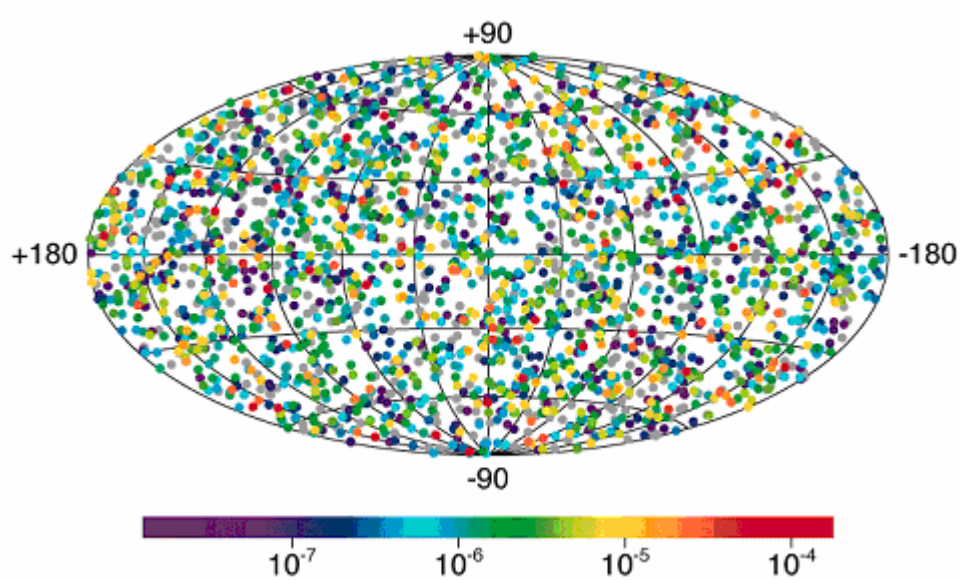

2512 BATSE Gamma Ray Bursts¹³⁵⁸
(Credit: CGRO BATSE Team)

If Gamma Ray Bursts were from the Milky Way, then the furthest and faintest ones would be seen towards the Galactic plane and center. BATSE satellite surveillance found that every category of Gamma Ray Burst, whether chosen by flux, fluence, hardness, duration, or any other parameter, is distributed isotropically.

¹³⁵⁷ http://www.astronomy.csdb.cn/heasarc/docs/objects/grbs/grb_distributions.gif

¹³⁵⁸ http://agile.gsfc.nasa.gov/Images/objects/heapow/transients/batse_bursts.jpg

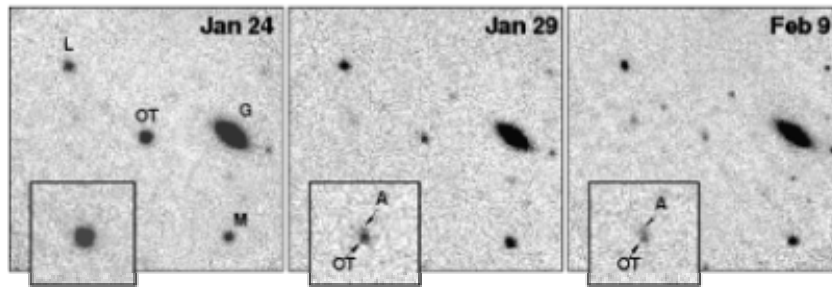

Evolution of a Gamma Ray Burst (NASA)

In the January 24 image, the flash of the optical transient (OT) associated with the Gamma Ray Burst dominates the host galaxy image (A); by January 29, the galaxy has been resolved from the OT. The February 9 image shows the OT fading.

Although a Gamma Ray Burst only lasts for a few seconds, the afterglow can linger for weeks or even months. The afterglow follows a descending path of energy loss, through X-rays down to radio waves. Because the afterglow is much longer-lived than the initial explosion, it may be studied at leisure, without time pressure. By watching the fading of the optical remnants of Gamma Ray Bursts, astronomers concluded that the explosions were embedded in faint galaxies.

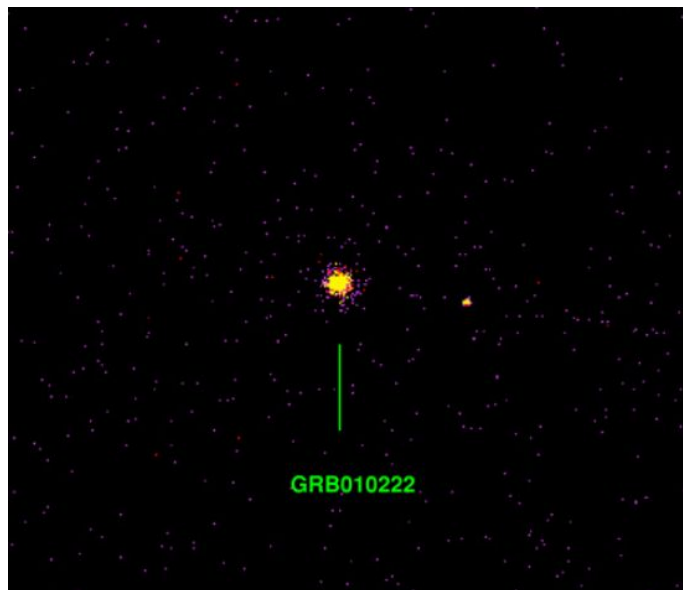

GRB010222: Gamma-Ray Burst, X-Ray Afterglow ¹³⁵⁹
Credit: L. Piro (CNR) et al., CXC, NASA

¹³⁵⁹

http://heasarc.gsfc.nasa.gov/Images/objects/heapow/transients/chandra_grb010222.jpg

A fading afterglow in a false color image is shown from the Chandra X-ray Observatory. GRB010222 was visible for only a few seconds at gamma-ray energies, but its afterglow was observed for days by x-ray, optical, infrared and radio instruments. The x-ray glow, hours after the initial explosion, suggests an expanding fireball moving at near light speed hitting a wall of relatively dense gas. The cosmic blasts may be hypernovae – the death explosions of very massive, short-lived stars.

GRB 990123: Optical Transient Discovery

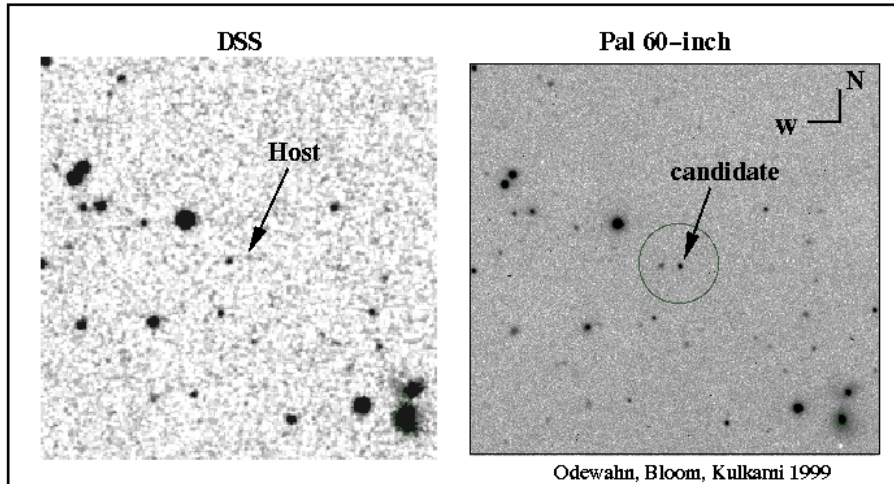

4' x 4'

Galaxy And Gamma-ray Burst¹³⁶⁰

Credit: Courtesy J. S. Bloom (Caltech-CARA-NRAO GRB)

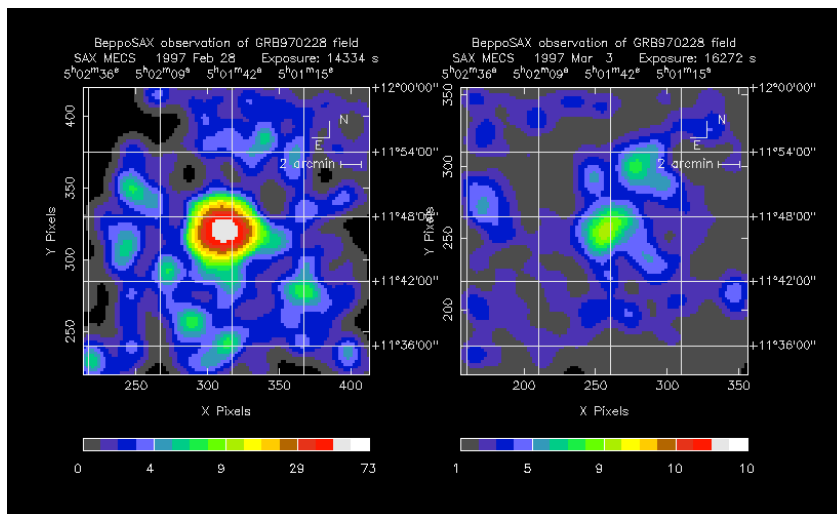

GRB Afterglow¹³⁶¹

¹³⁶⁰ http://antwrp.gsfc.nasa.gov/apod/image/9901/grb990123_compare.gif



GRB 990510: Another Unusual Gamma Ray Burst¹³⁶²

Credit: J. Kaluzny (Warsaw U. Obs.) et al., 1-meter Swope Telescope

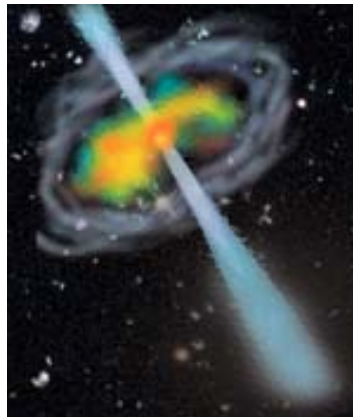

Conception of a Gamma Ray Burst beam¹³⁶³

A beamed explosion is directed like a flashlight, while an isotropic explosion is dispersed outward like the emission from a light bulb. It appears to dim much more rapidly than isotropic light. If gamma-ray bursts are beamed, the energies we are seeing are less than thought, but that also means there are more of them that we don't see. If the explosions are beamed in just one direction, only those observers located along the path of the beam would see them. That means there could be

¹³⁶¹ http://bepposax.gsfc.nasa.gov/bepposax/first/grb_970228.gif

¹³⁶² http://antwrp.gsfc.nasa.gov/apod/image/9905/grb990510_lc1.jpg

¹³⁶³ http://agile.gsfc.nasa.gov/Images/objects/grbs/grb_art_small.jpg

gamma ray bursts exploding all the time, but because the beams are focused in other directions we don't see them. Regardless of whether or not we see the beams of gamma rays, we would still be able to see their afterglows, because afterglows are always isotropic. So, if we find afterglows without seeing the initial bursts, this would prove Gamma Ray Burst explosions are beamed. This is not the case. Afterglows are always associated with Gamma Ray Bursts; Gamma Ray Bursts are isotropic – not focused.

Gravitomagnetic London Moment (2006):

Scientists have measured the gravitational equivalent of a magnetic field for the first time in a laboratory. The effect is much larger than expected from General Relativity. Martin Tajmar and colleagues have measured a new effect, named the Gravitomagnetic London Moment, with a ring of superconducting material rotating up to 6,500 times a minute. Spinning superconductors produce a weak magnetic field, the so-called “London moment.” The new experiment tests whether a gravitomagnetic field will appear in the spinning superconductor. Small acceleration sensors placed close to the spinning superconductor recorded an acceleration field outside the superconductor that appears to be produced by gravitomagnetism.

This experiment is the gravitational analog of Faraday's electromagnetic induction experiment in 1831. It demonstrates that a superconductive gyroscope is capable of generating a powerful gravitomagnetic field, the gravitational counterpart of the magnetic coil. Although it is just 100 millionths of the acceleration due to the Earth's gravitational field, $10^{-4}g$, the measured field is a shocking one hundred million, trillion, times larger (10^{14}) than Einstein's General Relativity predicts. The researchers were reluctant to believe their own results:

We ran more than 250 experiments, improved the facility over 3 years and discussed the validity of the results for 8 months before making this announcement. Now we are confident about the measurement...

says Tajmar, who hopes others will verify the results that challenge current General Relativity theory thinking.

Part 3

There are 3 modernist anti-geocentrism claims:

- (a) The rotation of the Earth
- (b) The revolution of the Earth around the sun
- (c) The sun and Earth participate in the straight line motion of the celestial clusters it belongs to.

This section covers the claim that the Earth is moving in a straight line as part of some cosmic group: the solar system, the Milky Way galaxy, the Local Group of galaxies or some higher hierarchical group.

We start with the Sagnac experiment which first established relative ether motion. The experiments continue up to the latest discoveries based on laser interferometry and analysis of the Cosmic Background Radiation spectrum.

Key ether drift experiments have been revisited by:

- Munera (1998)
- Cahill (2000)
- Allais (1970-2003)
- Galaev (1998)

For experiments not performed in vacuo or with a solid transparent medium, further analysis shows three common features:

1. the definite existence of the ether → non zero fringe shift
2. motion of the ether at less than 10 km/s, from the raw data
3. motion of the ether at less than 10 km/s, from the raw data
4. the direction of the ether flow perpendicular to the ecliptic (the orbital plane of the Sun and planets)

The experimental results are typically cast as “null,” since the scientists were seeking a phantom – an orbital velocity of 30 km/s, when there is no orbit for Earth. The most recent series are those conducted in the Ukraine, using microwaves (1998/99) and optical interferometer methods (2001/2002) (Galaev).

OWLS vs. TWLS:

A two way light speed (TWLS) test occurs when light has to be reflected back on itself to complete a measurement over a set distance. This masks any anisotropy effect by making it a second-order test of v/c . The Michelson-Morley experiment requires sufficient precision to sense

$(v/c)^2$, but a one-way (OWLS) test would be first-order and involve sensing v/c .

Vacuum Interferometers:

Vacuum-mode interferometers have found increasing popularity in modern experiments. Their consistency in obtaining null results for ether drift detection and thus supporting Special Relativity theory may be one of the reasons for this. No one (except Cahill) seems to have asked why gas interferometers consistently detect small speeds of 10 km/s or less, while vacuum versions find no ether motion. An absolute reference frame is indicated by gas interferometers. A theory explaining this must embrace refraction effects to be successful.

Solid Medium Interferometers:

The value of refractive index n in transparent solids is much greater than in gases, leading to the obvious consideration of using solid-state fibers as the light path medium in interferometry. But this extension overlooks the most significant difference between gas and solid – the degrees and types of kinetic freedom. Gas has the most freedom and least resistance to ether effects, as already seen. But atoms in a solid lattice are restricted severely to modes of material vibration about a cell center. We would expect from this (crude) reasoning that light speed would not be affected as much, or at all, compared to propagation of phonons in the transparent fiber. Null results for light speed changes are the theoretical expectation, but a clever experimenter should be able to devise a test for changes in phonon speed or wavelength that are induced by the ether motion. Until a valid theory for ether effects in solids is developed, or more sensitive technology, solid medium tests will have the same status as the vacuum type of interferometry – ineffective for measuring ether drift.

[Key: ✓ = supported; 0 = neutral or does not apply; X = disproof]

[G = Geocentric; H = Heliocentric; E = Ether;
S = Special Relativity; R = General Relativity]

Experiment	Type	G	H	E	S	R
<u>Dayton Miller 1921</u>	A laborious and precise repetition of the Michelson-Morely experiment, with observations taken over a decade, at high altitude with large insulated and non-magnetic interferometers. Claim of ether detection disproved by Shankland.	0	0	0	✓	0
Geocentric Response	Proposed a modified ether model of partial drag/entrainment. Obtained	0	0	✓	X	X

Experiment	Type	G	H	E	S	R
	positive results for a net ether drift of about 10 km/s towards the galactic North pole. This daily or seasonal effect destroys the foundation of the theory of Relativity.					
Illingworth 1972	A Michelson interferometer employing helium as the medium, hoping to reduce thermal variations due to n . Originally reported no ether drift, accurate to about 1 km/s. -----					
Joos 1930	Intended to be a large vacuum interferometer, leaky equipment seals caused conversion to helium, chosen for its low refractive index, less than air. Small fringe shift showed a speed of only 1.5 km/s.	0	0	X	✓	0
Response	Both Illingworth and Joos found similar results with helium. The change in n from air to helium confirmed the refractive index dependence, agreeing with the Michelson-Morely experiment and Miller about an absolute cosmic motion around 400 km/s.	0	0	✓	X	X
Pound-Rebka 1959	Demonstrated that a beam of very high energy gamma rays was slightly red shifted as it fought gravity and rose up a 22 meter elevator shaft at Harvard. The redshift predicted by General Relativity theory of two parts in a thousand trillion (2×10^{-15}) was detected to within one percent (1%) of the computed value. In the reverse direction the gamma waves were blue-shifted to a higher frequency so that the Mossbauer resonant absorption was reduced. The amount of shift in the wavelength corresponded directly to that predicted by General Relativity theory. Both modes show the validity of the Equivalence Principle.	0	0	X	✓	✓
Response	The Hatch scale predicts a change in c that also predicts the measured frequency shift and agrees with the Equivalence Principle to first order. The Pound-Rebka result thus supports both General Relativity theory and Geocentrism (and many others).	0	0	✓	0	0

Experiment	Type	G	H	E	S	R
Jaseja 1963	Two He-Ne masers mounted with axes perpendicular on a rotating table produced a consistent interference pattern. Cited as yet another “null” result for absolute motion testing.	0	0	X	✓	0
Response	A fringe pattern dip occurs at a sidereal time agreeing with the Miller cosmic direction. Unfortunately, without knowing the ratio of He to N, the exact value of n cannot be used to predict the actual ether speed. This test failed in two ways: (1) omitted the refraction correction, (2) no comparison was made with Miller’s long-term data (5 years earlier) in sidereal time.	0	0	✓	X	X
Spinning Mossbauer disc Champeny 1963	One Way Tests of Light Speed with Mossbauer effect. Uses a rotating gamma ray source and fixed detector at the center of rotation to place an upper limit on any one-way anisotropy of 3 m/s. Reverses the light path direction by using a rotating source and fixed gamma ray detector at the center to place an upper limit on any one-way anisotropy of 10 m/s. Both spinning Mossbauer experiments use a one-way light path to confirm isotropy of light speed. They are strong evidence in support of Special Relativity by validating the claim of isotropic light speed in every inertial frame by showing that there is no detectable ether drift in the laboratory.	0	0	X	✓	0
Turner/Hill 1964						
Response	Only in 2002 was the Michelson-Morely principle of operation understood; its proper analysis leads to rejection of Special Relativity theory in support of Geocentrism. Vacuum interferometers are worthless for detecting ether drift. Only gas Michelson interferometers can detect absolute motion. The drift speeds measured are similar to the Miller and corrected Michelson-Morely experiment. Should have been repeated in vacuum, to verify a true null result.	0	0	✓	X	X
Shamir/Fox 1969	Repeat of the Michelson-Morely experiment with He-Ne laser and plexiglass ($n = 1.49$) wave guides 0.26 long. Interpreted in terms of the Fresnel	0	0	X	✓	0

Experiment	Type	G	H	E	S	R
	drag and Lorentz contraction effects. Light within the plexiglass was modeled as dragged along with it, adding a speed of $(1-1/n^2)V_{\text{ether}}$ to the speed in the solid, c/n . No shifts were seen on rotation, though sensitivity was .00003, setting an upper limit on ether drift to 6.64 km/s. Conclusion: negative result “enhances the experimental basis of Special Relativity.”					
Response	The use of solid media to detect absolute motion is hopeless, as Miller’s data showed that solids absorb ether. Objectively, as a test of ether motion, this experiment was meaningless.	0	0	0	0	0
<u>Shapiro Venus Radar 1969</u>	Direct test of Einstein’s second postulate and with General Relativity claims that c depended on the strength of the gravitational force along its path, in the 1961 interplanetary radar contact with Venus. The expected time delay, due to the passage close to the Sun, would be about 200 milliseconds. The test was successful.	0	0	0	✓	✓
Response	Bryan Wallace discovered in 1961 that radar distance measurements of the surface of the planet Venus did not confirm the constancy of the speed of light. There were systematic variations in the radar data containing diurnal, lunar and synodic components. Wallace’s analysis strongly challenged the Shapiro reading of results. His analysis of sparsely published 1961 data on the interplanetary radar contact with Venus concludes the data showed a $c + v$ Galilean component.	✓	0	0	X	X

Experiment	Type	G	H	E	S	R
Brillet-Hall 1979	Employed a Fabry-Perot etalon setup with highly accurate lasers and a constant reference length to put an upper limit of 30 m/s for c one-way trips, but reduced this to only 0.000001 m/s for two-way light travel in static or partially entrained ether. Corresponds roughly to the Michelson-Morley experiment (no variations of the round-trip speed of light in different directions, with a time-scale of minutes). Temperature was stabilized inside a vacuum tube. Claimed to impose the most accurate limits on round-trip c anisotropy, since Brillet-Hall found the beat-frequency between a single-mode static laser and its rotating twin limited c anisotropy to 3 parts in 10^{15} .	X	0	X	✓	0
Response	No need to know anything more after the “vacuum” path is mentioned. Without a gas in the path ether interaction is virtually immeasurable – the Cahill criterion. When long term data collected by Brillet-Hall is analyzed it reveals a daily and annual low velocity periodic variation, anticipating confirmation by future tests of higher precision.	✓	X	✓	X	0
Torr/Kolen 1981	Two atomic clocks separated by 500 meters look for sidereal phase variations between them. Guided wave one-way speed-of-light experiment based on the cut-off frequency of a wave guide. Claimed a clear null result for the anisotropy of cosmic radiation that defines a preferred frame of reference.	0	0	X	✓	0
Response	The data clearly indicate a signal of about $0.5 \mu\text{V}$ representing eastward motion. This one-way phase shift disappeared from the complete round-trip measurement, showing that two-way light speed tests can mask changes in c . Showed the ability to sense the speed of a test device using optical speed-of-light sensing in an enclosed room, a very definite disproof of Special Relativity!	0	0	✓	X	X
Throbbing Earth 1983	Gravity-wave detectors in Geneva and Frascati, Italy operating for over a year have recorded ground pulsations, most likely expansions and contractions of the	0	0	0	0	0

Experiment	Type	G	H	E	S	R
	entire Earth. Pulse amplitudes are about 100 times larger than gravity wave expectations, but the key feature is the pulsing period – regularly every 12 sidereal hours, which indicates a stellar origin.					
Response	First, note that this has been known for over two decades, with no experimental follow-up or even proposed theory. Why is this astounding fact a scientific pariah? What sort of cosmic force could make Earth throb with energy with such precise celestial-based timing? Sidereal waves are anathema to the scientific modernist.	✓	0	0	X	X
Silvertooth 1986	A first-order test of a one-way laser beam interfering with a standing wave initiated by the same laser. The standing wave nodes shifted position when the equipment direction was changed. One wave was phase modulated with respect to the other, creating phase differences that were measured with a photomultiplier tube of special design. Silvertooth's results demonstrate that the wavelength of light varies with the direction of its propagation. The experiment was repeated in 1992, with the same results.	0	0	X	✓	0
Response	Silvertooth claimed his interferometer detected the absolute motion of the Earth with respect to the ether. Silvertooth's velocity vector points in a different direction, with twice the speed of Miller's ether velocity, but agrees with Holger Müller's ether velocity. He always found a preferred direction in the direction of the constellation Leo, traveling at a velocity of 378 km/sec. If relativity is correct, then this result should be total nonsense. If the result is correct, however, then it's relativity that is rubbish.	0	0	✓	X	X
DeWitte 1991	Over a six-month period of testing a 1.5km underground coaxial cable, Dewitte found a cyclic component in the phase drift between high-precision cesium-beam clocks. A 5MHz radio frequency signal generated from each cesium time-base produced two independent but identical signals to within	0	0	X	✓	0

Experiment	Type	G	H	E	S	R
	the limits of cesium clock drift. The period proves to be the sidereal day, so DeWitte inferred the cause responsible for the phase shift was galactic, not man-made, in origin.					
Response	No feedback from Relativists yet; it may be that the results are too new, or they are being ignored, or Relativity has no response. Confirms the Miller results with a non-interferometer experiment. Using the Fresnel drag correction predicts an ethereal speed of 900 km/s, far beyond the results of other experiments. This is just another contra-indication of the ether-drag concept, whether partial or total. To repeat this as a two way light-speed experiment, with round-trip measurement to see if a null-result would be obtained due to round-trip averaging, would be enlightening.	0	0	✓	X	X
<u>CMB dipole</u> 1996	NASA's COBE satellite sky-mapping project revealed a dipole temperature anisotropy in the cosmic background radiation (CBR), indicating that the solar system is moving through this unique inertial frame at approximately 390 ± 60 km/s in the direction of Leo. In the CMB rest frame this is one part in 800 (0.13%) of c and more than 10 times the Earth's orbital speed.	0	0	0	✓	✓
Response	If the CMB fills the universe, then its rest frame must be the absolute frame forbidden by Relativity. Why isn't the Big Bang recession of galaxies at much greater speed than the dipole speed detected in the CMB? What makes the cosmic expansion speeds invisible? The dipole shows that the galaxies are not receding but are basically at rest in a radial direction and the Earth is at rest, with the Regulus group approaching us. There is a preferred orientation in space, as seen from Earth. The universe has an absolute reference system, debunking Relativity theories; the cosmological principle is disproved. The CMB dipole was totally unexpected and still	✓	X	✓	X	X

Experiment	Type	G	H	E	S	R
	unexplained by theorists.					
Nodland & Ralston 1997	A statistical computer analysis of astrophysical data shows a systematic rotation of the polarization plane of radio waves depends on the waves' direction and travel distance. The effect is extracted independently from Faraday rotation, and found to be correlated with the angular positions and distances to the sources. Monte Carlo analysis yields probability 10^{-3} for the axis to be a random fluctuation. Dependence on redshift rules out a local effect. Barring a hidden systematic bias in the data, the correlation indicates a new cosmological effect.	0	0	X	✓	0
Response	“Indication of anisotropy in electromagnetic propagation over cosmological distances” is a well-done article reporting a systematic angle difference between the polarization of radio waves from distant galaxies and the long axis of the elliptical optical images from those galaxies. The polarization axis passes through the Earth from Serpens to Aquila, supporting the Earth's central position in the universe. The observed axis is due to the ether flow.	✓	X	✓	X	X
CMB quadrupole octopole 2002	WMAP reveals anomalies at the largest angular scales ($> 60^\circ$): (1) the vanishing of the angular two-point correlation function; (2) under-sized quadrupole and octopole moments, both very planar and aligned; (3) all minima and maxima fall on a great circle on the sky; (4) the low multipoles are inconsistent with a Gaussian normal distribution; (5) they have strong correlation with the solar system ecliptic and the CMB; (6) all patterns have a high level of statistical significance ($>99\%$); (7) becoming more likely that the large scale microwave sky has a local cause.	0	0	X	✓	0
Response	So, the latest CMB analysis shows unexpected correlations of low multipoles with the ecliptic and galactic plane! The measurement does not agree with the generic prediction of a random, statistically isotropic sky from Big Bang	✓	X	✓	X	X

Experiment	Type	G	H	E	S	R
	inflation theory. Instead, there is a totally unexpected symmetry for what should be a map of the cosmos, not of the local structures. This finding is non-trivial, casting doubt on the standard cosmic interpretation of the lowest- l multipole correlations from the sky map temperatures. Uncertainty also surrounds the Big Bang claim that the first stars formed very early in the history of the universe.					
Galaev 2002	Light speed experiment to first order in v/c , based on viscous gas movement in tubes.	0	0	X	✓	0
Response	Ether verification and measurement of velocity and viscosity with millimeter radio waves, by the gas phase method. Demonstrates ether exists, is dynamic, has viscosity, a cosmic source, and depends on latitude and altitude. Earth exhibits NO orbital motion. Simply put, virtually all these results conflict with Special Relativity and General Relativity theory. No response by Relativists to this recent disproof has been published yet.	0	0	✓	X	X
Pioneer 10,11 anomaly 1972-2004	The speed of light in deep space may not be c , based on the Pioneer probes. Their radio signals contain an “anomalous” Doppler shift, attributed to a small constant acceleration sunward. The drift is a blue shift, uniformly changing with a rate of $\sim (5.99 \pm 0.01) \times 10^{-9}$ Hz/s, or 8.0×10^{-8} cm/sec ² . direction: a line-of-sight constant acceleration toward the sun. distance: from ~ 20 to 70 AU from the sun.	X	✓	X	✓	0
Response	The annual effect is particularly large in the excursion of Pioneer 11 out of the ecliptic plane! This is a rare opportunity to measure the ether flow outside the ecliptic. The increase in the Pioneer acceleration supports ether flow theory. The effect is due to the varying ether as the transition is made from Newtonian gravity near Earth to the intense firmament of deep space. If the anomalous radial acceleration acting on	0	0	✓	X	X

Experiment	Type	G	H	E	S	R
	spinning spacecraft is gravitational in origin, it is not universal. It must affect bodies in the 1000 kg range more than bodies of planetary size by a factor of 100 or more, a violation of the Principle of Equivalence.					

Dayton Miller:

To test the ether drag hypothesis, Miller repeated the Michelson-Morely experiment by moving it from a Cleveland basement to higher ground on Mount Wilson, where ether drift should be stronger. Miller's data was far more precise and prolific than the Michelson-Morely experiment. His larger apparatus used a 50x telescope, allowing magnified readings down to hundredths of a fringe, though readings were typically recorded in tenths. To detect anisotropies in the speed of light, the interferometer needed to be surrounded by as little matter as possible, and located at a high altitude – a precaution ignored in many modern ether tests, such as the Brillet-Hall and Müller experiments. Detection of an ether wind was virtually impossible if it was almost completely blocked out by surrounding structures like the laboratory walls or the apparatus itself. To avoid the ether wind being blocked by solid walls, he used a special shed with thin walls, mainly of canvas. Miller argued that basement locations, or interferometers shielded with opaque wood or metal housings, yielded the most tiny and insignificant effects, while those undertaken at higher altitudes and in less dense structures yielded more readily observable effects.

Michelson-Morely vs Miller:

A total of over 200,000 individual readings were made, from over 12,000 individual turns of the interferometer, undertaken at different months of the year, starting in 1902 and ending in 1926. The Michelson-Morely experiment of 1887 involved only six hours of data collection over four days with only 36 turns of their interferometer. Even so, Michelson-Morley originally obtained a slight positive result that has been systematically ignored or misrepresented by modern physics. The Michelson-Morely experiment was performed in a basement, violating almost all of Miller's rules for ether detection and avoiding material dragging. Miller thought shielding of the apparatus by this interior location slowed down the movement of the ether. A small but practically "null" result for any similar Michelson-Morely type was virtually guaranteed. Michelson and Morley's "null" result appears to have been conducted in ignorance of Miller's work and protocol caveats. They

seem to have been unaware of Miller's conclusion that the ether wind can best be detected in the open.

Miller's analysis showed that the Michelson-Morely experiment did, in fact, contain a systematic sine wave of readings as expected of an ether drift. The commonly accepted null result is only arrived at by assuming a specific direction for the ether wind, combined with disregard for thermal effects. When daily temperature drift is factored out and no wind direction assumed, the 1887 Michelson-Morely experiment shows a fringe shift approximately equivalent to the 10 km/s found in Miller's experiments. Concerning the Michelson-Morely experiment Dayton Miller concludes that:

The brief series of observations was sufficient to show that the effect did not have the anticipated magnitude. However, and this fact must be emphasized, the indicated effect was not zero; the sensitivity of the apparatus was such that the conclusion, published in 1887, stated that the observed relative motion of the earth and ether did not exceed one-fourth of the Earth's orbital velocity. This is quite different from a null effect now so frequently imputed to this experiment by the writers on Relativity.

Geocentric Response:

Miller consistently measured a small positive effect that varied with each rotation of the device in a sidereal day and on a yearly basis. This effect was only ~10 km/s instead of the expected ~30 km/s from the Earth's orbital motion through a rigid stationary ether. The reduction was attributed by Miller to partial dragging of ether. The Fitzgerald-Lorentz contraction derived from Special Relativity invariance of c was consistent with the apparently null results of most Michelson-Morely experiment types, but not with Miller's observed seasonal effects. Miller's concern about the experiment's ambient conditions was justified, but not because ether was dragged by the environment.

In Geocentrism:

1. The Earth doesn't move in the ether vortex surrounding it
2. Genesis testifies that the firmament only exists above sea level, so the Earth's surface forms its boundary.

A few years after Miller's death his work was reportedly refuted by Shankland, a personal friend and great admirer of Einstein, but recent objective work by Maurice Allais has proven the allegations false. Miller's experiments were found to have no fundamental error; observations all show a positive periodic displacement of the interference fringes, as of an ether drift. The effects were shown to be real and systematic, beyond any further question. Miller had better

knowledge of these experiments than any commentator/critic. Nevertheless, the opinions of armchair scientists from the sidelines tend to be more credible than the views of those actually involved daily in the research. The current image of science is a kind of democracy where agreement signifies truth while disagreement is taken to imply incompetence, or bias, or political interference.

Einstein and Miller:

Einstein personally played a part in dismissing Miller's work, knowing that supporting it would end his Special and General Relativity theories. He felt Miller's results could be dismissed as experimental error. In 1926 Miller told the press:

The trouble with Professor Einstein is that he knows nothing about my results....He ought to give me credit for knowing that temperature differences would affect the results. He wrote to me in November suggesting this. I am not so simple as to make no allowance for temperature.

Cosmic ether drift:

The experiments yielded systematic periodic effects that pointed to an identifiable axis of cosmic ether drift, though of a variable magnitude, depending upon the season, time of day, density of materials shielding or surrounding the apparatus, and altitude at which the experiment was undertaken. Ether properties explain all these variable dependencies. When data were plotted against sidereal time, they produced:

a very striking consistency of their principal characteristics...for azimuth and magnitude... as though they were related to a common cause...The observed effect is dependent upon sidereal time and is independent of diurnal and seasonal changes of temperature and other terrestrial causes...a cosmic phenomenon. (Miller 1933)

Since the measurements were made at different times of day, and at different seasons, their amplitude would vary, but the direction of the ether-drift would shift only to the same average points along a sidereal azimuth. Measurements were latitude-dependent as well, and when analyzed, revealed a common sidereal cosmological axis of ether-drift.

Miller concluded that the Earth was drifting at about 10 km/sec towards an apex in the Southern Celestial Hemisphere, towards Dorado, the Swordfish, right ascension 4 hrs. 54 min., declination of $-70^{\circ} 33'$, in the middle of the Great Magellanic Cloud and 7° from the southern pole of the ecliptic. He assumed the Earth was moving through a partially

entrained ether which reduced its velocity from 200 km/sec in space, to about 10 km/sec nearer to the surface. This experimental result agrees with the concept of partially entrained ether but not with Special Relativity theory.

Independent averages for the four epochs provided by Miller (February = -10° west of north; April = $+40^\circ$ east; August = $+10^\circ$ east; September = $+55^\circ$ east), together yield a grand mean displacement 23.75° east of north. This is very close to the Earth's axial tilt of 23.5° , a correlation hardly coincidental.

Summary of cosmic drift results:

- Maximum velocity occurs at around 5 hours sidereal time and minimum velocity occurs around 17 hours sidereal.
- The movement and direction of ether drift past the interferometer was towards Draco near the northern pole of the ecliptic (17 hours RA, Dec $+68^\circ$).
- Efforts to correct for mechanical and thermal artifacts never eliminated the observed periodic sidereal variations, which persisted throughout the experimental work.

Data Analysis:

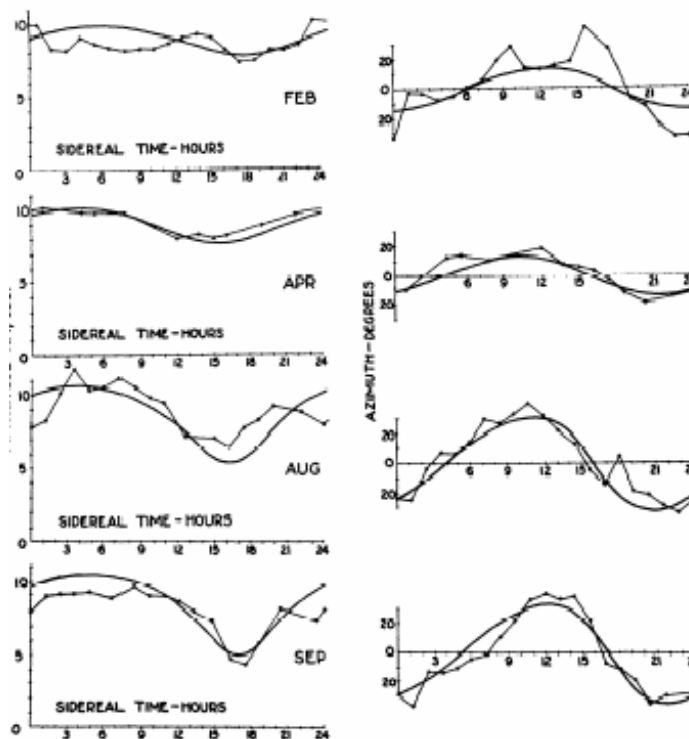

Periodicity of Global Ether-drift, Dayton Miller 1925-26.

The above-left chart shows a definite periodic curve for four separate months, measured at different sidereal times. The heavy line is the mean of all four epochs. The above-right chart plots the azimuth for the same data with apparent visual periodicity. This demonstrates the detected axis and periodicity of ether drift is the same for different times of year, but is only recognizable visually in a sidereal view. There never were any periodic effects seen in civil time coordinates, as expected from daily thermal effects arising from solar heating.

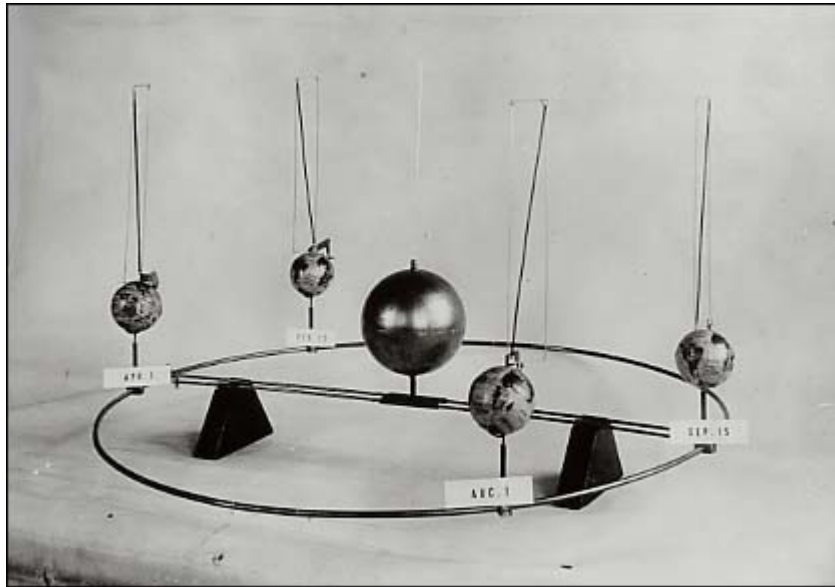

Miller's Earth-Sun model, measured at four seasons, for the cosmic ether-drift axis, approximately normal to the ecliptic plane

Analysis by Allais:

Maurice Allais performed a statistical analysis of the thousands of interferometer measurements of Dayton Miller and found a corresponding periodicity with the sidereal day, the equinoxes and other celestial events. According to Allais:

- Michelson and Morley results were not null, invalidating both Shankland's report and Special Relativity.
- Anisotropy of light was seen as variations in light speed with direction, implying an underlying universal frame.
- Determination of day of year was possible with terrestrial measurements – for example, in a sealed room.
- The Earth's cosmic translation velocity had a computational error in direction.
- Fringe variations have a sidereal period.
- Fringe extrema coincide with the equinoxes.

- The data has a high confidence level and statistical significance.
- No distinction exists between Earth's rotation and translation, as Special Relativity asserts.
- Both rotation and translation are detectable.

Illingworth:

Munera revisited the data, getting $V_e = 3.1$ km/s. For helium $k^2 = 0.00007$, greatly reducing sensitivity, but providing the first experiment to use a gas other than air, as was done in the Michelson-Morely experiment and Miller. The dependence on refractive index was now testable, albeit in hindsight 80 years later. The correction factor for helium is 118, so $V_{ae} = 368$ km/s, in the ballpark of the Michelson-Morely experiment and Miller ether velocities, as corrected for refractive reduction.

Joos:

Joos concluded that the small interferometer fringe shift showed a speed of only 1.5 km/s. The corrected speed for fringe shift with helium refraction is 433 km/s.

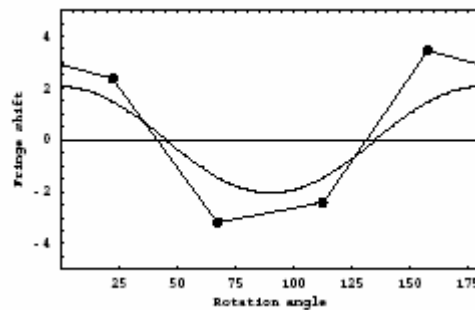

Comparison of Joos data with theoretical Miller curve¹³⁶⁴

NB: The ether has a yearly cycle centered on the galactic North pole!

Pound-Rebka:

Definition: Principle of Equivalence:

Experiments performed in a reference frame with constant acceleration are equivalent to the same experiments performed in a non-accelerating reference frame in a gravitational field where the

¹³⁶⁴ http://xxx.lanl.gov/PS_cache/physics/pdf/0312/0312082.pdf

acceleration of gravity, g , equals the intensity of gravity field. This implies that the gravitational mass used in Newton's universal law of gravitation is identical to the inertial mass in Newton's second law, $F = ma$. Also, because photons have momentum, they have inertial mass and gravitational mass. Photons should be deflected when crossing radial gravity lines and impeded when moving opposite to gravity. The last implication is tested by looking for a gravitational redshift, as Pound-Rebka did.

Description:

The last of the classical tests of General Relativity to be verified in 1959. It uses the redshift of light moving in a gravitational field to test if clocks do run at different rates at different altitudes. The frequency of photons emitted by two iron (Fe^{57}) sources were compared at a fixed location twenty-two meters apart. The source was mounted on a speaker cone vibrating at 10 Hz to mechanically drive the source up and down slightly. By measuring the variation in detection rate of the Fe gamma rays while the source vibrated, the velocity difference between source and detector that compensated for the gravitational frequency shift could be found. By reversing direction to also measure the frequency shift of rising gamma rays, the difference between the rising and falling effects was measured – only a few parts in 10^{15} . This represented the pure gravitational effect. An ingenious experimental design.

Analysis:

According to the principle of equivalence from General Relativity, acceleration of a radiating source produces the same frequency effects as a corresponding gravity field. Thus the expected shift in radiation frequency in a gravitational field can be related to the relativistic Doppler shift experienced from an accelerating light source. The maximum source velocity v is $\ll c$; the frequency of the gamma source at rest is f_0 .

For a moving source the Doppler formula for detected frequency f is:

$$f = f_0(1 + v/c)$$

The time to reach the detector is:

$$t = L/c$$

and the speed is:

$$v = at = a(L/c) = gL/c$$

by the principle of equivalence. The detected frequency is now:

$$f = f_0(1 + v/c) = f_0(1 + (gL/c)/c) = f_0(1 + gL/c^2)$$

so:

$$\Delta f = f - f_0 = gL/c^2$$

The variations of $v(t)$ affect the frequency f according to the strength of gravity g . In Special Relativity:

$$E = mc^2 = hf$$

And the gravitational potential energy at reference radius r_0 is:

$$U = -GMm/r_0$$

where f_0 is the reference frequency of the gamma rays. At altitude h :

$$U = -GMm/(r_0 + h)$$

$$= -GMm/r_0(1 - h/r_0)$$

$$\approx -GMm(1 + h/r_0)/r_0$$

At this height the difference in energy is:

$$\Delta E = \Delta U = h\Delta f$$

$$= -GMm/r_0 - (-GMm/r_0 - GMmh/r_0^2)$$

$$= GMmh/r_0^2 = mgh = h(f_0 - f)$$

f is the frequency at h , so:

$$\Delta E = mgh = Egh/c^2$$

$$= 14.4 \text{ KeVg} \times 22.6\text{m}/c^2$$

$$= 3.5 \times 10^{-11} \text{ eV}$$

Comparing the energy shifts on the up and down paths gives a predicted relative difference of:

$$(\Delta e/E)_{\text{down}} - (\Delta e/E)_{\text{up}}$$

$$= 2(3.5 \times 10^{-11} \text{eV})/14.4 \text{ KeV}$$

$$= 4.9 \times 10^{-15}$$

The measured equivalent is:

$$(5.1 \pm 0.5) \times 10^{-15}$$

The Pound-Rebka experiment did not:

- demonstrate a constant speed of light. If c decreases by only 7.35×10^{-7} m/s in the 22 meters above the Earth, the same effect as observed would be seen in the frequency drift. This test alone cannot prove or disprove this possibility.
- show how space and time were unified.
- solve the action at a distance question - the existence of an ether or not.

The results are inconclusive; what it proved was the energy of a photon will change as a function of gravity or equally possible, as a function of the cause of gravity, i.e., ether. When the change in c is calculated from the Hatch gauge scale, we find:

$$V = c (1 - 2gh/c^2)^{1/2} \approx c(1 - gh/c^2)$$

This predicts the same change in c , 7.35×10^{-7} m/s, and frequency, 4.92×10^{-15} , as was measured in the Pound-Rebka test, as long as the coordinate system is geocentric and “h” is measured from the surface.

Claims and Responses:

Claim #1: The gravitational interaction occurs within a four-dimensional space-time continuum that cannot be illustrated by diagrams and can only be understood in terms of very complex Riemannian geometry. Gravity causes “space-time” to curve in a way that cannot be pictured. As the photons move through this curved space, the curvature causes them to be redshifted and blueshifted.

Response: There are no experimental measurements that could serve as evidence for “the space-time continuum,” – a ruler-clock? Belief in General Relativity theory permits (and prefers) mental measurements (gedanken experiments) over physical observations.

Claim #2: Only an observer in free fall, who is weightless and feels no acceleration or gravity, is in an unbiased reference frame.

Response: This contradicts the freedom to choose the inertial reference frame of Special Relativity. If General Relativity theory requires a frame in free-fall, then it is no longer a theory of relativity but absolutivity, since all frames are not equivalent. Satellites satisfy the free-falling condition, yet GPS will not operate if the satellites are used as the time standard!

Jaseja:

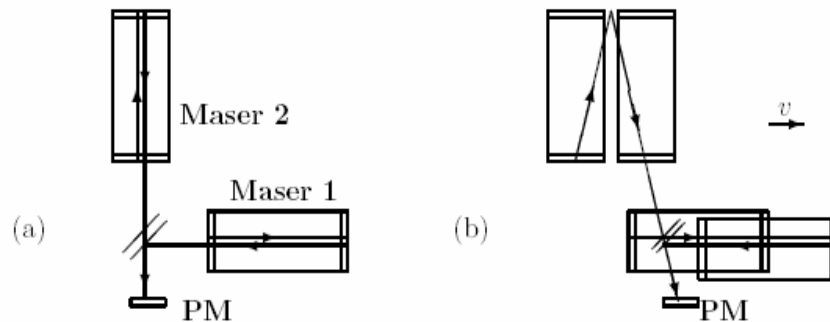

Layout to measure beat frequency between two optical masers:
(a) both at absolute rest, (b) top in absolute motion at velocity v .
PM is the photomultiplier detector.

This double maser apparatus is essentially equivalent to a Michelson interferometer, measuring the ether effect to order v^2/c^2 . Rotation through 90° produced repeatable variations in the frequency difference of about 275 kHz, an effect attributed to magneto-restriction in the Invar spacers due to the Earth's magnetic field. Observations over some six consecutive hours produced a minimum in the frequency difference of about 3 kHz superimposed on the 275 kHz effect.

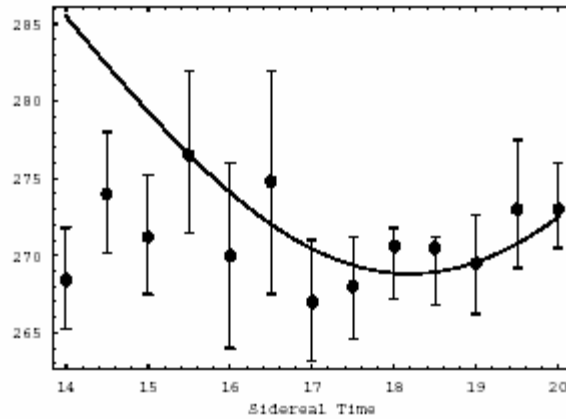

Frequency delta after a 90⁰ rotation

Geocentric analysis:

Seen above, 275 khz is the average frequency shift over time which shows a local drop of 3 khz at 18 hour star time. This is interpreted favorably with the Miller velocity direction, but caution in comparison with regard to Miller's data is warranted here, because of the small fringe size, and the adjustment for orbital velocity and sun ether flow effects. The resonant frequency ν of each maser is proportional to the reciprocal of the out-and-back travel time. Cahill finds the difference between the frequencies of maser 1 and 2 is:

$$\Delta f = 2(f_2 - f_1)$$

In terms of the refractive index n , the rim rotation speed v and the frequency before rotation, f_0 ,

$$\Delta f = (n^2 - 1)f_0 v^2 / c^2 + \text{higher order in } v/c$$

In Newtonian physics one neglects the refractive index effect, so:

$$\Delta f = f_0 v^2 / c^2$$

similar to the classical analysis of the original Michelson interferometer. The very small size of the ether motion fringes results mainly because the n value of the He-Ne gas is very close to one.

Spinning Mossbauer Effect:

The spinning Mossbauer experiments use a one-way light path to confirm isotropy of light speed. They are strong evidence in support of Special Relativity by validating the claim of isotropic light speed in

every inertial frame by showing that there is no detectable ether drift in the laboratory.

Geocentric Response:

Only in 2002 was the Michelson-Morely experiment principle of operation understood; its proper analysis leads to rejection of Special Relativity in support of Geocentrism. Vacuum interferometers are worthless for detecting ether drift. Only a Michelson interferometer in gas-mode can detect absolute motion.

Description:

The Mossbauer effect is both a source and detector of very precise gamma ray frequencies, making it a useful tool to directly detect an ether drift. Experimental setup consists of gamma ray source and detector on a spinning disk, with the light path across either the radius or diameter of the disk. The light direction can be reversed by switching the location of source and detector. Ruderfer gave the transit time across a spinning disk to second order in $1/c$, as:

$$\begin{aligned}\tau &= L/(c-V_{ae}\cos\theta) \\ &= L/c(1- (V_{ae}\cos\theta)/c) \sim L(1 + (V_{ae}\cos\theta)/c)/c \\ &= L/c + LV_{ae}\cos\theta/c^2\end{aligned}$$

Δt = the transit time

L = the distance between source and detector

c = the speed of light

V_{ae} = the local ether frame velocity

θ = the angle of the light path relative to the local ether velocity

The time derivative of τ is:

$$d\tau/dt = LV_{ae}\sin\theta (d\theta/dt)/c^2$$

Then:

$$\Delta f/f \approx \Delta\tau/dt \approx d\tau/dt = LV_{ae}\sin\theta d\theta/dt$$

which represents the change in detected frequency compared to the source f

For the two cases are considered:

- (1) The source located on the spinning rim and detector at the center, as done by Champeny
- (2) the source located at the center and the detector on the spinning edge, as in Turner-Hill

$L \, dq/dt$ is the tangent speed of the rim, V_t , so:

$$\Delta f/f = V_t V_{ae} \sin\theta / c^2$$

If there is no ether drift, there is no frequency drift. Otherwise the frequency change is given by this formula. However, both Ruderfer and Hayden¹³⁶⁵ have shown that the frequency change due to ether wind is canceled by an equal and opposite transit time effect, i.e., the delay of the beam in moving from source to detector:

$$V_t V_{ae} \sin\theta / c^2$$

The bottom line: the spinning disk experiment using the Mossbauer effect is incapable of detecting any ethereal motion, as the effect is masked by another effect of motion.

Geocentrism view:

Reginald Cahill has revisited the Michelson-Morely experiment, for a fruitful re-analysis of the underlying theory. For the difference in travel time between the two Michelson-Morely legs, and explicitly including air refraction using $V = c/n$ for the speed of light in air, he finds:

$$\begin{aligned} \Delta t &= 2Lv(1 - v^2/c^2)^{1/2} / (V^2 - v^2) - 2L/(1 - v^2/c^2)^{1/2} \\ &= 2Lc(1 - v^2/2c^2 + O(v/c)^4)n^2(1 + n^2v^2/c^2 + O(v/c)^4)/nc^2 \\ &\quad - 2Ln(1 + n^2v^2/2c^2 + O(v/c)^4)/c \\ &\approx 2Ln(1 - v^2/2c^2 + n^2v^2/c^2 - 1 - n^2v^2/2c^2)/c \\ \Delta t &= n(n^2 - 1) Lv^2/c = k^2Lv^2/c \end{aligned}$$

defining the corrected $k^2 = n(n^2-1)$ to make comparison with the classical prediction of Newtonian optics that $k^2 = n^3$. For a vacuum interferometer

¹³⁶⁵ Ruderfer, Martin, (1961) "Errata First-Order Terrestrial Ether Drift Experiment Using the Mossbauer Radiation," *Physical Review Letters*, Vol. 7, No. 9, 1 Nov., p 361.
Hayden, Howard C. (1992) "Rotating Mossbauer Experiments and the Speed of Light," *Galilean Electrodynamics*, Vol. 3, No. 6, Nov.

$n = 1$, so all Michelson-Morely type experiments will never detect a time dilation! Classical theory says $n = k = 1$ in vacuum, and the time difference will be:

$$\Delta t = Lv^2/c$$

The relationship $k^2 = n(n^2-1)$ tells us that the:

- ether can only be detected using gas with $n > 1$.
- best medium for this experiment would have a high index of refraction, like chlorine in the following table.

Helium	1.000036
Hydrogen	1.000140
Water vapor	1.000261
Oxygen	1.000276
Argon	1.000281
Air	1.0002926
Nitrogen	1.000297
Carbon Dioxide	1.000449
Chlorine	1.000768
Perfluorobutane	1.0014

Index of refraction n for common gases

However, this would also increase the photon absorption and reduce the beam intensity. Cahill notes that in transparent solids a more complex phenomenon occurs; ether drift effects either do not occur in them or are not yet detectable. The index of refraction for air is $n = 1.0002926$, so $k^2 = n(n^2 - 1) = 0.0005852$, accounting for the small fringe shifts observed by Michelson-Morely. Michelson and Morley did indeed see ether-induced fringe shifts, contrary to conventional science wisdom, as analysis of their data shows. Their measured value of about 8 km/s was reduced by $k = 0.0005852^{1/2} = 0.0242$. To restore the actual value divide by k gives $V_{ae} \approx 330$ m/s for Michelson-Morely and ≈ 410 m/s for Miller's drift velocity.

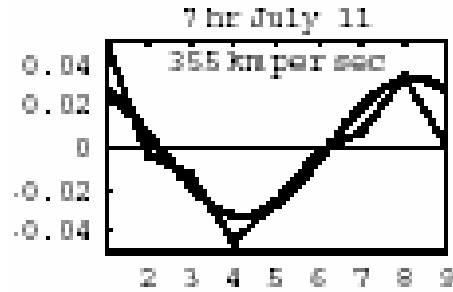

**Sample Michelson-Morely data after refractive
and thermal drift corrections**

In general, the ether velocity V_{ae} can be found from the experimental velocity V_e via:

$$V_{ae} = V_e(n(n^2 - 1))^{-1/2}$$

Recall that 8 km/s was smaller than the presumed orbital speed of 30 km/s. The updated result (after over a century!) was:

- absolute motion had been detected as fringe shifts of the correct form
- k^2 was 0, not 1, a flaw in classical theory.
- the speed of light was relative to a direction in space

It seems counter to intuition that such a small deviation from the refractive index of vacuum (such as .0002926 for air) can have such a huge effect on the detected ether speed. But it becomes more sensible when considering the exquisite optical precision of the interferometer, capable of measuring a partial wave over paths meters long.

Shapiro Venus Radar (1969):

Cyclic variations:

Already in 1961 a hint of the future periodic Cosmic Microwave Background dipole fluctuations was seen in the Venus radar data. For some reason the content has been classified by the military, so a full analysis of the motions may never be done. Is the daily cycle really sidereal and pointed, like the Cosmic Microwave Background dipole, in the direction of Leo? The question remains: is the speed of light in interplanetary space subject to systematic variations in time? This may be the start of an anomaly that just won't go away.

Shapiro proposed measuring the time delays between radar pulses sent through the sun's gravity field toward Venus and measuring the return time of the echo. Using the MIT 120-foot Haystack antenna,

Shapiro conducted the test in 1966 and 1967 that confirmed radio waves slowed in the gravitational field of the sun. When the Earth, sun, and Venus are most favorably aligned, the expected time delay, due to the passage close to the sun, would be about 200 milliseconds. The test was successful.

Time delay:

In General Relativity, the travel time of any electromagnetic signal can be affected by gravitational time dilation. General Relativity theory predicts a time delay which increases when the photon passes nearer to the sun due to the time dilation while in the sun's gravity potential. Observing radar reflections from Venus just before and after its eclipse by the sun gives 5% error with General Relativity predictions.

Conflict in Findings:

Shapiro has presented the radar data as consistent with Einstein's General Relativity. Yet Shapiro admitted the published radar analysis showed very large improbable variations in the calculated value of the astronomical unit AU (the mean distance between Earth and Sun) that were far larger than the maximum estimated errors. Bryan Wallace claims all calculations by Shapiro were based on the constant c of Special Relativity; the Galilean model $c + v$ wasn't even tested. A complete data evaluation comparing c and $c + v$ was never done, assuming that there is nothing wrong with the Einstein General Relativity model!

When plotted, the AU contained cyclic variations: a daily component, a 30-day lunar component, and a component related to the relative orbital velocities of Earth and Venus. The daily variation was not identified as solar or sidereal. The variations fit the expectations if the speed of light was $c + v$, and the calculations were erroneously based on c . Before the 1960s, the AU had an uncertainty of as much as 170,000 miles because it was only measured by triangulation. With radar, the distance to Venus was precise to 1.5 km., the only important variable being the relative value of c in space.

A data analysis based on a constant c showed the center of Venus at different distances from Earth at the same time. Data analyzed by Shapiro's own research group also presents evidence against the constant c theory of Special Relativity using different ground stations.

Wallace's analysis of the 1961 Venus radar data showed a much better fit to the Newtonian particle $c + v$ model than for the Special Relativity c model, but he was hampered by limited access to the full set of radar data. He wondered how the radar data can be consistent with General Relativity if there are variations far larger than possible when the observing time is changed.

Daily variations will not be evident if readings are taken at the same time each day, yet that is what the released data showed. Shapiro said c was constant based on a constant observing time and a single radar station out of three.

Wallace noted:

The 1961 interplanetary radar contact with Venus presented the first opportunity to perform direct experiments of Einstein's second postulate of a constant c in space. When the radar calculations were based on the postulate, the observed-computed residuals ranged to over 3 milliseconds of the expected error of 10 microseconds from the best [general relativity] fit the Lincoln Lab could generate, a variation range of over 30,000%. An analysis of the data showed a component that was relativistic in a $c + v$ Galilean sense.

...JPL reported that significant unexplained systematic variations existed in all the interplanetary data, and that they are forced to use empirical correction factors that have no theoretical foundation.

The Russians are typically open to reporting and reacting to anomalies in existing theories. From a Soviet journal:

... the discrepancies between the actual position of Venus and the position calculated on the basis of the existing theory of motion of the planets at different inferior conjunctions have different characters....An analysis of the data presented shows that the differences between the measured and calculated delay times have different dependence on the time in the different conjunctions and reach 3500 microseconds, which when converted to the distance from the Earth to Venus comprises 500 km.

Supporting evidence for Wallace comes from Ronald Hatch, who finds that the NASA equations for interplanetary navigation follow his Modified Lorentz Ether Theory (MLET) rather than Special Relativity:

There is a large disjoint between the Special Relativity theorists and the experimentalists. The Special Relativity theorists continue to claim that the speed of light is automatically the velocity c and isotropic with respect to the moving observer or experiment. But the Special Relativity experimentalists do what is necessary to explain and make sense of the measurements. The equations for tracking and navigating the interplanetary probes developed by the Jet Propulsion Laboratory (JPL) for NASA clearly follow the MLET template.

It is therefore imperative that systematic, high precision speed of light experiments be performed in Earth orbit and interplanetary space. No such experiments have been carried out yet.

Brillet-Hall (1979):

A He-Ne laser is servo-stabilized to maintain a fixed reference length using a Fabry-Pérot etalon. L is the length of the Fabry-Pérot etalon – the distance between end mirrors. The etalon and laser can rotate. The light frequency transmitted axially in that rotating frame is compared with a static reference laser. Any length change of the etalon or change in c should produce a matching change of frequency of the rotating laser, using the static stable laser as the standard reference. The test is repeated with the laser placed parallel to the Earth's motion, then at 90° to the motion. The same formulas for parallel and perpendicular transit time in an ether flow are used, but the precision is greatly improved by using monochromatic light and a precise standard. The difference in length predicted by the Lorentz contraction is tested via the servo-stabilization of the etalon length L . Brillet-Hall report a null result after rotation: no change in transit time or L .

Simplified operation:

A laser stabilized with an Fabry-Pérot etalon (a bouncing photon clock) is rotated to various positions and compared to an atomic clock's rate, a laser stabilized to a methane line.

Results:

The null results of the Michelson-Morely experiment lead to the claim of an asymmetric distortion in space and time. The aim is to verify Einstein's hypothesis that there is an asymmetric distortion of space (or matter) when the frame is moving. Brillet-Hall reported the final result as a null ether drift of 0.13 ± 0.22 Hz, which represents a fractional frequency shift of $(1.5 \pm 2.5) \times 10^{-15}$. For the orbital velocity of 30 km/sec, this result is a million times smaller than the ether model prediction. The 370 km/sec. velocity of the solar system with respect to the cosmic background radiation gives an ether model prediction 100 million times larger than the Brillet-Hall limit.

Geocentric analysis:

Now accepted as an accurate confirmation of the Michelson-Morely "null" result, it seems to ignore Miller's criteria for open space around the equipment to optimize ether detection. Their bulky temperature-controlled Fabry-Perot interferometer had little chance of

success. A residual 17 Hz signal (out of $\sim 10^{15}$ Hz) was thought by analysts to be due to the rotation of the Earth. Brilliet and Hall only noted it was fixed in the lab frame and therefore could not be of cosmic origin. But if it was fixed in the lab frame, how could it have a 24 hour solar period?!

The analysis has shown the existence of two ether drift components: (a) An annual component of size 16 m/s and period one year; (b) A larger daily 190 m/s velocity having either a solar or sidereal cycle.

They made measurements every 12 hours, which means the result was phase-dependent. If the samples were taken at the zero crossings of the ether flow sinusoid, the sine wave would appear null.

Torr and Kolen (1981):

Torr and Kolen sent a 5 MHz signal along a 500-meter nitrogen gas-filled coaxial cable orientated east-west to measure the one way light speed variation. The signal was sent between two synchronized Rb atomic clocks and its phase change monitored. They inferred that c could vary in a one way measurement by as much as 1%. Phase differences of 8 nanoseconds or 0.04 wavelengths were found that had an [alleged] spurious dependence on the time of day. Analogous experiments using optical fibers give null results for the same reason, apparently, that transparent solids in a Michelson interferometer also give null results, and so behave differently from coaxial cables.

Geocentrism Response:

Their “null” result means that they could not sense what they were looking for, the 400 km/s motion through space as detected by the Cosmic Background Radiation, just as the “null” Michelson-Morely experiment meant that the 8 km/s reading was not the 30 km/s orbital speed Michelson-Morely were seeking. In hypothesis testing, a “null” result doesn’t mean that nothing was found. There is a definite projection of the absolute motion velocity onto the east-west cable. Torr and Kolen did observe that the round trip-time remained constant within $0.0001\%c$, but variations in the one-way travel time were observed, as shown below by the data points.

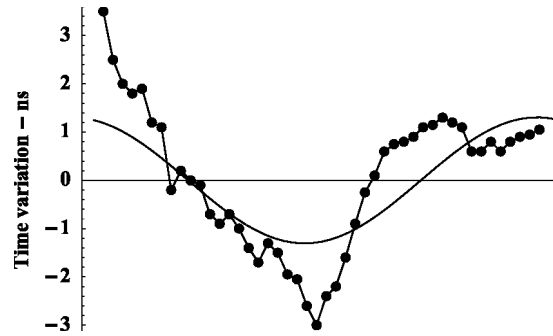

Variations in travel times (ns) of an RF signal sent down a 500 m. of coaxial cable facing East-West. Predicted cosmic velocity (curve) is 433 km/s toward (5.2 hr, -72°).

The theoretical predictions for the Torr-Kolen experiment for a cosmic speed of 433 km/s in the Miller direction (5.2 hr, -67°) and the results of the Torr-Kolen experiment are seen below to be in remarkable agreement.

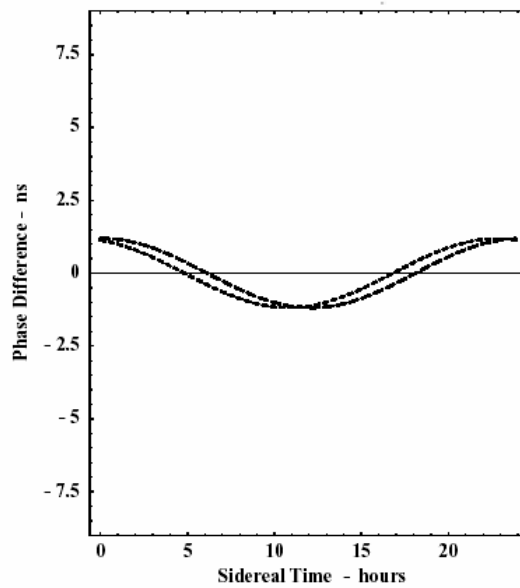
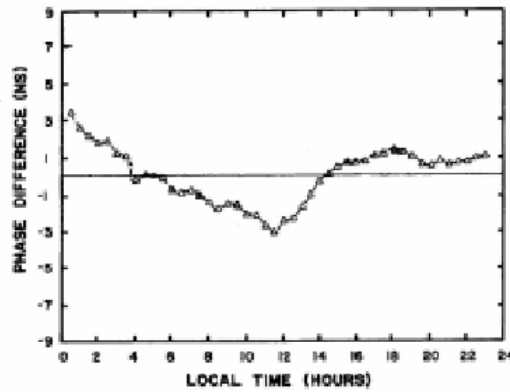

Upper is experiment data for ns variation in transit time via 0.5 km E-W cable ; bottom is predicted curve for 417 km/s in the direction (RA:17:5 hr; Decl: 65°) Results are for a typical day.¹³⁶⁶

Torr and Kolen reported the same fluctuations in both magnitude, (1-3 ns), and time of the maximum variations in travel time, as did DeWitte a decade later, in his sentinel experiment. These one-way results are not predicted by Einstein's theory. This is another confirmation of absolute motion and a mysterious direction in space.

Silvertooth (1986):

Silvertooth used a configuration similar to the Sagnac experiment, adding a sensor capable of measuring the standing wave node spacing that is dependent upon the direction relative to the ether flow. He measured the standing waves formed by light beamed in opposite directions using two lasers. One of the lasers was phase modulated with respect to the other, creating phase conjunctions measured with a special photomultiplier detector. If the apparatus table is rotated in an E-W direction when the constellation Leo is on the horizon, there is a phase difference of 0.25 mm. When rotated 90° (N-S) the detector outputs remain in phase. The detectors also remained in phase in the E-W direction when Leo is 6 or 18 hours from the horizon. With a wavelength of 0.63 μm (He-Ne) the velocity was 378 km/s, in reasonable agreement with the Müller's results in the NASA-Ames U2 radiometer tests.

Analysis:

This is not a confirmation of the Miller experiment because Silvertooth's velocity vector points in a different direction than did Miller's. Silvertooth also calculated a velocity of 378 km/sec, versus Miller's estimate of 200 km/sec.

NASA discovered that the motion of our solar system causes a slight Doppler shift in the spectrum of the CMB. This anisotropy indicates that the heliocentric frame moves toward the constellation Leo with a velocity of 390 km/sec, in excellent agreement with Silvertooth's findings. But Silvertooth published his results before the COBE satellite discovery.

Just as Sagnac's experiments showed c is not constant in rotating frames of reference, Silvertooth's experiment shows that c also fails to apply to light moving in a straight line. Silvertooth claimed that two way light speed tests, such as Michelson-Morely, would always cause cancellation of the velocity difference in c each way. But Cahill has

¹³⁶⁶ http://www.mountainman.com.au/process_physics/HPS14.pdf Fig.16

shown that the refractive correction for a gas medium causes a true difference in the two opposite paths through the ether.

There are no references to Silvertooth's papers or his two experiments in the mainstream scientific literature. Unless this challenge to Relativity theory is met, the logical conclusion would be that motion can be detected by pure electromagnetic means and that Einstein's theory of Special Relativity is false.

Claims and Responses:

Claim #1: The Earth moves in space with an absolute velocity. The value of this velocity (378 ± 19 km/sec) matches the independent astronomical determination of the Earth's motion relative to the cosmic background radiation (365 ± 18 km/sec).

Response: The other unexpressed possibility of interpretation is that the ether is moving against the Earth, which is at rest, not the Earth moving through the ether. At all times he found a preferred direction pointing to the constellation Leo, traveling at a velocity of 378 km/sec.

Claim #2: Silvertooth's theory, method and/or data are erroneous

Response: Critics have to explain why other ether experiments sensibly measured the same velocity – speed and direction.

DeWitte 1991:

Two sets of atomic clocks in two buildings located close to a North-South line were separated by 1.5 km. Two 5MHz radio frequency signals were sent in both directions through two buried coaxial cables linking the two locations. Digital phase comparators measured changes in propagation times of the radio frequency signals in both directions for 178 days; long term drift was very linear and reproducible. The phase changes displayed a clear sinusoidal waveform with a consistent sidereal day period for the duration of the experiment.

Theory:

Let the projection of the absolute velocity vector \mathbf{v} onto the direction of the coaxial cable be v_p . Then the phase comparators reveal the difference between the propagation times in the N-S and the reverse S-N direction. The analysis for the time difference without considering a Fresnel drag effect:

$$\Delta t = L/(c/n-v_p) - L/(c/n+v_p)$$

$$= 2Ln^2v_p/c^2 + O(v_p^2/c^2) \sim 2t_0nv_p/c$$

$L = 1.5$ km is the length of the coaxial cable and $n = 1.5$ is the refractive index of the cable dielectric, so the signal speed is about $c/n = 200,000$ km/s. $t_0 = nL/c = 7.5 \times 10^{-6}$ seconds is the one-way radio frequency travel time when the horizontal ether flow $v_p = 0$. Then, for example, a value of $v_p = 400$ km/s would give $\Delta t = 30$ ns. Being first-order in v/c , relativistic effects of second-order in v/c can be ignored. This advances experimental technique beyond the two-way light speed of Michelson-Morely type experiments.

DeWitte's new type of absolute motion experiment measured 400 km/s that, significantly, agrees with the re-analysis of prior gas interferometer tests based on the refractive index effect. Measured values of velocity V_m were corrected and properly scaled using $V = V_m(n^2 - 1)^{-1/2}$

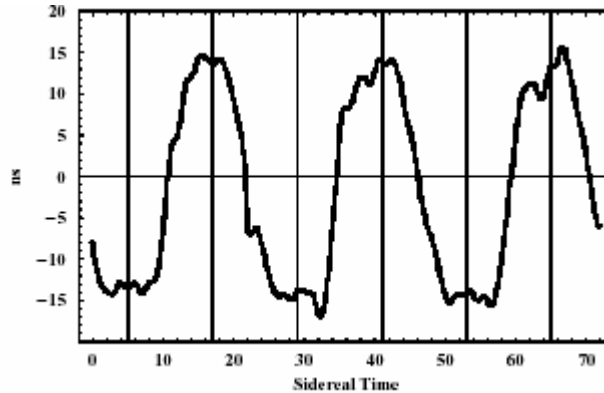

Variations in twice the one-way travel time in ns, for a radio frequency signal to travel 1.5 km through a North-South coax cable. The sidereal time for maximum effect - ~17 hr (or ~5 hr) - agrees with the direction found by Miller and by Jaseja. Plot shows variation of some 28 ns over 3 sidereal days.

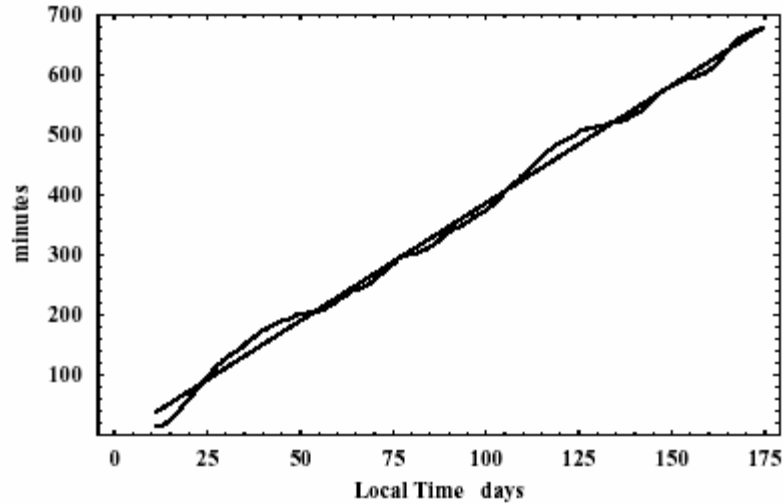

Drift of cross over time between max and min transit time variation plotted against the solar time for half a year. The slope of the least-squares fit is 3.92 min per day, while the difference between solar and sidereal day is 3.93 min/day.

Sidereal day:

A sidereal day measures the time for a star overhead to return to its exact position, just as a solar day is the time for the Sun to return to its position. Anything related to solar motion will generate data that synchronizes with a 24 hour day exactly, not one that is 236 seconds shorter. Because of the 4 minute difference between the two types of day, there will be 1 extra sidereal day after a year; 1 year = 365 solar days = 366 sidereal days.

Analysis:

The detected signal leads the sun by the same amount the stars do! So the time variations are correlated with sidereal time and not local solar time. The effect is certainly cosmological and not associated with any daily thermal effects, which in any case would be very small for a buried cable. Miller had also compared his data against sidereal time and found his data also tracked sidereal time and not solar time.

The sidereal dependence of the Dewitte readings is incomprehensible in the world of Relativity. A sidereal period can only be attributed to the motion of the Earth relative to the cosmos, requiring an absolute reference frame, which Einstein said does not exist. Neither Special Relativity nor General Relativity could or would ever predict a sidereal day effect.

The reaction of the physics mainstream journals has been silence, when such a paradigm-crunching discovery should objectively be making headlines on the covers. A sidereal period implies relative

motion of the Earth and the universe. DeWitte detected an absolute reference frame that Einstein said did not exist.

A sidereal variation in the velocity of light means the very foundations of physics as currently believed have a fundamental error that must be corrected. A rotating cosmos would also challenge another science icon, the Big Bang. Objective science journals could have published the results, disclaiming his interpretation, unless they also could disprove his data. Since 1991 no one has analyzed DeWitte's results in the technical press or even attempted to replicate his data.

Some interpret the DeWitte data by concluding that the Earth is rotating once every sidereal day. They say he detected a second reference frame to which the Earth is subject, other than the geocentric frame itself. Whatever affects, phase shifts in copper wires with a sidereal pattern must be related to the motion of Earth in open space. But Mach's principle still holds – the Earth can just as well be at rest while the stars rotate. There is no need for a second frame. The geocentric model is an equally valid analysis of the DeWitte results.

CMB dipole 1996:

The hot Big-Bang model has become the standard cosmology of modern physics. The cosmic microwave background is a 2.725 kelvin thermal spectrum of black body radiation that fills the universe, a remnant of the birth. It is isotropic to roughly one part in 100,000; the standard deviation is only 18 μ K.

The Cosmic Microwave Background radiation is a snapshot of the universe when these photons of formation last scattered. At that time the opaque universal plasma finally cooled down enough to become a transparent gas of neutral atoms. As the Universe expands it cools, and so we see the background radiation as microwaves, coming from all directions. The Cosmic Microwave Background served as a cosmic Rosetta stone, for those days 13 billion years ago.

The mapping of the Cosmic Microwave Background was expected to reveal the small random temperature variations caused by star and galaxy formation 300,000 years after the expansion began. Analysis of the COBE data by Smoot et al., exposed a large (relative to the 2.725° K monopole) anisotropic dipole amplitude of 3.358 milliK, assumed to be due to our velocity with respect to the Cosmic Microwave Background. Good agreement with the DMR and FIRAS dipole results was evidence that the COBE dipole detection was not due to systematic uncertainties in the equipment.

COBE temperature graphics:

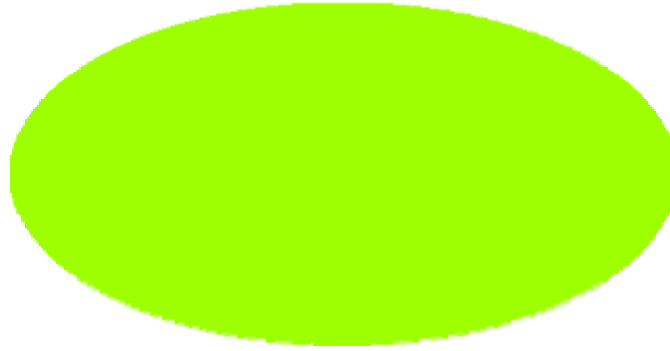

The CMB monopole¹³⁶⁷

The Cosmic Microwave Background's original temperature map of the sky showed a remarkable universal smoothness, a constant temperature of $T_0 = 2.725^\circ\text{K}$, symbolized by green above.

In 1992, satellite telescopes (e.g., COBE), 500 times more sensitive than prior telescopes, revealed a faint pattern in the Cosmic Microwave Background sky spectrum when viewed from galactic coordinates, as shown below.

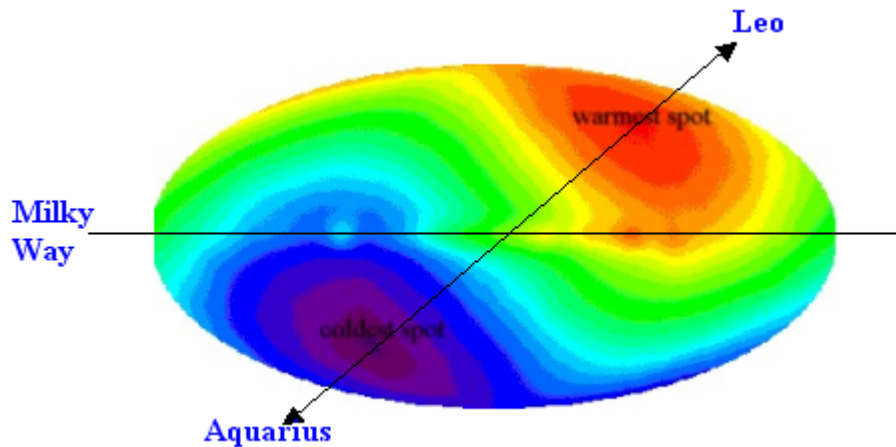

The CMB dipole¹³⁶⁸

A dipole anisotropy was now seen, with the hot pole in red in the direction of Regulus, and the cold pole in purple at lower left in the opposite direction. The red part of the sky is hotter by $(v/c) \times T_0$, while the blue part of the sky is colder by the same amount. The inferred velocity is $v = 370$ km/sec, the velocity of the solar system relative to the observable universe. The direction is (RA: 11hr. 12mn. Decl: -7.06°).

¹³⁶⁷ http://map.gsfc.nasa.gov/ContentMedia/dmr_0_s.gif

¹³⁶⁸ http://map.gsfc.nasa.gov/ContentMedia/dmr_1_s.gif

Radiation in the Earth's direction of motion appears blueshifted (higher frequency) and hotter, while radiation on the opposite side of the sky is red shifted and colder. The Local Group moves at about 600 kilometers per second relative to this primordial radiation, a high speed that was initially unexpected - its magnitude and direction are still unexplained.

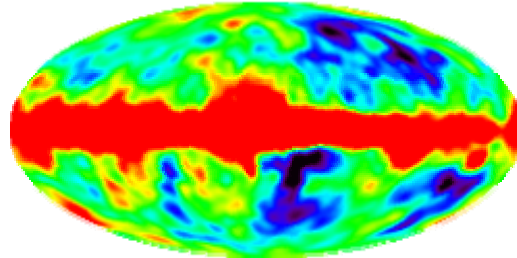

CMB sky minus the dipole¹³⁶⁹

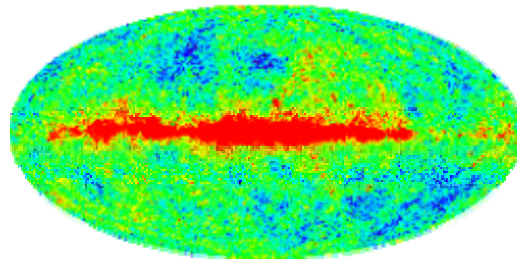

The full CMB sky at high resolution¹³⁷⁰

The full map of the sky is shown above, including all mK fluctuations. The Milky Way is located at the equator in this galactic reference system. The color details are tiny temperature differences of an incredibly even microwave radiation filling the universe, now at a frigid 2.73 degrees above absolute zero temperature.

A high resolution view of the temperature details is shown below, with slight temperature fluctuations which vary by only millionths of a degree.¹³⁷¹

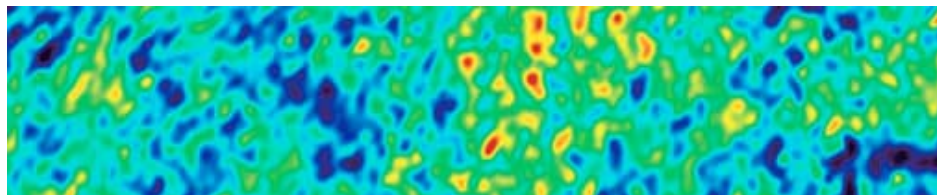

¹³⁶⁹ http://map.gsfc.nasa.gov/ContentMedia/dmr_2_s.gif

¹³⁷⁰ http://map.gsfc.nasa.gov/ContentMedia/map_model_2_s.gif

¹³⁷¹ NASA - WMAP

Geocentrism outline:

The Cosmic Microwave Background is considered the most conclusive piece of evidence for the Big Bang by current cosmology. It is the isotropic radiation bath that permeates the entirety of the universe. Accidentally discovered in 1964, it was soon determined that the radiation was diffuse, emanated uniformly from all directions in the sky, and had a temperature of approximately 2.73 Kelvin. It is now explained as a relic of the evolution of the early universe.

In the Big Bang theory, as the universe expanded and cooled, there came a point when the photon radiation decoupled from the matter. The radiation cooled and is now at 2.73 Kelvin; it matches the blackbody curve for that temperature very closely. Although it is considered to be unequivocal proof for the so-called Standard Big Bang model, in actuality:

- This is another example of the ‘effect implies cause’ logical fallacy: if a cause C produces an effect E , then E does not necessarily produce C . In other words, finding one cause for an effect does not exclude other possible causes for the present 2.73° K temperature.
- The parameters of the Big Bang model can be adjusted to fit any temperature. The predicted temperature was as high as 50° K before the Cosmic Microwave Background discovery. The claim of uniqueness would be impressive if stated before 1964, and after the parameters had been chosen.

Abuse of the Doppler effect:

The Doppler effect holds for either source or observer (or both) in motion, a phenomenon truly based on relative motion. Relativity supporters abuse this simple fact when interpreting the Cosmic Microwave Background dipole as motion through space in Leo’s direction by the:

- Earth
- Solar System,
- Galaxy,
- Local Group of galaxies or
- Some other arbitrary celestial grouping.

For if the Cosmic Microwave Background dipole arises from the Doppler effect, as claimed, it can just as well be taken that the cluster around Regulus is the source of the motion, approaching Earth. The

choice of Earth moving toward Regulus is one of many options of relative motion allowed by the Doppler theory. It is ironic that a Geocentrist has to point out to Relativists that they are abusing a principle based on relative motion, by ignoring the valid geostatic option.

Claims and Responses:

Claim #1: Although the universe as a whole has no center and no edges, our observable universe's edge is the cosmic microwave background. We are moving (slightly) with respect to that edge.

Response:

- 1) With no edges the universe would be infinite and unchanging, as only finite things can change. If an infinite universe changed, it could not have been infinite originally. We are surrounded by change/motion, so the universe cannot be infinite.
- 2) If the universe has no edges how can the Cosmic Microwave Background be the edge - an edge that doesn't exist?
- 3) General Relativity models claim that the Big Bang universe is expanding into nothingness, an expansion not into space but creating space as it expands. This space curves back on itself so there is no center or edge (NB: I hope that's clear to everyone). There is no experimental proof of this model, created from nothing by very fertile imaginations.
- 4) Big Bang interpretation notwithstanding, our speed relative to the Cosmic Microwave Background is nowhere near the speed of light, and so we must be very close to the expansion center. Even the Big Bang shows the universe to be geocentric!

Claim #2: The Cosmic Microwave Background could only have arisen from the very hot, dense conditions that existed in the early Universe.

Response: There are many logical sources for a universal background of electromagnetic radiation described in cosmology literature, some from the period before the Big Bang model was promoted, some from explanations of Olber's paradox. The principal counter argument is based on the scattering of the light produced by all the universe's stars. Over time the scattered waves would be reduced to 2.7° K, the temperature of the universal container, which Geocentrists apply to the water above the firmament (Genesis 1:6-9).

Claim #3: The 3mK dipolar temperature variation across the sky arises from the motion of the solar system with respect to the rest frame defined by the Cosmic Microwave Background.

Response: (1) If the Cosmic Microwave Background fills the universe then its rest frame must be the absolute frame forbidden by Relativity; (2) Solar system motion? See abuse of Doppler effect.

Claim #3: COBE even detected the annual variation due to Earth's motion around the sun - the ultimate proof of Copernicus' hypothesis.

Response: Other ether detection experiments – from Milller to DeWitte – have two distinct variations:

- A primary one with period of a sidereal day
- A secondary one with period of one year.

It is the secondary dipole variation that is referred to here, lending Cosmic Microwave Background support to the results of the other investigations. For Earth's motion around the sun, see abuse of Doppler effect.

Claim #4: The COBE 30 μK pattern displayed the creation of stars and galaxies in the early stages of the universe. It provided the first evidence for the density inhomogeneities from which all structure in the universe originated, confirming the Big Bang model.

Response: If the above were true, there would be:

- no clear dipole pattern, as seen in reality.
- a correlation between the observed density irregularities and the present structure of the universe. No such correlation has been published in the physics mainstream press.

Claim #5: The Cosmic Microwave Background dipole shows that we are traveling very fast through the universe. There is the motion of our Local Group of galaxies relative to the Cosmic Microwave Background photons, the motion of our Galaxy relative to the Local Group as a whole, the motion of the sun round the galaxy, and the annual motion of the Earth round the sun. If you were to believe that we are genuinely at rest in a special place, then you would have to decide where that rest place is.

Response: That makes velocity a matter of personal choice, and thus meaningless. In effect, the term “velocity” has no meaning in cosmology if it can be chosen to be anything. Also, see abuse of Doppler effect.

Claim #6: A plausible explanation for this observed large-scale anisotropy in the pattern of Cosmic Microwave Background radiation is that the radiation is isotropic on a large scale in the medium through

which it is propagated and the solar system is moving through the medium with a velocity of .0012 times the speed of light through the medium. This velocity in the general direction of the star Regulus would cause Doppler shifts in the observed Cosmic Microwave Background radiation that would result in the observed dipole presence.

Response: But what of the contradictory interpretation of universal redshift recession? Why isn't the Big Bang recession of galaxies at much greater speed than the dipole speed detected in the Cosmic Microwave Background? What makes the cosmic expansion speeds invisible? Perhaps an objective view is that:

- The galaxies are not receding but are basically at rest in a radial direction
- The Earth is at rest, and the Regulus group is approaching us.

Claim #7: 1) The dipole effect is the result of the movement of our Earth, solar system, and galaxy through the universe; similar to the change in pitch of a sound as you ride by the source in a car or train. Specifically, the Cosmic Microwave Background temperature is 6.706 mK brighter in one direction of the sky than it is in the opposite direction as measured by the COBE mission. (2) Dipole effect caused by the Doppler effect of the Earth's movement in the Cosmic Microwave Background reflects the directional movement of the Milky Way.

Response: See abuse of Doppler effect.

Claim #8: There is a slight imbalance in the recession speeds of distant galaxies. In the direction of the constellation Leo they are not receding as fast as in the other direction.

Response: We are told the recession speed is dependent on distance, so there is a wide distribution of expansion speeds for remote galaxies. How does the Cosmic Microwave Background pick out only the Leo dipole speed, which is much less than the deep space recession speeds?

Claim #9: Special Relativity theory is not complete; it was replaced by General Relativity theory circa 1915.

Response: We can conclude, then, that:

- Special Relativity theory cannot be used for cosmology.
- General Relativity theory did not extend Special Relativity to accelerated frames and gravitational fields, as most others claim.

Claim #10: In General Relativity, when you get a solution to the Einstein equations that defines a spacetime, then typically that spacetime has a preferred frame and you can determine an absolute velocity. The metric which normal working cosmologists use, the Friedman-Robertson-Walker metric, has a built in absolute rest and a notion of absolute velocity. In an expanding universe there is a preferred frame, or class of preferred frames (there is no preferred origin).

Response: A revealing re-write of Relativity, which now does not allow a free choice of reference systems, but uses models with absolute speeds. Without a preferred origin, we know how fast we are going, but not where we are?! Apparently all the content and meaning can be changed in Relativity, but never the name itself. The greatest obstacle to discovery is not ignorance, but the illusion of false knowledge.

Claim #11: The crucial assumption of Relativity is that there are no reference frames where the laws of physics are different. Yet there is a reference frame where the Cosmic Microwave Background is at rest. You could call this the rest frame of the universe, but observers in that reference frame have no ‘privileged’ view of the universe and there is nothing any more ‘absolute’ about the velocity of an object with respect to that frame than with respect to any other reference frame. No experiment done in the Cosmic Microwave Background rest frame would yield a different result than the same experiment done in any other reference frame. All the laws of physics operate exactly the same as they do in the Earth rest frame, or any other reference frame.

Response: Yet another view of what Relativity and rest frame mean. Although almost all believers in Relativity say they subscribe to the Einstein brands of Special Relativity and General Relativity, each seems to have an individual interpretation of the meaning and application of Relativity to experimental results. These interpretations are usually divergent. The above argument claims that all frames are equivalent (and does not even restrict the choices to inertial frames), but ignores the testimony of the Cosmic Microwave Background dipole, that is, that there is a preferred orientation in space, as seen from Earth.

Claim #12: If the Earth were the focal center of the universe the Cosmic Microwave Background would show no dipole effect, as it too would revolve around the Earth.

Response: The Cosmic Microwave Background dipole is usually interpreted as caused by the motion of the Earth at 370 km/s through the Cosmic Microwave Background toward Regulus. But the data itself indicates that the Regulus direction is an energy source, the hottest spot in the Cosmic Microwave Background spectrum of the universe, a

possible source for the ether flow that causes the effects we now term gravity and the periodic motions of the heavens. The source acts as a beacon as the sky rotates each (sidereal) day.

Claim #13: The variation in the universe's temperature shows how the matter and energy of the very early universe (300,000 years of age) were distributed. In order for the mass of the universe to be clumped together nowadays in galaxies and galaxy clusters, theory requires that the early universe be non-uniform. The COBE discovery revolutionized cosmology by giving us rich information about the initial conditions of the universe.

Response: What the COBE Cosmic Microwave Background dipole revealed to us was not anything about the universe's start, but rather it:

- Disproved the cosmological principle of large-scale homogeneity.
- Challenged the foundations of the Big Bang theory.
- Established a universal energy source and direction in space.
- Was totally unexpected and still unexplained by theorists.
- Established that the universe has an absolute reference system, debunking Relativity theories and crying out for new paradigms for explanation (or the revival of pre-Copernican beliefs).

Summary:

In Special Relativity, there is no special linear velocity determined by the laws of physics, per se, but the velocity of the cosmic microwave background radiation is considered special, and a sophism intended to ignore the stark collision with Special Relativity theory. A firm statement is made (e.g., no absolute reference frame) followed by an immediate exception (e.g., the Cosmic Microwave Background) which is hedged (e.g., it could be a preferred frame [but which Relativity theory forbids]). This logical tangle sets the scene for accepting a contradiction within the Relativity paradigm – the Cosmic Microwave Background as a universal absolute rest frame.

Nodland Ralston (1997):

In 1997, Nodland and Ralston measured astronomical polarization of light from galaxies from various distances and directions. Analysis of the data indicated that the universe seemed to have an optical axis: it rotated the polarization direction of linearly polarized light! This cosmic polarization had an optical axis parallel to the direction Aquila-Earth-Sextans. Could the universe be rotating?

In the standard cosmic model, the universe is expanding symmetrically from its Big Bang origin and space has no preferred direction. Light moves isotropically, coming from any direction. However, polarization measurements from distant radio galaxies that emit strongly polarized waves similar to synchrotron radiation showed a rotation of the polarization plane that was proportional to the propagation distance as projected along a fixed direction in space. The magnitude of the polarization was empirically found to be:

$$Kr \cos\theta$$

where K is a constant, r the distance from Earth to source, and θ the angle from line of sight to the equator. The rate of rotation of the polarization plane depends on the angle between the direction of travel of the polarized wave and a fixed direction in space, pointing approximately toward the constellation Sextens from Earth. The closer to parallel of the direction of straight-line travel of the wave with this fixed direction, the greater the rotation of the polarization plane of the wave. The amount of polarization rotation is also proportional to the distance traveled.

The rotation claimed was truly small: one period of polarization rotation completed in about ten billion (10^{10}) years. The signal was detected in the microwaves emitted by distant radio galaxies and separated from common Faraday rotation produced by magnetic fields in the intervening space. The results represent an analysis of electromagnetic radiation data that has been compiled and published by several independent research groups since the 1980s. Polarization measurements of electromagnetic synchrotron radiation emitted by distant radio galaxies were studied. Extensive computer aided calculations indicates that this radiation exhibits an unconventional rotation of its polarization plane. The effect is small, and is masked by other polarization rotation effects. The polarization rotation depends systematically on the angle between the radiation's direction of travel and a fixed direction in space, indicating electromagnetic anisotropy.

Birefringence:

Does the universe behave like a special type of optical crystal in which light in one direction acts differently from light in a different direction? Radio waves from distant galaxies must pass through random magnetic fields and cosmic plasma composed of ions and electrons. The Faraday effect predicts the polarization of the radio waves (the orientation of their electric fields) will rotate slightly on their way through space. The effect is proportional to the magnetic field strengths and ion densities, as well as the square of the wavelength.

Claims and Responses:

Claim #1: The infinite anisotropy axis running through Aquila, Earth and Sextans only represents a *direction*, a *vector* in space. Any other axis – possibly vastly remote from Earth, Sextans and Aquila – parallel to the anisotropy axis shown here, will suffice in defining the anisotropy vector. No particular *location* in space, like the location of Earth for example, is relevant - only *directions* are relevant.

Response: The observations from Earth indicate that the axis passes through, and is centered on, the Earth. Maintaining that the line is a vector representing an infinite set of parallel lines in the Sextans-Earth-Aquila direction is a mathematical statement without experimental support. Observation of the polarization far from Earth would be needed to confirm the claim above.

Claim #2: A local effect of the Milky Way galaxy might account for our correlation.

Response: The correlation is seen for large redshift/distances ($z > 0.3$) but not at small distances where $z < 0.3$. This effectively rules out a local effect.

Claim #3: Strong galactic magnetic fields might generate non-random polarization directions, or upset the Faraday-based compensations. There would also have to be a distance dependence for this preferred orientation.

Response: But the correlation is observed over the entire sky; any explanation like this requires a highly unlikely conjunction and cooperation between remote objects at large angles of separation. A study of polarization rotation data for 160 galaxies points to a mysterious angular dependency across the sky, as if the universe had an axis. This anomaly challenges some sacred icons in physics, for example:

- there is no preferred motion in space – in direction or speed.
- space itself is isotropic (the same in all directions) or
- homogeneous (the same in all places).

Summary:

Nodland and Ralston do not suggest rotation as a possible explanation, saying it may be the vacuum of space twisting the electric fields of the radio waves to polarize them in transit. Without using the word “ether” itself, this statement is essentially the contention of the

Geocentric theory – that the firmament causes all the heavenly motions we see, even the smallest details. It was found that the universal torsion fields [here read ether flow] produce rotation of particles as they travel, are not evenly distributed, but rather form a cosmic axis through space. The closer a particle is to this cosmic axis, the more rotation is produced. For one who is unencumbered by modern cosmic speculative theories like the Big Bang and the Cosmic Uniformity Principle, the simplest explanation would be a real axial rotation of everything in a finite universe. Of course a cosmic axis is anathema to Big Bang theorists because it implies a center and an edge to the universe. In contrast to the drawn-out two-year peer review process given to the Nodland-Ralston paper, the criticisms in reply were almost immediate and seemed a bit desperate in their dismissal of the careful investigation. Is it coincidence that the constellation Sextans stands for the *sextant*, the ancient instrument by which mariners would navigate? Or that Aquila is a messenger from Heaven – the mythological Eagle leading souls to immortality.

Several authors (e.g., Birch, Obukhov-Korotky-Hehl and Kühne) have dared to use a cosmic rotation model to explain the results, but try to maintain the standard cosmic view using General Relativity. Rotation of the polarization of an electromagnetic wave would be an effect of the cosmic rotation and spacetime curvature, which also accounts for other image characteristics like size, shape and orientation.

Pain and Ralston later used a larger data set and found that isotropy was definitively eliminated. The direction was slightly adjusted from the original report to be at: [R.A. = (0h, 9m) \pm (1h, 0m), Decl. = $-1^\circ \pm 15^\circ$]. This puts the polarization axis on the vernal equinox line, which is the line in space connecting the sun with the Earth when day and night are of equal length. Axis parameters concordant with the axis parameters in Nodland and Ralston have been found to coincide with the Cosmic Microwave Background dipole direction by Kuhne and by Bracewell-Eschelmann.

There seems that the statistical analysis is pointing out two directions of polarization:

1. The Cosmic Microwave Background dipole direction toward the Leo-Virgo clusters, independently determined by COBE.
2. A new direction in the ecliptic plane along the equinox, which will be confirmed by analysis of higher Cosmic Microwave Background multipoles.

The data does not lie. Objective physicists are now being dragged, albeit reluctantly, in the direction of truth. We interpret the galactic polarization data as indicative of sources that are geocentric: symmetric around AND centered on the Earth!

Tegmark CMB quadrupole, octopole (2005):

What are multipoles? Multipole vectors are a mathematical representation of the Cosmic Microwave Background sky in expanded spherical harmonic coordinates yielding evidence for statistical correlation of multipoles with spatial anisotropy (preferred cosmic directions). Note that the origin of the spherical expansion is the Earth. This is the tool chosen to analyze the Cosmic Microwave Background spectrum. Graphic representations shown below for lowest multipoles:

l	Name
0	Monopole
1	Dipole
2	Quadrupole
3	Octopole
4	Hexadecapole

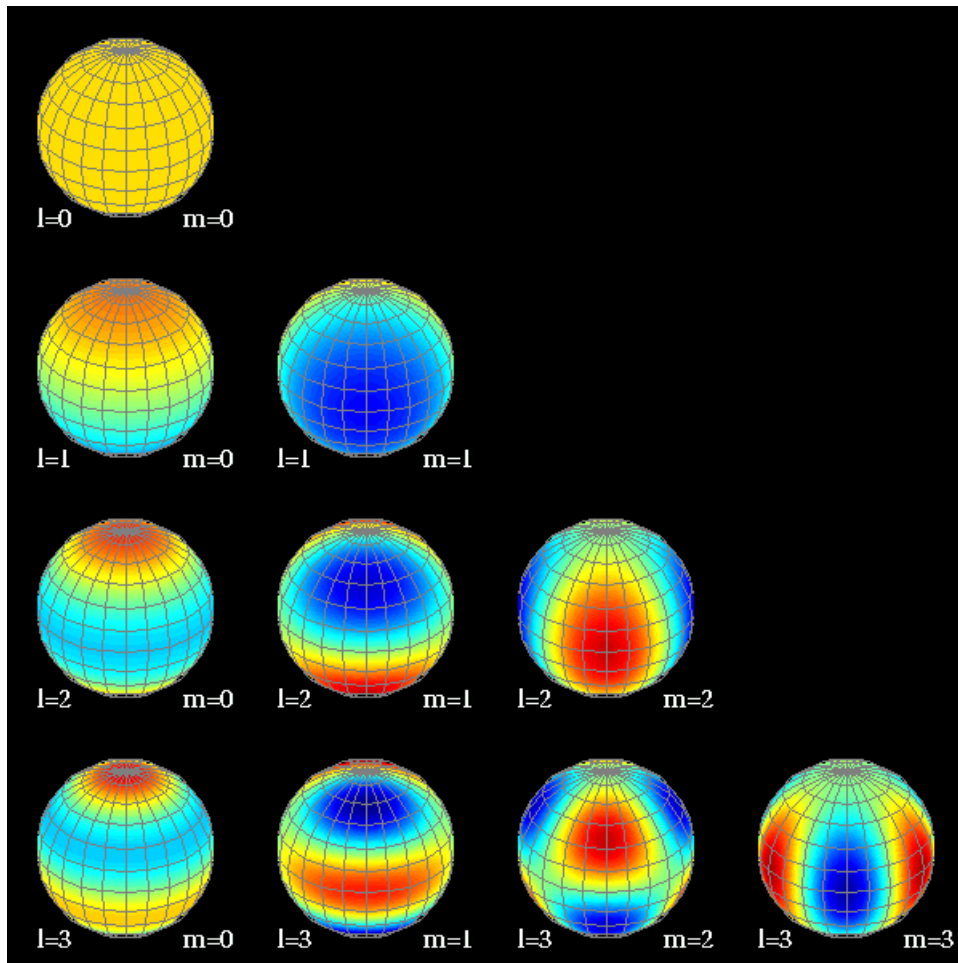

Clem Pryke (pryke@aupc1.uchicago.edu)
Cosmic Microwave Background multipoles for $l = 0$ to 3 and $m \leq l$

Overview:

The multipole vector framework was applied to full-sky maps derived from the first year Wilkinson Microwave Anisotropy Probe (WMAP) data. The Wilkinson Microwave Anisotropy Probe appears to show something amiss with the standard model of cosmology, as it takes the sky temperature from 1.5 million kilometers in space. “Inflation plus cold dark matter” is the working hypothesis for how structure formed in the universe. The precise shape of the angular power spectrum depends not only on the underlying inflation model, but also on cosmological parameters such as the Hubble constant, the mass density and the composition of the dark matter. The 2500 or so independent multipoles that can be measured have enormous potential to determine cosmological parameters and to test theories of the early universe.

Cosmologists think the tiny variations were imprinted when matter began to clump together under gravity as the Big Bang cooled. Hotter patches were once denser regions, cooler patches were once less dense. The density variations began as quantum vacuum fluctuations during the universe’s first moments and which were blown up by inflation, a period of accelerated Big Bang expansion. These random quantum variations should be found in the broad cosmic features of the Cosmic Microwave Background as random and patternless, with no specific identification of local objects or structures.

After correcting for the dipole’s Doppler effect, it was found that the temperature of the galactic plane (coming from our galaxy) is slightly warmer than the rest of the universe. This represents the higher pole contribution to the Cosmic Microwave Background temperature map.

In 2005, Magueijo and Land found an alignment in the cosmic microwave background. The large-angle (low-) correlations of the Cosmic Microwave Background exhibit several statistically significant anomalies compared to the standard inflationary cosmology. The quadrupole plane and three of the octopole planes are very closely aligned. Three of these planes are orthogonal to the ecliptic, and the normals to these planes are aligned with the direction of the Cosmic Microwave Background dipole and with the two equinoxes. The remaining octopole plane is orthogonal to the supergalactic plane. All these alignments have confidence levels $> 99\%$. In fact a comparison with 100,000 random skies populated by Monte Carlo methods shows each correlation is unlikely with 99% confidence. The hot/cold spots in each pattern seemed to line up along the same direction, contrary to the random distribution assumption. Magueijo called this alignment “the axis of evil.”

Analysis:

1. The near vanishing of the two-point angular correlation function at angular separations greater than about 60 degrees, related to the low amplitude of the quadrupole contribution ($l = 2$ spherical harmonic) in a spherical harmonic expansion of the Cosmic Microwave Background sky. The real significance of this low value compared to the predictions of the Big Bang is now contested by mainstream scientists.
2. The ecliptic line moves between hot spots and cold spots over a third of the sky, avoiding the octupole extrema over the rest.
3. Deviation from the predicted bell-curve distribution. The quadrupole-octopole correlation is statistically excluded from being possible in a Gaussian random isotropic sky.
4. The quadrupole spectrum is almost the same as the dipole spectrum.
5. The quadrupole and octopole are aligned.
6. The octopole is unusually planar - the hot and cold spots of the octopolar anisotropies lie nearly in a plane.
7. The quadrupole-octopole correlation is excluded from being a chance occurrence in a Gaussian random statistically isotropic sky with high confidence.
8. Three of the four octopole normals lie near the ecliptic plane.
9. Three of the four planes defined by the quadrupole and octopole are nearly orthogonal to the ecliptic.
10. A chance alignment of the normals with the ecliptic plane is excluded at $> 99\%$ copn.
11. The three normals near the ecliptic also lie very near the axis of the dipole.
12. The dipole axis lies close to the equinoxes.
13. Three of the normals align with the equinoxes.
14. Four of the normals are orthogonal to the ecliptic poles.
15. Three of the four planes defined by the quadrupole and octopole are nearly orthogonal to the ecliptic.
16. A north-south ecliptic asymmetry – the three extrema in the north are visibly weaker than those in the south.
17. Planarity of the quadrupole-plus-octopole.
18. The planes defined by the octopole are nearly aligned with the plane of the Doppler-subtracted quadrupole.
19. Three of these planes are orthogonal to the ecliptic plane, with normals aligned with the dipole (or the equinoxes).
20. The fourth octupole plane is perpendicular to the supergalactic plane.
21. The ecliptic threads between a hot and a cold spot of the combined Doppler-subtracted-quadrupole and octopole map.
22. The ecliptic separates the three strong extrema from the three weak extrema of the map.

23. A deficit in large-scale multipole power exists between the north and south ecliptic hemispheres.
24. The $l = 4$ to 8 multipoles are very unlikely to be correlated ($< 1\%$) with $l = 2$ and 3.
25. Most low multipoles of the near Galaxy are far from the Cosmic Microwave Background multipoles, removing the Milky Way structure as a reasonable cause of the observed Cosmic Microwave Background correlations.
26. The presence of preferred directions in the multipoles seems to extend beyond the octopole to higher multipoles, with an associated mirror symmetry

All 26 of these anomalies contradict the standard picture of the universe and have no explanation.

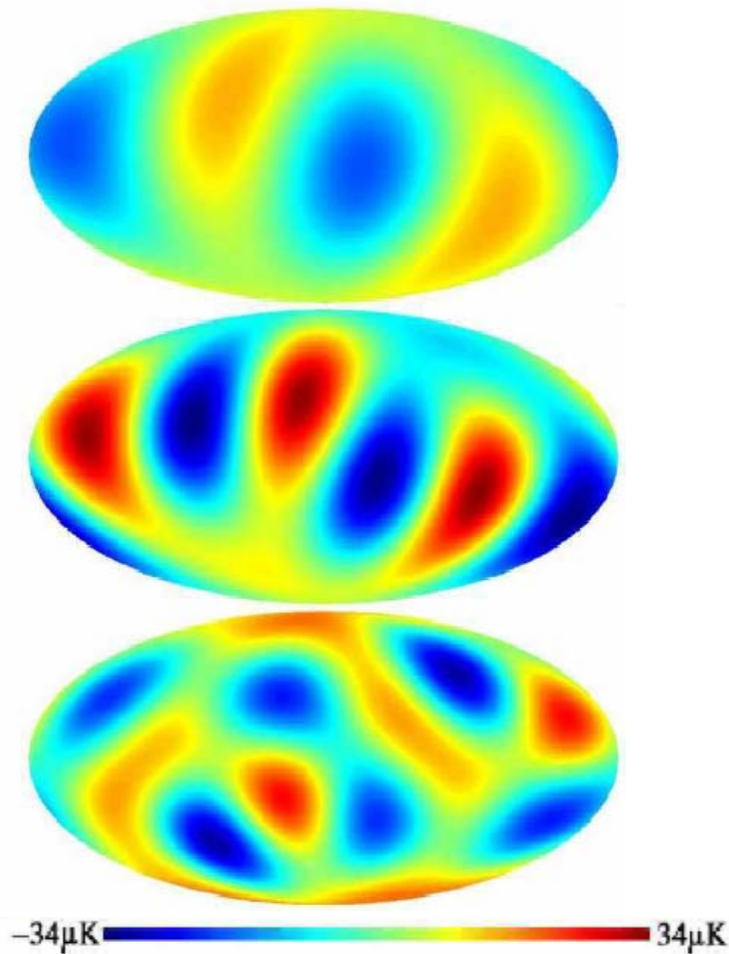

Dipole-filtered CMB Map¹³⁷²

The quadrupole (top), octopole (middle) and hexadecapole (bottom) components of the dipole-filtered CMB map on a common temperature scale. The quadrupole has low power; both it and the octopole have a common axis in space - the Galaxy plane.

Significant features of the diagram above:

1. Both the quadrupole and the octopole have their power suppressed along a particular axis between the two, roughly towards (-110°, 60°) in Virgo.
2. How significant is this quadrupole-octopole alignment? The probability is only about 1.6% of an accidental chance alignment.

¹³⁷² <http://lambda.gsfc.nasa.gov/>

3. The quadrupole magnitude is low with a suspicious alignment. A generic quadrupole has three orthogonal pairs of extrema (two maxima, two minima and two saddle points). The actual Cosmic Microwave Background quadrupole has its strongest pair of lobes near the Galactic plane.
4. Filtering the galaxy contribution primarily affects the quadrupole, removing a large fraction of its power. Other poles are affected slightly.
5. The saddle point is close to zero, implying a preferred axis in space where the quadrupole has no power.
6. The observed quadrupole is the sum of the cosmic quadrupole and the dynamic quadrupole due to our motion relative to the Cosmic Microwave Background rest frame. The latter should be subtracted when studying the cosmic contribution.
7. The overall octopole power is large, having a preferred axis along which power is suppressed, the same axis as the quadrupole.
8. In contrast, the hexadecapole acts like an isotropic random field, with no intrinsic direction detected.

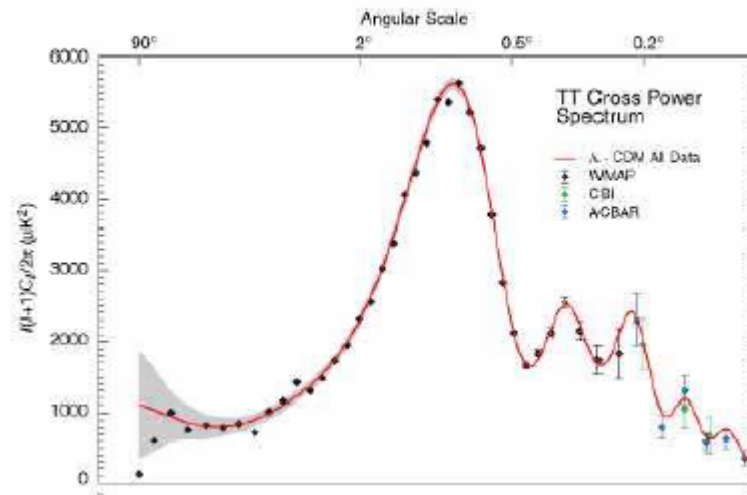

**WMAP angular power spectrum
of CMB temperature fluctuations.**¹³⁷³

The separation angle plotted at top is conjugate to the multipole number l : $\theta \sim 180^\circ/l$. This multipole plot does not agree with theoretical predictions for an infinite Euclidean space (red curve), but deviates from theory for low multipoles < 4 .

¹³⁷³ <http://lambda.gsfc.nasa.gov/>

Music Analogy:

Just as the sound vibrations of a drum may be expressed as a combination of its harmonics, so fluctuations in the cosmic background radiation may be expressed as combinations of the vibrational modes of space itself. When the level of fluctuations is plotted as a function of angle, we find a characteristic of spatial geometry over all time. The position of maxima in the angular spectrum is described by their wave number or mode $l = 180^\circ/\theta$, where θ is the angular distance in the sky. The lowest mode - the dipole or $l = 1$ mode - is undetectable, swamped by the far stronger dipole. The first observable mode, the $l = 2$ or quadrupole mode, was seven times weaker than the predictions for a flat, infinite universe. The octopole or $l = 3$ mode was also less than the expected value by a factor of about two-thirds. For higher modes up to $l = 900$, corresponding to angular scales of just 0.2° , the Wilkinson Microwave Anisotropy Probe data are fairly consistent with the standard model. But the distribution of temperature fluctuations is not fully isotropic and the fluctuations are distributed differently on different angular scales. The unusually low amplitudes of the quadrupole and octopole modes means that long wavelengths (i.e. temperature fluctuations over large angular scales) are missing, possibly because space is not big enough to sustain them, like vibrations of a string fixed at both ends, where the maximum wavelength is twice the string length. In a stringed musical instrument this would mean that the low bass notes would be missing. Only with a very long string, of “infinite” length, would all harmonics be fully represented.

The straightforward geometrical explanation of the power spectrum implies that we live in a finite space that is smaller than we currently observe. There is also evidence that the shape of the spectrum might reflect local conditions because there are differences between northern and southern galactic hemispheres and the largest fluctuations are in the solar system plane.

From Dr Max Tegmark, of the University of Pennsylvania, CMB analyst:

The entire observable Universe is inside this sphere, with us at the **center** of it....We found something very bizarre; there is some extra, so far unexplained structure in the Cosmic Microwave Background...We had expected that the microwave background would be truly isotropic, with no preferred direction in space but that may not be the case. The octopole and quadrupole components are arranged in a straight line across the sky, along a kind of cosmic equator. That’s weird... We don’t think this is due to foreground contamination. It could be telling us something about the shape of space on the largest scales. We did not expect this and cannot yet explain it.

Interpretation:

The undersized multipoles for $l < 4$ (low multipole cutoff) indicate that the universe is cut-off at large distances, which means a cosmos that is finite in space! It cannot be bigger than now observed in the Cosmic Microwave Background sky.

The correlation of the normals with the ecliptic poles suggest an unknown source or sink of Cosmic Microwave Background radiation. If it is a physical source or sink in the inner solar system, it would cause an annual temporal modulation or appear in polarization maps. So we must look deeper into space.

Physical correlation of the Cosmic Microwave Background with the equinoxes is hard to explain, since the Wilkinson Microwave Anisotropy Probe satellite has no knowledge of the inclination of the Earth's spin axis. Whence these correlations?

The correct explanation of these unexpected Cosmic Microwave Background correlations is currently not known. There are four possibilities:

- (1) There is a systematic error (an error in the data analysis or instrument modeling).
- (2) The source is astrophysical (i.e. an unexpected foreground).
- (3) It is cosmological in nature (e.g. an anisotropic universe with nontrivial topology).
- (4) The observed correlations are a pure statistical fluke.

A statistical fluke can be eliminated, based on the high confidence levels and the varying independent data sets and analysts. If indeed the $l = 2, 3$, Cosmic Microwave Background fluctuations are inconsistent with the predictions of standard cosmology, then one must reconsider all Cosmic Microwave Background results within the standard paradigm which rely on low l 's.

Suggestions for the cause of the preferred $l = 2, 3$ axis:

- (1) A feature of a non-trivial cosmic topology. For example, a universe with a football or doughnut/torus shape, the symmetry axis being the observed direction.
- (2) Anisotropic Big Bang expansion, i.e, different speeds in different directions.
- (3) Intrinsic cosmic inhomogeneity, basically, the ether as a euphemism.
- (4) The universe is really rotating, making the rotation axis different from other directions.

Geocentrism:

The cosmological principle assumes that the universe is the same in all places and directions; otherwise, it would be impossible to solve Einstein's equations. If this assumption is wrong, the standard Big Bang model of cosmology would be unusable.

The Cosmic Microwave Background octupole and quadrupole components were expected to form no pattern at all, but the results were anything but random. If the multipole vectors of the quadrupole and the octupole are correlated with the ecliptic poles, the axis at 90° to the solar system plane and with the dipole direction, then this suggests that the large wavelengths/low frequencies are missing because we are seeing the influence of the solar system environment, not the global properties of space. And we see these missing features because of our privileged position in the center of space. As might be expected from past history, despite these totally unpredicted and unexplained anomalies, the Cosmic Microwave Background data is regarded as a dramatic confirmation of standard inflationary cosmology! In fact, the axial correlation between multipole harmonics has been dubbed the "Axis of Evil." The combination of a complete lack of any known systematic error, and long odds against random alignment that has earned the low-alignment anomaly this nickname. Why is the axis called "evil"? Because it represents a return to the forbidden days of five centuries ago, when all science was geocentric/geostatic. It is the plain indication of an inherently inhomogeneous and anisotropic universe.

If its causes are of both deep space and local origin, the explanation might be found in an interaction of local structures with the deep space source(s) of the ether. Conventional physicists assume the dipole comes from the solar system motion through the Cosmic Microwave Background rest frame. Not being of cosmic origin, they subtract the Cosmic Microwave Background dipole moment from computations of all other multipoles. This throws the baby out with the bathwater. The dipole is 1000 times stronger than any other pole; it points to the source of the Cosmic Microwave Background energy.

The largest signal in the Cosmic Microwave Background anisotropy is the dipole, 3.346 mK in the direction ($l = 264$, $b = 48$) in galactic coordinates. This is attributed to the motion of the sun at 370 km/s with respect to the rest frame defined by the Cosmic Microwave Background. The solar motion implies the presence of a kinematically induced Doppler quadrupole. This is an artifact of the antigeocentric premise: if the multipole hot spots indicate the ether source(s) in the cosmos then the multipoles have nothing to do with the kinematics of matter. Doesn't anyone realize that the universal Cosmic Microwave Background has local axial and planar symmetries only when viewed from Earth? Doesn't any scientist on this planet realize that it isn't a planet? When will our stiff-necked scientists bow their heads and

acknowledge the elephant in the living room, the emperor with no clothes?

The tiny and tall,
The big and the small,
The Lord God Almighty,
He alone made it all!

Galaev (1998):

A tube is placed into a gas stream perpendicular to the stream direction. With no pressure drop across the tube the gas inside the tube will be static. The tube is rotated 90° so the gas stream is along the tube axis, causing a pressure drop and gas motion. See below.

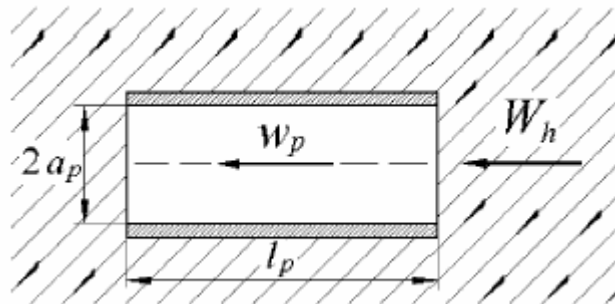

Tube and gas flow parallel¹³⁷⁴

W_h is the horizontal ether speed component outside the pipe, W_p inside the pipe, a and l_p are the pipe's radius and length. The ether flow is shown as slanting thin vectors. The metal tube walls have major ether-dynamic resistance, when the ether flow is normal to the tube axis, the interior ether flow is minimal. The ether velocity caused by the horizontal velocity, W_h , creates the ether flow in the tube, having mean velocity W_p . The tube is a channel for the ether stream that will be treated by the laws of viscous liquid hydrodynamics. The time to reach steady-state conditions depends on the kinematic ether viscosity, the tube size and the velocity of the exterior gas stream. The gas stream in the tube is almost uniform, with a sharp reduction to zero in a thin boundary layer near the wall. With a light beam inside the tube, and another outside in the exterior ether flow, turning the tube at a right angle will form an interference pattern, after stabilization, by combining the two beams. See below.

¹³⁷⁴ <http://home.t01.itcom.net/allais/blackprior/galaev/galaev-2.pdf> Fig 1

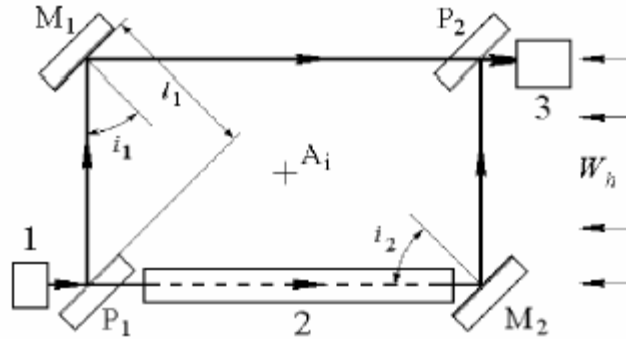

Optical interferometer layout

Source 1; tube 2; eyepiece 3; P₁, P₂ half-silver mirrors; M₁, M₂ full-silver mirrors; A_i rotation axis; l₁, i₁, i₂ as shown above¹³⁷⁵

Key principle: Since the ether velocity changes from 0 to maximum with a 90° rotation, the phase of a light wave should also change according to the time variation of the ether velocity $\mathbf{W}_p(t)$. The phase offset will be proportional to the ether exterior velocity and the stabilization time will define the ether kinematic viscosity. The light beam is divided by P₁ into two beams, which combine at P₂ with a phase difference:

$$\phi = 4\pi l_1 (\cos i_1 - \cos i_2) / \lambda$$

By geometry, the phase difference between the two beams is proportional to the small difference in the ether velocity inside the tube, $\mathbf{W}_p(t)$, and outside, \mathbf{W}_h :

$$\Delta\phi = l_p(\mathbf{W}_h - \mathbf{W}_p) / \lambda c$$

The maximum phase shift occurs when the internal ether velocity \mathbf{W}_p is zero, maximum $\Delta\phi = l_p \mathbf{W}_h / \lambda c$. Zero phase difference occurs when the ether velocities are equal inside and outside the tube. Solving the last equation for \mathbf{W}_h ,

$$\mathbf{W}_h = \lambda c \Delta\phi_{\max} / l_p$$

Substituting in the $\Delta\phi$ equation :

$$\mathbf{W}_p = \lambda c / l_p (\Delta\phi_{\max} - \Delta\phi)$$

The ether kinematic viscosity is calculated to be $7.06 \times 10^{-5} \text{ m}^2/\text{sec}$; the measured value is $6.24 \times 10^{-5} \text{ m}^2/\text{sec}$. This is within the range of real gases: $\text{CO}_2 = 7 \times 10^{-6} \text{ m}^2/\text{sec}$, $\text{He} = 1.06 \times 10^{-4} \text{ m}^2/\text{sec}$.

Summary of the result types:

¹³⁷⁵ <http://home.t01.itscom.net/allais/blackprior/galaev/galaev-2.pdf> Fig 3

- horizontal ether velocity W_h .
- a daily record of the ether drift velocity:
 - in each stellar day.
 - daily course averaged during the year by month - $W_h(S)$.
 - averaged for all measurements - $W_h(S)$.
- mean-square deflection W_h from its mean value σ_w .

The confidence interval of the measurements is 0.95. Over a year 2322 readouts were performed.

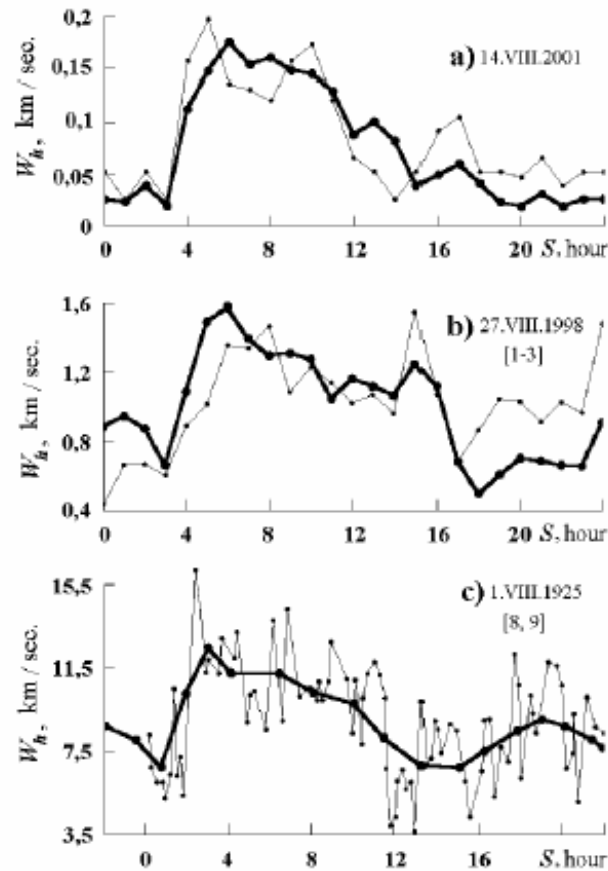
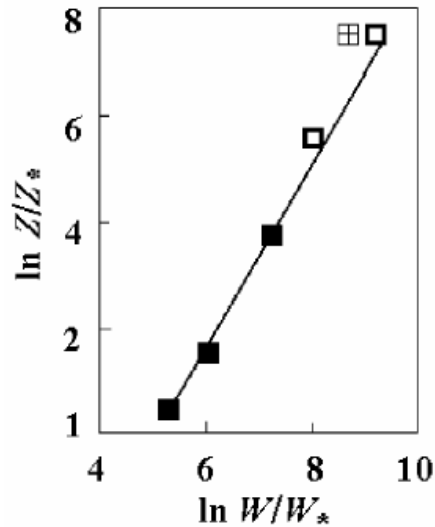

Diagram of four ether experiments all performed at various locations with three different interferometers over a period spanning 76 years – optical of order v/c in 2001, radio waves of order v/c in 1998, optical of order v^2/c^2 in 1925.

Each chart depicts ether velocity variation W_h within a stellar day in September.¹³⁷⁶ The similarity in all three patterns varying over different locations, years, equipment and protocols is undeniable. The

¹³⁷⁶ <http://home.t01.itscom.net/allais/blackprior/galaev/galaev-2.pdf> Fig 8

differing ether drift magnitude in each chart is caused by the corresponding altitudes of each interferometer: 1.6 m; 42 m; 1830 m, respectively.



Normalized dependence of the ether velocity on altitude. W is the ether velocity at the height Z . Data points are from Galaev, Miller and Michelson experiments.¹³⁷⁷

The ether velocity increases linearly with the altitude, contributing to the many null results found around sea level. At ether velocities of 200-400 m/sec, second order effects are virtually undetectable. Second order sensitivity to the ether drift is 6 powers of ten lower than first order. The four experiments independently support the linear dependence of ether speed with height.

¹³⁷⁷ <http://home.t01.itscom.net/allais/blackprior/galaev/galaev-2.pdf> Fig 9

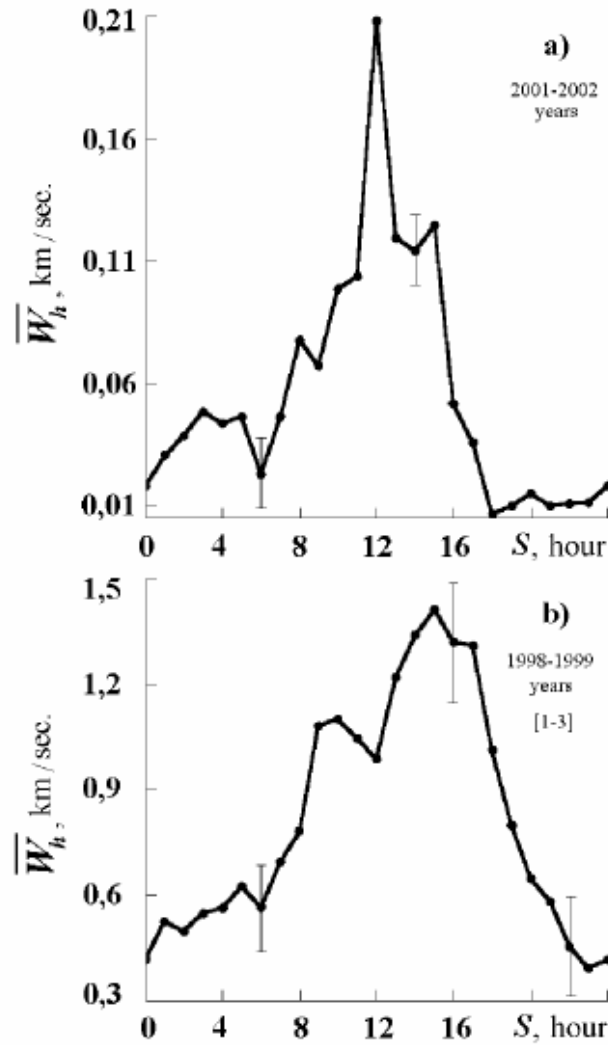

Mean daily record of the ether velocity¹³⁷⁸

There is an annual as well as daily sidereal variation. Both parts of the diagram have similar features to the ether velocity variation within a day. Differences in the two shapes can be caused by viscous ether flow interaction with the local structures and terrain. In the top chart the ether drift velocities are smaller because of the lower altitude. Ether speed exhibits periodic changes over a stellar day, implying a cosmic origin for the ether. Since the speed of light c depends on the motion of its carrier, c will also fluctuate with a period of one stellar day. Light speed will also depend on its direction in the ether and increase with altitude above the Earth's surface.

¹³⁷⁸ <http://home.t01.itscom.net/allais/blackprior/galaev/galaev-2.pdf> Fig 10

Highlights:

- The ether drift data refuted a stationary medium.
- The Earth's orbital ether drift around the Sun at 30 km/sec was not detected.
- The comparison of the suspected ether drift results with other experiments, compensating for latitudes and heights above sea level, finds them in agreement.
- Annual reproducibility: Systematic measurements in months of the year matching the same months of past experiments compare favorably to the corresponding results of these past experiments.
- The old experiments that are second order in v/c are 10,000 times less accurate than modern experiments that are first order in v/c .
- Atsukovsky estimates the sound velocity in ether to be 10^{21} m/sec, which exceeds the speed of light by $> 10^{12}$ -- more than a trillion times faster.
- The daily variation of fringe pattern corresponded those variations measured in prior experiments within a 24-hour time frame.
- Measurements with radio wavelengths show a rather small horizontal ether component during part of a day.
- Interferometer measurements are proportional to a vertical velocity gradient for the ether motion near the Earth's surface. This gradient value is proportional to the ether drift velocity (to first order).
- Horizontal ether velocity changes measured in the same month of any year have similar variation within a day.

The primary comparison is with Miller's 1925 Mt. Wilson investigation, so a summary follows.

Miller experiments:

Location	Altitude	Raw ether drift in km/sec
Cleveland	265 m.	3
Mount Wilson	1830 m.	10

Miller ether direction coordinates: [RA 17.5 hr, dec + 65°]
 compared to the ecliptic North pole: [RA 18 hr, dec.+ 66°]

Miller concluded the ether flow has a galactic (space) origin and the speed was more than 200 km/sec, but he could not explain decrease from 200 to 10 km/sec.

Premises:

Ether originates in space with a vertical velocity gradient near the Earth's surface due to ether viscosity. The mean value of the maximal gradient equals 8.6 (m/sec)/m. The change of ether drift boundary layer with height is due to the relative movement of the solar system and the ether near the Earth's surface. Note: not due to the Earth's rotation! The analysis will use Galilean relativity: light speed for the observer is the velocity relative to the ether plus the ether velocity with regard to the observer.

Experimental problems:

Miller showed that null result Michelson-Morely experiments running inside hermetic metallic chambers diminish the ether they were trying to measure. Mt. Wilson was done in an open structure; Miller recommended minimal shielding for success in ether detection. But later experiments using resonators, masers and Mossbauer effect again used massive metallic chambers or lead shields for gamma ray protection - a common instrumental error of these experiments. Michelson's two-way interferometer of the second order is insensitive to the ether streams and too sensitive to the environment.

Four factors affecting the ether flow were distinguished:

1. Anisotropy: depends on light beam direction relative to the solar system and the ether flow.
2. Altitude: above the Earth's surface/sea level, caused by surface interaction with the viscous ether flow.
3. Cosmic: variation period of one stellar day, caused by a cosmic (galactic) source.
4. Hydro-aerodynamics → ether-dynamics: motion of the viscous gas-like ether within the confinement housings, caused by solids

interacting with the ether. The height effect is partially dependent on ether dynamics.

Ether properties:

- a material medium, responsible for electromagnetic wave propagation.
- similar to a viscous gas.
- metals have major ether-dynamic resistance.

Ether viscosity:

Viscosity measurement is of particular interest, as the experimental data for ether viscosity and its measuring methods have not been described in physics literature up to date. The kinematic viscosity values, calculated and measured, give a basis to consider that the ether stream is similar to real known gases in its interaction with solids, in passing around obstacles and moving through pipes. Solids interacting with the ether flow should encounter major ether-dynamic resistance. The interferometer test shows that a dielectric tube can channel the ether as well as the metal tube. The inability of ether flow to pass through obstacles explains the unsuccessful prior attempts to detect the ether drift with enclosed interferometers.

Pioneer 10, 11 anomaly

1972 - 2004 update

Description:



Pioneer 10¹³⁷⁹

The Pioneer anomaly/effect is the measured deviation from trajectory models of various unmanned spacecraft visiting the outer solar system, notably Pioneer 10 and 11. Doppler tracking data from the Pioneer 10/11 spacecraft from between 20-70 AU, yields an unambiguous and independently confirmed anomalous blueshift drift of $2.92 \pm 0.44 \times 10^{-18} \text{ s/s}^2$. It can be interpreted as being due to a constant acceleration of $a_p = (8.74 \pm 1.33) \times 10^{-8} \text{ cm/s}^2$ directed towards the sun. No systematic effect has been able to explain the anomaly as of 2005.

The Pioneer 10 data spans 11 years; Pioneer 11 spans 4 years. At 20 AU, the spacecraft was sufficiently far from the sun for the pressure of solar radiation to have dropped to a level where the 252 kilogram probe could no longer be accelerated by the pressure. A systematic error then became apparent, an unexplained acceleration directed towards the sun that has been present ever since in all four spacecraft – the two Pioneers, Galileo and Ulysses. Although the data from the Galileo and Ulysses spacecraft indicate a similar effect, their design, spin-stabilization and proximity to the sun do not favor easy detection. Should the anomaly not be a force but rather a cause that affects all frequency standards, accelerometers will be ineffective in discovering the nature of the observed anomaly. There are no current space missions that are expected to provide useful data.

¹³⁷⁹ NASA

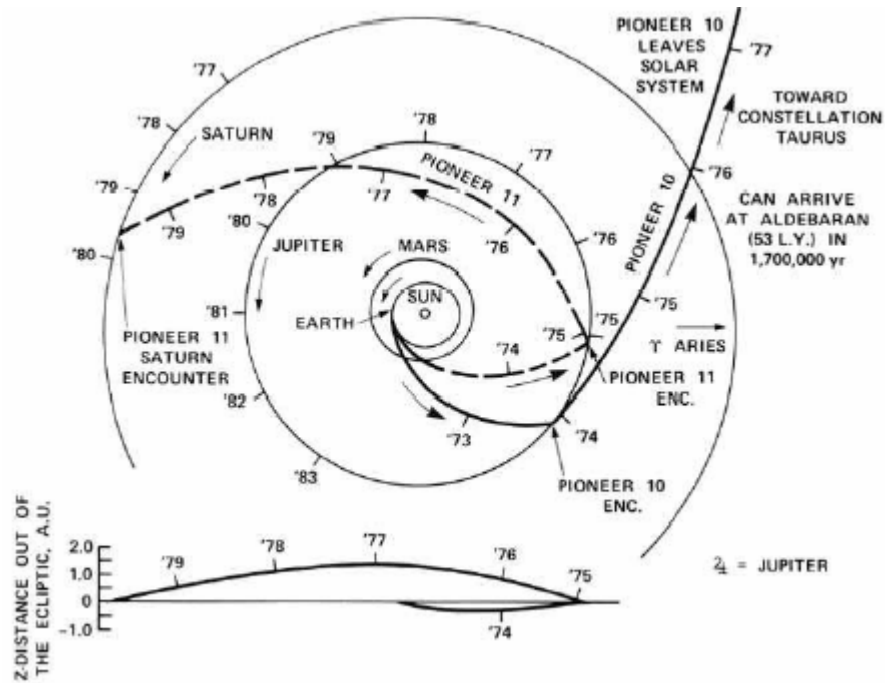

Summary of the Pioneer orbits in the interior of the solar system.¹³⁸⁰

Details of the effect:

1. The Voyager data was too coarse for testing.
2. Large, bound astronomical bodies show no signs of the anomaly, although the acceleration is too large to have escaped detection in planetary orbits, particularly for Earth and Mars.
3. The fundamental problem is measured as a Doppler shift; the delta in acceleration is inferred by holding c constant.
4. The range of the anomaly is unknown; it is basically constant between 20 and 70 AU. (NB: an AU (Astronomical Unit) is the Earth-sun distance, about 92 million miles)
5. It was masked by the larger solar wind acceleration until reaching 20 AU.
6. The direction of the acceleration is assumed to be towards the sun, but the resolution does not permit this assertion. It is possible that the acceleration is: (a) toward the Earth; (b) along the direction of motion, or (c) along the spin axis.
7. The actual direction indicates a physical origin that could be: (a) new dynamical physics originating from the sun; (b) a time signal

¹³⁸⁰ http://arxiv.org/PS_cache/gr-qc/pdf/0507/0507052.pdf Fig. 1

- anomaly; (c) a drag or inertial effect; (d) a property of the ether flow in the outer solar system; (e) an on-board systematic defect.
8. When all systematic factors common to all four craft are taken into account, the anomaly still remains.
 9. A Voyager-type space-craft is not appropriate; its frequent attitude-control maneuvers overwhelm any small external acceleration.
 10. Ulysses data analysis discloses an unmodeled acceleration towards the Sun of $(12 \pm 3) \times 10^{-8} \text{ cm/s}^2$, about 50% higher than the Pioneer anomaly.
 11. Viking ranging data accuracy limits any unmodeled radial acceleration acting on Earth and Mars to no more than $0.1 \times 10^{-8} \text{ cm/s}^2$.
 12. Ranging data are independent of the Doppler shift; they are found from signal time delay calculations of the motion are made on the basis of the range time-delay and/or the Doppler shift in the signals.
 13. Despite large solar radiation effects, the nominal value obtained for the Galileo spacecraft by measurement was $\sim 8 \times 10^{-8} \text{ cm/s}^2$, comparable to the Pioneer values.
 14. The a_p stays approximately constant for a long period (Pioneer 10 is now past 70 AU).
 15. The Pioneer anomalous acceleration contradicts the accurately known motion of the inner planets.

Suggestions/interpretations:

- A gravitational frequency shift of Pioneer signals proportional to distance and the density of the interplanetary dust cannot be responsible for the anomaly; known properties of the dust are not large enough to produce the observed acceleration.
- The effects of dark matter or modified gravity fail because observable effects that should be seen on the orbits and distances of the planets are not seen.
- Possible problems with atomic clocks have been eliminated as a cause.
- The predominant opinion of a thrust from gas leakage does not explain why the leakage from four independent craft of three different designs has the same effect.
- Proposed missions to provide useful data include using two craft near Saturn at wide angles to pinpoint the effect direction by signal interferometry.
- internal systematic properties, undiscovered because of identical design.
- a viscous drag force proportional to the velocity of the Pioneers.
- Unknown mass distribution in the outer solar system.

The possibility of a new paradigm, or the reinstatement of an old one, may be in the offing.

C anisotropy:

The basic experimental observable is a Doppler frequency shift. If f_o refers to the observed frequency, f_m refers to the frequency predicted from theoretical models and f_r is the reference frequency, then:

$$f_o - f_m = -f_r (2at/c) = -f_r (2v/c)$$

The frequency has been measured as decreasing at 6×10^{-9} hertz per second or 1.5 Hz over a period of 8 years. Since t and c are known, the non-Newtonian acceleration a has been the suspect. But the possibility of c changing with the ether density or flow has not been addressed. The behavior of the space probes provides dynamic information on the dependency of light speed on the ether of interplanetary space. The Pioneers are, in effect, mapping the solar system ether flow.

Measurements actually indicate that the observed Doppler frequency, f_o , is dropping with time. Let's solve for f_o from the above equation,

$$f_o = f_m - f_r (2at/c) = f_m - f_r (2v/c)$$

Since f_m remains unchanged, a decrease in observed frequency will occur with an increase in $f_r (2v/c)$ or a decrease in c . So a change in a or in c will cause the Pioneer effect.

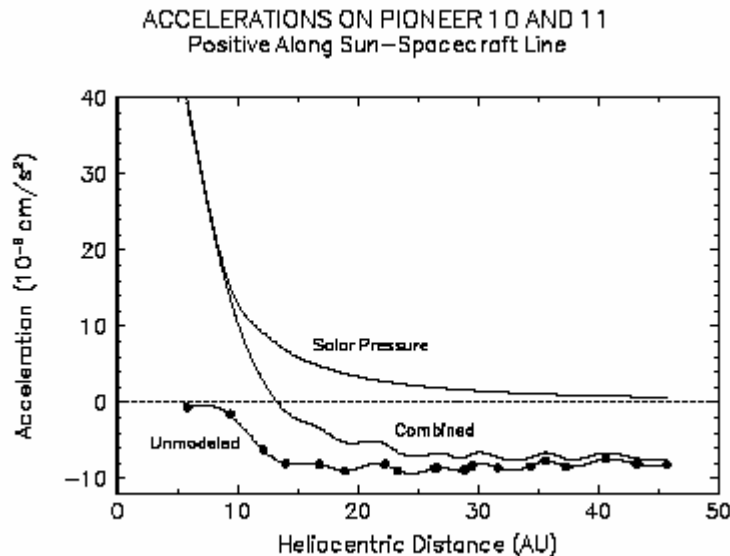

Pioneer accelerations vs. distance from the sun.¹³⁸¹

The accelerations are:

- a) the calculated solar radiation acceleration (top line),
- b) the unmodeled acceleration (bottom line), and
- c) the measured combined acceleration (middle line)

Subtraction of the measured acceleration from the solar wind/radiation pressure gives the unknown anomalous acceleration. The solar radiation pressure decreases as the inverse square, $1/r^2$.

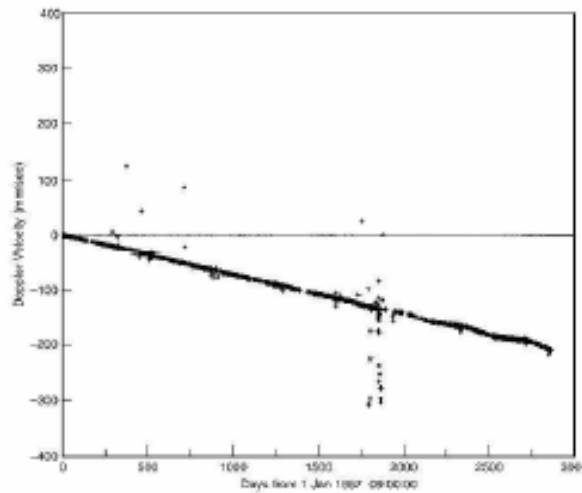

Observed Doppler velocity minus model Doppler velocity for Pioneer 10 vs. time.¹³⁸²

The slope of the long term plot of velocity versus time above visually demonstrates that the acceleration is negative and constant. The drift is clear, definite, and cannot be removed without either adding acceleration, a_p , or the inclusion of a frequency drift or clock acceleration, at .

¹³⁸¹ http://arxiv.org/PS_cache/gr-qc/pdf/0104/0104064.pdf Fig.3

¹³⁸² http://arxiv.org/PS_cache/gr-qc/pdf/0104/0104064.pdf Fig.6

Periodic variations:

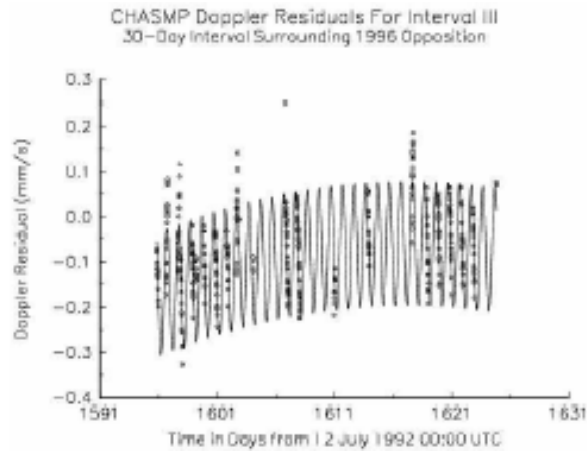

Periodic Doppler shifts over 30 day interval¹³⁸³

A pattern now becoming familiar: a short-term diurnal sine wave within an oscillating long term envelope. The data lacks the details to separate out either diurnal (solar day) from sidereal day, or to determine the direction of the source. The odds are on the Virgo-Leo cluster for the sidereal direction and the ecliptic normal for the annual variation.

An anomalous oscillatory annual term, smaller in size than the anomalous acceleration a_P , has been found by using a 1-day average over all 11.5 years, yielding:

$$a_A = (7.77 \pm 0.16) \times 10^{-8} \text{ cm/s}^2$$

for the added annual oscillation. The presence of the small annual term on top of the complete solution is apparent in the graphic above. If approximated by a simple sine wave, the amplitude of the annual sinusoid is about $1.6 \times 10^{-8} \text{ cm/s}^2$. Two different programs were independently able to produce similar post-fit residuals, giving confidence in the solutions.

A least-squares fit to an annual sine wave produced:

Amplitude v	$0.1053 \pm 0.0107 \text{ mm/s}$
Phase	5.3 ± 7.2
Angular velocity ω	$0.0177 \pm 0.0001 \text{ rad/day}$
Bias/offset	$0.0720 \pm 0.0082 \text{ mm/s}$

¹³⁸³ http://arxiv.org/PS_cache/gr-qc/pdf/0104/0104064.pdf Fig.18

The amplitude v and angular velocity ω of the annual term results in a small acceleration amplitude of $a = v\omega = (0.215 \pm 0.022) \times 10^{-8} \text{ cm/s}^2$. As seen above, there is a significant diurnal term in the Doppler residuals, with period approximately equal to the Earth's sidereal rotation period. The diurnal amplitude is comparable to that in the annual oscillation, but the angular velocity is 366 times larger. So the magnitude of the apparent angular acceleration, $(100.1 \pm 7.9) \times 10^{-8} \text{ cm/s}^2$, is large compared to a_p . The best estimate of the amplitude of the Pioneer 10 sine wave is $(0.525 \pm 0.155) \times 10^{-8} \text{ cm/s}^2$ and that of the Pioneer 11 wave is $(0.498 \pm 0.176) \times 10^{-8} \text{ cm/s}^2$. The difference in phase between the Pioneer 10 and Pioneer 11 waves is 173.2, similar to the angular separation of the two spacecraft in ecliptic longitude. The amplitudes are in the same proportion as the cosines of the ecliptic latitudes for the two spacecraft. Are the annual and diurnal terms caused by a misalignment of the Pioneer orbits on the ecliptic?

Still, the characteristic signature of a_p is a linear drift in the Doppler frequency, not the annual/diurnal features.

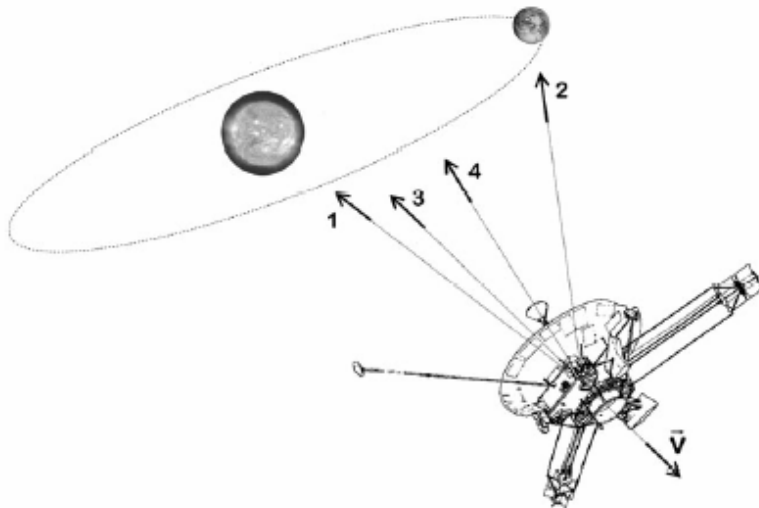

Direction of average acceleration¹³⁸⁴

Four possible directions for the Pioneer anomaly:

- (1) towards the Sun,
- (2) towards the Earth,
- (3) along the direction of motion,
- (4) along the spin axis.

¹³⁸⁴ http://xxx.lanl.gov/PS_cache/gr-qc/pdf/0308/0308017.pdf Fig 3

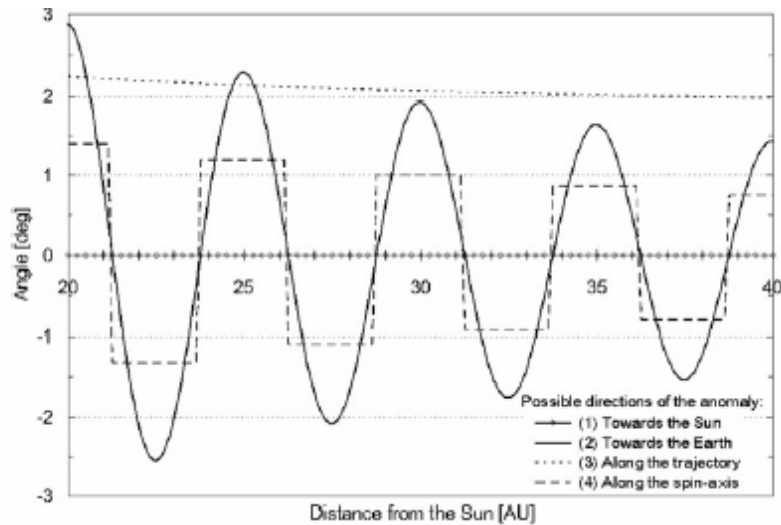

Characteristics of four possible directions of the anomalous acceleration. The signatures are distinctively different.¹³⁸⁵

At 20 AU, the angle between sun and Earth is only three degrees, which is the maximum angle subtended by the sun and the Earth. The average angle is $<$ one degree. With the radiation pattern of the Pioneer antenna and the lack of precise 3D navigation, the determination of the exact direction of the anomaly is difficult. Without an improved antennae and navigation the following directions are indistinguishable:

- (1) towards the sun
- (2) towards the Earth
- (3) along the direction of motion of the craft
- (4) along the spin axis

This suggests, for each respective direction, the corresponding inference:

- (1) new dynamical physics originating from the Sun
 - (2) a time signal anomaly
 - (3) a drag or inertial effect, or
 - (4) an on-board systematic
- The angle from the sun (1) to the trajectory line is fixed.
 - The angle towards the Earth (2) is a cosine curve formed by its orbit that is modified by a $1/r$ envelope as the craft moves further out. If the anomaly is directed towards the Earth (2), the current accuracy of the Earth's ephemeris and a sinusoid signal will be essential to determine this.

¹³⁸⁵ http://xxx.lanl.gov/PS_cache/gr-qc/pdf/0308/0308017.pdf Fig 4

- An almost-linear angular change approaching the direction of the Sun would indicate a path-related source for the anomaly (3)
- The direction along the spin axis (4) is a series of decreasing step functions, created by the orientation maneuvers.

These four possible anomaly directions all have different characteristics. A future space mission dedicated to resolving the direction of the anomaly should be able to resolve the direction uncertainty.

Claims and Responses:

Claim #1: The angle towards the Earth is a cosine curve formed by its orbit. If this cosine variation is observed, the conclusion is that the anomaly is pointed at the Earth, not the sun.

Response: No. There is a metaphysical assumption here that the Earth moves around the Sun. The reality is that the Earth is fixed, so no variation in direction should be seen. It is the sun that should display a sinusoid curve, in its motion around the Earth. This is a good example of how false cosmic premises compound conceptual errors. The erroneous interpretation of the results will be taken as more proof of a fixed sun and an Earth in orbit around it.

Claim #2: The Pioneer mystery was attributed to a possible “anomalous” acceleration (new physics!), directed toward the sun for both spacecraft.

Response: But if the Pioneer signal travels faster in the ether of space, due to either a change in its density or speed, the frequency shift/acceleration would be a consequence of the change in c .

Claim #3: The position of a spacecraft is found by examining the diurnal variation imparted to the Doppler shift by the Earth’s rotation.

Response: Or the effect of the ether rotational flow on the spacecraft!

Claim #4: As the ground station rotates underneath a spacecraft, the Doppler shift is modulated by a sinusoid.

Response: Or the ether rotates between the two!

Claim #5: If the Pioneers are simulating the rotating Earth as in Foucault’s experiment, a coordinate transformation to the Cosmic Microwave Background rest frame would entirely remove the Pioneer effect.

Response: No. The effect is absolute, due to the ether, and would be seen in any frame.

Claim #6: The annual and diurnal terms are likely different manifestations of the same modeling problem whose sources are both Earth-related.

Response: The terms are manifestations of an ether that flows through space. The Earth is related to these terms via the ether.

Conclusion

Since the speed of light proves not to be a universal constant, being subject to variation by daily, seasonal and other periodic effects, the credibility of Relativity should collapse like a house of cards. But there are too many with interests and egos vested in Relativity – so it is propped up with *ad hoc*, just so, and contradictory supports. But a house built on sand cannot stand the storm of contrary evidence. Nothing strikes fear into the heart of ardent relativists more than experiments that detect “sidereal” variations in terrestrial measurements.

The logic is terrifying: How can the stars produce periodic waves every 24 hrs – 4 min if not moving themselves at that rate? If it is the sun’s gravitational force lines that we rotate through each day, it should repeat exactly every 24 hours, not 23 hours and 56 minutes. What an important 240 sec!

Present popular theories regarding the rotation of the Milky Way Galaxy cannot be correct! Their reasoning requires our sun to be traveling in a relatively circular orbit, which means that we would have to be traveling toward a direction that is very close to 90° away from where the core of the Galaxy really is: [R.A. 17h. 45m. Decl. -29°]. That is not the case! The sun is actually traveling in a direction toward Hercules [R.A.18h Dec. +29°] at 20 km/sec (Wilson, 1911). This is about 32° away from an orbital path in the Milky Way!

The crucial tests are the disproofs, the tests that rated an X in explaining the results in the foregoing charts. Using unbiased logic and no ideological prejudices (in the sense that a stationary Earth is not not excluded metaphysically as an option for explanation) the tests show that the predictions/claims of:

- Heliocentrism are challenged 23 times,
- Special Relativity 40 times, and
- General Relativity 35 times.
- Geocentrism is never eliminated, in any test.

Despite this scientific analysis, the rejection of geocentrism will continue until reason returns. There are scientists today who have boldly rejected the speculation of Relativity and found, as this chapter has, that experiments consistently disprove its principles, even when wrapped in mathematical legerdemain. But they will not, they cannot, shake off the mistakes of the past until they return to the belief of the ancients in a *terra* that is truly *firma*.

Appendices

Appendix 1

Anomalies Concerning the Speed of Light

Although it is still an open question, there have been a number of experiments and calculations done over the last few decades suggesting that light's speed has been steadily decreasing. As early as 1927, *Science* carried an article,¹³⁸⁶ and in 1931 and 1934 *Nature* carried two articles,¹³⁸⁷ citing the work of M. Gheury de Bray in *L'Astronomie*, which showed from statistics taken since 1849 that light was slowing down by four kilometers per second every year. In 1849 light registered a speed of 313,300 km/sec, and by 1933 it was 299,774 km/sec, a difference of 13,526 km/sec over 84 years. These tests were all done by mechanical apparatus.

In 1932 physicist Arthur Lynch reported: "In 1902 Perrotin gave $299,901 \pm 84$ km/sec.; in 1924 Michelson found $299,802 \pm 30$ km/sec. And in 1926, $299,796 \pm 4$ km/sec.; in 1928 Karolus and Mittelstaedt found $299,778 \pm 20$ km/sec.," and that de Bray attributed the decrease to the magnetic field of the Earth.¹³⁸⁸

In 1987 two Australian scientists, Trevor Norman and Barry Setterfield catalogued one of the more detailed studies of the decrease of light's speed over a period of many decades, concluding that the data indicated that light's speed in the past may have been as high as 10 billion times more than it is now.¹³⁸⁹ Russian cosmologist V. S. Troitskii from the Radiophysical Research Institute in Gorky reached the same conclusion.¹³⁹⁰ Norman and Setterfield's results were doubted, however, when decreases in light's speed were not observed after 1960 when the measuring was performed by atomic clocks. Setterfield explained the difference by positing that since atomic frequencies were also decreasing by the same decay factor as light's speed, they would not be able to detect the decrease in light's speed, whereas mechanical apparatus could still do so. Supporting Setterfield, other studies show that atomic

¹³⁸⁶ "The Velocity of Light," *Science*, Vol. 66, Supp. X, Sept. 30, 1927.

¹³⁸⁷ "The Velocity of Light," *Nature*, April 4, 1931, p. 522; March 24, 1934, p. 464.

¹³⁸⁸ *The Case Against Einstein*, p. 137.

¹³⁸⁹ *The Atomic Constants, Light and Time*, self-published, 1987.

¹³⁹⁰ "Physical Constants and the Evolution of the Universe," *Astrophysics and Space Science*, Vol. 139, No. 2, Dec 1987, pp. 389-411.

frequencies are decreasing.¹³⁹¹ Setterfield also holds that quantized redshift patterns, measured changes in atomic masses, and Planck's constant over time, are also part and parcel with the slowing down of light.¹³⁹²

As the foregoing evidence suggests that light's speed has been slowing down diachronically, other evidence suggests that light's speed is not constant synchronically. One highly reputable source of such evidence is the Global Positioning System. Two experts in the field have written at length concerning this anomaly. Wang and Hatch write:

Contrary to the assertion of Special Relativity, the speed of light is not always constant relative to a moving observer. The Global Positioning System (GPS) shows that the speed of light in the Earth Centered Inertial (ECI) non-rotating frame remains at c relative to the frame – but not relative to an observer or receiver moving in that frame. When a GPS receiver changes its translation speed relative to the ECI frame, the speed of light measured relative to the receiver changes....The calculation using the GPS range equation and the results of a Real-Time Kinematic (RTK) differential GPS test have shown that the constancy of the speed of light relative to moving airplanes is not correct. The change of the time difference could reach about 10 ns for subsonic airplanes and 30 ns for supersonic airplanes....In the GPS system, when the observer is moving relative to the center of the earth, the speed of light relative to that observer is not equal to cThe speed of light is not always c relative to a moving observer (receiver). Instead, the speed of light is always c relative to the chosen inertial (isotropic light speed) frame....This is also evidenced by the JPL [Jet Propulsion Lab] space probe equations...

Relativistic physicists claim that people who refuse to accept the constancy of the speed of light simply cannot give up their common sense acquired through slow speed experiences. However, this is not true. Human beings are intelligent and they are flexible as well. Once people have been exposed to solid experimental facts, they are willing to adopt new ideas. The common sense that a falling body descends at a rate that is proportional to its weight has changed to the common sense that, if there is no air resistance, all bodies fall at the same rate.

¹³⁹¹ Alan Montgomery and Lambert Dolphin, "Is the Velocity of Light Constant in Time?" *Galilean Electrodynamics*, Vol. 4, No. 5, Sept-Oct 1993, pp. 93-97.

¹³⁹² Of the accepted physical constants, Setterfield found that, with a decrease in the speed of light, nine of the constants remained the same (Avogadro's number, Boltzman's constant, electron charge, energy, fine structure constant, gas constant, permittivity, Bohr megneton, Rydberg constant); four increased (effective mass, h/q ratio, permeability, Planck's constant); two decreased (gyromagnetic ratio, specific charge). Setterfield found that every one of the seventeen constants followed the decay pattern of the speed of light.

This change in perception is a direct result of the experimental data. The reason some do not believe in the constancy of the speed of light relative to a moving observer is in fact that there are experimental facts which indicate otherwise.¹³⁹³

Other physicists who questioned Einstein's postulate on light were Parry Moon and Domina Spencer, pioneers in the science of radiosity. Basing their thesis on the concept that physical properties must be demonstrated in Euclidean terms, Moon and Spencer advanced the idea that the velocity of light was dependent on a more important postulate, universal time, the antithesis to Einstein's concept of relative or local time. Spencer compares her results with the 1905 and 1907 Einstein postulates and Ritz's 1908 postulate. Her peer-reviewed experiments are consistent with the universal time postulate in a Euclidean space and with the discovery that both the 1905 and 1907 Einstein postulates are inconsistent with some of the experiments. The Ritz postulate is incompatible with the astronomical data on the binary stars unless it is assumed that space is Reimannian rather than Euclidean.¹³⁹⁴

¹³⁹³ Ruyong Wang and Ronald R. Hatch, *Conducting a Crucial Experiment of the Constancy of the Speed of Light Using GPS*, ION GPS 58th Annual Meeting / CIGTF 21st Guidance Test Symposium, 2002, pp. 495-505. The authors continue: "A crucial experiment of the constancy of the speed of light relative to a moving receiver could be conducted in the following way: Let two GPS satellites and two airplanes be positioned in a straight line. Let the two airplanes travel at the same speed directly toward one of the two satellites and directly away from the other satellite. The travel time differences of GPS signals arriving at the two airplanes is measured and recorded with the airplanes flying first toward one of the satellites and then flying the opposite direction toward the other satellite. The travel time differences obtained as the airplanes fly in opposite directions are compared. If the travel time difference is the same when the velocity of the airplanes is changed, then the speed of light is indeed constant relative to the moving airplanes, otherwise it is not."

¹³⁹⁴ In the paper "A New Interpretation of the Hefele-Keating Experiment," Spencer points out that Einstein found it necessary to change his 1905 postulate on the speed of light in 1907 to: "The velocity of light in free space is a constant c irrespective of the velocity of source or receiver in any coordinate system which is not in rotation" (A. Einstein, "Über das Relativitätsprinzip und die aus demselben gezogenen Folgerungen," *Jahrbuch der Radioaktivität*, IV, pp. 422-462, V, pp. 98-99, *Berichtigungen*, 1907). Spencer holds that due to their results in stellar aberration experiments in 1996, Einstein's revised Postulate is contradicted, and "we conclude that the only postulate on the velocity of light which correctly predicts all of the experimental results hitherto analyzed is Postulate III, the universal time postulate on the velocity of light." Postulate III is stated thus: "In a coordinate system that is not moving with respect to the source and which is not in rotation, the velocity of light in free space is a constant c ." In "Binary Stars and the Velocity of Light," Moon and Spencer write: "The principle hypothesis of special relativity is that in free space, the velocity of light is constant with respect to the observer, independent of motion of source or observer. This assumption is contrary to all human experience, and it can be included in the theory only by abolishing ordinary ideas of space and time. The

In 1982, P. Kolen and D. G. Torr showed positive results in seeking sidereal phase variations by two atomic clocks separated by 500 meters.¹³⁹⁵ In 1997, superluminal effects were noted by T. J. Pearson, *et al.*, in “Superluminal Expansion of Quasar 3C273,” as well as Quasar 3C345 and others.¹³⁹⁶ See also Borge Nodland and John Ralston, “Indication of Anisotropy in Electromagnetic Propagation over Cosmological Distances.”¹³⁹⁷

In 1988, two experiments, one using radio waves the other electrical signals, provided evidence that light’s speed was increased by a factor of one hundred.¹³⁹⁸ In 1995, Brown and Marangos found light’s speed to be slightly exceeded.¹³⁹⁹ Another study performed by Michael Stenner, *et al.*, at Duke University and reported in *Nature* showed that the velocity of photons in potassium plasma moves faster than c .¹⁴⁰⁰ Antonio Alfonso-Faus in “Quantum Gravity and General Relativity Consistent with a Decreasing Speed of Light and Mach’s Principle” postulates that light’s slowing in cosmological time is consistent with the conservation of momentum.¹⁴⁰¹ Andrea Albrecht and João Magueijo state: “...a time varying speed of light could provide a resolution to the well-known cosmological puzzles.”¹⁴⁰² Magueijo, a theoretical physicist at Cambridge and the College of London, then wrote a book on the subject titled: *Faster than the Speed of Light*.¹⁴⁰³ Astronomer John D.

alternate assumption is that the velocity of light is constant with respect to the source, as advocated in the ‘emission theory’ of Ritz” (*Journal of the Optical Society of America*, Vol. 43, No. 8, August 1953, p. 635). See also D. Spencer and U. Y. Shama, “Stellar Aberration and Postulates on the Velocity of Light,” *Physics Essays*, 1996. See also A. Assis, *Rational Mechanics*, Apeiron Press, Montreal, Canada 1999.

¹³⁹⁵ “An Experiment to Measure the One-Way Velocity of Propagation of Electromagnetic Radiation,” *Foundations of Physics* 12, 401-411, 1982.

¹³⁹⁶ *Nature* 290:365, 1997.

¹³⁹⁷ *Physical Review Letters* 78, 16:3043, 1997.

¹³⁹⁸ P. T. Pappas and Alexis G. Obolensky, “Thirty-Six Nanoseconds Faster Than Light,” *Electronics and Wireless World*, Dec. 1988, pp. 1162-1165. Also Harold W. Milnes, “Faster Than Light?” *Radio-Electronics*, Vol. 54, Jan 1983, pp. 55-58.

¹³⁹⁹ Julian Brown, “Faster Than the Speed of Light,” *New Scientist*, April 1, 1995, pp. 26-29. Jon Marangos, “Faster Than a Speeding Photon,” *Nature*, Vol. 406, July 20, 2000, pp. 243-244.

¹⁴⁰⁰ Michael D. Stenner, Daniel J. Gauthier and Mark A. Neifeld, “The speed of information in a ‘fast-light’ optical medium,” *Nature* 425, 695-698, 2003.

¹⁴⁰¹ *Substance and Spacetime*, Vol. 3, 2002, No. 3 (13), pp. 130-131.

¹⁴⁰² “A Time Varying Speed of Light as a Solution to Cosmological Puzzles,” *Physical Review D*, Feb. 15, 1999, pp. 043516-9.

Barrow at the University of Sussex postulates the same, as does John W. Moffat of the University of Toronto.¹⁴⁰⁴ As Setterfield estimated, these scientists also came to the conclusion that the speed of light could have been ten magnitudes (10^{10}) higher than it is today. Magueijo adds that the debate should not be on why and how the speed of light could vary, but what combination of irrefutable theories demand that it be constant at all.

Doubts about Einstein's postulate of the absolute speed of light were suggested by the experiments of Raymond Chiao who found that photons, when tunneling through various kinds of barriers, seem to travel faster than photons in space.¹⁴⁰⁵ Lijun Wang of the NEC Institute expanded the phenomena by firing a pulsed laser through a chamber of cesium vapor and found that the wavefront pulse that left the chamber was 310 times faster than it would have taken a photon at standard light speed to traverse the chamber's distance. Wang commented: "...our experiment does show that the generally held misconception that 'nothing can travel faster than the speed of light' is wrong." Similar experiments had been done previously in which light achieved superluminal speeds, but the light was distorted, raising doubts as to whether scientists had really accomplished such a feat. But the laser pulse in Wang's experiment exits the chamber with no distortion but with less intensity. Wang notes that the pulse may look like a straight beam but actually behaves more like waves of light particles, and that the light can leave the chamber before it has finished entering because the cesium atoms change the properties of the light, allowing it to exit more quickly than in a vacuum. The leading edge of the light pulse has all the information needed to produce the pulse on the other end of the chamber, so the entire pulse does not need to reach the chamber for it to exit the other side. Thus, an identical light pulse is produced that exits the chamber and travels about 60 feet before the main part of the laser pulse finishes entering the chamber. Wang adds that the effect is possible only because light has no mass, that is, the same results cannot be expected from physical objects. Wang worked with Alexander Kuzmich and Arthur Dogariu and their peer-reviewed results were published in the journal *Nature*.¹⁴⁰⁶

Other anomalies with light continue to crop up. *New Scientist* reported on an experiment in 1962 referencing the work by W. Kantor of

¹⁴⁰³ João Magueijo, *Faster than the Speed of Light*, Cambridge, Mass., Perseus Publishing, 2003. Reviewed in *Scientific American*, April 2003, pp. 97-98.

¹⁴⁰⁴ "Speed of Light Slowing Down," *London Sunday Times*, Nov. 15, 1988; "Is Nothing Sacred," *New Scientist*, Vol. 163, July 24, 1999, p. 28.

¹⁴⁰⁵ D. H. Freedman, "Faster Than a Speeding Photon," *Discover*, August 1998.

¹⁴⁰⁶ L. J. Wang, A. Kuzmich and A. Dogariu, "Gain-assisted Superluminal Light Propagation," *Nature*, Volume 406, July 20, 2000.

the U.S. Navy Electronics Laboratory appearing in the *Journal of the Optical Society of America* (vol. 52, no. 8, p. 978), which indicated light's speed was dependent on its source. This was a simple experiment that split a xenon light source and measured its fringe shifts.¹⁴⁰⁷ This experiment was repeated by Babcock and Bergman¹⁴⁰⁸ and again by Rotz.¹⁴⁰⁹ Kenneth Brecher gives an alternate view in "Is the Speed of Light Independent of the Velocity of the Source?"¹⁴¹⁰

Unfortunately, many experiments occurring today to test the constancy of the speed of light make the same mistake that Michelson and Morley made over one hundred years ago. In regard to the 1887 experiment, Robert Kunzig of *Discover* magazine writes:

Because Earth orbits the sun at 18 miles per second, Michelson and Morley reasoned that they should be able to detect an ether wind blowing through their Cleveland basement...Several groups are looking for such variations with modern versions of the Michelson-Morley experiment. Peter Wolf, Sebastien Bize, and their colleagues at the Paris Observatory measure c with microwaves oscillating at 12 gigahertz inside a small sapphire crystal...If c were to change because the orientation of the crystal had changed with respect to some "preferred" direction of space [the movement of the Earth around the sun], then the resonant frequency of the sapphire oscillator would change as well...Over a period of months, as Earth spins on its axis and revolves around the sun, the Paris researchers monitor their oscillator, comparing it with the microwaves from a hydrogen maser (microwave laser), which shouldn't be affected by Earth's motion. "What we measure is that small frequency difference," says Bize. "We look for modulations that correlate with the motion of Earth."¹⁴¹¹

This description is rather interesting for several reasons. First, it is obvious that Kunzig, Wolf and Bize are basing their observations on the same unproven premise which plagued Michelson-Morley – they assume the Earth is moving. As it stands, they are going to find the same "null" result as Michelson-Morley and conclude that the speed of light is the same in all directions, and therefore constant. After a hundred years,

¹⁴⁰⁷ *New Scientist* 16:276, 1962.

¹⁴⁰⁸ *Journal of the Optical Society of America* 54, 1:44, 1964.

¹⁴⁰⁹ *Physical Letters*, 7, 4:252 (1963).

¹⁴¹⁰ *Physical Review Letters*, Vol. 39, No. 17, Oct 24, 1977, pp. 1051-1054.

¹⁴¹¹ Robert Kunzig, *Discover* contributing editor, "Testing the Limits of Einstein's Theories," September 2004, pp. 56-57.

no one seems to have caught on to the idea that the “null” result was a product of a motionless Earth. Second, the control experiment that Wolf and Bize used is a hydrogen maser that they claim “shouldn’t be affected by Earth’s motion.” This begs the question as to how a hydrogen maser will not be affected by the “Earth’s motion,” but every other light source is affected by such motion? The article does not explain. Moreover, if it is true that a hydrogen maser is not affected by the “Earth’s motion,” then the hydrogen maser should be used in all future interferometers to test whether the speed of light is truly constant. Of course, the problem would be to prove that a hydrogen maser is not affected by motion, but how can one do that if he already assumes the Earth is moving? Any test done on a hydrogen maser has Earth as its only laboratory.

Kunzig proceeds in the article to give a description of a similar experiment being performed at Humboldt University in Berlin. The results are not surprising:

Another group...uses a slightly different setup, comparing the outputs of a pair of sapphire oscillators. Over the past several years the two groups have achieved broadly comparable null results. “The speed of light in any two directions is the same to about one part in a quadrillion,” says Holger Müller...That’s equivalent to knowing the U. S. gross national product to within a penny.¹⁴¹²

Müller, of course, is basing his “null” result on the same unproven premise that Michelson-Morley and Wolf-Bize have based their result. If they already assume the Earth is moving at 30 km/sec, and if they happen to include the supposed speed of the solar system around the Milky Way at 300 km/sec, and the Milky Way around or moving toward another group of galaxy clusters at a speed of 600 km/sec, naturally, if they produce only a 1-4 km/sec result in their “sapphire oscillators” they will certainly conclude that the speed of light is unaffected, just as Michelson and Morley did. In effect, these kinds of experiments tell us nothing, except perhaps that science still uses the same prejudices and unproven assumptions to make their tallies come out as expected.

Scientific American notes:

If c varies, so, too, does the fine structure constant, α , which is a dimensionless number that specifies the strength of the electromagnetic interaction. α can be expressed in terms of c , Planck’s constant and the charge of the electron. α can therefore also change with c remaining constant,

¹⁴¹² Robert Kunzig, *Discover* contributing editor, “Testing the Limits of Einstein’s Theories,” September 2004, p. 57. Alan Kostelecký, “The Search for Relativity Violations,” subtitle: “Ancient Light,” *Scientific American*, Sept. 2004, p. 99.

which might not infringe on relativity but would be equally seismic....The possibility that alpha might change was considered as long ago as 1955, by the great Russian physicist Lev Landau. Today physicists and astronomers are looking at ancient light from distant quasars for evidence that alpha was slightly different eons ago. Changing alpha would subtly alter the frequency of light emitted or absorbed by atoms and ions.¹⁴¹³

In a related incident, Argentine scientists H. Vucetich, S. Landau and P. Sisterna suggest that if light's speed decreased this would violate the principle of charge conservation. Based on the understanding of light as a series of oscillating magnetic fields, the scientists postulate that if the speed of the wave decreases it will create a positive charge more rapidly than it can be received and sent back in the opposite direction, and thus create an imbalance by leaving positive charges along the light path.

Scientific American provided its readers with an interesting anomaly regarding the speed of light. In an article titled "The Evolution of the Universe" the authors provide the step-by-step details of how the Big Bang is supposed to have occurred. In the first paragraph, they state:

At a particular instant roughly 15 billion years ago, all the matter and energy we can observe, concentrated in a region smaller than a dime, began to expand and cool at an incredibly rapid rate. By the time the temperature had dropped to 100 million times that of the sun's core, the forces of nature assumed their present properties, and the elementary particles known as quarks roamed freely in a sea of energy. When the universe had expanded an additional 1,000 times, all the matter we can measure filled a region the size of the solar system.¹⁴¹⁴

Note here that the rate of expansion is a very important ingredient for Big Bang cosmology. It is called the Omega value. If the expansion is too slow, then the universe eventually collapses under its own weight, as it were. If the expansion is too fast, the universe goes into oblivion and cannot form any galaxies or planets. As in the story of *Goldilocks and the Three Bears*, the porridge of the Big Bang has to be "just right" or else the universe goes up in smoke. With this in mind, the authors continue in the second paragraph:

¹⁴¹³ Graham P. Collins, included in the article "The Search for Relativity Violations," *Scientific American*, Sept. 2004, p. 99.

¹⁴¹⁴ P. James E. Peebles, David N. Schramm, Edwin L. Turner and Richard G. Kron, "The Evolution of the Universe," *Scientific American*, October 1994, p. 53.

At that time, the free quarks became confined in neutrons and protons. After the universe had grown by another factor of 1,000, protons and neutrons combined to form atomic nuclei, including most of the helium and deuterium present today. All of this occurred within the first minute of the expansion.¹⁴¹⁵

So here we see that the Big Bang filled a space the size of our solar system all in the course of one minute. An observant reader to the magazine wrote in six months later and noticed an anomaly:

I encountered a problem in “The Evolution of the Universe.” It takes a little less than seven hours for light from the sun to reach the outermost planet, Pluto. According to Einstein’s Special Theory of Relativity, nothing travels faster than the speed of light. Yet the article states that “...All of this occurred within the first minute of the expansion.” What happened that allowed matter and energy to travel thousands of times faster than light?¹⁴¹⁶

The authors replied:

The faster-than-light-expansion of space in the young universe does not violate Special Relativity, which only says that *information* cannot be transmitted faster than light.¹⁴¹⁷

This is the kind of double-speak one usually experiences when anomalies of either the Big Bang or Relativity are discovered. Word games are played to deflect attention away from the anomaly. First, the word “information” is hardly mentioned as a constituent part of Einstein’s Relativity theory, let alone as the basis upon which he concluded that the speed of light was constant. Observers receive “information,” but it was Einstein himself who said that the speed of light did not depend on the observer or upon anything else, as long as it traveled *in vacuo*. But according to Peebles, et al., energy and matter can exceed the speed of light, and in essence travel at any speed, just as long as the “information” (whatever that is in distinction to light) travels at 186,000 miles per second. One wonders why the authors did not cite the chapter and verse from Einstein’s canons to substantiate such an innovative claim.

In actuality, all of the above explanations are concocted in order to save the Big Bang theory, since without the proper Omega value

¹⁴¹⁵ P. James E. Peebles, David N. Schramm, Edwin L. Turner and Richard G. Kron, “The Evolution of the Universe,” *Scientific American*, October 1994, p. 53.

¹⁴¹⁶ Letters to the Editors, *Scientific American*, March 1995, p. 10.

¹⁴¹⁷ *Ibid.*,

(which apparently can only be obtained by having the universe expand 269 times faster than the speed of light), the fantasy of modern science cannot find its way to reality. Ironically, the very theory upon which modern cosmology was invented (*viz.*, Relativity), will be forcefully but appropriately modified to save science's more cherished icon, the Big Bang. Even if, for the sake of argument, we were to accept the emphasis on "information" as the criterion to judge the rate of expansion, what is it, precisely, that distinguishes energy's travels from the "information" it sends out? How can energy travel faster than "information," especially since there is no one to witness the first minute of the Big Bang? Unfortunately, this is just another case of modern science trying to fit a square peg into a round hole.

Appendix 2

The Stars and the Speed of Light in Genesis 1

Here we will tackle one of the most common objections raised against a literal reading of Genesis 1. The objection appeals to the apparent anomaly regarding the speed of light and the creation of the stars. It is argued that, since it is established from modern science that the stars are very far away, so far away that light from the nearest star, *Proxima Centauri*, presently takes four years to reach the Earth as it travels 300,000 km/sec, it would have been impossible for the light from stars, which were made on the Fourth day of creation, to reach Earth on that very day, and, in fact, *Proxima Centauri* would not have been seen until at least four years after Adam was created. It could further be argued that if the other stars are hundreds of thousands of light-years from Earth, then the age of the universe could not be anywhere close to the 6000 ~ 13,000 years that a literal reading of the biblical text demands,¹⁴¹⁸ otherwise, we would not be seeing the light from these most distant stars today.

On the surface this seems to be a very logical and worthy objection, and as a result, it has perplexed and paralyzed not a few biblical scholars. Their reactions to this apparent problem are many and varied. Some have been persuaded to abandoned a literal reading of Genesis 1 altogether,¹⁴¹⁹ or at the least, have tried to erect alternative literal renderings. Some have moved to a theistic evolutionary interpretation of Genesis. Others have proposed using the time-warping principles of Special and General Relativity to answer the anomaly;¹⁴²⁰

¹⁴¹⁸ A time span of 6000 years (~ 4000 BC to 2000 AD) is produced from interpreting the ancestral lines of Genesis 5 and 11 as strictly father-son relationships, whereas a time span of 13,000 years (~ 11,000 BC to 2000 AD) would be the largest time-period the Genesis record would allow if, except for Adam-Seth, Seth-Enosh, Lamech-Noah, Noah-Shem, Terah-Abraham, all the other relationships in Genesis 5 and 11 are ancestral and whose principal patriarchs are the heads of the calendar for their particular day. Accordingly, the beginning of creation could also be any date between 11,000 BC and 4000 BC, in round figures. See Volume II of this series for further details.

¹⁴¹⁹ Reverend Stanley L. Jaki, *Genesis 1 Through the Ages*, London, Thomas More Press, 1992.

¹⁴²⁰ In particular, D. Russell Humphreys in the book *Starlight and Time: Solving the Puzzle of Distant Starlight in a Young Universe*, Green Forest, AR, Master Books, 1994. Humphrey's bottom line is that "God used relativity to make a young universe" as he sides with what he calls "the experimentally well-established general theory of relativity." He further suggests, "the universe started as either a black hole or white hole. I suggest here that it was a black hole, and that God let gravity take its course" (pp. 128, 127, 123, quoted in order). In other words, General Relativity's dilation of time through gravity is the basis of Humphrey's theory. Hence, a clock on Earth would

while still others are so bothered by the anomaly that they are willing to rearrange the whole chronology of Genesis 1.¹⁴²¹

At the outset we must note that it makes little difference if one bases his argument on the idea that the stars are billions of light years

measure the Earth's present age as 6000 years, whereas a clock at the edge of the universe would measure 13 billion years. In essence, Humphreys uses the mathematics of General Relativity to posit that the 13 billion years commonly associated with the age of the universe is an illusion created, but allowed, by the principles of General Relativity. However, someone who also employed Relativity's principles came to the exact opposite opinion, which is not surprising, since in Relativity everything is "relative" (G. L. Schroeder, "The Universe – 6 Days and 13 Billion Years Old," *Jerusalem Post*, September 7, 1991). Humphreys can have little argument against this, since according to General Relativity, a person standing at the edge of the universe would think that his immediate vicinity is 6000 years old and the Earth is 13 billion. All in all, this is just another case in which General Relativity becomes the wax nose that can be molded to fit a variety of cosmologies due to the very nature of its inability to have a fixed and absolute reference point.

¹⁴²¹ In particular, Gary Gorman in the book *The Age of the Universe: What are the Biblical Limits?* Washington, Morning Star Publications, 2005, in which he argues that the clause in Gn 1:1, "In the beginning God created the heavens," denotes that at that time the sun and the stars must have been created, and that the text allows for an indefinite time-gap between the appearance of the stars/sun and the creation of the Earth. During this "indefinite time," starlight is said to be traveling to Earth and, based on a speed of 186,000 miles per second, would have had enough time to make the multi-million year journey. To substantiate this interpretation, Gray further argues that the Hebrew עָשָׂה (*asah*) appearing in Genesis 1:16 and normally translated "made" really means "brought forth," such that the light of the sun and stars is now allowed to penetrate to Earth, having previously been obscured by a "cloud of thick darkness" (cf. Jb 38:9) that has since been removed. This is similar to the view we noted earlier propounded by Hugh Ross, yet it must be rejected for the same reasons. There is absolutely no indication in the Genesis text that stars were created before the Earth, and it is likewise exegetically presumptuous to limit the definition of Gn 1:1's "heavens" to the existence of stars in the heavens as opposed to the heavens itself. According to Gn 1:14-16, the sun and stars are placed "in the heavens," that is, they are not *the* heavens but are attached to the heavens. The precise Hebrew phrase is מֵאֲרֶת בְּרָקִיעַ הַשָּׁמַיִם which translates as "lights in the firmament of the heavens," with the preposition "in" denoted by the consonant "ב" prefixing the word for "firmament." This phrase is repeated in Gn 1:17 ("And God set them in the firmament of the heavens") with the addition of the word נָתַן ("set") to reinforce that the sun and stars are distinct from the firmament in which they are set. In addition, there is no "firmament" on the first day of creation, there is only the empty heavens, and as such, the emptiness is waiting to be filled by both the firmament and the celestial bodies, on the second and fourth days, respectively. Moreover, Gray's contention that "brought forth" is a clearer translation than "made" of the Hebrew *asah* is untenable. Although *asah* has some variation in its contextual meaning, when it appears in creation contexts, its meaning is closer to "made" than it is to "brought forth." For example, Psalm 33:6 [32:6] states: "By the word of the Lord the heavens were *made* [*asah*], and by the breath of His mouth all their host." Here *asah* is used in the almost identical wording that appears in Gn 1:1 ("In the beginning God *created* the heavens...") although in that case the Hebrew בָּרָא (*bara*) is used instead of *asah*, which shows that the words are exegetically interchangeable.

just four light years from Earth. In either case, if the speed of light is given an unchanging value of 186,000 miles per second, yet it is agreed that when the stars were created on the Fourth day an observer on Earth would have seen their light immediately, then the light of the stars must have reached Earth either instantaneously or sometime before the close of the Fourth day. Even if we give the light an extra day or two to arrive on Earth such that it would have appeared on the Fifth or Sixth days of creation, this does not provide an adequate solution to the problem, since the nearest star is, at least according to modern astronomy, at least four light years away. As such, the light from *Proxima Centauri* would have arrived four years after Adam was created, and light from the stars that are farther away than 13,000 light years would never have reached the Earth, according to the biblical timetable.

Some might advance the counterargument that, after the stars are mentioned in Genesis 1:16, they are not mentioned again in the biblical text until Genesis 15:5, when God tells Abraham to look up at the stars and count them. This would allow their light to travel for the whole time from the creation week to the time of Abraham's old age. As such, the total time of travel could have been anywhere from two thousand years (4,000 B.C. to 2,000 B.C.) to eleven thousand years (13,000 B.C. to 2,000 B.C.). If we assume light's speed has always been the same, then, at the maximum, the total miles traveled would have been 6.44×10^{16} miles in 11,000 years, or 6.4 quadrillion miles. This distance could accommodate quite a few stars in the universe. In fact, it would more than satisfy the only empirical method of determining the distance to the stars, namely, stellar parallax, which, beyond 100 parsecs or 1.92 quadrillion miles, cannot be applied as an accurate means of measuring distance.

It could further be argued that the alternative and more common method of measuring the distance to the stars beyond the limits of parallax (e.g., the redshift of light) is simply an unproven scientific hypothesis that remains in the throes of controversy, and therefore no biblical scholar is required to accept or apply a redshift/distance relationship as an irrefutable scientific fact. Moreover, various astrophysicists have already proposed a mathematical model for a much shorter travel time for light in the universe. Parry Moon of M.I.T. and Domina Spencer of the University of Connecticut introduced the idea in a paper titled "Binary Stars and the Velocity of Light." The authors state:

The acceptance of Reimannian space allows us to reject Einstein's relativity and to keep all the ordinary ideas of time and all the ideas of Euclidean space out to a distance of a few light years. Astronomical space remains Euclidean for material bodies, but light is considered to travel in Reimannian space. *In this way the time required for light to reach us from the most distant stars is only 15 years.*¹⁴²²

¹⁴²² Parry Moon and Domina Spencer, "Binary Stars and the Velocity of Light," *Journal of the Optical Society of America*, Vol. 43, No. 8, August 1953, p. 635,

The problem with all the above proposals, however, is that they will not allow light from the stars to appear on Earth on precisely the Fourth day of creation, yet the opposite is implied in the text of Genesis, since the stars seem to be included among the devices for the task of time-keeping given to all the celestial bodies (Gn 1:14: “and let them be for signs and for seasons and for days and years”; Gn 1:18: “and to govern the day and the night”). We know the stars’ role in time-keeping today as “sidereal time,” and it is an essential ingredient in chronology for it allows us to have a background in order to measure the sun’s path around the Earth. So precise is this star/sun relationship that the sidereal day is always four minutes shorter in length than that which we keep by the sun on a 24-hour-per-day clock.

Although we are not compelled to include distances beyond 100 parsecs due to the uncertainty of the redshift hypothesis, still, since redshift is considered as a viable measuring device by the modern scientific community, and since, in any case, there certainly could be stars that are further away than the limits our present parallax capabilities can judge them, there needs to be another solution to the starlight problem. In other words, if there is a star beyond 13,000 light years away from Earth, biblical chronology (at least based on an unchanging speed of light) has no way of explaining how that star’s light reached Earth during the Earth’s biblical time of existence.

All is not lost, however, since when we dig deeper into the biblical text there is an easy solution to the problem, and, in fact, there are several solutions, all of which may be working together. First, we must never leave out the possibility that the stars could have been created many thousands of light years from the Earth at the same time that their light was brought to Earth instantaneously by an act of creative fiat. It would certainly be illogical to argue, on the one hand, that God created the stars instantaneously, but then argue, on the other hand, that He could not perform a similar creative miracle that allowed their light to stretch instantaneously to the Earth. If one accepts a divine intrusion for the former, on what basis can he deny it for the latter? God himself determines the boundary line for how and when His miraculous intrusion ceases and natural processes take over. None of us can set arbitrary limits on when the crossover should take place, especially in the very beginnings of creation. One of the main reasons that modern atheistic science believes the universe is 13.5 billion years old is that it denies a creative fiat *at any time*, insisting that everything, from the appearance of matter to starlight, must occur by natural processes. At some point, the

emphasis added. By an exhaustive study of the binaries, Moon and Spencer concluded: “Velocity of light in free space is always c with respect to the source, and has a value for the observer which depends on the relative velocity of source and observer. True Galilean relativity is preserved, as in Newtonian gravitation” (*ibid.*, p. 641).

biblicist has to deny the process of naturalism, whether he decides to do so on the Fourth day of creation or at the so-called Big Bang, for even the most liberal-minded biblical scholar knows that something cannot come from nothing. Hence, it is no great stretch for the conservative biblicist to extend the creative fiat to the speed of light from the stars the same as he does to the stars themselves.

We can also address this issue by pointing out that the cosmological principle has certainly not been proven. The speed assigned to light (300,000 km/sec) has only been demonstrated in our local environment, not throughout the rest of the universe. Although it is reasonable for one to assume that the speed of light is the same everywhere in the universe, by the same token, it would be rather presumptuous to build a whole cosmological system on something that has no solid proof of its reality. At the least, cosmologies that posit a faster speed of light for other parts of the universe which may be under different cosmological constraints should not be dismissed out of hand, especially since there is growing experimental evidence that the speed of light has, on the one hand, been generally slowing down since the inception of the universe in conjunction with the laws of thermodynamics, and, on the other hand, has been increased beyond the value of *c in vacuo* in various laboratory experiments.¹⁴²³

Second, after recognizing that God could have made starlight appear on Earth miraculously, other biblicists may feel compelled to at least offer some naturalistic explanation for the starlight to reach Earth, if not for anything else but to cover all the bases and convince the opponent that there is no escape for those who are looking for a more naturalistic approach to Genesis 1 (e.g., evolutionists). As such, we refer ourselves to the events of the Second day of creation, when God created the firmament. We have already noted that the firmament includes both the expanse of space to the limits of the universe (Gn 1:6-9, 14-19) as well as the space in the immediate vicinity of Earth in which “the birds fly” (Gn 1:20). As we also noted, on the one hand, the Hebrew word *raqia* (firmament) denotes something hard and dense like metal; but on the other hand, it describes something as ethereal and penetrable as air. Fitting the firmament between those two extremes means that we have a truly amazing substance in our possession. Earlier in this volume we belabored the point that the best way to incorporate the two extremes is to understand the firmament as an extremely fine yet dense particulate substance that is frictionless and which permeates every part of the universe and constitutes its vast internal superstructure.

In addition, Scripture speaks of the firmament being transformed from its original dimensions to an “expanded” state. For example, Psalm 104:2 [103:2] says that God is “stretching out heaven like a curtain.”

¹⁴²³ See Appendix 1: “Anomalies Concerning the Speed of Light” in this volume for more information on these laboratory experiments.

Depending on the Hebrew passage cited, the expansion of the firmament is an event that either occurred once in the past; or occurred in the past but was also a progressive event for a certain period of time; or occurred in the past and is still continuing today.¹⁴²⁴

The first question regarding the expansion concerns how fast it occurred. Since the sun and stars were placed “in the firmament of the heavens,” the firmament would need to be big enough at the dawn of the Fourth day to house the sun and all the stars. As the celestial bodies were placed in it, the firmament would have continued to expand away from the Earth, and in the process it would have carried the stars with it to the outer-most recesses of the universe.

If we limit ourselves to the speed of light traveling at 186,000 miles per second at the time the stars are placed in the firmament, and also limit ourselves to affirming that their light reached Earth on the Fourth day, this means that the size of the firmament at the end of its expansion on the Fourth day would be no bigger than the allowable distance light could travel in 24 hours (i.e., the 24 hours from the beginning of the Fourth day to the end of the Fourth day). As such, the radius of the firmament would have been no bigger than 1.6×10^{10} miles, or 16 billion miles; and its volume would have been 1.256×10^{31} cubic miles.

Here is the crucial point: within the distance of 16 billion miles, the light from the stars travels to Earth in a period of 24 hours or less. As such, we have satisfied the objection concerning how starlight could appear on Earth on the Fourth day of creation. Now all we need do is add the subsequent events. As the starlight reaches Earth on the Fourth day, the expansion of the firmament continues. After an initial expansion, the rate of expansion could then have been accelerated in order to arrive at the size the universe is today. In any case, the expansion will eventually cease once the universe reaches its optimal size, but we don't know when that termination point occurred, or if it has yet occurred.

As the firmament continues to expand beyond the radius of the Fourth day it will carry the newly created stars with it. As a result, light

¹⁴²⁴ We posit that, based on the stipulation in Gn 1:8 that “God called the firmament heaven,” the term “heaven” is often interchangeable with “firmament.” In regard to the “expansion,” Jb 9:8 contains the Qal participle הִשְׁתַּדֵּד which can refer to a progressive “stretching out,” and matches the progressive speech in the preceding verse: “the One speaking to the sun, and it does not rise and to the stars he sets a seal.” The same Qal participle appears in Ps 104:2 and Is 42:5 in a similar context of progressive action, whereas Is 44:24 uses the same Qal participle but could refer to a single act or a progressive action. Is 45:12 uses the Qal perfect הִשְׁתַּדַּד referring to a past act, as does Jr 51:15. In Is 51:13 the Qal participle is coupled with a past act (“founded the Earth”), yet Zc 12:1 uses the Qal participle coupled with two other Qal participles (“founding the Earth” and “forms the spirit of man within him,” the latter of which is a continuing action). All in all, the evidence leans towards the “stretching out” as an event with a definitive beginning in the past but in continual progress, at least for some indefinite period of time, and thus a process that did not cease on Day Two of creation week.

from the star will be stretched and, depending on the intensity of the stretch due to whether the star was initially placed nearer to or farther from the Earth, it will produce a corresponding redshift in the wavelength of the starlight. Whether this is the cause of the redshift we see today is not certain, but the major point is made that, within the context of the expanding firmament, the Bible places no limitations on starlight reaching Earth on the Fourth day.

In regard to the redshift, it is interesting to see what happens when we use Big Bang cosmology's accepted formula for measuring the age of distant objects. The age is calculated by the formula $t = t_0 (1 + z)^{-3/2}$, where t_0 is the current age of the universe and z is the redshift factor of the object.¹⁴²⁵ Most of modern science believes the universe began during a Big Bang, and using their own assumptions and scale factors, it believes that this catastrophic event occurred 13.7 billion years ago, at least according to the latest data from NASA's Wilkinson Microwave Anisotropy Probe. Let's say NASA finds a distant object in the sky and assigns it a z -factor of 1. NASA will then plug in the value for t_0 as 13.7 billion years and will compute a value for t , which is understood as the age of the universe when the radiation emission of the distant celestial object took place. In the case where $z = 1$ then $t = 4,844,413,013$ years. Since using the number 13.7 billion years is completely arbitrary (for it is based on the unproven Big Bang assumptions of the universe), let's say we assume t_0 is 10,000 years instead of 13.7 billion. In this case, where $z = 1$ then $t = 3,536$ years. In other words, when an astronomer sees a star with a z -factor of 1, he might just as well assume the universe was 3,536 years old rather than 4.8 billion years old, since the z -factor is only a function of one's assumption regarding the beginning of the universe. If an astronomer finds an even more distant object that correlates to a z factor of 2, then the age of the universe when the object began radiating was 1,924 on the biblical scale but 2.6 billion years on the Big Bang scale.

Of course, the biblicist does not interpret either the 3,536 years or 1,924 years as the different times that two stars were created, for he holds, on a dogmatic basis, that all the stars were created on the same day. It only means that, as the firmament expanded and carried the variously placed stars with it (i.e., some, because of their specific composition and purpose, were placed farther from Earth; while the others were placed nearer, this variation denoted by 1Co 15:41's statement: "for star differs from star in glory"), their wavelength would be stretched by their medium, the firmament, in proportion to the distance they were originally placed from Earth. Thus, if we were to

¹⁴²⁵ This z -factor formula is based on the so-called "dust model" of the universe wherein the major components of the universe do not exert any pressure on their surroundings. But if one were to base the z -factor on the radiation of the CMB in terms of number of particles, the formula would be $t = t_0 (1 + z)^{-2}$. This again, shows the complete arbitrary nature of the formulas since they depend on one's unproven assumptions.

understand redshift as a distance indicator, what we see as differences in redshift values today is merely the result of the differences of the original placement of the stars on the Fourth day of creation. The stars that were placed closer to Earth will now exhibit lower redshift values today, and vice-versa for the stars placed farther away.

Interestingly enough, if we use modern science's formula for measuring the age of the universe when the cosmic microwave background radiation (CMB) was released, we get very close to the time we have predicted that the firmament would create the 2.73° Kelvin temperature. The formula is $T = T_0 (1 + z)$. Plugging in a z -factor of 1089 for the CMB, the Big Bang theory arrives at a universe age of 380,711 years after the primordial explosion for the arrival of the CMB, whereas using the same z -factor the biblicist obtains 0.278 years, which puts the CMB well within the first three months of the first year of creation and after the fall of man when, according to Hildegard's cosmology, the universe began rotating and the firmament needed to be cooled at 2.73° Kelvin.

Appendix 3

The Origin of the Equation $E = mc^2$

Tracing the development of the famous $E = mc^2$ equation will help shed some light on the origin of Einstein's ideas. Contrary to popular opinion, $E = mc^2$ did not originate with Einstein. As van der Kamp reveals:

And then that hackneyed combination of Einstein and the “ $E = mc^2$,” endlessly bandied about in popular-scientific Western folklore! True, it can be deduced from the theory, but it does not prove STR [Special Theory of Relativity], and does not depend on it, as Einstein himself has admitted. That formula has been derived in at least three non-relativistic ways, and abandonment of STR will leave that Bomb-equation unharmed. Even in a vague manner, to think that somehow Hiroshima in a most horrible way has confirmed the theory to be right is unwarranted.¹⁴²⁶

As for the origin of the formula, it wasn't until five years before his death (1955) that Einstein publicly attributed $E = mc^2$ to the 1862 charge-momentum field equations of James Clerk Maxwell.¹⁴²⁷ Previous to Maxwell was the work of J. Soldner who assigned mass to light and thus could calculate its deflection in a gravitational field.¹⁴²⁸ Michael Faraday's 1831 experiments with electricity and induction coils had already introduced the energy/mass relationship, and Maxwell put this in the reciprocal $m = E/c^2$ equation.¹⁴²⁹ In fact, one can go back as far as Isaac Newton in 1704 for the theoretical relationship between mass and

¹⁴²⁶ *De Labore Solis*, p. 51. Van der Kamp cites Carl A. Zappfe's *A Reminder on $E = mc^2$* for the “three non-relativistic ways,” but there are actually a half dozen or more paths to the formula. See text and footnotes.

¹⁴²⁷ Albert Einstein, *Out of My Later Years*, Philosophical Library, New York, viii, 282, 1950. Also Edward Schilpp's, *Albert Einstein, Philosopher Scientist*, Library of Living Philosophers, 1949, p. 62, has Einstein quoted as saying: “The special theory of relativity owes its origin to Maxwell's Equations of the electromagnetic field.”

¹⁴²⁸ J. Soldner, *Berliner Astronomisches Jahrbuch*, 1804, p. 161. Also cited in *Annalen der Physik*, 65:593, 1921.

¹⁴²⁹ The derivation of $E = mc^2$ originates from Maxwell's formula [$f = \delta E / c \delta t$] which equates the force exerted on an absorbing body at the rate energy is received by the body. Since force is also the rate of the change of momentum of the body, which, by the conservation of momentum, is also the rate of change in the momentum of the radiation, the momentum lost by the radiation is equal to $1/c$ times the energy delivered to the body, or $M = E/c$. If the momentum of the radiation of a mass is M times the velocity c of the radiation, the equation $m = E/c^2$ is derived.

energy.¹⁴³⁰ Samuel Tolver Preston used the formula in 1875.¹⁴³¹ Julius Robert Mayer put the formula in terms of ether pressure.¹⁴³²

A curious twist in this saga occurs in 1881 with J. J. Thomson in his work with charged spherical conductors in motion, since he derived a slightly higher coefficient, $E = 4/3mc^2$.¹⁴³³ The same $E = 4/3mc^2$ was found by F. Hasenöhrl in 1904 when he published the first explicit

¹⁴³⁰ In Newton's Query 30 he writes: "Gross bodies and light are convertible into one another..." (*Opticks*, Dover Publications, Inc., New York, p. cxv). Newton's *Opticks* also reveal that he believed gravity would bend light. This is further evidence that many of Einstein's ideas are not original. Stephen Hawking adds that "a Cambridge don, John Michell, wrote a paper in 1783 in the *Philosophical Transactions of the Royal Society of London* in which he pointed out that a star that was sufficiently massive and compact would have such a strong gravitational field that light could not escape...A similar suggestion was made a few years later by the French scientist the Marquis de Laplace..." (*A Brief History of Time*, pp. 81-82).

¹⁴³¹ Preston's purpose in the paper *Physics of the Ether* was to dispel Newton's spiritualistic notion of "action-at-a-distance" and replace it with the mechanical concept of ether. The total force required in Preston's following example is said to be equivalent to $E = mc^2$.

To give an idea, first, of the enormous intensity of the store of energy attainable by means of that extensive state of subdivision of matter which renders a high normal speed practicable, it may be computed that a quantity of matter representing a total mass of only one grain, and possessing the normal velocity of the ether particles (that of a wave of light), encloses a store of energy represented by upwards of one thousand millions of foot-tons, or the mass of one single grain contains an energy not less than that possessed by a mass of forty thousand tons, moving at the speed of a cannon ball (1200 feet per second); or other wise, a quantity of matter representing a mass of one grain endued with the velocity of the ether particles, encloses an amount of energy which, if entirely utilized, would be competent to project a weight of one hundred thousand tons to a height of nearly two miles (1.9 miles)." (S. T. Preston, *Physics of the Ether*, E. & F. N. Spon, London, 1875, #165).

¹⁴³² "If a mass M , originally at rest, while traversing the effective space s , under the influence and in the direction of the pressure p , acquires the velocity c , we have $ps = Mc^2$. Since, however, every production of motion implies the existence of a pressure (or of a pull) and an effective space, and also the exhaustion of one at least of these factors, the effective space, it follows that motion can never come into existence except at the cost of this product, $ps = Mc^2$. And this it is which for shortness I call 'force'" (J. R. Mayer, translated by J. C. Foster, "Remarks on the Mechanical Equivalent of Heat," *The Correlation and Conservation of Forces*, D. Appleton, New York, 1867, pp. 331, 336.)

¹⁴³³ Thomson's use of the formula has not escaped the notice of at least some modern physics textbooks. In *Fundamentals of Physics* by Halliday, et al, they state: "A decade before Einstein published his theory of relativity, J. J. Thomson proposed that the electron might be made up of small parts and that its mass is due to the electrical interaction of the parts. Furthermore, he suggested that the energy equals mc^2 " (John Wiley and Sons, fourth edition, p. 735).

statement that the heat energy of a body increases its “mechanical” mass.¹⁴³⁴ The 1905 Nobel Prize winner Ph. Lenard, a staunch opponent of Einstein, was one of the first to reveal this fact in his 1921 book *Ether and Para-ether*.¹⁴³⁵ In the book, Lenard demonstrated how simple it was to arrive at $E = mc^2$ without any reference to Relativity theory – something Einstein would also admit a few years prior to his death. In his 1929 book *Energy and Gravitation*, Lenard honored Hasenöhr as “the first to demonstrate that energy possesses mass (inertia).”¹⁴³⁶

The history of the $4/3$ coefficient is intriguing. Arthur Miller shows both its origin and how Einstein sought to remove it. Although Einstein purports to have legitimately removed it, Miller shows he did not succeed. Einstein had attributed the excess $1/3$ to mechanical constraints, but Poincaré had demonstrated earlier that it was due to forces that avoid the explosion of the electron.¹⁴³⁷ Engrossed in his General Relativity theory, Einstein did not visit the problem again. Max Von Laue demonstrated that to obtain the final formula $E = mc^2$ “one type of energy...the new physics must eliminate from its list...is kinetic energy.”¹⁴³⁸ The reason is that if mass is based on energy, as $E = mc^2$

¹⁴³⁴ Cunningham, *The Principle of Relativity*, Cambridge University Press, London, 1914, p. 189. N. M. Gwynne, *Einstein and Modern Physics*, p. 36; F. Hasenöhr in *Annalen der Physik*, 4, 16, 589, 1905, and Wien. Sitzungen IIa, 113, 1039, 1904. Hasenöhr’s original equation was $8E/3c^3$, which was then changed to $4E/2c^3$. Some sources have $\frac{3}{4}E=mc^2$; Kostro has $E = \frac{3}{4} mc^2$ (*Einstein and the Ether*, p. 135).

¹⁴³⁵ Ph. Lenard, *Über Äther und Uräther*, Leipzig, Verlag von S. Kitzel, 1921, cited in Kostro’s *Einstein and the Ether*, p. 135.

¹⁴³⁶ Ph. Lenard, *Über Energie und Gravitation*, Berlin/Leipzig, Walter de Gruyter und Co., 1929, cited in Kostro’s *Einstein and the Ether*, p. 136.

¹⁴³⁷ Arthur I. Miller, *The Special Theory of Relativity: Emergence and Early Interpretation*, Springer-Verlag, New York, 1998, pp. 338-339. Miller writes: “But where is the $4/3$ -factor? It is reasonable to conjecture that by May 1907, when Einstein submitted...for publication, he knew full well that the electron’s mass occurred in kinematical quantities deduced from its self-fields as $4/3$ times its electrostatic mass – for example...the role of Poincaré’s stress and very probably of Abraham’s (1905) which contained a detailed discussion of the necessity for an extra energy to correct the Lorentz-electron’s total energy. In fact, Einstein may well have avoided the particular example of Lorentz’s electron because of his having been unable to deduce the $4/3$ -factor from the relativistic kinematics.”

¹⁴³⁸ Max von Laue in *Albert Einstein: Philosopher Scientist*, ed., P. A. Schlipp, Open Court Publishing Co. 1988, p. 529. He continues: “...we must explain why Abraham’s model of the electron as well as cavity radiation yield the different relationship $m = (4/3)(E_0/c^2)$. The reason is the same in both cases. The electromagnetic field is not capable of existing by itself alone, it requires certain supports of a different nature. Cavity radiation can exist only within an envelope, and the charged sphere would fly apart if it were not for certain cohesive forces. In both cases, motion will give rise to an energy current within the material supports which is directed opposite to the motion. It contributes to the total momentum a negative amount and reduces the factor $4/3$ to 1” (*ibid.*, pp. 528-529).

shows, then there cannot be a kinetic energy, $K = \frac{1}{2}mv^2$, which, in turn, depends on the mass. In other words, to obtain $E = mc^2$ one must abandon the most obvious and primary form of energy, kinetic energy.¹⁴³⁹

Prior to this, in 1889 Oliver Heaviside used the $E = mc^2$ principle in his work with capacitors.¹⁴⁴⁰ Henri Poincaré had used the basis for the $E = mc^2$ formula long before Einstein commandeered it for his Special and General Relativity theories.¹⁴⁴¹ In 1903 the Italian scientist Olinto

¹⁴³⁹ This discrepancy can be seen, for example, in the kinetic energy of the electron in the hydrogen atom compared to the speed of light. The ionization energy of the electron is 13.6 eV or 2.17×10^{-18} joules. Transposing $K = \frac{1}{2}mv^2$ to $v = (2K/m)^{1/2}$, and then making the binding energy of the electron equal to the ionization energy, we have $v = (2 \times 2.17 \times 10^{-18} \text{ J} / 9.1 \times 10^{-31} \text{ kg})^{1/2} = 2.18 \times 10^6$ meter/second as the velocity of the electron, but this value is 137.6 times slower than c , the speed of light.

¹⁴⁴⁰ *The Flash of the Cathode Rays: J. J. Thomson and His Contemporaries*, IOP Publishing, Ltd., UK, 1998, by Per F. Dahl: "...not only did Thomson anticipate Einstein's mass-energy equivalence by 24 years...the expression was also anticipated by Oliver Heaviside in 1889." See also David Bodanis' book, *E=mc2: A Biography of the World's Most Famous Equation*. See a critique of Bodanis' book by Hans Melberg, *How Much Gossip is Required Before Science Becomes Interesting*, Walker Publishing, 2000.

¹⁴⁴¹ In his 1900 paper "The Theory of Lorentz and the Principle of Reaction," Poincaré derived the expression $M = S/c^2$, representing M as the momentum of radiation, S as its flux, and c as the velocity of light. Poincaré reasoned that, since electromagnetic energy behaved like a fluid with inertia, if it is discharged from a source there must be a recoil, just as there is a recoil when a ball is shot from a cannon. Using μ for the mass of the recoiling body, and v for its velocity, the equation is $\mu v = S/c^2$. Since $S = Ec$, we have $\mu v = Ec/c^2 = E/c^2$ times c , where the E/c^2 represents the role of mass. When $v = c$, the equation reduces to $E = mc^2$. Poincaré also developed the concepts of relativity and the limit of light's velocity. Einstein makes no reference to Poincaré in his famous 1905 paper, or anyone else. This is all the more significant since Poincaré wrote 30 books and 500 papers, none of which Einstein claimed to have read. Perhaps Poincaré returned the favor to Einstein since, until his death in 1912, he only mentioned Einstein's name in print once, and that was to register an objection (Holton, *Thematic Orgins of Scientific Thought*, p. 249). Regarding the 1905 paper, Clark, an admirer of Einstein, states: "...it was in many ways one of the most remarkable scientific papers that had ever been written. Even in form and style it was unusual, lacking the notes and references which give weight to most serious expositions and merely noting, in its closing paragraph, that the author was indebted for a number of valuable suggestions to his friend and colleague, M. Besso" (*Einstein: The Life and Times*, p. 101). Later, however, Einstein eliminated Besso's name from a paper he submitted to the Berlin Academy in 1915 regarding the perihelion of Mercury, even though the equations were "simply to redo the calculation he had done with Besso in June 1913" (Michel Janssen, "The Einstein-Besso Manuscript," p. 15). As for the 1905 paper, how it is that a 9,000 word paper on one of the most controversial ideas ever presented to mankind made it past the editor of *Annalen der Physik*, the world's leading physics periodical in the world, is anyone's guess. The most likely reason is that Max Planck, the chief editor of *Annalen* in 1905, published it due to his total acceptance of Relativity, which he demonstrated by defending it against Kaufmann in 1906. In any case, an editor of a prestigious physics journal should want to know whether anyone prior to Einstein had

De Pretto had already published $E = mc^2$ two years before Einstein, but Einstein did not mention De Pretto in his 1905 paper on Special Relativity, which is odd considering that he spoke fluent Italian and, by his own admission, read all the Italian physics journals.¹⁴⁴² In 1907, Max Planck, expanding the work of Hasenöhr and using Poincaré's momentum of radiation formula, gave the final derivation of the $E = mc^2$ formula.¹⁴⁴³ All in all, $E = mc^2$ is readily derivable apart from the theory

written about the ideas being presented, especially since the editors themselves were very familiar with the work of Lorentz and Poincaré. When asked about plagiarism, Einstein retorted in his 1907 paper: "It appears to me that it is the nature of the business that what follows has already been partly solved by others. Despite that fact, since the issues of concern are here addressed from a new point of view, I am entitled to leave out a thoroughly pedantic survey of the literature..." (Über die vom Relativitätsprinzip geforderte Trägheit der Energie," *Annalen der Physik* 23 (4), p. 373). Yet in a 1935 paper Einstein admitted: "...because the Lorentz transformation, the real basis of special relativity theory..." ("Elementary Derivation of the Equivalence of Mass and Energy," *Bulletin of the American Mathematical Society* 61:223-230; first delivered as The Eleventh Josiah Willard Gibbs Lecture at a joint meeting of the American Physical Society and Section A of the AAAS, Pittsburgh, December 28, 1934, emphasis Einstein's). There was hardly any way to avoid this realization, since Lorentz's Transformation equation is identical to the equation for Einstein's Special Relativity. My thanks to Richard Moody in *Nexus Magazine*, vol. 11, no. 1, Dec.-Jan. 2004 for many of the above quotes. Against all this is Gerald Holton's view that Einstein never read Lorentz and Poincaré before 1905; that Einstein showed "painful honesty," and that "the so-called revolution which Einstein is commonly said to have introduced into the physics in 1905 turns out to be at bottom an effort to return to a classical purity" (*Thematic Origins of Scientific Thought*, pp. 199, 200, 195 in order of ellipses).

¹⁴⁴² Umberto Bartocci, Professor of Mathematics at the University of Perugia, Italy, in his book, *Albert Einstein E Olinto De Pretto: la vera storia della formula piu' famosa del mondo* (translated: "Albert Einstein and Olinto De Pretto, the true history of the most famous formula in the world," Societa Editrice Andromeda, via S. Allende1, 40139) provides documentation that De Pretto published an article in which he gave, in its final form, the equation $E=mc^2$. This article was published on June 16, 1903, and published again in February 27, 1904, the second time in the *Atti of the Reale Istituto Veneto di Scienze*. De Pretto thereby preceded Einstein's famous 1905 $E=mc^2$ paper by at least a year and half. Could Einstein have copied from De Pretto? No one can prove definitively that Einstein saw De Pretto's article, but Professor Bartocci offers some intriguing speculation. Professor Bartocci traced a link between De Pretto and Einstein, through Einstein's best friend, Michele Besso. As we noted, Besso is the only person credited in the famous $E=mc^2$ paper of 1905. See also R. Carroll's, "Einstein's $E = mc^2$ 'was Italian's idea,'" (*The Guardian*, Nov. 11, 1999, cited in Moody).

¹⁴⁴³ Planck writes: "...through every absorption or emission of heat the inertial mass of a body alters, and the increment of mass is always equal to the quantity of heat...divided by the square of the velocity of light *in vacuo*" (M. Planck, *Sitz. der preuss. Akademie der Wissenschaften* (Berlin), Physik. Math. Klasse. 13 (June, 1907), p. 566. Regarding Einstein's 1905 paper (*Annalen der Physik* 18, 639), Planck shows that, although Einstein came to "essentially the same conclusion by application of the relativity principle to a special radiation process," he did so *by assuming* the existence of one of the mathematical components. Thus Planck continues, "however under the assumption permissible only as a first approximation, that the total energy of a body is

of Relativity, as both Joseph Larmor in 1912; Wolfgang Pauli in 1920, and Ph. Lenard in 1921, demonstrated independently.¹⁴⁴⁴

composed additively of its kinetic energy and its energy referred to a system with which it is at rest” (Cited in *The Einstein Myth and the Ives Papers*, Part II, p. 185).

¹⁴⁴⁴ Larmor in “On the dynamics of radiation,” *Proc. Intern. Congr. Math.*, Cambridge, 1912, p. 213; W. Pauli, Jr., “Relativitätstheorie,” *Encyclopedia Math. Wiss.* V-2, hft 4, 19, 679, 1920, as reported by Herbert Ives in *Journal of the Optical Society of America* 42: 540-543, 1952, and cited in *The Einstein Myth*, pp. 84, 109, 184.

Appendix 4

Do the 1919 Eclipse Photographs prove General Relativity?

As we noted earlier, Einstein desperately needed some physical proof that gravity bent light in the exact proportion his General Relativity theory predicted so that he could give credence to the idea that gravity and acceleration were equivalent phenomenon. In a letter to Ernst Mach he stated that the eclipse results would determine “whether the basic and fundamental assumption of the equivalence of the acceleration of the reference frame and of the gravitational field really holds.”¹⁴⁴⁵ Although a bending of light by gravity would not necessarily prove General Relativity (since non-Relativistic theories could also explain it), it would at least give it enough plausibility to pass the muster of an adoring public. But the physical evidence supporting General Relativity was, shall we say, one of the most biased campaigns of human advertisement the world has ever witnessed. As one author writes: “In 1911 Einstein predicted how much the sun’s gravity would deflect nearby starlight and got it wrong by half.”¹⁴⁴⁶ Another from the same magazine writes:

His second prediction, that light from distant stars would be deflected by the warped space-time around the sun, catapulted him to world fame in 1919, when observations of a solar eclipse seemed to confirm his prediction. But as historians have since shown, the 1919 measurements were equivocal at best.¹⁴⁴⁷

Einstein, however, regarded the solar eclipse results of 1919 as irrefutable evidence for his General Theory of Relativity, for it was

¹⁴⁴⁵ *Thematic Origins of Scientific Thought*, p. 254.

¹⁴⁴⁶ Karen Wright, *Discover* magazine contributing editor, “The Master’s Mistakes,” September 2004, p. 50. This would be no surprise to many today. For example, Paul Marmet in “Relativistic Deflection of Light Near the Sun Using Radio Signals and Visible Light,” writes in his abstract: “...all the experiments claiming the deflection of light and radio waves by the Sun are subjected to very large systematic errors, which render the results highly unreliable and proving nothing” and concluding in his 23-page paper with: “Much of the popularity of Einstein’s general theory of relativity relies on the observations done at Sobral and Principe. We see now that these results were overemphasized and did certainly not consecrate Einstein’s theory. It is interesting to think of what would have happened if the results had been deemed not good enough...” (Physics Dept., University of Ottawa, no date given at www.newtonphysics.com).

¹⁴⁴⁷ Robert Kunzig, *Discover* magazine contributing editor, “Testing the Limits of Einstein’s Theories,” September 2004, p. 54.

reputed to prove that gravity bent starlight by precisely the amount predicted by the theory. In his 1920 book *Relativity: The Special and the General Theory*, he wrote:

The relative discrepancies to be expected between the stellar photographs obtained during the eclipse and the comparison photographs amounted to a few hundredths of a millimetre only. Thus great accuracy was necessary in making the adjustments required for the taking of the photographs, and in their subsequent measurement...The results of the measurements confirmed the theory in a thoroughly satisfactory manner.”¹⁴⁴⁸

Previous to this, in 1913 Einstein employed Erwin Freundlich to detect a bending of starlight near the sun, but his photographs failed to provide any such evidence. After this failure, Einstein confided to Freundlich: “If the speed of light is in the least bit effected by the speed of the light source, then my whole theory of relativity and theory of gravity is false.”¹⁴⁴⁹ Perhaps this is why in March 1914 Einstein seemed a bit more unconcerned in a letter to his best friend, Michael Besso, stating:

Now I am fully satisfied, and I do not doubt any more the correctness of the whole system, may the observation of the eclipse succeed or not. The sense of the thing is too evident.”¹⁴⁵⁰

When asked what he would do if the eclipse results were not in his favor, Einstein retorted with one of his more famous quips: “Then I would have been sorry for the dear Lord – the theory is correct.”¹⁴⁵¹ Unless Einstein was joking, this statement shows he already had set in his mind that Relativity was correct before the 1919 eclipse experiments were performed. Eddington also caught this fever. As Stephen Brush states: “Eddington...was already convinced of the truth of Einstein’s

¹⁴⁴⁸ Albert Einstein, *Relativity: The Special and the General Theory*, translated by Robert W. Lawson, New York: Three Rivers Press, 1961, Appendix III, pp. 146-147.

¹⁴⁴⁹ *Einstein: The Life and Times*, p. 207.

¹⁴⁵⁰ *Thematic Origins of Scientific Thought*, p. 254.

¹⁴⁵¹ In answer to the question of doctoral student Ilse Rosenthal-Schneider, in 1919. Quoted in Rosenthal-Schneider, *Reality and Scientific Truth*, p. 74, as cited in *The Expanded Quotable Einstein*, p. 238. As we noted earlier, Ilse was one of Einstein’s love interests prior to his divorce from Mileva Marić.

theory before making the [eclipse] observations.”¹⁴⁵² Clark reports much the same:

Eddington’s enthusiasm for the General Theory was illustrated when Cottingham asked, in Dyson’s study: “What will it mean if we get double the Einstein deflection?” “Then,” said Dyson, “Eddington will go mad and you will have to come home alone.”¹⁴⁵³

According to C. W. F. Everitt, a detailed reading of the reports on the 1919 eclipse observations

leads only to the conclusion that this was a model of how not to do an experiment...It is impossible to avoid the impression – indeed Eddington virtually says so...that the experimenters approached their work with a determination to prove Einstein right. Only Eddington’s disarming way of spinning a yarn could convince anyone that here was a good check of General Relativity. The results of later eclipse expeditions have been equally disappointing.”¹⁴⁵⁴

Although Einstein and Eddington were so self-assured, many anomalies and suspicions revolve around May 29, 1919’s eclipse photographs. Along with Eddington were three other celebrated British astronomers: Andrew Crommelin, E. T. Cottingham and C. R. Davidson. Eddington and Cottingham did their observations on Principe Island in West Africa, while Crommelin and Davidson did theirs at Sobral, Brazil. Charles Lane Poor offers some sobering comments:

The mathematical formula, by which Einstein calculated his deflection of 1.75 seconds for light rays passing the edge of the sun, is a well known and simple formula of physical optics. Not a single one of the concepts of varying time, or warped or twisted space, of simultaneity, or of the relativity of motion is in any way involved in Einstein’s prediction of, or formulas for, the deflection of light. The many and elaborate eclipse expeditions have, therefore, been given a fictitious importance. Their results can neither prove nor disprove relativity

¹⁴⁵² Stephen Brush, *Why Was Relativity Accepted?* p. 201.

¹⁴⁵³ *Einstein: The Life and Times*, p. 285.

¹⁴⁵⁴ C. W. F. Everitt, “Experimental Tests of General Relativity: Past, Present and Future,” in Riazuddin, ed., *Physics and Contemporary Needs*, vol. 4, New York, Plenum, 1980, pp. 529-555. S. Chandrasekhar writes of Eddington: “...had he been left to himself, he would not have planned the expeditions since he was fully convinced of the truth of the general theory of relativity!” (S. Chandrasekhar, *Eddington: The Most Distinguished Astrophysicist of His Time*, Cambridge University Press, 1983, p. 25).

theory...The actual stellar displacements, if real, do not show the slightest resemblance to the predicted Einstein deflections: they do not agree in direction, in size, or the rate of decrease with distance from the sun.”¹⁴⁵⁵

Einstein had referred to 1.7 seconds of arc in his book on Relativity:

...according to the general theory of relativity, a ray of light will experience a curvature of its path when passing through a gravitational field, this curvature being similar to that experienced by the path of a body which is projected through a gravitational field. As a result of this theory, we should expect that a ray of light which is passing close to a heavenly body would be deviated towards the latter. For a ray of light which passes the sun at a distance of Δ sun-radii from its center, the angle of deflection (α) should amount to $1.7''/\Delta$. It may be added that, according to the theory, half of this deflection is produced by the Newtonian field of attraction of the sun, and the other half by the geometrical modification (“curvature”) of space caused by the sun.¹⁴⁵⁶

Although Einstein predicted the deflection of starlight at the surface of the sun should be 1.75 seconds of arc, what the reports do not readily reveal is that evidence from the 1919 expedition showing deflections greater or less than 1.75 seconds were rejected as “spurious.” Even though Einstein insisted “...great accuracy was necessary in making the adjustments required for the taking of the photographs, and in their subsequent measurement,” Poor discovered that Eddington

¹⁴⁵⁵ “The Deflection of Light as Observed at Total Solar Eclipses,” 1930, *Journal of the Optical Society of America* 20:173-211.

¹⁴⁵⁶ Albert Einstein, *Relativity: The Special and the General Theory*, translated by Robert W. Lawson, New York: Three Rivers Press, 1961, Appendix III, p. 145. Johann Georg von Soldner (d. 1833) had already predicted a bending of light around the sun of 0.875 arc seconds, all without the use of Relativity. Einstein doubled Soldner’s figure to 1.75”, claiming that 0.875 was attributable to Newtonian physics, but the remaining 0.875 was attributable only to Relativity’s “space curvature.” Paul Marmet adds: “This amount [1.75”] is twice the one predicted by Einstein in 1908 [A. Einstein, “Jahrbuch der Radioaktivität und Elektronik,” 4, 411, 1908] and in 1911 [A. Einstein, “Über den Einfluss der Schwerkraft auf die Ausbreitung des Lichtes,” *Annalen der Physik*, 35, 898, 1911] using Newton’s gravitational law. In 1911, Einstein wrote: ‘A ray of light going past the Sun would accordingly undergo deflexion to an amount of 4×10^{-6} = 0.83 seconds of arc. Let us note that Einstein did not clearly explain which fundamental principle of physics used in the 1911 paper and giving the erroneous deflection of 0.83 seconds of arc was wrong, so that he had to change his mind and predict a deflection twice as large in 1916” (“Relativistic Deflection of Light Near the Sun Using Radio Signals and Visible Light,” Physics Dept. University of Ottawa, www.newtonphysics, p. 15).

discarded 85% of the data from the eclipse photographs taken at Sobral, Brazil, due to “accidental error.” The truth is that the displacements of the stars were in every conceivable direction, some in the exact opposite position predicted by Relativity. At a meeting of the Royal Astronomical Society in 1919, Ludwik Silberstein revealed that the displacements were not radial as Einstein’s theory claims, often deflecting from the radial direction by as much as 35°, leading Silberstein to conclude: “If we had not the prejudice of Einstein’s theory we should not say that the figures strongly indicated a radial law of displacement.”¹⁴⁵⁷ In fact, only 15% of the displacements were consistent with Einstein’s prediction. After providing the reader with Table III from the official Report of the expeditions,¹⁴⁵⁸ Poor reveals the numerous discrepancies:

This table shows that, on the average, the observed deflection, as given by the British astronomers, differs by 19% from the calculated Einstein value [1.75”]. In the cases of two stars, the agreement between theory and observation is very nearly perfect, the observed value being only 3% in error: in other cases, however, the differences range from 11% to 60% [and] the rate of decrease from star to star is radically different from that predicted. The difference between the deflection of the star nearest the sun and that of the farthest star should be, according to Einstein, 0.56”; while the observed or measured difference was 0.82”, practically 50% out of the way. *The diagrams...show clearly that the observed displacements of the stars do not agree in direction with the predicted Einstein effect.* This point was nowhere [sic] mentioned in the Report, which took up only the amount of the radial component of the actual displacement. But, after the measurements of the plates became available for study, several investigators called attention to this fact of a radial disagreement in direction between the observed and predicted displacements...in the case

¹⁴⁵⁷ Royal Astronomical Society, December 12, 1919, as cited in *The Observatory*, 43, 548, pp. 33-45, January 1920.

¹⁴⁵⁸ Under the title: “Radial Displacement of Individual Stars,” the following information was given in the “Report” authored by Dyson, Eddington and Davidson and presented to the Royal Astronomical Society:

Star	Calculation	Observation
11	0.32"	0.20"
10	0.32"	0.32"
6	0.40"	0.56"
5	0.53"	0.54"
4	0.75"	0.84"
2	0.85"	0.97"
3	0.88"	1.02"

of the star furthest from the sun to 37° . Thus, even the seven best plates out of thirty-three, which showed star images, give inconsistent results: the observed shifts in the star images, if real, *do not coincide with the Einstein effect either in amount or direction.*¹⁴⁵⁹

It has been claimed by many that the differences between the observed and predicted shifts are no greater than should be expected...Now this very question was investigated by Dr. Henry Norris Russell, of Princeton University, a most ardent upholder of relativity theory. He studied these star displacements with a view of determining whether the departures from Einstein's predicted effects are real or not, and, if real, of finding some possible explanation for them. As a result of an exhaustive examination of them, he concludes that these differences between the observed and predicted displacements, these non-Einstein displacements, as he calls them, are *real*, and cannot be attributed to mere accidental errors of observation and measurement...Dr. Russell assumes that the most probable source of these proved non-Einstein deflections is to be found in instrumental errors: in an alteration in the shape of the mirror, caused by the heat of the sun...But one point is perfectly clear. If it be admitted that the heat of the sun so distorted the mirror of the apparatus as to cause errors of 20%, in some cases of 50%, of the measured displacement, then the entire set of plates is worthless for proving the existence or non-existence of the "Einstein effect."¹⁴⁶⁰

After providing the reader with the results of the photographic plates at both Sobral and Principe,¹⁴⁶¹ Poor offers the following analysis:

These results, in each case, are the means [average] of the radial components only; nothing whatever being given as to the directions in which the actual displacements took place. The Einstein theory requires a deflection, not only of a certain definite amount, but also in a certain observed direction. To discuss the amount of the observed deflection is to discuss only one-half of the whole question, and the less important half at that. The observed deflection might agree exactly with the predicted amount; but, if it were in the wrong direction, it

¹⁴⁵⁹ *Gravitation versus Relativity*, pp. 218-219, emphasis added.

¹⁴⁶⁰ *Ibid.*, pp. 220-222, emphasis added.

¹⁴⁶¹ (1) Sobral, 4-inch camera, 7 plates = 1.98" with probable error of about ± 0.12 "; (2) Principe, 13-inch astrographic lens, 2 plates = 1.61" with probable error of about ± 0.30 "; (3) Sobral, 13-inch astrographic lens, 16 plates = 0.93" with the Report stating: "For reasons already described at length not much weight is attached to this determination."

would disprove, not prove, the relativity theory....Now, the diagrams...of the seven best plates, the seven taken at Sobral with the 4-inch camera, *show clearly and definitely that the observed deflections are not in the directions required by the Einstein theory*...not only that, but every one of the seven plates shows the star deflected in the same direction from that called for by the relativity theory. Similarly for star No. 11, every dot again lies on the same side of the Einstein arrow, and the mean deflection differs by 37° from the predicted. In this case two of the individual plates give deflections practically in the reverse direction to that called for by the theory. The best agreement between theory and observation is given by star No. 4, where the mean difference amounts to about a single degree: but, even in this case, the individual results differ by as much as 30° . The relativist either totally disregards these discordances in the directions of the observed deflections, or invokes the heating effect of the sun to distort the mirror by just the proper amount to explain them away!¹⁴⁶²

Again, disregarding directions entirely, and taking into account only the size of the deflection, it is noted that the disagreement between the three mean results, as given in the Report, is over 100%; the largest value being well over twice that of the smallest. The actual amount of the deflection as obtained with the astrographic lens is 58% of that obtained at Principe and only 47% of that of the 4-inch camera at Sobral. This difference in results is far beyond the limits of accidental errors.¹⁴⁶³

When the deflections of light, as actually observed, are considered both in direction and in amount, the discordances with the predicted Einstein effect become marked, and the plates present little or no evidence to support the relativity theory. Further, if these deflections are real, and not due to instrumental errors (so readily called upon by the relativist to explain everything that the relativity theory cannot account for) then it has not yet been shown that the relativity theory is the only possible explanation. As a matter of fact there are other perfectly possible explanations of a deflection of a ray of light; explanations based on every-day, common-place grounds. Abnormal refraction in the Earth's atmosphere is one; refraction in the solar envelope is another. The atmospheric conditions under which the eclipse plates were taken were necessarily abnormal; and the plates, themselves, clearly show that the rays of light passed through a mass of matter in the vicinity of the sun; a mass of density sufficient to clearly imprint its picture upon the photographic plates. Such is the

¹⁴⁶² *Gravitation versus Relativity*, pp. 223-225, emphasis added.

¹⁴⁶³ *Gravitation versus Relativity*, p. 225.

evidence, and are the observations, which, according to Einstein, “confirm the theory in a thoroughly satisfactory manner.”¹⁴⁶⁴

In his 1970 book, Leon Brillouin made a similar critique:

These were very inaccurate experiments with individual errors of 100% and averaged errors of 30%. The theory is not safe because it assumes an ideal vacuum near the sun’s surface, while we can observe very powerful explosions of matter and radiations from the sun.¹⁴⁶⁵

Einstein predicts the deflection of a light ray passing near the surface of the sun, but we obtain a similar result if we consider a light ray as a beam of photons $h\nu$ with masses $h\nu/c^2$. Only the numerical coefficient is different, and Einstein’s prediction is twice as large as that in the computation with photons. Here the experimental results are actually very poor with errors of 100% magnitude...looking candidly at these observations, one feels that very large sources of error are obviously playing a substantial role, and our present knowledge of the turbulent flow in the solar atmosphere yields the most probable explanation. The Shapiro experiment is certainly safer than the deflection of light rays.¹⁴⁶⁶

Poor’s explanation is even more detailed, showing from the science of optics what is a perfectly logical explanation to the many and varied deflections obtained in Eddington’s series of photographs:

The Sobral photographs show clearly that the rays of light, in their course from the distant stars, passed through masses of matter near the sun. This matter was sufficiently dense and reflected enough sunlight to imprint its image upon the photographic plates, and there can be no question as to its existence and its presence in the paths of the light rays. Further, whenever a ray of light passes from free space into, or through a medium of any kind of density, such ray is refracted, or bent out of its straight course. The path of such a ray becomes curved, and the amount of refraction, or curvature, depends on the density of the medium into which the ray passes and the angle at which it meets the surface. This is the fundamental law of physics: upon the refractive effects of different media are based our optical instruments and experiments: eye-glasses,

¹⁴⁶⁴ *Gravitation versus Relativity*, p. 226.

¹⁴⁶⁵ Leon Brillouin, *Relativity Reexamined*, New York, Academic Press, 1970, p. 54.

¹⁴⁶⁶ Leon Brillouin, *Relativity Reexamined*, New York, Academic Press, 1970, p. 98.

cameras, microscopes, telescopes; all depend upon the refractive effect of glass upon the ray of light. It is certain, therefore, that the rays of light, in passing through the solar envelope, suffered a refraction, or bending, of some kind and amount. This fact is as well established as the sun itself. The sole question is whether this refraction was sufficient in amount and in direction to account for the observed displacements of the star images. This possibility of accounting, in a perfectly normal way, for the observed light deflections has been dismissed by the relativist in a few words as a matter scarcely worth mentioning.¹⁴⁶⁷

While it is certain that the rays suffer some refraction in passing through the solar envelope, it is claimed by most astrophysicists that the effect is so small as to be negligible in comparison with the observed deflections. This idea is so firmly fixed that the possibility of explaining any portion of the deflections by refraction was dismissed by the British astronomers in their Report with a scant phrase or two. The entire question depends upon the possibility of the solar envelope having density large enough to bend a ray of light by the required amount, and this in turn upon what that density really is. It can readily be shown by the ordinary formulas of optics that a lens of matter of a density of about 1/140th that of air at standard pressure and temperature would deflect a ray of light by about 1", the amount observed in the case of the star nearest the sun.¹⁴⁶⁸

While, thus, there is a very open question as to the amount of refraction which would be caused by a medium of varying density, there is on the other hand practically no question as to the direction in which the bending will take place. This is purely a matter of geometry, and depends upon the fundamental law, that the incident ray, the normal to the surface, and the refracted ray, all lie in the same plane....In the case of the photographs taken at Sobral during the eclipse of May 29, 1919...an approximate solution can be made with great simplicity. For, assuming the solar envelope to be an ellipsoid of revolution with its axis coinciding with that of the sun, the axis of figure would be practically at right angles to the line of sight.¹⁴⁶⁹

¹⁴⁶⁷ *Gravitation versus Relativity*, p. 240.

¹⁴⁶⁸ *Ibid.*, pp. 240-241.

¹⁴⁶⁹ *Ibid.*, pp. 247-248. Poor then adds three tables which show the contrasting results between Einstein's relativity and Poor's refractive index of the solar envelope and residual matter. Regarding Table IV of the perihelia of Mercury, Venus, Earth and Mars, using the sum of squares to gauge the accuracy of the results, Einstein's theory comes in at a whopping 473 off the observed values, while Poor's is only 14 (*ibid.*, p. 234). Regarding Table VI of the stars' Computed Departures from Radiality, Einstein's

In light of Poor's devastating analysis, Sir John Maddox, editor of *Nature*, wrote: "They [Crommelin and Eddington] were bent on measuring the deflection of light....What is not so well documented is that the measurements in 1919 were not particularly accurate."¹⁴⁷⁰ G. Burniston Brown adds:

Initially stars did appear to bend as they should, as required by Einstein, but then the unexpected happened: several stars were then observed to bend in a direction transverse to the expected direction and still others to bend in a direction opposite to that predicted by relativity."¹⁴⁷¹

Scientific American, obtaining their report directly from Crommelin's own words, shows that even the photograph used for the tally had a significant margin of error:

The resulting shift at the limb is 1.98", with a probable error of 0.12". It will be seen that this result agrees very closely with Einstein's predicted value of 1.75".¹⁴⁷²

Eddington's experience at Principe Island, West Africa was tenuous at best. On the day of the eclipse, May 29, 1919, the team was greeted with heavy rain. According to Clark, events occurred with a lick and a promise:

Not until 1:30 P.M., when the eclipse had already begun, did the party get its first glimpse of the sun. "We had to carry out our programme of photographs on faith," wrote Eddington in his diary. "I did not see the eclipse, being too busy changing

theory deviates by 2,489 from observed values, while Poor's only by 410 (*ibid.*, p. 251). In regard to Longitude of Node and Inclination, Poor's results come within 84% and 80%, respectively, when compared to Newcomb's observational figures published in 1895 (*ibid.*, p. 253). As N. Martin Gwynne notes: "The reader will doubtless not be surprised to learn that the predictions resulting from Poor's formula were many, many times more accurate than those produced by Relativity Theory. Moreover the same explanation (the assumption of the self-same solar atmosphere), enabled him also to predict correctly the perihelion of Mercury and without, incidentally, being thrown into confusion by the perihelia of the other planets. The same assumption, in other words, gave as satisfactory an answer as could be desired in two radically different investigations" (private paper).

¹⁴⁷⁰ "More Precise Solar-limb Light Bending," *Nature* 377:11, 1995.

¹⁴⁷¹ "What is Wrong with Relativity," *Bulletin of the Institute of Physics and Physical Society*, 1967, pp. 71-77.

¹⁴⁷² *Scientific American Supplement*, December 6, 1919, as cited in *Scientific American*, September 2004, p. 104.

plates, except for one glance to make sure it had begun and another halfway through to see how much cloud there was. We took sixteen photographs. They are all good of the sun, showing a very remarkable prominence; but the cloud has interfered with the star images. The last six photographs show a few images which I hope will give us what we need...¹⁴⁷³

One might think that the mission would have been aborted, considering the minimal number of samples Eddington managed to put together. Of the six salvageable photographs, Eddington admits, seemingly without the slightest shame, that he based his conclusion on only *one photographic plate*, while he rejected the other photographs that did not give the results he expected. As he records it: “But one plate that I measured gave a result agreeing with Einstein,” from which he then exclaims, “it was the greatest moment of [my] life.”¹⁴⁷⁴ But even Relativists admit: “...it is absolutely crucial to obtain as many photographs with as many star images as possible. To this end, of course, it helps to have a clear sky.”¹⁴⁷⁵ When compared to a 1973 expedition that “hoped to gather over 1,000 star images,”¹⁴⁷⁶ this makes Eddington’s adventure into a virtual sham. Incidentally, the results of the 1973 eclipse resulted in 0.95 ± 0.11 arc seconds, a figure right in line with the Newtonian prediction, and not even close to Einstein’s. Not surprisingly, the 1973 expedition was called the “swan song for this type of measurement.”¹⁴⁷⁷ That the public could be bamboozled into believing that Relativity was proven by one mere photograph in the midst of five others that nullified the theory shows the influence Eddington carried in that day, as well as the utter mystique of the Relativity theory.

¹⁴⁷³ Einstein: *The Life and Times*, p. 285.

¹⁴⁷⁴ Einstein: *Life and Times*, pp. 285-286. The photographic plate considered as successful measured a displacement of $1.61'' \pm 0.30''$. So even in the plate he depended on to “prove” Relativity, it is only the margin of error (0.30") Eddington granted to himself for the final calculations that brought the result within respectable range of Einstein’s 1.75" prediction. If Eddington had taken the minus side of the margin of error, the result would have been a dismal 1.31" and no confirmation of Relativity could be extracted from it. In any case, the other five plates that Eddington discarded measured 0.93" or less. In proper scientific procedure, it is the five measuring 0.93" or less which would serve as the control and the 1.61" as the anomaly, but Eddington conveniently reversed that protocol. It just so happens that a deflection of 0.93" is almost identical to the prediction of Newtonian physics and astronomically far from Einsteinian physics.

¹⁴⁷⁵ Clifford M. Will, *Was Einstein Right? Putting Relativity to the Test*, New York: Basic Books, Inc., Publishers, 1986, p. 77.

¹⁴⁷⁶ *Was Einstein Right?* p. 80.

¹⁴⁷⁷ Clifford Will, *Was Einstein Right?* p. 80.

The questionable tactics that occurred in the 1919 eclipse expeditions also occurred in 1922 efforts in Australia. After putting the evidence of their photographs on a graph, the results show 44 data points below the curve and only 25 points above, which means that whoever created the graph did not choose the proper median curve, apparently in order to give the impression that the results conformed with Relativity theory. As Arthur Lynch writes:

The results of the observations are shown on a chart, by a series of dots, and by tracing connections between these dots it is possible to obtain a “curve” from which the law of deviation is inferred. But the actual charts show only an irregular group of dots, through which, if it be possible to draw a curve that seems to confirm the theory of Relativity, it is equally possible to draw a curve which runs counter to the theory. Neither curve has any justification.¹⁴⁷⁸

Sir Edmund Whittaker, who wrote one of the more popular yet comprehensive volumes on the history of physics, and who was no enemy of Relativity, nevertheless stated in 1952:

While it must not be regarded as impossible that the consequences of Einstein’s theory may ultimately be reconciled with the results of observations, it must be said that at the present time there is a discordance.¹⁴⁷⁹

Despite these discrepancies, American astronomer W. W. Campbell made an announcement in 1923 that Einstein’s predictions had been confirmed by the 1922 results.

In 1976, B. E. Jones performed tests which determined that light passing near the sun results in only about .95 second of arc, a result almost half that predicted by relativity theory, and thus confirming the Newtonian basis, not Relativity’s.¹⁴⁸⁰ Astronomer [Robert Dicke](#) (who, *contra* Relativity, revealed that Mercury’s perihelion was due in part to the sun’s oblateness), writes:

Owing to the short duration of the eclipse and the consequent absence of repetitions of the observation, there has always been considerable doubt about the freedom of the final results from systematic errors. Furthermore, the results derived from past solar eclipses...have scattered a great deal. The accuracy of the

¹⁴⁷⁸ Arthur Lynch, *The Case Against Einstein*, p. 264.

¹⁴⁷⁹ Edmund T. Whittaker, *A History of Ether and Electricity*, vol. 2, p. 180.

¹⁴⁸⁰ *Astronomical Journal*, 1976, 81:455.

gravitational deflection of light determined from total eclipses is probably no better than 20 per cent.”¹⁴⁸¹

Dicke’s chart shows six eclipse tests between 1919 and 1952, each with several results. Beginning with the 1919 eclipse, the results are as follows in seconds of arc:

- Trial 1: 1.87-2.12
- Trial 2: 2.00-2.25
- Trial 3: 2.05-2.30
- Trial 4: 1.87-2.05
- Trial 5: 1.27-1.87

Only Trial 5 comes within range of Einstein’s 1.75 prediction, and that is only because 1.75 comes between the lower and upper limit of the actual deflections. As Guggenheimer stated in 1925:

An examination of the various tables of the deflections observed shows that many of them are far away from the quantities predicted. The quantity approximating the predicted one [1.75 sec.] is obtained by averaging a selected few of the observations.

The 1922 eclipse (Australia):

- Trial 1: 1.37-2.17¹⁴⁸²
- Trial 2: 1.62-1.80
- Trial 3: 1.15-2.37
- Trial 4: 1.95-2.35
- Trial 5: 1.62-2.05

¹⁴⁸¹ “Solar Oblateness and Gravitation,” *Gravitation and the Universe*, p. 27. In addition to Eddington’s poor photography, his calculation of the deflections is contingent upon determining the star’s distance from the limb of the sun. For example, a star which is close to the limb will be deflected about 1.75", but a star twice the distance from the limb will be deflected half as much. Hence, determining how close a star is to the limb of the sun is absolutely crucial. Suffice it to say, Eddington did not have nearly enough evidence to begin a calculation as sensitive as this one.

¹⁴⁸² It is interesting to note that supporters of General Relativity will record the results of these eclipse photographs in such a way as to make them appear to be very close to Einstein’s prediction of 1.75". For example, in Trial 1 from Australia, the data shows a range from 1.37" to 2.17", which means that there were many data points, some above and some below the median line. But when the same event is recorded in Relativity textbooks the figure given is 1.77" \pm 0.40", since 1.77 is between 1.37 and 2.17. In other words, there may have been no results showing a 1.77" deflection, but the author merely took the average of the high (2.17") and low (1.37") data and recorded it as 1.77", since that figure is close to Einstein’s prediction of 1.75". In addition, the reader is expected to assume that the \pm 0.40" margin of error has no effect on what the conclusion should be.

The 1929 eclipse (Sumatra):

- Trial 1: 1.62-1.87 and 2.12-2.37
- Trial 2: 1.80-2.20
- Trial 3: 1.85-2.05

The 1936 eclipse (One in USSR and two in Japan):

- Trial 1: 2.40-2.95
- Trial 2: 2.30-3.10
- Trial 3: 1.25-2.30

The 1947 eclipse (Brazil):

- Trial 1: 1.70-2.25
- Trial 2: 1.85-2.60

The 1952 eclipse (Sudan):

- Trial 1: 1.60-1.80
- Trial 2: 1.20-1.50

As noted, the eclipse test in 1973 showed the same widely scattered results, even though they produced 150 good pictures from which to determine the results.¹⁴⁸³ In 1976, B. E. Jones performed tests which determined that light passing near the sun results in only about 0.95 seconds of arc, a result, once again, that is almost half that predicted by Relativity theory.¹⁴⁸⁴

In 1960, H. Von Klüber had already outlined why such tests were futile for Relativity. Among the difficulties are the refraction of light in the sun's corona; distortions in the optics caused by temperature changes during the eclipse; changes in scale between the eclipse and the control photographs; distortions in photographic emulsion while drying; and errors in measuring the images on the photographs.¹⁴⁸⁵ In 1995 Alan MacRobert, senior editor of *Sky and Telescope*, notes:

Rare is the night (at most sites) when any telescope, no matter how large its aperture or perfect its optics, can resolve details

¹⁴⁸³ J. B. Zirker, *Total Eclipses of the Sun*, Princeton University Press, 1995, fig. 9.4, p. 179. The results were $0.95'' \pm 0.11''$.

¹⁴⁸⁴ *Astronomical Journal*, 1976, 81:455.

¹⁴⁸⁵ "The Determination of Einstein's Light-Deflection in the Gravitational Field of the Sun," *Vistas in Astronomy*, Pergamon Press, London, 3:41-77, 1960.

finer than 1 second of arc. More typical at ordinary locations is 2 or 3 arc-second seeing, or worse.¹⁴⁸⁶

Undaunted, the Relativists were still determined to “prove” Relativity. While the eclipse experiments were fading, Relativists then began a series of experiments using light from quasars and radio waves near the sun. But again, “the primary factor limiting the accuracy was the solar corona, the hot, turbulent gas of ionized hydrogen at 2 million degrees that extends out to several solar radii from the sun.”¹⁴⁸⁷ Regarding the sun’s corona, other physicists address the additional claim by Relativists concerning the Viking space probe. They reveal the internal contradictions of General Relativity to explain the results:

...all the experiments claiming the deflection of light and radio waves by the sun are subjected to very large systematic errors, which render the results highly unreliable and apparently incorrect....There is a desperate situation among scientists for not being able to show, with the most sophisticated technology, what is considered to be the basic principle of general relativity on which rely most of modern science, while this was claimed to be demonstrated by Eddington in 1919 using a simple four inch amateur size telescope.”¹⁴⁸⁸

¹⁴⁸⁶ “Beating the Seeing,” *Sky and Telescope*, 89, 4, pp. 40-43, 1995.

¹⁴⁸⁷ *Was Einstein Right?* p. 85.

¹⁴⁸⁸ Paul Marmet and Christine Couture, “Relativistic Deflections of Light Near the Sun Using Radio Signals and Visible Light,” <http://itis.volta.alessandria.it/episteme/marm1.html>.

Appendix 5

Does Mercury's Residual Perihelion Prove General Relativity

Einstein also claimed that his prediction of the perihelion of Mercury supported his theory of General Relativity, but this assertion is denied by the same inaccuracies and biases appearing in the eclipse photographs. By all accounts, determining the complete reasons for the perihelion of Mercury is a formidable task. Based on the gravitational contributions of each of the planets (Pluto excluded), most of Mercury's perihelion is accounted for by Newtonian physics, but a residual remains (about 10% or less).¹⁴⁸⁹ Newtonian physicists tried many and various means to find the reason for the residual, hypothesizing such things as interplanetary movements; the existence of another planet (Vulcan); reworking the inverse square law to 2.0000001574 instead of 2.0, but only with marginal success. Still today, due mainly to unknown variables in the data, as well as the arbitrary means of interpreting the data, Mercury's residual perihelion remains perplexing. There is at least a four-body calculation (the sun, Venus, Earth, Jupiter) if not a ten-body calculation (the sun, Earth and the eight planets) involved. In Newtonian physics, calculation of gravitational attraction between two bodies is relatively simple, but when three or more bodies are in the mix Newton's formula is virtually useless. As Poor states: "Under certain special conditions, mathematicians have been able to find an approximate solution of the problem, but even such approximate solution is extremely intricate. No solution of the general problem has been found."¹⁴⁹⁰

The first to attempt to measure Mercury's perihelion was made in 1843 and then again in 1859 by the French mathematician Urbain Leverrier. He began by analyzing records of sixteen of Mercury's transits across the sun dating from 1677 to 1848. Calculating the entry and exit times of Mercury's transit allows a determination of the planet's angular position within one arc second. After taking account of the gravitational attraction of Venus, Earth, and Jupiter, Leverrier had a residual figure of 38" (arc seconds) per century, but he could not account for the discrepancy only by the perihelion, and thus he began to examine Mercury's eccentricity. He then included 400 meridian transits of

¹⁴⁸⁹ Earth and each of the planets cause gravitational perturbations on each other. Additionally, the sun's oblateness will also add to the general perturbation. The contributions to the perturbations on Mercury, amount to the following (as measured in arc seconds per century): Venus: 277.856; Earth: 90.038; Mars: 2.536; Jupiter: 153.584; Saturn: 7.302; Uranus: 0.141; Neptune: 0.042; Sun's oblateness: 0.010 (as measured prior to the 1960s). These figures add up to 531.509 as the total perturbation on Mercury. But since Mercury's precession is 574.10 arc seconds, this leaves 42.591 arc seconds unaccounted for. NB: the perturbations in the geocentric system (whether Ptolemaic or Tychoic) would be precisely the same.

¹⁴⁹⁰ *Gravitation versus Relativity*, p. 123.

Mercury between 1801 and 1842, which he obtained from the Paris Observatory, and upon finding an eccentricity of 22" he then added the two figures (38" + 22") and concluded that the amount of precession was 60" per century. After preparing his final tables, however, he arbitrarily eliminated the 22" of eccentricity, leaving 38" as the final sum.¹⁴⁹¹

In 1895, Simon Newcomb was the next scientist to attempt to find the reason for Mercury's residual perihelion. Working with Leverrier's 38" figure, Newcomb arbitrarily decided to reduce the eccentricity, which in turn increased the rotation, and he obtained residual figures of between 41" and 43". Hence, the 43" remained in the textbooks (at least up until Einstein), as the residual perihelion of Mercury not accounted for by Newtonian physics.¹⁴⁹² At that time, however, Newcomb suggested that the sun's oblateness might provide the solution to the remaining puzzle. This would be a significant hypothesis, since both Newtonian and Relativistic calculations of perihelion assume a spherically symmetrical sun.

In Einstein's attempt to account for the residual perihelion there has been some suspicion that, knowing the accepted value in advance (43 arc seconds), he juggled his figures to meet those expectations. That Einstein was already aware of the needed figure was made plain in his book on Relativity:

In point of fact, astronomers have found that the theory of Newton does not suffice to calculate the observed motion of Mercury with an exactness corresponding to that of the delicacy of observation attainable at the present time. After taking account of all the disturbing influences exerted on Mercury by the remaining planets, it was found (Leverrier: 1859; and Newcomb: 1895) that an unexplained perihelical movement of the orbit of Mercury remained over, the amount of which does not differ sensibly from the above mentioned +43 seconds of arc per century. The uncertainty of the empirical result amounts to only a few seconds.¹⁴⁹³

¹⁴⁹¹ N. T. Roseveare, *Mercury's Perihelion from Le Verrier to Einstein*, Oxford University Press, 1983; L. V. Morrison, C. G. Ward, "An analysis of the transits of Mercury: 1677-1973," *Notes of the Royal Astronomical Society* 173, 183-206, 1975.

¹⁴⁹² S. Newcomb, "Tables of Mercury," *Astronomical Papers of American Ephemeris Nautical Almanach*, 6, Washington, 1895-1898. The advance of Mercury's perihelion was calculated by Newtonian physics to be 531.509 arc seconds per century. This falls about 43 seconds short of the observed value, which is 574 arc seconds. As it is commonly understood, the total apparent precession of Mercury's perihelion (as observed from the Earth) is 5600"/100years. Of this, 5025" is attributed to the Earth's precession (precession of equinoxes) and 531.509" due to planetary perturbations of Mercury's orbit. This leaves 43"/100 years unexplained.

¹⁴⁹³ Albert Einstein, *Relativity: The Special and General Theory*, Appendix III.

The original Einstein-Grossmann theory accounted for only 18" of the residual 43" of Mercury's perihelion, which is documented in the original Einstein-Besso manuscripts made public in 1914 by Dutch physicist Johannes Droste. Einstein subsequently retracted the paper, changed his Relativistic field equations no less than three times, and resubmitted them three times, respectively, to the Berlin Academy before the final result of 43" was achieved.¹⁴⁹⁴ Still, Charles Lane Poor adds that in arriving at the 43" Einstein did not use the unit of time required by Relativity theory; rather, he used the commonly accepted Newtonian unit of time. Poor also adds that Einstein insisted "in clear unequivocal language" in the Preface of the book that, of all the planets, only Mercury presented anomalous data.¹⁴⁹⁵ Yet Newcomb's 1894-1895 data of 60,000 observations records discordances in the motions of other planets, totaling eleven in all, and four of which he considers highly significant. Thus Poor concludes: "Can it be possible that he [Einstein] has never read the very papers upon which the astronomical proof of the Relativity Theory is supposed to be based?"¹⁴⁹⁶

Physicist Tom Van Flandern studied Einstein's calculations and found there were "three separate contributions to the perihelion; two of which add, and one of which cancels part of the other two; and you wind up with the right multiplier." The same article reports that Van Flandern approached a University of Maryland colleague who had known Einstein in their respective work at Princeton's Institute for Advanced Study regarding how, in his opinion, Einstein had arrived at the accepted figure of 43 arc seconds. The colleague replied that it was his impression that "knowing the answer, he jiggered the arguments until they came out with the right value."¹⁴⁹⁷ Poor says much the same, but points out an added twist in Einstein's deception:

Yet this coincidence of figures is largely due to the astuteness of Einstein in quoting the result of Newcomb's preliminary investigation, and in ignoring the classic work of Leverrier and the final results of Newcomb. According to Einstein the results

¹⁴⁹⁴ Michel Janssen, "The Einstein-Besso Manuscript: A Glimpse Behind the Curtain of the Wizard," Fall 2002, p. 12-15, and "What Did Einstein Know and When Did He Know It? A Besso Memo Dated August 1913."

¹⁴⁹⁵ Einstein writes in the Preface: "The sole exception is Mercury, the planet which lies nearest the sun. That for all the planets, with the exception of Mercury, this rotation is too small to be detected..." In a July 30, 1921 letter Einstein writes: "The perihelial movement of Mercury is the only anomalous one in our planetary system which has been sufficiently attested" (*Gravitation versus Relativity*, pp. 185-186).

¹⁴⁹⁶ *Gravitation versus Relativity*, p. 187.

¹⁴⁹⁷ Physicist Tom Van Flandern. Article written by Tom Bethel, "Rethinking Relativity," *The American Spectator*, April 1999.

of the astronomical investigations into the motions of Mercury are summed up as: “it was found (Leverrier – 1859 – and Newcomb – 1895) that an unexplained perihelial movement of the orbit of Mercury remained over, the amount of which does not differ sensibly from the above mentioned +43 seconds of arc per century. The uncertainty of the empirical result amounts to a few seconds only.” Leverrier in 1859 found 38"; Newcomb in 1895 found 41.6"; quantities quite different from the 43" quoted by Einstein...The coincidence of figures, the supposed agreement between observation and the relativity theory, vanishes the moment the real facts are stated.¹⁴⁹⁸

The caveat for Einstein is that once he chooses 43" as the final figure it cannot be changed in the future due to the equations he formulated from the General Relativity theory. Thus, if the real figure turns out to be anything more or less than 43", Relativity is automatically disqualified as providing an explanation to Mercury's perihelion. As Relativist Clifford Will admits: "...the prediction of general relativity is fixed at 43 arcseconds; it can't be fiddled with."¹⁴⁹⁹ Poor adds: "There is no flexibility in the Einstein formulas, no constant of uncertain value, no possibility of adjustment."¹⁵⁰⁰ Being caught in such a corner, Relativists will create quite a fuss over anyone who has claims to an alternate figure, as we shall see below.

It is worthy of note that already in 1898 Paul Gerber had produced the equation that accounted for the precession of Mercury, obviously, without any use of Relativistic tensor equations since they would not be available for use until 1916. Gerber did, however, use the assumption of Einstein's General Relativity, that is, gravity traveled at the speed of light. Gerber published his finding in Mach's *Science of Mechanics*. It wasn't until Einstein published the same equation in *Annalen der Physik* 18 years later that the editors of *Annalen* reprinted Gerber's equation, pointing out that Einstein should have given credit to Gerber. Although he was an avid reader of Mach's writings, Einstein claimed ignorance of Gerber's previous work (the same reason he gave when it was discovered that his Relativity equation was identical to Lorentz's Transformation equation produced 10 years earlier).

Subsequent calculations of Mercury's perihelion were made after Einstein supported the 43" figure. In 1930, the figure was raised to 50.9.¹⁵⁰¹ Just prior to the 1960s, it was set back at 32.0. These wide-ranging values are due to the procedural difficulties stemming from having to account for all the mass and movements in the solar system. In

¹⁴⁹⁸ *Gravitation versus Relativity*, p. 187.

¹⁴⁹⁹ *Was Einstein Right?*, p. 101.

¹⁵⁰⁰ *Gravitation versus Relativity*, p. 187.

¹⁵⁰¹ H. R. Morgan, *Journal of the Optical Society of America*, 20, 225, April 1930.

reality, depending on how one views or juggles the figures, one can make the residual perihelion vary quite extensively. Charles Lane Poor shows, for example, that the original calculations by Leverrier had the perihelion of Mercury literally dancing in the sky. He writes:

The extreme complexity of the problem may be best illustrated by giving the actual expression for the position of the perihelion of Mercury, as affected by the action of Venus alone. This is taken from the work of Leverrier... These show that from February 25 to July 19 the perihelion was moving backward, while during the next period it was moving forward, but on December 10th it was still behind where it had been earlier in the year. All this is complicated enough, but it only accounts for the action of Venus; it requires twenty-one similar terms to account for the action of the Earth, sixteen for Jupiter, six for Saturn, and one for Uranus.¹⁵⁰²

By the 1960s, the figure was put at 39.6. Astronomer [Robert Dicke](#) (an important figure in his own right as he superseded the crucial experiments of Roland von Eötvös) proposed, after his intensive study, that the oblateness of the sun was responsible for a significant portion of the residual perihelion of Mercury. Dicke and his partner Goldenberg found that the sun's polar axis is shorter than its equatorial axis by approximately 40 parts per million, thus making the sun oblate, and accounting for at least 3.4" of the residual perihelion of Mercury.¹⁵⁰³ This new evidence brought the residual down from 43.0 to 39.6, thus making Einstein's attempt at securing 43" through General Relativity somewhat dubious. Moreover, Dicke's adjustment of 3.4 arc seconds could just as easily been used to offset the 50.9 or the 32.0 figures, thus making them 47.5 and 28.6, respectively.

Robert Clark describes the outcome of Dicke's work: "Dicke began a series of experiments in the mid-1960's whose results brought a headline in *Nature* of 'Einstein in Crisis?'"¹⁵⁰⁴ *Nature* followed in the article stating:

In spite of the great aesthetic and philosophical appeal of Einstein's general theory of relativity, it is still, after 50 years of widespread acceptance, one of the least well-founded

¹⁵⁰² *Gravitation versus Relativity*, p. 143.

¹⁵⁰³ "Solar Oblateness and Gravitation," *Gravitation and the Universe*, pp. 30f. In a report dated January 13, 1967, to the American Physical Society, Dicke and Goldenberg report: "New measurements of the solar oblateness have given a value for the fractional difference of equatorial and polar radii of $(5.0 \pm 0.7) \times 10^{-5}$. A corresponding discrepancy of 8% of the Einstein value for the perihelion motion of Mercury is implied" (*Physical Review Letters*, 18, 313). NB: 8% of 43.0 is 3.4.

¹⁵⁰⁴ *Nature* 202, 1964, pp. 432f.

theories in physics as far as experimental confirmation is concerned.¹⁵⁰⁵

Some astronomers, lending their support to Relativity, doubted Dicke's findings, arguing that the sun's oblateness could not account for such a large portion of the residual perihelion. Suffice it to say, the war was now in full swing. Dicke was definitely a threat to Relativity, since a deviation as large as 3.4" would immediately topple General Relativity. In 1974, Dicke published a complete reanalysis of the data, and came up with the same result.

Afterward, Dicke and several other astronomers found that in addition to the oblateness, the sun's gravitational quadrupole moment, its rapid internal rotation, and its oscillations in diameter and rate of rotation, all play a part in determining the residual figure of 39.6 arc seconds. If the sun's inner core rotates faster than its exterior, this will cause a precession of the orbits of the planets and explain a significant portion of the residual perihelion. Dicke postulated that the interior core of the sun, at least out to one half its radius, rotates twenty times faster than the exterior. Ian Roxburgh was one of the first to make this evidence public. His abstract reads:

The hypothesis that the inside of the Sun is rotating much more rapidly than the surface layers...The angular velocity of the inner region is estimated and it is shown that the rotational distortion of the Sun produces a perihelion advance of the planets. If the angular velocity inside the Sun has the same magnitude as in a typical rapidly rotating star, then the anomalous advance of the perihelion of Mercury, usually counted as one of the crucial tests of general relativity, can be explained by the gravitational effect of the rotating Sun.¹⁵⁰⁶

Subsequent experiments performed in 1973-1982 by Henry Hill gave results that were five times smaller than Dicke's but still fifty-times larger than the conventional value. Dicke came back in 1985 with further experiments and stated that the results yielded 12 parts per million rather than the original 40 parts per million.¹⁵⁰⁷ These results show the extreme

¹⁵⁰⁵ Einstein: *The Life and Times*, p. 767.

¹⁵⁰⁶ Ian W. Roxburgh, "Solar Rotation and the Perihelion Advance of the Planets," *Icarus*, 3:92, 1964.

¹⁵⁰⁷ R. H. Dicke, J. R. Kuhn, K. G. Libbrecht, "The variable oblateness of the Sun: measurements of 1984," *Astrophysical Journal*, 311, 1025-1030 (1986); R. H. Dicke, J. R. Kuhn, K. G. Libbrecht, "Is the solar oblateness variable? Measurements of 1985," *Astrophysical Journal*, 318, 451-458, 1987; J. R. Kuhn, K. G. Libbrecht, "Oblateness of the Sun in 1983 and Relativity," *Nature*, 316, 687-690, 1985; L. Campbell, J. C. McDow, J. W. Moffat, D. Vincent, "The Sun's Quadrupole Moment and Perihelion Precession of Mercury," *Nature* 305:508, 1983; Anna Maria Nobili and Clifford M.

difficulty in obtaining accurate and reliable results. As Relativity supporter Clifford Will admits: “It is ironic that after seventy years, Einstein’s first great success remains an open question, a source of controversy and debate.”¹⁵⁰⁸

In the face of the foregoing evidence, there has been an inordinate amount of pressure put on the scientific community not only to maintain a residual perihelion for Mercury of 43 arc-seconds, but to attribute it solely to General Relativity and to minimize any findings from the sun’s inherent characteristics that provide an alternative answer.

In the face of these difficulties, some have suggested using the perihelia of Venus, Earth or Mars to help prove Relativity theory. But this presents an even worse dilemma for Relativity, considering the anomalous results of Einstein’s predictions for the perihelia of the other planets. Indeed, it is puzzling why Relativists would want to open this Pandora’s Box at all. Perhaps they are hoping that no one will investigate the original records of Relativity’s predictions, but, unbeknownst to most, the investigation has already been done. A person close to the scene and one who obtained General Relativity’s original perihelia predictions was celestial mechanic Charles Lane Poor of Columbia University. Poor first reveals Einstein’s admission: “The only secular perturbation is a motion of the perihelion.”¹⁵⁰⁹ Poor interprets this statement as follows:

Thus the relativity theory cannot explain, or account for, any of the observed discrepancies in the motions of the planets, other than those in the perihelia. But it is clear that, under the Relativity theory, the perihelia of all the planets must rotate by various amounts depending upon their respective distances

Will, “The Real Value of Mercury’s Perihelion Advance,” *Nature* 320, 39-41, 1986; D. O. Gough, “Internal rotation and gravitational quadrupole moment of the Sun,” *Nature*, 298, 334-339, 1982; S. Pireaux, J. P. Rozelot, S. Godier, “Solar quadrupole moment and purely relativistic gravitation contributions to Mercury’s perihelion Advance,” *Astrophysics and Space Science* 284, 1159-1194, 2003; M. Bursa, “The Sun’s flattening and its influence on planetary orbits,” *Bulletin of the Astronomical Institute Cze.*, 37, 5, 312-313, 1986; J. V. Narlikar, N. C. Rana, “Newtonian N-body calculations of the advance of Mercury’s perihelion,” *Notes of the Royal Astronomical Society* 213, 657-663, 1985; Ronald L. Gilliland, “Solar Radius Variations over the Past 265 Years,” *Astrophysical Journal* 248:1144, 1981; “The Sun Shivers on a 76 Year Cycle,” *New Scientist*, 92:165, 1981; David W. Hughes, “Solar Size Variation,” *Nature* 286:439, 1980; David W. Dunham, *et al*, “Observations of a Probable Change in the Solar Radius between 1715 and 1979,” *Science* 210:1243, 1980; Leif M. Robinson, “The Disquieting Sun: How Big, How Steady?” *Sky and Telescope*, 63:354, 1982; S. Sofia, *et al*, “Solar Radius Change between 1925 and 1979,” *Nature* 304:522, 1983.

¹⁵⁰⁸ *Was Einstein Right?* p. 107.

¹⁵⁰⁹ As quoted in *On Einstein’s Theory of Gravitation and its Astronomical Consequences*, by W. de Sitter, in *Monthly Notices*, Royal Astronomical Society, vol. lxxvi, No. 9, p. 726, as cited in *Gravitation versus Relativity*, p. 190.

from the sun. The amounts of such rotations can be readily calculated from the formula given by Einstein for the case of Mercury.

Poor then shows that Einstein's results vary widely from those of Newcomb. For example, Relativity would predict a +8.6" perihelion for Venus, but Newcomb recorded -7.3". In other words, Relativity would predict a perihelion for Venus that was going in the opposite direction of what was actually observed. As Poor describes it:

The perihelion of this planet is rotating more slowly than the computations indicate it should, the difference being -7.3" per century. The Einstein formulas would increase the theoretical speed of rotation by an additional 8.6", thus making the total discrepancy between observation and theory 15.9 or 37% of the entire observed motion. The Einstein formulas, in this case, make a bad matter worse; they give the orbit a rotation in the direction opposite to that which is required to fit the observations. Thus the Relativity theory is not sufficient to explain the discordances in the planetary motions. It accounts approximately for only one among the numerous discrepancies that of the perihelion of Mercury. It fails completely to explain any position of several well-tested irregularities and it doubles the observed discrepancy in the motion of Venus.¹⁵¹⁰

Some advocates of Relativity attempt to cover up these inconsistencies, as seen, for example, in Hugh Ross' assertion that General Relativity found a precession for Venus of "8.6," a figure, according to his endnotes, that he obtained from Steven Weinberg's *Gravitation and Cosmology*.¹⁵¹¹ Perhaps because they were trying to save face for Relativity theory, neither of the two authors mention the observational figure of -7.3.

Poor also reports that Einstein's Relativity predicted a perihelion for Mars of +1.3", but the observational figure is +8.1", a difference of 623%.¹⁵¹² Not surprisingly, Weinberg and Ross leave out General Relativity's anomalous prediction, replacing it with the precession of the asteroid Icarus.¹⁵¹³ Einstein's formula also makes an erroneous

¹⁵¹⁰ *Gravitation Versus Relativity*, New York: Putnam and Sons, 1923, p. 194.

¹⁵¹¹ *Gravitation and Cosmology*, New York: John Wiley, 1972, p. 198. Ross says that the observed value of Venus' perihelion is "8.4" ± 4.8" and that General Relativity's prediction was "8.6".

¹⁵¹² *Gravitation Versus Relativity*, p. 191. In addition, the observed value of Mercury's Nodal precession is +5.1 ± 2.8 and Venus' is +10.2, whereas Relativity calculated zero for both.

prediction of Earth's perihelion, assigning a figure of +3.8" when, according to heliocentric mechanics, it is actually 5.9". Also, Newcomb was able to measure the nodes of Mercury (5.1") and Venus (10.2") as well as the eccentricity of Mercury (0.88"), but Einstein's formula simply isn't able to make such calculations with a value greater than zero.

Other anomalies in Relativity's ability to calculate the perihelion of the heavenly bodies crop up from time to time. For example, for the binary DI Herculis, composed of two stars which circle each other in about 10.5 days, General Relativity predicts that the orbit should rotate by 4.27° per century, but the actual value is 1.05° . Many such discrepancies occur in other binary systems.¹⁵¹⁴ The discrepancies are more frequent when the gravitational field is stronger, as it is in binary systems, yet ironically General Relativity was invented in order to explain the phenomenon of gravity.

Lastly, Poor wrote two devastating critiques of Einstein's use of the perihelion of Mercury to prove Relativity theory. The first was written in 1923 titled "Relativity: An Approximation," presented to the American Astronomical Society; the other in 1924 titled "The Relativity Motion of Mercury: A Mathematical Illusion," presented to the Physics Colloquium of Columbia University. The former is included at the end of this Appendix.

The Brans-Dicke Challenge to Einstein

In the 1960s, one of the premier astronomers of the day, Robert H. Dicke, put forth a challenge to General Relativity based on Mach's principles. Our purpose in revealing the challenge, however, is not to propose that Brans-Dicke offered a viable alternative to General Relativity; rather, it is to show that the new theory forced Relativists to cease basing their theory merely on mathematics and demanded that they provide the world with real physical evidence for their beliefs. For our interests, it matters little which theory eventually wins in the minds of modern scientists. Rather, our interest lies in seeing one form of relativity challenge another form, and in the process, expose both for the erroneous concepts they present.

Robert Dicke's first challenge to General Relativity regarded the perihelion of Mercury. Dicke found that, contrary to the theory of General Relativity, part of Mercury's residual perihelion was due to the sun's oblateness as well as its fast rotating inner core. With Carl Brans,

¹⁵¹³ *The Fingerprints of God*, p. 46. Icarus, technically known as 1566 Icarus, is an asteroid discovered by Walter Baade in 1949. Its orbit intersects the sun-Earth semi-major axis.

¹⁵¹⁴ Robert Naeye, "Was Einstein Wrong?" *Astronomy*, 23:54, 1955, as cited in *The Biblical Astronomer*, Vol. 6, No. 77, 1996.

Dicke put forth another challenge, much more formidable. Based on Mach's principles, they offered a theory of gravity which was opposed to the one established by General Relativity.¹⁵¹⁵ They posited that the gravitational force between two bodies should be determined not only by the two bodies themselves, but also by the distant matter in the universe (e.g., stars, galaxies, etc.).¹⁵¹⁶ In effect, as Brans writes, they were proposing "to find a physical basis for inertial reaction forces,"¹⁵¹⁷ a force of nature that had eluded a convincing explanation from the time of Aristotle, through Newton and down to Einstein. Dennis Sciama had also suggested the same in 1953.¹⁵¹⁸ To the consternation of General Relativity advocates, the Brans-Dicke theory has a built-in mathematical variable that will not allow the theory to be disproved.¹⁵¹⁹ As Clifford Will describes it:

¹⁵¹⁵ C. Brans and R. H. Dicke, "Mach's principle and a relativistic theory of gravitation." *Physical Review* 124 (1961): 925-35. SCI reported that Brans and Dicke's article was cited in over 565 publications between 1961 and 1983. See also R. H. Dicke, "Dirac's cosmology and Mach's principle," *Nature* 192 (1961): 440-41.

¹⁵¹⁶ Dicke wrote in his autobiography: "...the laboratory, Earth and Solar System could not be isolated even in principle from the rest of the universe" (*R. H. Dicke, A scientific autobiography*, unpublished manuscript on file in the Membership Office of the National Academy of Sciences, 1975). Dicke proposed considering the gravitational constant, G , as the ratio of gravitational to inertial mass. As Brans put it: "Any influence of the universe structure on inertial forces would then show up in terms of G , expressed in 'standard' units for which inertial mass is defined as constant. This also was consistent with Dirac's conjecture $1/G \sim M/R$." To calculate the gravitational effect of the universe on two bodies, one would need to determine the radius of the universe, multiply the radius by the square of the speed of light, and then divide the result by the mass of the universe, and then multiply by the volume of a sphere. The resulting number should equal the gravitational constant, G , which is $0.0000000667 \text{ cm}^3/\text{grams}/\text{second}^2$. Dicke came within a factor of 100 using a 10 billion light-year radius and 200 grams per cubic million kilometers. Of course, if Dicke's radius is decreased and the grams/million kilometers³ increased in line with the parameters of a smaller yet denser geocentric universe, the resulting factor would be a lot closer to the gravitational constant. For example, attaining G for a 90 parsec radius universe, the mass of the universe is 1.31×10^{61} grams.

¹⁵¹⁷ Carl H. Brans, "Citation Classic," in *Current Contents*, March 7, 1983, p. 24.

¹⁵¹⁸ Dennis W. Sciama, "On the Origin of Inertia," *Monthly Notices of the Royal Astronomical Society*, 113:34-42, 1953; and *The Unity of the Universe*, New York, Doubleday, 1961.

¹⁵¹⁹ As Brans put it: "I started from this point, looking for field equations which would contain $1/G$ as a field quantity, and having mass as a source. A simple division of the Einstein Lagrangian by G , to isolate it from the matter Lagrangian, so that matter will be conserved as usual, came to mind quickly as a starting point. An extra term, involving ϕ and its derivatives, must then be added with its form determined by dimensional arguments. However, its numerical coefficient could not be determined and was left as a free dimensionless constant. Standard Einstein theory is recovered in the limit as this constant, ω , approaches ∞ . Thus, in principle, with no independent guide to the value of ω , no experiment with finite error can rule out the scalar-tensor

...the scalar-tensor theory was every bit as valid mathematically as general relativity, and was capable of making detailed predictions for the outcomes of experiments...the theory could do anything general relativity could do.¹⁵²⁰

Although various experiments were performed to distinguish between General Relativity and Brans-Dicke, the precision needed to do so was so high that it simply was not feasible. As Clifford Will puts it:

The problem of Mercury's perihelion shift and the solar oblateness remained unresolved; if anything it was now even more contentious, because the prediction of the Brans-Dicke theory with ω larger than 500 for Mercury's perihelion shift is indistinguishable from that of general relativity, so if the solar oblateness were to be as large as the original Dicke-Goldenberg 1966 value, both theories [General Relativity and Brans-Dicke] would be in violation of experiment. Could one say that the scalar-tensor theory was completely dead? Not exactly. Because ω is adjustable, the predictions of the theory can be made to be as close as desired to those of general relativity....At this point a certain subjectivity must enter the decision as to what is viable and what isn't.¹⁵²¹

What Will suggests as the judge of the issue is Occam's razor, claiming that General Relativity is the simpler approach. In the end, Will has no proof to protect Einstein's theory. He is left with relativistic mathematical formulae against relativistic mathematical formulae, both formulas claiming to provide the definitive answer, yet neither being able to disprove the other by direct physical evidence.

theory in favor of Einstein's" (Carl H. Brans, "Citation Classic," in *Current Contents*, March 7, 1983, p. 24).

¹⁵²⁰ Clifford Will, *Was Einstein Right?*, p. 154. Will relates that "...the joke that used to go around Kip Thorne's relativity research group at Caltech: On Monday, Wednesday, and Friday, we believe general relativity; on Tuesday, Thursday, and Saturday, we believe the Brans-Dicke theory (on Sunday, we go to the beach)" (*ibid.*, p. 156).

¹⁵²¹ Clifford Will, *Was Einstein Right?*, p. 158.

Relativity: An Approximation

By Charles Lane Poor¹⁵²²

The generalized theory of relativity has been accepted as proved; proved by the motions of Mercury and by the bending of light rays near the edge of the sun; phenomena that, according to the relativists, cannot be explained or accounted for by the ordinary methods of astronomical research. Now, how does the relativity theory explain these motions of Mercury, this deflection of light? In what way do the formulas of relativity differ from those of the old fashioned classical mathematics of Newton, La Place, and Leverrier?

The formula of relativity, upon which is based the relativist's explanations of these phenomena, is found, upon analysis, to be nothing more nor less than an approximation towards the well known formula of Newtonian mathematics. The relativity formula, as used in the astronomical portion of the theory, contains not the slightest trace of the basic postulates of relativity, of warped space, or the mythical fourth dimension. It is a formula of Newtonian gravitation, purely and simply; but an approximate formula, derived by a series of approximations.

In deriving the formulas for the transmission of light throughout space and for the motion of one particle of matter about another, the relativity mathematician encounters a serious difficulty. His formula, derived from the postulates of relativity, indicates that light travels with different speeds in different directions, that the velocity of light depends upon the direction of transmission. That such a mathematical result represents the facts of nature is highly improbable, for in free space there is no difference between right and left, between north and south, or east and west; there is no reason why a ray of light should travel faster to the north than to the south. To overcome this mathematical difficulty, or inconvenience, as he calls it, the relativist makes a substitution, or approximation. Instead of using the direct distance between the centers of two particles of matter, the relativist adds a small, a very small, factor to this distance; or, as Eddington puts it, "*we shall slightly alter our coordinates.*" Such an approximation is very common among physicists: it is done every day to simplify troublesome formulas. The only precaution necessary in such a procedure is to remember always that the final result is necessarily approximate, and, before drawing any conclusion, to thoroughly test the effects of the approximation.

Now the quantity, m , which is thus added to the distance to simplify the relativity equation, represents the mass of the attracting body, expressed in linear relativity units. It is really very small indeed in all physical problems of the laboratory. For all ordinary masses of

¹⁵²² A paper presented to the American Astronomical Society, 13th meeting, 1923, Mount Wilson Observatory, California.

matter, such as can be handled and experimented with on the earth, this little quantity is very much less than the billionth part of an inch; for the earth itself it is only about one-sixth ($1/6$) of an inch. As applied to the earth as a gravitational body, the approximation really consists in adding $1/6^{\text{th}}$ of an inch to each and every distance measured from the center of the earth. As the radius of the earth is some 4,000 miles, it is easy to see that for bodies near the surface of the earth this approximation amounts to less than one part in a billion, a quantity absolutely inappreciable in any physical problem; in the case of the motion of the Moon about the earth, this little distance is less than one part in seventy-five billion.

To the physicist such a degree of approximation is amply sufficient; no laboratory methods can measure with this degree of accuracy. But it is radically different in astronomy: distance and motion are on enormous scales and time continues on interminably, and a minute approximation might become evident in the motions of the planets.

Now it must be clearly understood that this minute approximation is the *sole appreciable difference* between the so-called Einstein law of motion and the old fashioned mathematics of Newton. By omitting this approximation and using the exact distance between the centers of the two bodies the Einstein formula becomes identical with that of Newton: on the other hand, if, in the Newtonian formula the approximate distance be used, then this formula becomes identical with Einstein's. There is no essential difference between the two formulas: Einstein's formula is an approximation towards Newton's; except for the approximation, it is Newton's. In the Einstein formula for the orbit of a planet there is not the slightest trace of relativity; there is no warped space, no fourth dimension; there is nothing but every-day, ordinary Newtonian gravitation, but *approximate gravitation*. The approximation is in the Einstein equation; not in the Newtonian.

When the motions of the planets about the sun are considered, it must be remembered that the sun is many thousands of times larger than the earth, and, therefore, the little quantity, m , becomes proportionally larger, being in fact about nine-tenths of a mile. And the relativity approximation consists, in this case, of using in their formulas, not the actual distance of a planet from the center of the sun, but that distance increased by nine-tenths (0.91) of a mile. This same distance, this $9/10^{\text{th}}$ of a mile, is added to the distance of each and every planet, to that of Mercury, to that of Venus, of Jupiter and of Saturn. In all real astronomical work the position of the center of a planet is always determined from the center of the sun; the center of the sun is the fundamental point of reference in the solar system. No other point is ever used in actual astronomical observations, calculations, or tables; the actual distance of a planet from this point is measured, or calculated, or tabulated. But the relativity approximate formula does not give this actual distance: in the case of each and every planet it gives this distance increased by $9/10^{\text{th}}$ of a mile.

The Motion of the Perihelion of Mercury

It is this approximation, which gives rise to the apparent, or so-called Einstein motion of an elliptic orbit. According to the Newtonian formula the elliptic orbit of a planet (when the interaction of the other planets is omitted) is fixed in space; according to the Einstein formula the elliptic orbit is in slow motion, so that the perihelion appears to advance. But the Newtonian formula is mathematically exact; the Einstein formula contains an approximation, and the apparent theoretical Einstein rotation of an orbit, the theoretical Einstein advance of the perihelion is due, entirely, to the approximation so contained in his formula. The theoretical orbit of a planet is fixed in space, as shown by the mathematically exact Newtonian formula; there is no Einstein motion of the perihelion; the so-called Einstein rotation of an orbit is a mathematical illusion, caused by using an approximate formula.

But, while the Einstein motion is pure illusion, there is an actual motion of the perihelia of all the planets. When the mutual interactions of the planets, one upon another, are taken into account, then it is found that the orbits of all of them are in motion; the simple elliptic orbits writhe and squirm, so to speak, under the additional forces of the planets themselves. Not a single orbit is at rest, not a single orbit is a true ellipse. The orbit of Mercury, for example, swings around at the rate of 576 seconds of arc per century; that of Mars at the rate of 1606 seconds per century. Leverrier in 1859 computed the action of each and every planet upon the orbit of Mercury, and found that these attractions would account for only 538 seconds or arc, thus leaving an unexplained 38 seconds in the centennial advance of Mercury's perihelion. This is the celebrated discordance, which has been so stressed by Einstein and is followers. Leverrier explained it by the action of an unknown planet, or of masses of matter, between Mercury and the sun. While it is now known that no large planet is there, yet observations and photographs, without number, show clearly the presence of great masses of scattered matter in the very places that Leverrier indicated as necessary to explain this motion of Mercury.

But the relativity approximate formula gives rise to an apparent, or fictitious, motion of the orbit of Mercury of some 43 seconds of arc per century. And it is this approximate coincidence of figures, 43 seconds of illusion as against 38 seconds of actuality, which has been used by Einstein and is followers as proof, conclusive, of the relativity theory. As the relativity advance, as this 43 seconds, is a mere mathematical illusion, as there is, in reality, no such thing as the Einstein rotation of an orbit, this approximate coincidence of figures has no bearing, whatsoever, upon the truth or falsity of the relativity postulates.

The Deflection of Light

There is nothing new in the idea that light may be bent, or deflected, from its course by the action of gravitation. Sir Isaac Newton certainly suspected that bodies might act upon light at a distance, and by their action bend its rays. Such action and such bending, of course, was predicated upon the theory that light consists of material particles of matter, shot forth from the luminous source. Such a material particle, or corpuscle, passing near the sun or other large gravitational mass would naturally describe a planetary orbit about such body, and the bending of the ray would be the amount of curvature in such orbit. The character of the orbit and the amount of curvature, or bending, of the orbit depends entirely upon the velocity with which the particle passes the attracting body. At a certain rather low velocity, the path of the particle is a circle about the gravitating centre: as the velocity increases the circle becomes an ellipse, a parabola, and finally an hyperbola. With each further increase in speed the arms of the hyperbola open out more and more and the path approaches nearer to a straight line.

The velocity of light is so great that the path of a particle, traveling about the sun with that speed, will be an hyperbola, the arms of which are so widely separated as to make the path almost, but not quite, a straight line.

The corpuscular theory of light, as held by Sir Isaac Newton, explained all the optical phenomena known to him. But, during the years which elapsed after his death, new facts were learned and new experiments made. Facts and experiments, which could not be explained or accounted for on this theory, gradually led to the acceptance of the then rival, wave or undulatory, theory of light. With the passing of years, with each new experiment, the wave theory of light became more and more firmly established, until it became one of the fundamental theories, or concepts, of modern science.

Therefore von Soldner's paper on the bending of light rays, which was published in 1801, attracted very little attention. For in this paper he assumed the corpuscular theory of light and calculated the amount that a ray should be bent in passing near the sun. He treated light as being material, a particle of light being attracted by the sun in the same way as a planet, and obeying the same laws of motion. He treated the problem of finding the light deflection in exactly the manner one would treat the path of a minute planet, which travels about the sun with the speed of light. He applied to the problem the ordinary, every-day, formulas of Newtonian gravitation.

It can be readily shown that, under the Newtonian laws of motion, a minute planet, traveling about the sun with the speed of light in a path which just grazes the surface of that luminary, will travel in an hyperbolic orbit; in a curve which is almost, but not quite a straight line. A very simple calculation shows that the total amount of bending in such path amounts to only 0.87 seconds or arc. This is the so-called

“Newtonian” deflection. If the Newtonian, or corpuscular theory of light be true then all rays of light, grazing the edge of the sun, will be bent, or deflected from their straight paths by this amount, by 0.87 seconds of arc.

Now Einstein, in his generalized theory of relativity, introduces a factor two (2) into the formula for the bending of light rays, and gives the total deflection of a ray, passing the sun, as double the above amount, are as 1.75 seconds of arc. This theoretical Einstein bending of a light ray is found, by Eddington and others, from the relativity equations by the use of the celebrated principle of equivalence. Under this principle of relativity, the track of a ray light “*agrees with that of a material particle moving with the speed of light.*” The principle of equivalence, so stated, appears to be nothing more nor less than an assumption of the truth of the corpuscular theory of light; yet the relativist never distinctly acknowledges this assumption, never distinctly states which theory of light is to be accepted. To explain certain phenomena the wave theory seems to be used by the relativists; other phenomena, under the principle of equivalence, by the corpuscular theory. Is not the principle of equivalence, so used, a handy device for passing readily from one theory to another as necessity drives?

But let us assume, with the relativist, the validity of the principle of equivalence, and from this principle find from the relativist’s own formulas the track of a ray light. The fundamental formula of relativity dynamics is given by Eddington and it differs from that of Newtonian mathematics by a single small term (which has been shown to be the result of an approximation). From this fundamental differential formula the relativist finds the path of a planet, and the track of a ray of light; finds the motion of the perihelion of Mercury, and the deflections of the rays from distant stars as they pass near the eclipsed sun. According to the principle of equivalence there is no essential difference between these two cases: Mercury travels about the sun at the distance of many millions of miles and at a comparatively slow speed; the ray of light grazes the edge of the sun and travels at a terrific velocity. But the same formula applies to both cases; substitute in it the speed and distance of Mercury for the motions of Mercury; substitute in it the speed and distance of the ray of light and obtain the track of such ray.

Now Eddington integrates this fundamental equation of relativity dynamics and finds the complete path of any body, Mercury, Jupiter, or a material particle travelling with the speed of light. This complete and general orbit of any body, of Mercury or of a ray of light, is given by Eddington in his discussion of the motion of the perihelion of Mercury, and this orbital equation of relativity, so given by Eddington, differs from the ordinary equation of celestial mechanics by a single small term, by the term which gives rise to the so-called relativity motion of the perihelion. According to repeated statements of Einstein, of Eddington and of other relativists, according to the printed formulas of relativity,

the relativity orbit, or path of a body is identical with that of Newtonian mathematics, with the single exception of this perihelial motion. This complete formula for the orbit of a body is used by the relativists to find the so-called motion of the perihelion of Mercury, to find the celebrated 43 seconds of arc, upon which is based the Mercurial proof of the Einstein theory.

But, upon the equivalence principle, this same orbital equation should give the track of a ray of light, passing near the sun. Substituting in this equation the distance of the ray from the sun's centre and its speed, the resulting orbit, or track of a ray is an hyperbola, and the total deflection, or bending is easily shown to be 0.87 seconds of arc, agreeing identically with that found from the Newtonian equation. This is necessarily so, for the two equations are the same, with the exception of the small term, which gives rise to the motion of the perihelion. In the case of Mercury, this minute term appears to give a motion of the perihelion of 0.103 seconds of arc in one revolution of the planet in its orbit (42.7 seconds per century): in the case of a ray of light, the same term amounts to about only *thirty-five millionths* (0.000,035) of a second of arc, a quantity absolutely negligible.

That is, the very formula, used by the relativists to prove their theory by the motion of Mercury, *disproves* their computed value for the light deflection. This equation, their own equation, gives the so-called Newtonian value, 0.87 seconds of arc, for the bending of a ray of light by the gravitational action of the sun.

The relativist, however, does not use this orbital equation in his calculations of the amount of the light deflection. He reverts to the fundamental differential equation and integrates it in an entirely different manner for the track of the light ray. This second method of integrating the fundamental equation is, however, frankly approximate and gives a result which applies solely to light. Before beginning the integration, Eddington discards a term from the fundamental equation as being, in the case of light, infinitely small in comparison with other terms in the equation. This simplifies the equation, and the integration of the thus mutilated equation results in a curved path, which may approximate that of a light ray, but which is clearly approximate. The total bending, resulting from the use of this approximate path, is the relativity figure of 1.75 seconds of arc.

The validity of this method depends upon the question as to whether the discarded term is really very small with respect to those retained, or not. The omitted term is a constant, while the value of the term retained varies with the movement of the light particle along the curved orbit. A very simple comparison¹¹ of this rejected term with the one retained shows that, in the most favorable case, the term, I/P , which Eddington omits as negligibly small, is two-thirds (2/3rds) as great as the term which he retains. Two-thirds can hardly be called negligibly small in comparison with unity. Further, except for a minute portion of the

curve near perihelion, the omitted term $1/P$ is actually very much *larger* than the term, $3\mu^2$, which is retained. Eddington, in fact, omits as negligibly small, the large, important term of the equation, and retains the insignificant term.

It would thus seem that the approximation used by Eddington to integrate the equation for the deflection of light is *invalid*, and that the resulting value for the bending of the light ray is erroneous.

Both methods of integrating the fundamental relativity equation cannot be right: one or the other must be wrong. The first and more general method, as we have seen, is used by the relativist to obtain the so-called relativity motion of the perihelion of Mercury, but this method gives the deflection of light only 0.87 seconds of arc; the second method is restricted to light, is frankly approximate, and gives the amount of the deflection as 1.75 seconds. The same equation is handled by the relativist in two different ways and gives two radically different results. Which result is correct?

The relativist apparently checks his invalid calculation by the use of an entirely different method, a physical method of determining the deflection. But the method is faulty and contains obvious errors, and the fundamental formula for the velocity of light, upon which the entire method is based, is in direct contradiction to the principle of equivalence, for it shows that the speed of light *decreases* as it approaches the sun, while the equivalence principle demands that such velocity should increase.

It would thus seem that the calculations by which Eddington finds the deflection of light equal to 1.75 seconds of arc are invalid. The principle of equivalence, if true, shows that the total bending of a ray of light, passing near the sun, is 0.87 seconds of arc, and not the 1.75 seconds, as claimed by the relativists.

Conclusions

1. The fundamental formulas of relativity dynamics contain an approximation; the r of these formulas is not the direct distance between the centres of two particles of matter; it is this distance increased by a minute quantity.
2. The relativity formulas can be obtained directly from the corresponding Newtonian formulas by the introduction of the relativity approximation.
3. The relativity motion of the perihelion of an orbit is a mathematical illusion, due entirely to the use of the relativity approximation. The elliptic orbit of a particle of matter is fixed in space (when the interaction of the other planets is omitted).

4. The supposed confirmation of the Einstein theory by the motion of the perihelion of Mercury depends entirely upon the use of the approximation in the relativity formulas: when the approximation is removed from the formulas, all appearances of confirmation vanish.
5. Under the generalized theory of relativity, through the principle of equivalence, a ray of light, passing near the sun, will be bent by the same amount as under the corpuscular theory of light. The theoretical bending being thus the same for these two theories, a deflection, observed at an eclipse, cannot be used to prove the truth of the relativity theory as against that of the corpuscular theory of light.
6. The figure, 1.75 seconds of arc, given by the relativists for this deflection is obtained by approximate and invalid calculations. The relativists own formulas give, as they should under the principle of equivalence, 0.87 seconds, and not 1.75.

The amount of deflection observed at the 1922 eclipse cannot be explained, either by the Einstein theory or by the corpuscular theory of light. Such deflection, if confirmed by later eclipses, will have to be explained on other grounds, by some purely physical cause, or by a combination of causes.

Appendix 6

Does the Hefele-Keating Experiment Prove General Relativity?

Ever since Einstein proposed his General Relativity theory in 1916 the science community has been trying to offer observable proof for its claims. The bending of light near the sun, the residual perihelion of Mercury, the time dilation of μ -mesons and a few other candidates, have tried but failed to provide convincing proof. As noted earlier, it is not difficult to make it *appear* as if proof exists, since the mathematics on either side of the equation can easily be adjusted to fit with the proposed theory. Accordingly, Relativist Clifford Will admits: “General Relativity has passed every solar-system test with flying colors. Yet so have alternative theories.”¹⁵²³ Obviously, the mathematics of General Relativity and the “alternative theories” all work, but at most only one theory can represent the true reality. Besides mathematics, however, there are other “adjustments” that scientists employ to get the “right” result. Such is the case with the Hefele-Keating experiment.

As we know, Relativity proposes that time runs slower for an object in motion than for an object at rest. To help prove this postulate, in October 1971, J. C. Hefele and Richard E. Keating placed cesium beam atomic clocks upon commercial jets, having one jet fly eastward and one jet fly westward.¹⁵²⁴ To minimize the effects of the Earth’s magnetic field, the clocks were triple-encased. Another clock was placed at ground level and kept in place at the United States Naval Observatory. When the clocks were compared, Hefele and Keating reported that the flying clocks differed from the ground clock within the margin of error predicted by the theory of Relativity. According to Relativity, the eastbound clock should have lost 40 ± 23 nanoseconds while the westbound clock should have gained 275 ± 21 nanoseconds. The results were reported as follows: the eastbound clock had lost 59 ± 10 nanoseconds and the westbound clock increased by 273 ± 7 nanoseconds when compared with the ground level clock.¹⁵²⁵ These results were

¹⁵²³ Clifford Will, “The Confrontation Between Gravitation Theory and Experiment,” *General Relativity: An Einstein Centenary Survey*, ed., Stephen W. Hawking, Cambridge University Press, 1979, p. 62.

¹⁵²⁴ J. C. Hefele and R. E. Keating, “Around-the-world atomic clocks: predicted relativistic time gains,” *Science*, Vol. 177, 1972, pp. 166-168.

¹⁵²⁵ A nanosecond is one thousand millionth (10^{-9}) of a second. As reported by Hefele-Keating, the predicted results were a product of “Gravitational time dilation” (eastward: 144 ± 14 ns; westward: 179 ± 18 ns) and “Kinematic time dilation” (eastward: -184 ± 18 ns; westward: 96 ± 10 ns), producing a “Net effect” prediction of -40 ± 23 ns eastward; and 275 ± 21 ns westward.

released to the world press and treated as just another expected “proof” of Relativity. The truth of what occurred, however, is far different.

First, as in the case of Eddington’s eclipse photographs and the calculations on the perihelion of Mercury, the Hefe-Keating experiment was the victim of an inordinate amount of convenient “adjustments.” Considering the fact that the differences between classical and Relativistic predictions are very slight, tampering with the evidence can easily swing the results in the favor of one side or the other. As such, Hefe and Keating note that they made many “corrections” for the aircraft’s height, direction, speed and latitude. Some of these corrections are based on the so-called “Relativistic” effects associated with an object in motion, and thus the corrections become a case of begging the question.¹⁵²⁶ More egregious is the fact that Hefe and Keating did not use all the data they collected. Louis Essen, world renowned for his work in atomic time-keeping, notes that when all of the Hefe-Keating data is summed up, the values change to 134 nanoseconds (ns) for the westward bound clock and –132ns for the eastward bound clock, approximately a 50% difference in both directions from what was predicted by Relativity. Essen concluded: “I suggest that the theoretical basis of their predictions needs careful scrutiny and that the experimental results given in their paper do not support these predictions.”¹⁵²⁷ Heeding Essen’s words, Alphonsos G. Kelly secured the original documents of the Hefe-Keating experiment from the United States Naval Observatory. Kelly concluded in his abstract:

The original test results were not published by Hefe and Keating in their famous 1972 paper; they published figures that were radically different from the actual test results which are

¹⁵²⁶ Hefe-Keating registered small changes in gravitational field due to changes in altitude above the Earth by using the relativistic time dilation formula of $T = T_0 (1 + gR/c^2)$, where T is the time dilation and T_0 is the “proper time” measured in the rest frame of the event. A planned jet flight of 41.2 hours and average altitude of 8900 meters determines the above predicted figures of “eastward: 144 ns”; whereas the flight westward of 48.6 hours and an average altitude of 9400 meters determines the above predicted figures “westward: 179 ns.” For the Kinematic time dilation, Hefe-Keating used the standard relativistic formula $T = T_0/\sqrt{1-v^2/c^2}$. But because neither the jet nor the Earth’s surface are inertial frames, they use the center of the Earth as the inertial frame and the results are calculated as if the master clock were there. This transposes the above equation to $T_S = T_0 [1 + R^2\omega^2/2c^2]$, where T_S is the time at the surface of the Earth, T_0 is the proper time, R is the Earth’s radius, and ω is the angular velocity of the Earth’s rotation (assuming diurnal motion occurs). For the airborne clock the formula is $T_A = T_0 [1 + (R\omega + v)^2/2c^2]$. Hefe-Keating then note that there is no significant change of R between the Earth’s surface and the jet and thus develop the formula $T_A - T_S = T_0 [2R\omega v + v^2/2c^2]$ and then replace T_0 with $-T_S$ to represent the transition from “Earth center time” to “Earth surface time” to acquire $T_A - T_S = -T_S [2R\omega v + v^2/2c^2]$.

¹⁵²⁷ *Creation Research Society Quarterly*, 14:46, 1977, as cited by Malcolm Bowden, adding: “Essen...said his comments had been submitted to a journal but were rejected.”

here published for the first time. An analysis of the real data shows that no credence can be given to the conclusions of Hefele and Keating.¹⁵²⁸

The errors of the cesium clocks were so numerous that Kelly concluded they simply could not be used to provide reliable data. For example, the clocks were often discovered to be out of synch. Hefele and Keating knew about this problem going into the experiment, since they write:

No two ‘real’ cesium beam clocks keep precisely the same time, even when located together in the laboratory, but generally show systematic rate (or frequency) differences which in extreme cases may amount to time differences as large as 1 second per day.¹⁵²⁹

Kelly concluded the clocks would need to be at least 100 times more accurate to obtain reliable results. This anomaly is compounded by the fact that scholarly texts have consistently quoted the Hefele-Keating experiment as proof of Relativity, and, as of Kelly’s writing, the *Science Citation Index* contained over 1000 references to the 1972 Hefele-Keating experiment. Ironically, Hefele remarks about the anomalies in

¹⁵²⁸ Alphonsos G. Kelly, “Hefele & Keating Tests; Did They Prove Anything?” HDS Energy Ltd, Celbridge, Co. Kildare, Ireland, p. 1, nd.

¹⁵²⁹ As cited in “A New Interpretation of the Hefele-Keating Experiment,” Domina Eberle Spencer and Uma Shama, p. 1, nd. Spencer and Shama add: “Short term fluctuations in rate are caused mainly by shot noise in the beam tubes. Cesium beam clocks also exhibit small but more or less well defined quasi-permanent change in rate.” Kelly adds from the 1970 Winkler, *et al* report: “In a sample of 45 such clocks used at several stations, one failure per six clocks was experienced over two years...During January 1970, three clocks had changed by +16ns, +18ns and –68ns per day. Two others were removed due to poor timekeeping...” (G. M. R. Winkler, R. G. Hall and D. B. Percival, *Meteorologia* 6, No. 4, 126-134, 1970). Beehler’s 1965 report stated that the accuracy of smaller portable clocks [used on the aircraft] is worse, by a factor of two, than large stationary clocks (R. E. Beehler, R. C. Mockler and J. M. Richardson, *Meteorologia* 1, No. 3, 114-131, 1965). Kelly adds:

H & K [Hefele and Keating] claimed that they chose the four clocks because they showed a steady drift rate for at least 24 hours before the tests. It was hoped that they would continue as a steady rate during the tests...Three of the four clocks were so poor in this regard as to render them useless...Clock 120 was a disaster; it had a change from losing 4.50 ns per hour to losing 8.89 ns per hour on the Eastward trip; on the Westward trip it altered from losing 8.88 to losing 4.56 ns per hour. An examination of Table 1 shows that, with the single exception of clock 447, the drift rates were so far from being steady as to render the results totally useless...That erratic clock had contributed all of the alteration in time on the Eastward test and 83% on the Westward test, as given in the 1971 report. Discounting this one totally unreliable clock, the results would have been within 5 ns and 28 ns of zero on the Eastward and Westward tests respectively” (*ibid.*, pp. 2, 3, 6).

their experiment in a 1971 report, but these concerns are not published in the 1972 paper released to the public. Hefele writes:

Most people (myself included) would be reluctant to agree that the time gained by any one of these clocks is indicative of anything...the difference between theory and measurement is disturbing.

More specifically:

Particularly in the case of [clock #] 361 after the eastbound flight, it is quite uncertain what the rate is after the flight...Portable cesium clocks cannot be expected to perform as well under traveling conditions as they do in the laboratory. Our results show that changes as large as 120 nsec/day may occur during trips with clocks that have shown considerably better performance in the laboratory.¹⁵³⁰

Considering the drift rates and fluctuations, Kelly shows that Hefele and Keating's predicted result of -40ns eastward is easily accounted for if the actual flight time of 65.4 hours is divided by a drift rate of merely 0.6ns per hour. Likewise, the predicted result of 275ns westward would be accumulated in actual flight time of 80.3 hours at a slight drift rate of $+3.4\text{ns}$ per hour. But more important is the manner in which Hefele and Keating obfuscated the blatant contradictions in their data. Kelly notes that Hefele and Keating's "corrections" were shocking. For example, for the eastward traveling clock #408, they "corrected" the reading from $+166\text{ns}$ to -55ns ; for the westward traveling clock #361, they "corrected" the reading from -44ns to $+284\text{ns}$; for the westward traveling clock #447 the change was from $+26\text{ns}$ to $+266\text{ns}$, yet their 1972 published paper said "no significant changes in rate were found for clocks 408 and 447 during the westward trip." Kelly remarks: "This barefaced manipulation of the data was outrageous," adding elsewhere:

The trend [of Hefele and Keating's data] was derived from the *average* of the four clocks. The results from the individual clocks was not disclosed; they are published here for the first time...Taking the mathematical average...is meaningless; on the Eastward trip, clock 408 gained 166ns , while the theory forecast a loss of 40ns ; on the Westward trip clock 361 lost 44ns , while the theory forecast a gain of 275ns !¹⁵³¹

¹⁵³⁰ As cited in Kelly's *Hefele and Keating Tests*, p. 3.

¹⁵³¹ Kelly, *Hefele and Keating Tests*, p. 4. Kelly details the results from the trial data that Hefele and Keating did not disclose in their report: Clock #120: lost 196ns , lost 52ns , lost 57ns , gained 413ns , gained 240ns , gained 277ns ; Clock #361: lost 54ns , lost 110ns , lost 74ns , lost 44ns , gained 74ns , gained 284ns ; Clock #408: gained 166ns ,

Kelly notes that Hefele and Keating recognized these unpredicted anomalies and at first tried to compensate for them by taking an average of the drift rates, but, as they said themselves, they soon realized this was a mere rationalization that “depended on the unlikely change that only one rate change occurred during each trip and that this change occurred at the midpoint of the trip.” Astoundingly, Hefele and Keating ignore their own warnings and publish their graphs based upon the very method they themselves had rejected as deficient, and then proceeded to describe them as “convincing qualitative results”! As Kelly notes: “It was published because it looked convincing and not because it gave a legitimate picture of the test results. To the unsuspecting reader, these graphs looked like proof of the success of the tests.” His final remark is: “Only one clock (447) had a fairly steady performance over the whole test period; taking its results gives no difference for the Eastward and the Westward tests.” Not surprisingly, Kelly notes that Hefele and Keating did a similar test a year prior in 1970 and found that there was no discernible time dilation in the cesium clocks. It seems that after obtaining such null results they were determined to find positive results in the following year.¹⁵³²

Essen and Kelly are not the only ones to examine the original data of the Hefele-Keating experiment. Among the more prominent is Domina Spencer, who with Parry Moon, has been critiquing Relativity theory since the 1950s. Spencer’s abstract assures us that, after her analysis of the raw data supplied to her by Dr. Keating:

Thus, one of the essential experimental supports of the relativistic theory of time dilation is shown to be invalid. Instead, the original data provide additional strong support of the reality of the universal time postulate on the velocity of light.¹⁵³³

So not only is the Hefele-Keating experiment non-supportive of Relativity theory, in an ironic twist of fate it has brought us back to the universal time clock of Isaac Newton. In this area Spencer and Moon have done considerable work.¹⁵³⁴ Remarking on the misinterpretations of Hefele and Keating on their own experiment, she writes:

gained 3ns, lost 55ns, gained 101ns, gained 209ns, gained 266ns; Clock #447: lost 97ns, lost 56ns, lost 51ns, gained 26ns, gained 116ns, gained 266ns.

¹⁵³² Kelly, *Hefele and Keating Tests*, p. 7.

¹⁵³³ Domina Eberle Spencer and Uma Shama, *A New Interpretation of the Hefele-Keating Experiment*, p. 1, nd.

¹⁵³⁴ P. Moon, D. E. Spencer, “On the establishment of universal time,” *Phil. Sci.*, Vol. 23, 1956, p. 216; P. Moon, D. E. Spencer and E. E. Moon, “Universal time and the velocity of light,” *Physics Essays*, Vol. 2, 1989, p. 268f; P. Moon and D. E. Spencer,

In order to obtain the time changes predicted by Einstein's theory of relativity, Hefele and Keating do something which is very surprising. They assume that, although the data...are never linear, somehow when the airplane is in motion the curves become linear. And they assume that the slope of this straight line is the average of the data for the 25 hours before the trip. Has the clock a foreknowledge that it is about to travel on an airplane around the world?¹⁵³⁵

All this analysis may be beside the point when we consider the contradiction that is inherent in the actual foundation of the Hefele-Keating experiment. Hefele and Keating claimed to be measuring the time dilation of cesium clocks in motion against a stationary cesium clock at ground level, but the whole basis of Relativity theory is that one cannot determine, or even regard, one location as being at rest while the other is in motion. This objection was clearly denounced in a comprehensive critique written by W. A. Scott Murray.¹⁵³⁶ Hefele and Keating seem to have anticipated the objection and thus try to circumvent it by stating:

Because the Earth rotates, standard clocks distributed at rest on the surface are not suitable in this case as candidates for coordinate clocks of an inertial space. Nevertheless, the relative timekeeping behavior of terrestrial clocks can be evaluated by reference to hypothetical coordinate clocks of an underlying nonrotating inertial space.

Yet they proceed to admit that:

It is important to emphasize that special relativity purports to describe certain physical phenomena only relative to (or from the point of view of) inertial systems, and the speed of a clock relative to one of these systems determines its timekeeping behavior.¹⁵³⁷

"Binary stars and the velocity of light," *Journal of the Optical Society of America*, Vol. 43, 1953, p. 635f; P. Moon, D. E. Spencer and E. E. Moon, "The Michelson-Gale experiment and its effect on the postulates of the velocity of light," *Physics Essays*, Vol. 3, 1990, p. 431f; P. Moon, D. E. Spencer and U. Y. Shama, "The Sagnac effect and the postulates on the velocity of light," *Physics Essays*, Vol. 4, 1991, p. 249f; D. E. Spencer and U. Y. Shama, "Stellar Aberration and the Postulates of the Velocity of Light," *Physics Essays*, 1996.

¹⁵³⁵ Domina Spencer, "A New Interpretation of the Hefele-Keating Experiment," p. 2.

¹⁵³⁶ W. A. Scott Murray, "If you want to know the time..." *Wireless World*, December, 1986, pp. 28-31.

¹⁵³⁷ J. C. Hefele and R. E. Keating, "Around-the-world atomic clocks: predicted relativistic time gains," *Science*, Vol. 177, 1972, pp. 166-168. W. A. Scott Murray

The fact is, however, that there is no inertial system from which Hefele and Keating can measure their so-called time dilation, unless, of course, they are willing to adopt a motionless Earth as the base for their ground clock. Of course, if they admit the Earth is motionless it makes experiments designed to prove Relativity an exercise in futility.

develops this line of critique in “If you want to know the time...” *Wireless World*, December 1986, vol. 92, n 1610, 28-31.

Appendix 7

Does the Global Positioning System Prove General Relativity?

The Global Positioning System (GPS), although invaluable in providing us with a very precise navigation system is, nevertheless, understood by science to be a large-scale version of Sagnac's rotating interferometer, and thus a thorn in the side of Relativity theory. This was proven in 1984 when GPS technician D. W. Allan and a team of international scientists measured the same effect on light as Sagnac did in 1913.¹⁵³⁸ In this instance the Global Positioning Satellites, whose distance above Earth is approximately 24,000 km (app. 14,900 miles), replaced Sagnac's rotating interferometer. The Earth and the satellites act as a giant interferometer, so to speak. When an electromagnetic signal is sent from the ground station to the GPS, the signal takes 0.08000 seconds to arrive. However, since the GPS is rotating around Earth, some of the signals sent from the ground will arrive either at an approaching or a receding GPS satellite. Allan and his colleagues found that microwave beams sent to an approaching GPS satellite take 50 nanoseconds less time to reach the satellite than beams sent to a receding satellite. The 50-nanosecond difference in travel time of light would equal, proportionately, the 0.05-1.0 fringe shift in the 1913 Sagnac experiment. Once again, we have confirmation that the speed of light is not the same for all observers. Unfortunately, these facts are not advertised either by the Relativists or GPS mechanics. Rather, the 50-nanosecond difference is now automatically built into the computer programs for the GPS, and no one knows the difference. Some physicists have never even heard of the Sagnac effect, let alone studied its implications.

In any case, each GPS unit must, without exception, take into account the Sagnac effect (that it takes a light beam longer to travel the same distance in a rotating device than a light beam going in the opposite direction of the same rotating device) in order for the GPS to keep accurate time and determine proper coordinates on Earth. To keep the GPS within a meter of determining a designated location on Earth, the GPS clock must be accurate to within 4 nanoseconds, which requires a time stability ratio on the order of $1:10^{13}$, and thus atomic clocks are employed for this purpose (e.g., Cesium clocks). Even then, the GPS requires frequent uploads of "clock corrections" to keep everything in synch. When the clocks are in synch, still, it is an inevitable occurrence that GPS signals directed to an approaching ground station arrive at least

¹⁵³⁸ D. W. Allan, D. D. Davis, M. Weiss, A. Clements, B. Guinot, M. Granveaud, K. Dorenwendt, B. Fischer, P. Hetzel, S. Aoki, M. K. Fujimoto, L. Charron, and N. Ashby, "Accuracy of International Time and Frequency Comparisons Via Global Positioning System Satellites in Common-View," *IEEE Transactions on Instrumentation and Measurement*, IM-34, No. 2, 118-125, 1985. (BIN: 689); Also cited in *Science*, 228: 69-70, 1985.

50 nanoseconds prior to signals sent to a receding ground station. Even when making adjustments for the Doppler effect and gravitation redshift, there still remains a margin of error due to the Sagnac effect. If these factors are not taken into account, a GPS could be off by as much as 11 km (6.8 miles) in one day. Relativists, since they assume that the theory of Relativity is correct, explain these differences by claiming they are due to “relativistic” effects (e.g., “time dilation”) upon light moving in a non-inertial frame. This is precisely the explanation that D. W. Allan proposed in 1984. This explanation, of course, is simply begging the question, since one cannot use as proof that which he has not first proven. In any case, here is how one Relativist explains his methodology:

...the simplest approach is to use an approximate solution of the [General Relativity] field equations in which Earth’s mass gives rise to small corrections to the simple Minkowski metric of Special Relativity, and to choose coordinate axes originating at the planet’s center of mass and pointing toward fixed stars. In this Earth-centered inertial reference frame (ECI), one can safely ignore relativistic effects due to Thomas precession or Lense-Thirring drag. The gravitational effects on clock frequency, in this frame, are due to Earth’s mass and its multipole moments.¹⁵³⁹

One wonders, with the assortment of intersecting theories described above, why the author thinks this is “the simplest approach.” Be that as it may, we notice that his proposed solution not only appeals to remedies that are themselves imprecise (e.g., “approximate solution of [GTR] field equations”) or speculative (“Minkowski metric of Special Relativity,” or “Lense-Thirring drag”), but he shows his dependence on an “Earth-centered” inertial frame in order to allow his “relativistic” theories to explain how the GPS functions. The author confirms his objective in another paragraph:

...the leading contribution to the gravitational potential Φ is the simply Newtonian term $-GM_E/r$. The picture is Earth-centered, and it neglects the presence of other Solar System bodies such as the Moon and the Sun. That they can be neglected by an observer sufficiently close to Earth is a manifestation of general relativity’s equivalence principle. In the ECI frame, the only detectable effects of distant masses are their residual tidal potentials.¹⁵⁴⁰

¹⁵³⁹ Neil Ashby, “Relativity and the Global Positioning System,” *Physics Today*, May 2002, p. 3.

¹⁵⁴⁰ *Ibid.*, p. 4. It is also interesting that Ashby’s footnote on the “equivalence principle” cites “N. Ashby, B. Bertotti, *Physical Review D* 34, 2246 (1986)” as supporting documentation for the principle, yet Bertotti is well-known in geocentric circles as

We notice here that the goal is to obtain an “Earth-centered” inertial frame, and thus he uses Newtonian formulas rather than Relativistic formulas since the latter are much more complicated. So far, the GPS technician has shown that he is partial to a geocentric map, but allows himself the prerogative of translating Earth-centered mechanics into a Relativistic framework to explain the same effects from a non-centered, non-inertial Earth frame. The reason he must do so is that it is next to impossible to make accurate measurements when the objects one is trying to measure keep moving, as the Earth does around the sun in the heliocentric system. Moreover, without giving his reader any details, the technician also allows himself to justify his use of a geocentric frame by employing the same “detectable effects of distant masses” and their “tidal potentials” from the sphere of stars surrounding Earth as geocentric scientists do. In other words, many geocentrists hold that the forces we experience on Earth (e.g., gravitational tidal effects, centrifugal, Coriolis and Euhler forces, etc.) are due to the rotation of billions of stars around the Earth as they distribute their enormous gravitational effects and angular momentum.¹⁵⁴¹ In fact, in Ashby’s reference to “general relativity’s equivalence principle,” it is conceded by Relativists that a fixed-Earth around which the stars rotate (e.g., geocentrism) is precisely “equivalent” to a fixed-star system and a rotating Earth (e.g., heliocentrism). Thus, Ashby would have to admit that the “fixed stars” to which he referred in the above opening paragraph would not be fixed in an “Earth-centered inertial” frame since, if Earth is in the inertial position, the stars must be moving against that inertia.

The author reinforces our analysis of his methodology in another revealing paragraph:

Computations of satellite orbits, signal paths, and relativistic effects appear to be most convenient in an ECI frame. But navigation must generally be done relative to the Earth’s surface. So GPS navigation messages must allow users to

providing one of the best mathematical models of a geocentric universe, which was published nine years before Ashby wrote the above article with Bertotti (Barbour and Bertotti, *Il Nuovo Cimento* B, 38:1, 1977). In this mathematical treatise, Barbour and Bertotti employ Machian physics to show the equivalence of the heliocentric system and a geocentric system. See the further treatment of Barbour and Bertotti in Chapter 10.

¹⁵⁴¹ Heliocentrists are quite aware of this “enormous” force of gravity, since they hold that the sun is held in its 300 km/sec orbit by the gravity at the center of the Milky Way, and the Milky Way itself is moving at a clip of 600 km/sec because it is being pulled by gravity toward the constellation Orion, and such is the case for all the galaxies and various other objects in the universe – all are caused to move by gravity, and a gravity which propagates instantaneously (something Relativity has yet to answer).

compute the satellite positions in a fixed-Earth, rotating coordinate system, the so-called WGS-84 reference frame.¹⁵⁴²

In other words, navigators working on the surface would find it difficult to keep track of satellites moving against an inertial Earth because the satellite's positions would constantly be shifting as the satellite orbited the Earth. Thus, the WGS-84 coordinate system was invented. This system makes it appear as if the satellites are moving precisely the same speed as the Earth's rotation. In other words, the WGS-84 (World Geodetic System of 1984)¹⁵⁴³ is the "coordinate system" which is fixed to the Earth. Thus, one could say that the satellites are moving in a one-to-one correspondence with the Earth's rotation, or, from the geocentric perspective, one can say that the Earth and the satellites are motionless. Ashby then explains the WGS-84 reference frame more specifically:

The navigation messages provide fictitious orbital elements from which a user can calculate the satellite's position in the

¹⁵⁴² *Ibid.*, p. 5. Related to this is Gerardus Bouw's observation of the history of satellite operation: "Now some will argue that since the satellites sent up by NASA use heliocentrically-derived equations, that our space program is a testimony to the success of heliocentrism; but this erroneously assumes that the geocentrically derived equations would be different. Such has been shown not to be the truth. The equations of motion are identical in both models. At least a half-dozen scientific papers since 1916 have shown that to be the case. The only differences between the two models are philosophical and theological" (*Bulletin of the Tychonian Society*, No. 46, 1988, p. 32)

¹⁵⁴³ WGS84 is an "Earth-Centered, Earth-Fixed" (ECEF) Cartesian coordinate system. Satellite coordinates are computed relative to the ECEF. The Cartesian coordinates consist of the x-axis extending from the center of the Earth outward through the intersection of the equator and the Prime Meridian (longitude = 0°), and z-axis outward along the Earth's spin axis - through the north and south poles. The y-axis is orthogonal (perpendicular) to both x-axis and z-axis. The entire coordinate system rotates with the Earth, and is thus, "Earth-fixed." Satellite positions (and predicted positions) are determined in ECEF time-position quadruples: (x, y, z, t), i.e., x-y-z ECEF coordinates, a function of time. The four defining parameters of the WGS84 ellipsoid are: Semi-major axis (a): 6378137m. Ellipsoid flattening (f): 1/298.257223563 (derived from the value of the normalized second degree zonal harmonic coefficient of the gravitational field: $-484.16685 \times 10^{-6}$). Angular velocity of the Earth (ω): 7292115×10^{-11} rad/sec. The Earth's gravitational constant (atmosphere included) (GM): 3986005×10^{-8} m³/sec². GPS receivers receive the transmission time from each satellite using the synchronization capabilities of each message signal. The receiver then records the time the signal was received and, based on the travel time at the speed of light, the distance traveled between the satellite and the GPS receiver is determined. Given 4 satellites in view of a GPS receiver of unknown location, 4 ranges are explicitly known via the timing of the transmitted messages. As before, satellite vehicle x, y, and z coordinates in ECEF-space are known through the satellite ephemeris messages transmitted by each satellite. After unknown position coordinates are determined in the ECEF reference, a coordinate rotation matrix rotates each of the ECEF-matrix row vectors into local coordinates, i.e., latitude, longitude, and elevation with respect to the WGS-84 datum.

rotating WGS-84 frame at the instant of its signal transmission. But this creates some subtle conceptual problems that must be carefully sorted out...For example, the principle of the constancy of c [speed of light] cannot be applied in a rotating reference frame, where the paths of light rays are not straight; they spiral.¹⁵⁴⁴

But the orbits are “fictitious” because the satellites are not really going the same speed as the Earth’s supposed rotation. Along the way, the author has admitted one of the anomalies of Relativity theory, that is, that the speed of light is not constant in a rotating frame of reference. This is one of the facts that the 1913 Sagnac experiment demonstrated, but the author doesn’t seem bothered by the fact that he has no explanation why the constancy of light does not hold up in such cases, except to say that light has a problem staying at c when it is required to move in curved paths. Interestingly enough, in his famous 1905 paper, Einstein had attempted to apply his Special Theory of Relativity to systems in rotation, as he did, for example, when he compared a clock at the North Pole with a clock circling the equator. But his Special Relativity couldn’t explain how light moved in rotating systems, so the General Relativity theory was adopted in order to answer Sagnac’s rotating interferometer experiment. Since General Relativity incorporates the remaining universe, the Relativist could now appeal to the “distant rotating masses” (i.e., the “fixed” stars which suddenly were not so “fixed”) that produce “counter-rotation effects” upon Earth. This explanation, if one recalls, is the same one that Ashby proposed as an explanation for an “Earth-centered inertial” system in “general relativity’s equivalence principle” in which the “detectable effects of distant masses are their residual tidal potentials.”

The author now gets to the heart of the matter regarding the Sagnac effect:

One of the most confusing relativistic effects – the Sagnac effect – appears in rotating reference frames. The Sagnac effect is the basis of ring-laser gyroscopes now commonly used in aircraft navigation. In the GPS, the Sagnac effect can produce discrepancies amounting to hundreds of nanoseconds.¹⁵⁴⁵

It is only “confusing” to Relativists because they can’t explain Sagnac’s effects without resorting to obtuse tensor calculus and the invoking of “conditions” they have no way of proving true, except by circular reasoning. In other words, they have no physical explanation for why one beam in Sagnac’s interferometer traveled slower than the other

¹⁵⁴⁴ *Ibid.*, p. 5.

¹⁵⁴⁵ *Ibid.*, p. 5.

beam; rather, they only account for Sagnac's effect (and they must or else their GPS satellites will be off by "hundreds of nanoseconds") by creating a "relativistic" mathematical equation. But mathematical equations explain very little about the causes for a particular phenomenon. Equations only make one side equal to the other, but with integers on either side that do not necessarily represent the physical processes taking place.

In regard to the "fixed-earth" concept, the author reminds his readers that:

Observers in the non-rotating ECI inertial frame would not see a Sagnac effect. Instead, they would see that receivers are moving while a signal is propagating. Receivers at rest are moving quite rapidly (465 m/s at the equator) through the ECI frame. Correcting for the Sagnac effect in the Earth-fixed frame is equivalent to correcting for such receiver motion in the ECI frame.¹⁵⁴⁶

Here the author is admitting that if the system is not rotating, there would be no Sagnac effect, yet it would appear as another effect (i.e., "receiver motion"). He still hasn't explained why a Sagnac effect exists in a rotating system (except to point out the anomaly of Relativity theory that light doesn't behave the same when it is not moving in straight lines). What he has failed to consider is that these anomalies are not "relativistic" effects, but *physical* effects caused by the medium through which light must travel, the very thing that Sagnac demonstrated by his 1913 experiment. Sagnac's experiment did not prove "time dilation" or "rotational effects" but, through a device showing that when light came up against a medium or a force that impeded its speed and made it arrive at the destination in more time than expected, it demonstrated none other than the presence of absolute motion in a space that was hitherto called "relativistic" by Einstein. Answering this by appealing to "time dilation" is merely an attempt to paint the phenomenon by the phenomenon itself, which doesn't explain anything, except one's biased perceptions.

Two experts in the field of GPS mechanics answer Ashby's claims by an even more acute interpretation of the Sagnac experiment. Wang and Hatch state that:

The simplest interpretation of the result [of the Sagnac experiment] is that the speed of light remains constant relative to the center of rotation and, thus, not of constant speed relative to the rotating detector. Special Relativity (SRT) claims the Sagnac effect is due to the rotation. Since rotation is not relative, the Sagnac effect can be due to non-isotropic light

¹⁵⁴⁶ *Ibid.*, p. 6.

speed and still be consistent with Special Relativity. The effect of the movement of the receiver during the transit time of a GPS signal is referred to in the GPS system as the one-way Sagnac effect. However, it is not at all evident that the Sagnac effect is due to rotation...the Sagnac effect exists not only in circular motion, but also in translational motion.¹⁵⁴⁷

Following this, the authors answer some of the more outlandish of Ashby's claims. Of the three, the one that is directly related to the geocentric question is the last. Ashby claims the following: "Of course if one works entirely in the nonrotating ECI frame there is no Sagnac effect." Wang and Hatch answer as follows:

We have even more convincing data that Ashby's claim is false. NavCom Technology, Inc. has licensed software developed by the Jet Propulsion Lab (JPL) which, because of historical reasons, does the entire computation in the ECI frame. Because of some discrepancies between our standard earth-centered earth-fixed solution results and the JPL results, we investigated the input parameters to the solution very carefully. The measured and theoretical ranges computed in the two different frames agreed precisely, indicating that the Sagnac correction had been applied in each frame.

As the discussion of the Sagnac effect indicates the fundamental question regarding the speed of light is the following: Is the speed of light constant with respect to the observer (receiver) or is it constant with respect to the chosen inertial ECI frame? Clearly the GPS range equation indicates the speed of light is constant with respect to the chosen frame...The JPL equations, used to track signals from interplanetary space probes, verify that the speed of light is with respect to the chosen frame. In the JPL equations, the chosen frame is the solar system barycentric frame...Clearly, the JPL equations treat the speed of light as constant with respect to the frame – not as constant with respect to the receivers.¹⁵⁴⁸

In other words, the Jet Propulsion Laboratory employs the Earth Centered Inertial frame (ECI) for probes sent out near the Earth (as does NASA and the GPS), yet they claim to use the "solar system barycentric

¹⁵⁴⁷ Ruyong Wang and Ronald R. Hatch, *Conducting a Crucial Experiment of the Constancy of the Speed of Light Using GPS*, ION GPS 58th Annual Meeting / CIGTF 21st Guidance Test Symposium, 2002, p. 500.

¹⁵⁴⁸ Ruyong Wang and Ronald R. Hatch, *Conducting a Crucial Experiment of the Constancy of the Speed of Light Using GPS*, ION GPS 58th Annual Meeting / CIGTF 21st Guidance Test Symposium, 2002, p. 500.

frame” for deep space navigation. But Wang and Hatch tell us: “the Jet Propulsion Lab...because of historical reasons, does the entire computation in the ECI frame.” So, not only does the Jet Propulsion Lab use the ECI frame exclusively, Wang and Hatch tell us that the Lab corrects the calculations in its “solar system barycentric frame” so that they match the ECI frame! In other words, the ECI frame is the standard, and thus, use of the solar system barycentric frame is superfluous. Once the Lab’s computer makes the corrections to the solar system barycentric frame, in reality the deep space navigation is actually using the ECI frame – a fixed Earth. The public wouldn’t have been made privy to this sleight-of-hand manipulation except for the fact that two knowledgeable insiders, Wang and Hatch, have told the real story. In effect, the Earth Centered Inertial frame (e.g., geocentrism) is the only frame that will allow the GPS and various space probes to work properly.

Ashby later writes:

The Sagnac effect also occurs if an atomic clock is moved slowly from one reference station on the ground to another. For a slow clock transport, the effect can be viewed in the ECI frame as arising from a difference between the time dilation of the portable clock and that of a reference clock whose motion is solely due to Earth’s rotation. Observers at rest on the ground, seeing these same asymmetric effects, attribute them instead to gravitomagnetic effects – that is to say, the warping of spacetime due to spacetime terms in the general-relativistic metric tensor. Such terms arise when one transforms the invariant ds^2 from a nonrotating reference frame to a rotating frame.¹⁵⁴⁹

¹⁵⁴⁹ *Ibid.*, p. 6. To counter this, Van Flandern cites the phenomenon wherein a high-altitude GPS clock runs 46,000 nanoseconds faster per day than a clock at ground level. He attributes this difference not to Relativistic effects, but to the fact that the gravitational field is weaker at high altitudes, and thus the atom exchange in atomic clocks have less gravity against which they must travel, and therefore run faster. However, since the GPS clocks are orbiting the Earth at about 3 kilometers per second, they pass laterally through the gravitational field, and thus tick 7,000 nanoseconds slower than stationary clocks. The difference between 46,000 and 7,000 is 39,000 nanoseconds. To offset this figure, engineers reset the GPS clock rates, decreasing them before launch date to 39,000 nanoseconds per day. In this way they can tick at the same rate as the ground clocks, and it can be claimed that the system “works.” Van Flandern points out, however, if one uses Einstein’s theory, then one would expect that, since the clocks all move very rapidly and with varying speeds relative to the observer on Earth against which the true speed is measured, relativistic corrections would have to be made on a continual basis, and thus render the GPS non-functional. As it turns out, no such corrections are needed after the GPS are launched. Van Flandern concludes: “They have basically blown off Einstein” (Tom Bethel, “Rethinking Relativity,” *The American Spectator*, April 1999). Others, such as Neil Ashby, refute this by reminding critics that, because the GPS have eccentric orbits, they have frequency variations due to varying speeds and heights, which then require a “relativistic” correction (letter on file, Feb. 21, 2005). But Van Flandern’s remark is not concerned with “corrections” but with the overall wiring, as it were, of the GPS in ideal conditions.

The Sagnac effect is particularly important when GPS signals are used to compare times of primary reference cesium clocks at national standards laboratories far from each other....A Sagnac correction is needed to account for the diurnal motion of each receiver during signal propagation. In fact, one can use the GPS to observe the Sagnac effect. Of course, if one works entirely in the nonrotating ECI frame, there is no Sagnac effect.¹⁵⁵⁰

Generally, however, the transmissions arrive at different times. The navigation messages then let the receiver compute the position of each transmission event in the Earth-fixed WGS-84 frame. Before equations can be solved to find the receiver's location, the satellite positions must be transformed to a common Earth-centered inertial frame, since light propagates in a straight line only in an inertial frame.¹⁵⁵¹

Here we see the reality of absolute space is such a constituent fabric of the universe that the Sagnac effect even occurs in the inner recesses of atoms. Of course, the Relativist chalks this up to “the warping of spacetime” because he simply has no *physical* explanation for what is occurring, so he is forced to change space and time by means of mathematics to mask the physical effects. What he misses is that, if the Sagnac effect is produced in something as small as atoms, then something even smaller is colliding with those atoms, and this is the same reason that Michelson and others had always measured a small positive result in the interferometer experiments. The positive result, as we have seen over and over again, was small enough to escape being explained by the translational motion of the Earth, but large enough to indicate that there was indeed an Earth in the midst of a moving universal medium. The Earth remained in the center of the medium the same as a ship anchored at sea in the eye of a hurricane. This is the position which does not have to appeal to “fixed-Earth” frames merely for “convenience,” but because it is, indeed, the state of affairs in the universe. Ashby continues:

The receiver must then keep track of its own motion during this receiving interval and make appropriate corrections. These corrections are again proportional to $1/c^2$, that is to say, they are also relativistic....Historically, there has been much confusion about properly accounting for relativistic effects....In the special case of two inertial frames in relative

¹⁵⁵⁰ *Ibid.*, p. 6.

¹⁵⁵¹ *Ibid.*, p. 8.

uniform motion, these are the familiar Lorentz transformations.¹⁵⁵²

Relativistic coordinate time is deeply embedded in the GPS. Millions of receivers have software that applies relativistic corrections. Orbiting GPS clocks have been modified to more closely realize coordinate time. Ordinary users of the GPS, through they may not need to be aware of it, have thus become dependent on Einstein's conception of space and time.¹⁵⁵³

So, once again, we see the convenient "Lorentz transformations," the invention of the late nineteenth century specifically for the purpose of avoiding (borrowing GPS terminology) the "Earth-centered, Earth-fixed" implications of the Michelson-Morley experiment. As we noted earlier, they have already pre-programmed the GPS to account for the 50-nanosecond differential and no one is the wiser.

But it is the author's last statement that is even more troublesome. In reality, the only reason people have become "dependent on Einstein's conception of space and time" is that the modern science establishment will entertain no other answers to the Sagnac effect than the tensor calculus and non-Euclidean geometry of General Relativity theory. Even though it is only a theory, it has entrenched itself as the *sine qua non* of the world of physics, and its relativism has seeped deep into the psyche of man. It purports to have been verified by experiment, but the experiments, as one can easily see by reading Ashby's description of the GPS, are merely self-serving opportunities to interpret things as "relativistic." It is uncanny how Relativists have literally stolen experimental facts, which were originally understood and accepted as disproving Relativity and, by a wave of their mathematical wand, they turn them into proofs for the same. In actuality, it is Relativity that avoids the real implications of the Sagnac effect, yet it has the temerity to steal an "Earth-centered, Earth-fixed coordinate system" from geocentrism in order to make its GPS navigable. Life certainly is ironic.

¹⁵⁵² *Ibid.*, p. 8.

¹⁵⁵³ *Ibid.*, p. 10.

Appendix 8

The de Broglie Wavelength

In 1923, A. H. Compton performed an experiment shooting high frequency X-rays at various materials. He found that, after the X-ray bounced off the object, it had a slightly longer wavelength than the incident X-ray, which means it had lower energy. It also meant that the energy of the X-ray was partially being transferred to the material it hit (usually graphite). The exchange between the X-ray and the graphite followed the known laws of conservation of momentum and energy. The whole process is known as the Compton Effect, and it supported the idea that energy traveled in very tiny but independent packets. The packets were called photons and they were considered as particles.

Later in 1923, Louis de Broglie proposed that the aforementioned particles also consisted of, and traveled in, waves. He was not sure himself precisely what this meant, since it was the result of the mathematical calculations he derived from experiments left to him by previous scientists studying the nature of the atom, specifically Neils Bohr, who published his work about ten years earlier. Bohr understood the atom as consisting of electrons orbiting a nucleus of protons and neutrons. Bohr said that the electrons could orbit only at defined energy levels but at no place in between those levels. As the electrons orbit the nucleus, they naturally possess angular momentum (the phenomenon responsible for the behavior of an ice skater who spins faster as she brings her arms in close to her body). Knowing the angular momentum, one could then calculate the electron's speed, orbital radius, and kinetic and potential energy for each specific orbit.

The electrons are free to move from one level to another, however. If they move to a lower energy orbit, they will release energy; if they move to a higher energy orbit, they will absorb energy. The amount of energy will equal the energy difference between the orbits. Hence, for illustration purposes only, if the energy of orbit level 1 is 10, and that of orbit level 2 is 20, the photon that is released or absorbed will possess an energy of 10.

About two decades earlier, Max Planck determined that energy comes in precise amounts. For example, molecules (groups of atoms) vibrate at certain frequencies but cannot vibrate at intermediate frequencies. Planck stumbled onto the smallest numerical difference between the various frequencies, and it was assigned a value of 6.626×10^{-34} joule-seconds, which is represented by the symbol h . (A joule is the standard unit of energy which is attained by measuring the angular momentum, or spin energy, of a rotating or vibrating object.) The energy of the molecule is thus determined by its frequency of vibration multiplied by h .

Einstein, after the famous photoelectric experiments of 1905 (wherein he directed light beams onto metal surfaces and found that a certain amount of light energy caused a specific number of the metal's electrons to be released), then proposed that the energy in light can only exist in certain values. The smallest unit of light energy was called a photon. As the light hit the metal plate, one photon of light would release one electron from the metal plate. The energy value of a photon would be its frequency (vibrational energy) multiplied by Planck's constant, h . In this model, photons are understood as particles.

In other experiments, however (such as the double-slit experiments we will address next in "Are There Universal Connections in Space?"), light behaves also as a wave. A wave has no substance of its own, but is merely a periodic motion of the medium in which it travels. (For example, one creates a wave by applying an up-and-down motion to a whip. The wave has energy, for unless one holds onto the handle of the whip, it will be forcefully dislodged from one's hand.) However, a question left unresolved is: if light is a wave what is its medium? To this day, modern science does not know for certain whether light is a particle or a wave, a combination of the two, or perhaps neither and thus something altogether undiscovered. This undefined state is the reason why light is sometimes referred to as an "electromagnetic wave" and at other times as "photons." As Einstein himself said in the midst of his career: "For the rest of my life I want to reflect on what light is,"¹⁵⁵⁴ or as he told his best friend, Michele Besso, regarding the nature of light quanta: "Nowadays every Tom, Dick and Harry thinks he knows it, but he is mistaken."¹⁵⁵⁵ Sir William Bragg, director of the Royal Institute, joked in 1927: "On Mondays, Wednesdays, and Fridays we teach the wave theory and on Tuesdays, Thursdays, and Saturdays the corpuscular theory."¹⁵⁵⁶

Not only was light a puzzle, Louis de Broglie, not satisfied with the simple fact that electrons possess angular momentum or that they discharge or absorb energy as they jump into different orbits, wanted to find out the reason for this behavior. He proposed that electrons, and all matter, were not merely particles but also consisted of waves. Theoretically, everything from electrons to baseballs and beyond had a "wavelength" (λ), which could be measured by using Planck's constant, (h), divided by the object's momentum (p) in the equation $\lambda = h/p$. A big object, such as a pitched baseball, does not show a wavelength since its momentum multiplied by Planck's constant (6.626×10^{-34}) would yield a wavelength of less than 10^{-25} nanometers in size. That is twenty-four orders smaller than the diameter of an atom.

¹⁵⁵⁴ *Einstein: The Life and Times*, p. 252. The original German is: "Für den Rest meines Lebens möchte ich darüber nachdenken, was Licht ist."

¹⁵⁵⁵ *The Private Lives of Albert Einstein*, p. 105.

¹⁵⁵⁶ *Einstein: The Life and Times*, p. 420.

But if electrons are waves, then the idea of a particle whizzing around the nucleus had to be modified. The electron's relation to the nucleus was now understood as a wave filling the sphere of the atom. As waves, they won't discharge or absorb photons unless they change their energy level, which means they change their wavelength, not their orbit. As in light waves, increasing the wavelength causes the frequency of the wave to decrease, and thus lowers the energy level of the electron, which in turn releases a photon. The opposite occurs when the wavelength is shortened.

Erwin Schrödinger developed the model by employing more advanced equations. He concluded that electrons do not revolve around the nucleus at all; rather, the waves are stationary. Schrödinger's atom, like Bohr's, was electrical in nature, but the electric charge, rather than being contained in rotating electrons, is distributed throughout the entire atom. The electric charge may fluctuate and thus emit photons, or it may emit electrons, which in this case are considered as little bunches or "quanta" of electric charge split off from the main body of the atom, similar to flames coming off a burning log. To calculate the electrical energy, electrons were considered in terms of energy levels of stationary waves rather than particles circling the nucleus. The wavelengths for these atoms and electrons could be determined by the use of a mathematical system called "matrix mechanics" or Quantum Mechanics, but this was a purely mathematical explanation of the atom that had little if any pictorial description available.¹⁵⁵⁷ Moreover, the Schrödinger atom requires a universal medium, since the atom itself has no definite boundary but theoretically extends into infinity, and thus all atoms are mysteriously united. As such, Schrödinger's model advanced the idea of a universal electric plenum, which would then be enhanced by the work of Paul Dirac. After some development of the model, in 1951 Dirac concluded:

We have now the velocity at all points of space-time, playing a fundamental part in electrodynamics. It is natural to regard it as the velocity of some real physical thing. Thus with the new

¹⁵⁵⁷ Interestingly enough, in light of the DeBroglie-Schrödinger theory, G. Bouw has proposed the following: "If the quantum law holds for the universe as a whole, we can imagine the universe to be a standing wave of wavelength (diameter) $\lambda = 4 \times 10^{28}$ cm (36 billion light years). Using Compton's formula $\lambda = h/mc$ where λ is the wavelength, h is Planck's constant, m is the effective mass of the particle, and c is the speed of light, we derive the effective mass of the universe as 5.5×10^{-66} gm, much much lighter than any known particle, photon or neutrino. That mass is only perceived at the edge of the universe. Any place else, even at the dynamic center which is, of course, the position of the Earth, perceived the mass of the universe to be 5.68×10^{56} gm" (*The Biblical Astronomer*, vol. 12, no. 99, 2002, pp. 15-16).

theory of electrodynamics we are rather forced to have an ether.¹⁵⁵⁸

¹⁵⁵⁸ *Nature* (London): 168: 906-907 (1951), as cited in *The Einstein Myth*, p. 102. Along with Dirac, in 1959 Louis de Broglie also began to reconsider the ether hypothesis. Later, Stark, Arrhenius, Lenard, Yukawa and Soddy began similar investigations.

Appendix 9

The Personal Lives of: Copernicus, Galileo, Kepler, Newton and Einstein

In Chapter 2 we detailed the fraud and deception that often occurs in the scientific community. In addition to those revelations are the historical facts, often suppressed, concerning the personal lives of the world's renowned scientists. Their rejection of God and revelation are not in a vacuum. As we have seen from Gould to Sagan to Crick, their materialistic conclusions concerning the origins and function of the cosmos invariably affect the kind of lives they lead, and their biographies are often a sordid tale of pride and immorality. After forcefully releasing themselves from the motherly hand of the Church, scientists subsequently made themselves into icons of intellect and stamina that were bigger than life; 'men of renown' who took on an almost god-like quality, similar to the 'giants' who lived just prior to the Great Flood, and who also became the epitome of corruption and were eventually destroyed (Genesis 6:4-5). Interestingly enough, one scientist writing about Albert Einstein inscribed the words: "THERE WERE GIANTS IN THE EARTH IN THOSE DAYS" in the opening pages of his book.¹⁵⁵⁹ The reality is, although these scientists are consistently revered in textbooks as the titans of humanity, history often tells quite a different story. In addition to the problems and anomalies in current science, the moral integrity of those who vied for its advancement was often at odds with convention, even by today's standards. We will limit our survey to just the prominent names associated with current Copernican cosmology (Copernicus, Kepler, Galileo, Newton and Einstein).

Nicolaus Copernicus

Copernicus' personal life is not as well known as that of others who followed him, but we do know several disturbing things about him. In 1509, Copernicus published a translation of the obscenity-filled letters of the Byzantine poet, Simoncatta. Further sexual exploits came to light when it was discovered that Copernicus kept a mistress, but he refused to dismiss her when confronted by his diocesan bishop. Georg Joachim Rheticus, with whom Copernicus kept company and who was his public relations man, was a homosexual and often found himself being run out of town on numerous occasions. Ultimately, Copernicus double-crossed him, an event that eventually led Rheticus to sever ties with him completely.¹⁵⁶⁰

¹⁵⁵⁹ Donald W. Rogers, *Einstein's Other Theory*, New Jersey, Princeton University Press, 2005.

In regard to his heliocentric theory, Copernicus consistently appealed to the “harmony” of his system, but it was a harmony ennobled by a sun that he personified, and, some say, deified. Copernicus writes:

In the middle of all sits Sun enthroned. In this most beautiful temple could we place this luminary in any better position from which he can illuminate the whole at once? He is rightly called the Lamp, the Mind, the Ruler of the Universe: Hermes Trismegistus names him the Visible God, Sophocles’ Electra calls him the All-seeing. So the Sun sits as upon a royal throne ruling his children the planets which circle round him. The Earth has the Moon at her service. As Aristotle says, in his *On Animals*, the Moon has the closest relationship with the Earth. Meanwhile the Earth conceives by the Sun, and becomes pregnant with an annual rebirth.¹⁵⁶¹

Karl Popper shows the origin of these cultic ideas:

Copernicus studied in Bologna under the Platonist Novara; and Copernicus’ idea of placing the sun rather than the Earth in the center of the universe was not the result of new observations but of a *new interpretation* of old and well-known facts in the light of semi-religious Platonic and Neo-Platonic ideas. The crucial idea can be traced back to the sixth book of Plato’s *Republic*, where we can read that the sun plays the same role in the realm of visible things as does the idea of the good in the

¹⁵⁶⁰ Koestler notes: “Rheticus was a sodomite” (*The Sleepwalkers*, p. 179, see also pp. 170f, 184f). Gingerich adds: “There were dark rumors of a drunken homosexual episode involving a student half his age. The irate father of the young man involved brought a lawsuit. In disgrace, Rheticus fled from Leipzig” (*The Book that Nobody Read*, p. 182). Rheticus was also convinced of the Copernican system. He writes: “...each of the planets, by its position and order and every inequality of its motion, bears witness that the earth moves and that we who dwell upon the globe of the earth, instead of accepting its changes of position, believe that the planets wander in all sorts of motions of their own” (Rheticus’ *Narratio prima*, dated 1540, translated by Edward Rosen, in *Three Copernican Treatises*, New York, Octagon Books, 1971, p. 165).

¹⁵⁶¹ *De revolutionibus*, “10. Of the Order of the Heavenly Bodies,” as cited in *The Copernican Revolution*, pp. 179-180 (Kuhn’s translation from the Latin). Charles Glenn Wallis’ translation (or his editor’s), although similar, seems desirous to lessen Copernicus’ deification of the sun by using slightly different wording and lower case letters: “In the center of all rests the sun. For who would place this lamp of a very beautiful temple in another or better place than this wherefrom it can illuminate everything at the same time? As a matter of fact, not unhappily do some call it the lantern; others, the mind, the pilot of the world. Trismegistus calls it a ‘visible god’; Sophocles’ Electra, ‘that which gazes upon all things.’ And so the sun, as if resting on a kingly throne, governs the family of stars which wheel around. Moreover, the Earth is by no means cheated of the services of the moon; but as Aristotle says in the *De Animalibus*, the Earth has the closest kinship with the moon. The Earth moreover is fertilized by the sun and conceives offspring every year” (*On the Revolutions of Heavenly Spheres*, NY: Prometheus Books, 1995, pp. 24-26).

realm of ideas. Now the idea of the good is the highest in the hierarchy of Platonic ideas. Accordingly the sun, which endows visible things with their visibility, vitality, growth and progress, is the highest in the hierarchy of the visible things in nature... Now if the sun was to be given pride of place, if the sun merited a divine status... then it was hardly possible for it to revolve about the Earth. The only fitting place for so exalted a star was the center of the universe. So the Earth was bound to revolve about the sun. This Platonic idea, then, forms the historical background of the Copernican revolution. It does not start with observations, but with a religious or mythological idea.¹⁵⁶²

Popper, being a supporter of the heliocentric revolution, couches his critique of Copernicus in rather polite terms, but essentially he is saying that Copernicus' brainchild had all the earmarks of originating from pagan sun-worship. As Wolfgang Smith notes:

...in the Renaissance movement championed by Marsiglio Ficino, the doctrine came alive again, but in a somewhat altered form; one might say that what Ficino instituted was indeed a religion, a kind of neo-paganism. Copernicus himself was profoundly influenced by this movement, as can be clearly seen from numerous passages in the *De revolutionibus*.¹⁵⁶³

Upon reading *De revolutionibus*, one is struck by the preponderance of philosophical and humanistic arguments Copernicus brings to his aid. As J. D. Bernal notes: “[Copernicus’] reasons for his revolutionary change were essentially philosophic and aesthetic,” and in a later edition he is more convinced that the “reasons were mystical rather than scientific.”¹⁵⁶⁴ Overall, Copernicus presents about five-dozen arguments, at least half of which are solely philosophical in nature. Although the other half of his argumentation depends more on mechanics, these also have philosophical appendages to them. Very few

¹⁵⁶² *Conjectures and Refutations: The Growth of Scientific Knowledge*, p. 187. Popper is referring to Dominicus Maria da Novara, a mathematician and astronomer in Italy. Indulging in a bit of anachronistic evaluation, Popper goes on to defend him, suggesting that even though Copernicus' idea came before the observation, he was nevertheless correct and “not a crank.” More of Popper's *a-posteriori* thinking appears later in the book: “The Copernican system, for example, was inspired by a Neo-Platonic worship of the light of the Sun who had to occupy the ‘centre’ because of his nobility. This indicates how myths may develop testable components. They may, in the course of discussion, become fruitful and important for science” (*ibid.*, p. 257).

¹⁵⁶³ Wolfgang Smith, *The Wisdom of Ancient Cosmology*, p. 174. Copernicus was also influenced heavily by the liberal humanist, Codrus, who was known for denying various Church doctrines.

¹⁵⁶⁴ J. D. Bernal, *Science in History*, 1st edition, London, Watts, 1954; 2nd edition, 1965. Cited in Lakatos, *Methodology of Scientific Research Programmes*, p. 129.

of his arguments are based on his own personal observations, since, as we noted earlier, Copernicus merely reworked the observations of his Greek predecessors. In fact, Copernicus concludes that, because the Greeks did not detail their cosmological models more thoroughly, history (and God) have called upon him to provide the long-awaited documentation of true cosmology.¹⁵⁶⁵

Perhaps this is the reason that another disturbing aspect in Copernicus' approach to cosmology is, since he was a Canon of the Catholic Church and one who rubbed shoulders with high-placed Cardinals, in addition to being invited to audiences with the reigning pope, one might expect Copernicus would have been a high churchman in his own right, with regular recourse to the Church Fathers, especially since he knew that a good number of them wrote definitive works on cosmology and cosmogony,¹⁵⁶⁶ and of whom it was common knowledge that their consensus on important issues was the Church's most formidable weapon against erroneous ideas, even as Robert Bellarmine had taught Foscarini and Galileo.¹⁵⁶⁷ But one will search in vain for any

¹⁵⁶⁵ Thomas Heath sheds more light on this connection: "Copernicus himself admitted that the [heliocentric] theory was attributed to Aristarchus, though this does not seem to be generally known....But it is a curious fact that Copernicus did mention the theory of Aristarchus in a passage which he afterwards suppressed: 'Credibile est hisce similibusque causis Philolaum mobilitatem terrae sensisse, quod etiam nonnulli Aristarchum Samium ferunt in eadem fuisse sentential.'" Heath also shows by quotes from Plutarch and Archimedes that Aristarchus was the originator of the heliocentric view (Thomas Heath, *Aristarchus of Samos: The Ancient Copernicus*, Oxford, Clarendon Press, 1913, p. 301ff). J. L. E. Dreyer provides a more readable translation of Archimedes' words: "You know that according to most astronomers the world (κόσμος) is the sphere, of which the center is the center of the earth, and whose radius is a line from the center of the earth to the center of the sun. But Aristarchus of Samos has published in outline certain hypotheses, from which it follows that the world is many times larger than that. For he supposes (ὑποτιθέται) that the fixed stars and the sun are immovable, but that the earth is carried round the sun in a circle which is in the middle of the course..." (J. L. E. Dreyer, *History of the Planetary Systems from Thales to Kepler*, Cambridge University Press, 1906, pp. 136-137).

¹⁵⁶⁶ Chief among them were Basil the Great, bishop of Caesarea. Advancing a dogmatic assertion of geocentrism, he writes: "There are inquirers into nature who with a great display of words give reasons for the immobility of the Earth....Do not then be surprised that the world never falls: it occupies the center of the universe, its natural place. By all necessity it is obliged to remain in its place, unless a movement contrary to nature should displace it. If there is anything in this system which might appear probable to you, keep your admiration for the source of such perfect order, on the wisdom of God" (*Hexameron*, Homily 1, 10); and Chrysostom: "For they who are mad imagine that nothing stands still, yet this arises not from the objects that are seen, but from the eyes that see. Because they are unsteady and giddy, they think that the Earth turns round with them, which yet turns not, but stands firm. The derangement is of their own state, not from any affection of the element." (*Homilies on Titus* 2:1).

¹⁵⁶⁷ Bellarmine states: "Second, I say that, as you know, the Council [of Trent] prohibits interpreting Scripture against the common consensus of the Holy Fathers; and if Your

patristic references in *De revolutionibus*, or, in that case, in any of Copernicus' works. After prefacing his remarks to Pope Leo X with a castigation of those who "...although wholly ignorant of mathematics...shamelessly distorting the sense of some passage in Holy Writ to suit their own purpose," the only time Copernicus crosses the threshold into the patristic witness for Leo's sake is a disdainful remark about Lactantius, choosing him as his target of derision because, as he asserts:

For it is not unknown that Lactantius, otherwise a distinguished writer but hardly a mathematician, speaks in an utterly childish fashion concerning the shape of the Earth, when he laughs at those who have affirmed that the Earth has the form of a globe."¹⁵⁶⁸

Consequently, as a lot, the Fathers are made to appear as ignorant partisans against the goals of science and not worthy of comment on so important a subject. The reality is that Lactantius was the only Father of the Church (and he was not a highly esteemed patristic witness) who held to the idea of a non-spherical Earth.¹⁵⁶⁹ Every other Father who wrote at length on cosmological issues stated his belief, based on Scripture and science, that the Earth was a sphere.¹⁵⁷⁰ But one would

[Reverence] wants to read not only the Holy Fathers, but also the modern commentaries on Genesis, the Psalms, Ecclesiastes, and Joshua, you will find all agreeing in the literal interpretation that the sun is in heaven and turns around the earth with great speed, and that the earth is very far from heaven and sits motionless at the center of the world. Consider now, with your sense of prudence, whether the Church can tolerate giving Scripture a meaning contrary to the Holy Fathers and to all the Greek and Latin commentators" (Robert Cardinal Bellarmine to Paolo Antonio Foscarini, April 12, 1615).

¹⁵⁶⁸ *De revolutionibus*, Dedication to Pope Paul III, *Revolutions of Heavenly Spheres*, Charles Glenn Wallis, p. 7.

¹⁵⁶⁹ Lactantius, *The Divine Institutes*, Book 3, Chapter 23: "...they thought that the world is round like a ball...But if this were so, the Earth also itself must be like a globe...And if this were so, that last consequence also followed, that there would be no part of the Earth uninhabited by men and the other animals. Thus the rotundity of the Earth leads, in addition, to the invention of those suspended antipodes."

¹⁵⁷⁰ Athanasius: "And wells, again, and rivers will never exist without the Earth; but the Earth is not supported upon itself, but is set upon the realm of the waters, while this again is kept in its place, being bound fast at the center of the universe. And the sea, and the great ocean that flows outside round the whole Earth, is moved and borne by winds wherever the force of the winds dashes it." (*Against the Heathen*, First Book, Part 1, 27); Gregory of Nyssa: "As, when the sun shines above the Earth, the shadow is spread over its lower part, because its spherical shape makes it impossible for it to be clasped all round at one and the same time by the rays, and necessarily, on whatever side the sun's rays may fall on some particular point of the globe..." (*On the Soul and the Resurrection*); Augustine: "Think we, had he ascended to the peak of some very high and pointed mountain, and looked out thence and seen the compass of the Earth,

never know these essential facts from the biased Copernicus. Instead, Copernicus rests his lot with the Greek philosophers and astronomers, the very individuals against which the Church Fathers exercised most of their critiques in the areas of cosmology and cosmogony. *De revolutionibus* is saturated with nothing but praise for the Greek cosmologists, more particularly, the ones who advocated a moving Earth:

I found in Cicero that Hicetas [of Syracuse, fifth century B.C.] had realized that the Earth moved. Afterwards I found in Plutarch that certain others had held the like opinion. I think fit here to add Plutarch's own words, to make them accessible to all: "The rest hold the Earth to be stationary, but Philolaus the Pythagorean says that she moves around the [central] fire on an oblique circle like the Sun and Moon. Heraclides of Pontus and Ecphantus the Pythagorean also make the Earth to move, not indeed through space but by rotating round her own center as a wheel on an axle from West to East."¹⁵⁷¹

In the text of *De revolutionibus* he continues:

It is the vault of Heaven that contains all things, and why should not motion be attributed rather to the contained than to the container, to the located than the locater? The latter view was certainly that of Heraclides and Ecphantus the Pythagorean and Hicetas of Syracuse (according to Cicero). All of them made the Earth rotate in the midst of the Universe...That the Earth, besides rotating, wanders with several motions and is indeed a Planet, is a view attributed to Philolaus the Pythagorean, no mean mathematician, and one whom Plato is said to have sought out in Italy."¹⁵⁷²

We see that, despite the fact that the Greeks have quite a confusing assortment of views on the cosmos, Copernicus, nevertheless, is enamored with their cosmologies, and especially with their mathematics, but he endears himself only to the select few who believed

and the circles of the round world, and therefore said, 'I have seen the end of all perfection'?" (*Homilies on First John*, x, 5); Jerome: "...the sphere which I have called motionless and all that it contains will be dissolved into nothing, and the sphere in which the antizone itself is contained shall be called 'good ground,' and that other sphere which in its revolution surrounds the Earth and goes by the name of heaven shall be reserved for the abode of the saints" (*Letters*, 124, *To Avitus*).

¹⁵⁷¹ *De revolutionibus*, Dedication to Pope Paul III. Heraclides (d. 310 BC) a Greek astronomer who was one of the first to propose that the revolution of the stars around the Earth could also be understood as the Earth rotating on its axis in the midst of stationary stars.

¹⁵⁷² *De revolutionibus*, 5. *Whether Circular Motion Belongs to the Earth; and Concerning its Position*.

in heliocentrism. As we have noted earlier, the appeal to “mathematics” or “mathematical harmonies” is a common thread running through most of the new cosmology, from Copernicus to Kepler through Einstein and Quantum Mechanics. The appeal, though appearing logical and formidable, is baseless. Mathematics proves very little, except that the right side of the equation equals the left side.

Johannes Kepler

Kepler was heavily influenced by the occult, as was his mother, Katherina Kepler, and the latter's endeavor may have led to her trial as a witch.¹⁵⁷³ Following his particular philosophy, Kepler's main motivation for bringing the sun into the center of the planetary system, as had Copernicus before him, was that he considered it worthy of symbolic deification. In one passage he describes the sun as: "Who alone appears, by virtue of his dignity and power, suited...and worthy to become the home of God himself, not to say the first mover."¹⁵⁷⁴

Much more disturbing, however, is another facet to Kepler's life that has been hidden from the eyes of the world for the last four hundred years. Although most historians were aware of Kepler's nefarious inclinations wherein jealousy and ambition ruled his motives, few were prepared for what recent forensic evidence has revealed. Whereas most scholars had thought Kepler's employer, the renowned Tycho de Brahe, died of a urinary tract infection, an exhumation of his body leading to a chemical analysis of his hair shows lethal levels of mercury poisoning just hours before his death.¹⁵⁷⁵ Kepler, already steeped in the Copernican theory that he freely wielded in his Lutheran circles with little reproach, desperately needed Brahe's forty-years' worth of planet- and star-charting to bring his "*Mysterium Cosmographicum*" visions to fruition. As Kepler describes it:

¹⁵⁷³ *Kepler's Witch*, James A. Connor, Harper Collins, 2004, pp. 275-307. *The Sleepwalkers*, pp. 389-393. The woman relative who raised Katherina was executed for practicing witchcraft (John Lear, *Kepler's Dream*, University of California Press, 1965, p. 31).

¹⁵⁷⁴ *On the Motion of Mars*, Prague, 1609, Chapter 4, as cited in Thomas S. Kuhn, *The Copernican Revolution*, New York, Random House, 1959, p. 214. Kuhn notes: "This symbolic identification of the sun and God is found repeatedly in Renaissance literature and art" (*ibid.*, p. 130). Later adding: "This conviction [of Kepler's], together with certain intrinsic incongruities discussed above, was his reason for rejecting the Tychonic system" (*ibid.*, p. 214). Kepler's reference to the "first mover" encapsulates his concept that as the sun rotated on its axis, its rays would act like a brush to move the planets.

¹⁵⁷⁵ Joshua Gilder and Anne-Lee Gilder, *Heavenly Intrigue: Johannes Kepler, Tycho Brahe, and the Murder Behind one of History's Greatest Scientific Discoveries*, New York: Doubleday, 2004, pp. 145, 206-234. After several of Kepler's plots to confiscate Brahe's records were foiled (pp. 188-194) the ultimate plot was hatched. Kepler, having become familiar with Brahe's alchemical laboratory, knew the precise dosage of mercuric chloride solution that would initiate the onset of Brahe's demise. PIXE analysis [particle-induced X-ray emission] has confirmed the presence of the lethal levels of residual mercury and calcium, the latter originating from the milk that was used to camouflage the poison – a favorite medium in those times.

For among the most powerful causes of visiting Tycho was this also, that I might learn the truer proportions of the deviations [of the planets] from him, by which I might examine both my *Cosmic Mystery* and *The Harmony of the World*. For these a priori speculations ought not to impinge on clear experience: but with it be reconciled.¹⁵⁷⁶

How valuable were these charts and data? Without them Kepler would have been just another seventeenth-century astronomer struggling to make a living by reading astrological horoscopes, for he would have had little evidence upon which to base his theory regarding the motions of the planets. Modern telescopic observation reveals that, without ever using a telescope, Brahe's data of stars was consistently accurate to within 1 minute of arc or better. His observations of planetary positions were reliable to within 4 minutes of arc, which was more than twice the accuracy produced by the best observers of antiquity. In fact, it was Tycho's express desire to use his precise measurements to uncover the errors in Copernicus' solar system. This data was absolutely priceless, and Kepler, who revered Tycho and called him *The Phoenix of Astronomy*, would eventually pay, the evidence shows, the ultimate price to obtain them. Brahe knew of Kepler's intention to acquire the charts, but he wouldn't budge since he was the staunchest anti-Copernican of his day. Tycho's very first letter to Kepler outlined his express desire that his forty-years of painstaking work be used to promote the geocentric system, and he had more than a suspicion that Kepler was planning just the opposite. In the words of one author:

Kepler knew that in Tycho's possession were the raw observations that he, as "architect," longed to assemble into a coherent picture of planetary motion. And Tycho knew that the gifted Kepler had the mathematical wherewithal to prove the validity of the Tychonic [geocentric] system of the heavens. But Kepler was a confirmed Copernican; Tycho's model had no appeal to him, and he had no intention of polishing this flawed edifice to the great man's ego.¹⁵⁷⁷

¹⁵⁷⁶ *Heavenly Intrigue*, p. 154. The Gilders' add: "Kepler had not forgotten Brahe's advice; he understood that, without the empirical backing only Brahe's incomparable observations could provide, his idea of universal structure and harmony would never amount to anything but an elegant theory" (*ibid.*).

¹⁵⁷⁷ Alan W. Hirshfeld, *Parallax: The Race to Measure the Universe*, New York: W. H. Freeman and Co, 2001, pp. 92-93. Brahe was the principal author but perhaps not the only one who discovered what we now know as the Tychonic system. Helisaeus Roeslin worked on a similar system, but his work was never published. Nicholas Reimers Bär (also known as Ursus), published a Tychonic system with a rotating Earth in the *Fundaments of Astronomy* [actual title: *Nicolai Raimari Ursi Dithmarsii Fundamentum astronomicum*, Strasburg, 1588] but was known to have stolen it from Brahe, whereupon Brahe sought litigation against him, but Ursus died before the trial [see *Heavenly Intrigue*, pp. 120-185].

As the plot thickens, Kepler's diary records the following:

Let all keep silence and hark to Tycho who has devoted thirty-five years to his observations... For Tycho alone do I wait; he shall explain to me the order and arrangement of the orbits... Then I hope I shall one day, if God keeps me alive, erect a wonderful edifice.¹⁵⁷⁸

“Brahe may discourage me from Copernicus (or even from the five perfect solids) but rather I think about striking Tycho himself with a sword...I think thus about Tycho: he abounds in riches, which like most rich people he does not rightly use. Therefore great effort has to be given that we may wrest his riches away from him. We will have to go begging, of course, so that he may sincerely spread his observations around.”¹⁵⁷⁹

Scheming to come into Brahe's company, Kepler finally met him for the first time on February 4, 1600. Tycho put Kepler to work crunching numbers in the hopes of

turning his Tychonic system from a rough schematic diagram of the heavens into an accurate model from which exact predictions of planetary motion could be made...the Tychonic system – which Kepler, as a Copernican, disdained.”¹⁵⁸⁰

As Kepler describes the toil:

I would have brought my discussion about the *Harmony of the World* long ago to an end except that the Astronomy of Tycho occupied me so totally that I almost was insane.

Just eighteen months later, Brahe, although the epitome of perfect health, suddenly died. All the evidence points to Kepler as the perpetrator. With his usual knack for introspective understatements, Kepler tells his diary:

¹⁵⁷⁸ Letter to Michael Maestlin, February 16, 1599, *Gesammelte Werke*, vol. xiii, p. 289 *seq.* (cited in *The Sleepwalkers*, p. 280). Koestler adds: “With one eye he was reading the thoughts of God; the other squinted enviously at Tycho's shining armillary spheres. But Tycho refused to publish his observations until he had completed his own theory. He jealously guarded his treasure, volumes of figures, the result of a lifetime of work.”

¹⁵⁷⁹ Letter to Michael Maestlin, February 16 1599, *Gesammelte Werke*, vol. xiii, p. 289 *seq.* Partially translated from the Latin by Joshua Gilder and Anne-Lee Gilder, *Heavenly Intrigue: Johannes Kepler, Tycho Brahe, and the Murder Behind One of History's Greatest Scientific Discoveries* (Doubleday, 2004), p. 132.

¹⁵⁸⁰ *Heavenly Intrigue*, p. 157.

I confess that when Tycho died, I quickly took advantage of the absence, or lack of circumspection, of the heirs, by taking the observations under my care, or perhaps usurping them...¹⁵⁸¹

The rest is history, as they say, but it is filled with enough intrigue to make even Agatha Christie envious of the story line.

¹⁵⁸¹ Letter to D. Fabricius, February 1604, *Gesammelte Werke*, vol. xv, p. 231 *seq.*, cited in *The Sleepwalkers*, p. 350.

Galileo Galilei

Galileo followed right on the heels of Kepler. Like Kepler, he had an eccentric and irascible personality, at least up until his conversion to the geocentric cosmology revealed in his 1641 letter to Francesco Rinuccini. But whereas Kepler was more reserved, the unconverted Galileo was the quintessential know-it-all, always and everywhere trying to outshine everyone who crossed his path. As Koestler puts it:

Galileo had a rare gift of provoking enmity; not the affection alternating with rage which Tycho aroused, but the cold, unrelenting hostility which genius plus arrogance minus humility creates among mediocrities.¹⁵⁸²

Historian A. C. Custance adds:

Judging by Galileo's correspondence and other records of his opinion of himself he was fantastically selfish intellectually and almost unbelievably conceited. As an illustration of the former there is the now well-known fact that he refused to share with his colleagues or with acquaintances such as Kepler any of his own findings or insights; he actually claimed to be the only one who ever would make any new discovery!¹⁵⁸³

By the same token, Galileo would ignore the overtures of his colleagues but steal secrets behind their backs. Kepler was alerted to this fact when one of his admirers wrote to him and said: "Galileo has your book and teaches your discoveries as his own..." but which Kepler, for reasons of his own, allowed to transpire without litigation.¹⁵⁸⁴ In fact, Kepler sought Galileo's written correspondence on many occasions. In one instance he sent Galileo his magnum opus, *Mysterium Cosmographicum*, hoping for a review, but Galileo ignored all but two inquiries from Kepler, and those responses were separated by thirteen years. The second response was prompted by nothing less than a threat from Kepler to expose Galileo as a fraud unless he produced the evidence of his telescope sightings about which he had been continually bragging.

Among his other braggadocios, Galileo claimed to have invented the telescope, but Kepler and his colleagues knew it was available twenty years earlier from one of Galileo's countrymen, Giovanni Della Porta. Records also show that spectacle-maker Johann Lippershey possessed a

¹⁵⁸² *The Sleepwalkers*, p. 373.

¹⁵⁸³ A. C. Custance, "The Medieval Synthesis and the Modern Fragmentation of Thought," in *Science and Faith*, The Doorway Papers VIII, Grand Rapids, pp. 153.

¹⁵⁸⁴ *The Sleepwalkers*, p. 365.

license to make telescopes by the mid-1580s. By April 1609 one could buy a telescope from shops in Paris, the same year Galileo published that he was the first to see the moons of Jupiter, a claim which is also in doubt since there is evidence that other observations of Jupiter preceded Galileo, and that his brand of telescope was so small and clumsy it would have been hard to see Jupiter itself, let alone its moons.¹⁵⁸⁵ When Kepler pressed him to send the telescope so that his claims could be verified, Galileo gave him the typical ‘the-dog-ate-it’ excuse, claiming that he had “lent it to the Grand Duke for exhibition.” Still, Galileo managed to become the celebrated discoverer of Jupiter’s moons. The Jesuits of the Roman College layed aside a day of ceremonies in his honor and he was invited to a personal audience with Pope Paul V. Galileo followed this by naming the moons the “Medicean Stars” in honor of the Medici family who were the financial barons of Italy. Having previously dabbled in astrology, Galileo wrote a personal horoscope for Cosimo Medici, the Grand Duke of Tuscany, stating: “It was Jupiter, I say, who at your Highness’ birth...looked down upon your most fortunate birth.”¹⁵⁸⁶ Cosimo promptly elevated Galileo to the position of Galileo was promptly elevated to chief mathematician and philosopher whereupon he received a salary of 1,000 florins a year, and thus he was now financially set for the rest of his life. In his usual lack of gratitude, Galileo rarely mentions Kepler’s name in his books, and even those occasions are with the intent to refute him. It is no surprise that Galileo rejected Kepler’s three laws of planetary motion as well as his discoveries in optics. Not surprisingly, the unconverted Galileo thought he had a better idea. To one of his other rivals Galileo stated:

You cannot help it, Mr. Sarsi, that it was granted to me alone to discover all the new phenomena in the sky and nothing to anybody else. This is the truth which neither malice nor envy can suppress.”¹⁵⁸⁷

His self-appointed monopoly on the sky is probably why Galileo also claimed to be the first to discover sunspots, but the records show

¹⁵⁸⁵ Ernst Zinner, *Entstehung und Ausbreitung der Copernicanischen Lehre* (Erlangen, 1943), p. 345, cited in *The Sleepwalkers*, pp. 372-374.

¹⁵⁸⁶ *The Book that Nobody Read*, pp. 200-201.

¹⁵⁸⁷ *The Sleepwalkers*, p. 436. Taken from Galileo’s 1623 book titled *Il Saggiatore* (*The Assayer*). The book starts with a tirade against his opponents: “Others, not wanting to agree with my ideas, advance ridiculous and impossible opinions against me; and some, overwhelmed and convinced by my arguments, attempted to rob me of that glory which was mine, pretending not to have seen my writings and trying to represent themselves as the original discoverers of these impressive marvels” (“The Assayer,” *Theories and Opinions of Galileo*, translated by Stillman Drake in, New York: Doubleday, 1957, p. 274).

that the Jesuits Johannes Farricius and Christopher Scheiner and his assistant Cysat had found the spots much earlier, both of whom had published their findings separately, many months before Galileo.

Galileo's deceit reached new heights in his confrontations with the Church's Holy Office from 1616-1633. Prior to this, Galileo had made known his views of heliocentrism privately in a 1597 letter to Kepler, yet in a remarkable display of duplicity, in the intervening years between 1597 and up until 1613, he had been teaching against Copernicanism quite vigorously, complete with charts and graphs. A 1601 manuscript of his musings still survives today.¹⁵⁸⁸ Galileo was in a constant whirlwind: saying one thing and doing another, and doing one thing and saying another. Suffice it to say, after giving him every grace and favor to treat Copernicanism as a hypothesis, not fact, Galileo refused, claiming he had proof when, indeed, he had none at all. The Church hierarchy simply could not put up with his roguery any longer. His former confidant, Cardinal Barberini, later became Urban VIII, and, as pope, made it a point to condemn Galileo for lack of proof. Urban upheld the 1616 Sacred Congregation's verdict against Copernicanism, and after obtaining Galileo's renunciation in 1633, sent notice of the condemnation to all the inquisitors and papal nuncios of Europe, making it an official proclamation of the Vatican and the papacy.¹⁵⁸⁹

Having fathered two illegitimate daughters with his long-time mistress (eventually abandoning the woman), the unconverted Galileo was hardly the example of a devout Catholic. Although Galileo took his daughters with him to Florence, he soon found caring for them to be very annoying and he decided to send them to an impoverished convent. Because of what one historian calls his "irrepressible egotism" that led him to abandon them, one of the girls maintained her animosity toward him for the rest of his life.¹⁵⁹⁰ It was the other daughter who, having become a nun, was chosen to read to Galileo the daily penitential Psalms imposed upon him in exile by Pope Urban VIII.

All things considered, the unconverted Galileo was probably one of history's better examples of a sophist and propagandist. Although his

¹⁵⁸⁸ *Trattato della Sfera*, Florence, Opere, Ediz. Nazionale, Vol. II, 1929, pp. 203ff. Galileo said the Earth did not move, since if it did, the clouds could not keep up with it. Klaus Fischer surmises that often Galileo doubted the Copernican system, since he knew he had no solid proof (*Galileo Galilei*, p. 94).

¹⁵⁸⁹ As Dorothy Stimson reports, "Pope Urban had no intention of concealing Galileo's abjuration and sentence. Instead, he ordered copies of both to be sent to all inquisitors and papal nuncios that they might notify all their clergy and especially all the professors of mathematics and philosophy within their districts..." (Dorothy Stimson, *The Gradual Acceptance of the Copernican Theory of the Universe*, New York, The Baker and Taylor Company, 1917, pp. 67-68).

¹⁵⁹⁰ As quoted in: *This Wild Abyss: The Story of the Men Who Made Modern Astronomy*, Gail E. Christianson, Simon and Schuster, 1978, p. 272.

image is one of an empiricist who made no claims apart from experiment, scientifically speaking the pre-1641 Galileo often gloried in credit where no credit was due. Arthur Koestler, helps reveal the man behind the image:

The personality of Galileo, as it emerges from works of popular science, has even less relation to historic fact than Canon Koppernigk's...[H]e appears...in rationalist mythography as the Maid of Orleans of Science, the St. George who slew the dragon of the Inquisition. It is, therefore, hardly surprising that the fame of this outstanding genius rests mostly on discoveries he never made, and on feats he never performed. Contrary to statements in even recent outlines of science, Galileo did not invent the telescope; nor the microscope; nor the thermometer; nor the pendulum clock. He did not discover the law of inertia; nor the parallelogram of forces or motions; not the sun spots. He made no contribution to theoretical astronomy; he did not throw down weights from the leaning tower of Pisa and did not prove the truth of the Copernican system. He was not tortured by the Inquisition, did not languish in its dungeons, did not say 'eppur si muove'; and he was not a martyr of science.¹⁵⁹¹

The most egregious fact about the pre-1641 Galileo is that at the time he was vigorously defending Copernicanism before the Holy Office in 1633, he knew *even then* the system didn't work and that he had no substantial proof for it. Since he rejected Kepler's elliptical orbits,¹⁵⁹² and refused any compromise with the Jesuits who were going over to

¹⁵⁹¹ *The Sleepwalkers*, p. 358. Koestler adds, however, that Galileo discovered that a pendulum swings at constant frequency, regardless of amplitude, and that he invented the pulsilogium, a timing device for taking pulses, and the thermoscope, a forerunner of the thermometer (pp. 359-360). Regarding the experiment on falling bodies, I. Bernard Cohen states that Galileo's conclusion "only shows how firmly he had made up his mind before hand, for the rough conditions of the experiment would never have yielded an exact law" (*Lives in Science*, New York: Simon and Schuster, 1957, p. 14). Some admirers even revise Galileo's words to conform to the empiricist image. Broad and Wade point out Alexandre Koyré's discovery that an author added the phrase "by experiment" to Galileo's original wording: "Nevertheless, I have discovered *by experiment* some properties of it which are worth knowing and which have not hitherto been observed or demonstrated" ("Traduttore-Traditore. A Propos de Copernic et de Galilée," *Isis*, 34, 209-210, 1943; *Metaphysics and Measurement: Essays in Scientific Revolution*, Harvard University Press, Cambridge, 1968). They continue: "With Galileo, the desire to make his ideas prevail apparently led him to report experiments that could not have been performed exactly as described...The Renaissance saw the flowering of Western experimental science, but in Galileo, the propensity to manipulate fact was the worm in the bud" (*Betrayers of the Truth*, p. 27).

¹⁵⁹² Kepler tried in many instances to establish a correspondence with Galileo, but Galileo remained quite aloof, thinking he had a better answer to cosmology. He used Kepler's material, however, whenever it was to his advantage, and claimed it as his own.

Brahe's geocentric model,¹⁵⁹³ he was stuck with Copernicus' forty-eight epicycles, yet he advertised the model as one that bypassed the earlier mechanical problems "with one single motion of the Earth."¹⁵⁹⁴ It is obvious that either Galileo was lying or he never read Copernicus' book, which is one of the reasons Koestler refers to Copernicus' work as "The book that nobody read." Even Owen Gingerich, who disagrees with Koestler's general assessment that Copernicus' book was unread, agrees that Galileo didn't read it.¹⁵⁹⁵ Calling his bluff, Robert Bellarmine stated quite clearly to Galileo that the Church would not even consider changing its position on the cosmos unless Galileo could provide proof of his claims. In one of his more audacious moves, Galileo tried to prove his case by a strange concoction of theory and conjecture on the nature of tidal action. Having rejected as "occultish" Kepler's explanation that the combination of the sun's and moon's gravity caused the daily tides,

¹⁵⁹³ Koestler writes: "Jesuit Father Horatio Grassi of the *Collegium Romanum*...quoted with approval Tycho's conclusions...a further step in the Jesuits retreat from Aristotle...and a further sign of the Order's implicit endorsement of the Tychonic system" (*The Sleepwalkers*, pp. 473-474). In 1619, Grassi wrote *The Astronomical and Philosophical Balance* in support of the Tychonic system, and Galileo answered with *Il Saggiatore* (The Assayer) in 1623, which, in his usual sardonic manner, calls Brahe's 40-years worth of planet-charting mere "alleged observations" and, not believing in comets himself, assigns them the title "Tycho's monkey-planets." He berates Grassi with epithets such as "piece of asininity," "buffoon," "evil poltroon," and "ungrateful villain." De Santillana adds that some of Galileo's favorites were "mental pygmies," "dumb mooncalves" and "hardly deserving to be called human beings." In all of history, only Martin Luther surpasses Galileo in the category of producing the most caustic vitriol against his opponents.

¹⁵⁹⁴ As quoted from the third day of arguments in *Dialogue on the Flux and Reflux of the Tides*, also known from the title that Pope Urban preferred: *The Dialogue on the Two Great World Systems*. Koestler adds: "The third day is concerned with the astronomical arguments for and against Copernicus, and here Galileo is downright dishonest...that to 'save' the planets' apparent stations and retrogressions, Ptolemy had to introduce 'very great epicycles' which Copernicus was able to dispense 'with one single motion of the Earth.' But he breathes not a word about the fact that Copernicus, too, needs a whole workshop full of epicycles; he keeps silent about the eccentricity of the orbits, the various oscillations and librations, the fact that the sun is neither in the center of the motions, nor lies in their plane; in a word, he deliberately evades the real problems of astronomy which had started Tycho and Kepler on their quest....Moreover, he keeps silent about the fact that the Tychonic system fits the phenomena equally well...He employs his usual tactics of refuting his opponent's thesis without proving his own; in this case not by sarcasm, but by confusing the issue" (*The Sleepwalkers*, pp. 483-485).

¹⁵⁹⁵ After seeing hardly any annotations in Galileo's personal copy of Copernicus' *De Revolutionibus*, Gingerich notes: "I had long supposed that Galileo was not the sort of astronomer who would have read Copernicus' book to the very end. Even...when we had speculated how few early readers of *De Revolutionibus* there might have been, we had been reluctant to include Galileo in the list of readers. Unlike Reinhold or Maestlin or Kepler, he was not interested in the details of celestial mechanics" (*The Book that Nobody Read*, p. 200).

Galileo, even knowing that his own explanation could not be physically possible, nevertheless, to save his prestige, tried to convince the Catholic prelates that tides were caused by the tilt of the Earth's axis and the Earth's monthly changes in orbital velocity. In addition, his theory addressed only a 24-hour tidal cycle, but sailors knew, and reported to the common folk, that the tides alternated every 12 hours, creating two tides per day. Galileo then tried to explain the discrepancy by postulating that the ocean floor varied in depth. No wonder Koestler concludes his remarks with:

There can be no doubt that Galileo's theory of the tides was based on unconscious self-deception.... making the complexities of Copernicus appear deceptively simple, was part of a deliberate strategy, based on Galileo's contempt for the intelligence of his contemporaries. We have seen that scholars have always been prone to manias and obsessions, and inclined to cheat about details; but impostures like Galileo's are rare in the annals of science.¹⁵⁹⁶

As we noted earlier, however, Galileo finally came to his senses after his chastisement from Pope Urban VIII. Without any hint that he is speaking under duress or to save himself from further condemnation, Galileo writes his letter to Francesco Rinuccini denouncing Copernicanism in the most explicit terms. Of course, the malice with which Galileo started his highfalutin theories continues today, since hardly anyone in the world has ever heard of the fact that Galileo renounced Copernicus in favor of geocentrism.

¹⁵⁹⁶ *The Sleepwalkers*, p. 486. See also W. R. Shea and M. Artigas, *Galileo in Rome: The Rise and Fall of a Troublesome Genius*, Oxford University Press, 2003.

Isaac Newton

Although Isaac Newton is much deserved of scientific credit for at least providing mathematical formulas of motion that, within the margin of error are quite accurate, his personal life was little to be admired. Kepler's jealousy of Brahe was just slightly worse in comparison to the avarice in Newton's psyche that led him to confiscate the work of his contemporaries and credit it to himself. Case in point: astronomer John Flamsteed was the owner of voluminous notes charting lunar movements and the positions of the stars, notes Newton desperately needed to fit the moon into his gravitational theory for the publishing of his famous *Philosophiae Naturalis Principia Mathematica*. A bitter feud resulted between the two men wherein Newton, using his influence with government officials, forced Flamsteed's hand. Not only did Newton surreptitiously wrest Flamsteed from his painstaking work, he did the same to Stephen Gray and Robert Hooke. In 1666,¹⁵⁹⁷ 1674¹⁵⁹⁸ and again in 1679 in direct correspondence with Newton, Hooke published his theory of the 'inverse square law' regarding the force of gravity. Despite admitting in his letter to Hooke that Hooke retained the priority of the discovery, Newton tried to claim it as his own, feigning that he had thought about it many years earlier but didn't decide to publish it in his own book until thirteen years after the initial ideas came to him. As historian Ellen Tan Drake notes:

Newton, however, claimed to have arrived at his universal law of gravitation at his country home in Woolsthorpe during the plague years 1665 or 1666 (it is not clear which), during his *annus mirabilis* (this "marvelous year" when the legendary apple fell). This date, of course, would clearly predate Hooke's expression of the law except that there is clear proof that as late as 1675, Newton still thought that the planets and Sun were kept apart by "some secret principle of unsociableness in the ethers of their vortices," and that gravity was due to a circulating ether that had to be replenished in the center of the Earth by a process like fermentation or coagulation.¹⁵⁹⁹

¹⁵⁹⁷ Lecture given to the Royal Society titled *Planetary Movements as a Mechanical Problem*, on May 23, 1666, as reproduced in *Early Science in Oxford* by R. T. Gunther, Oxford University Press, 1930, ref. 1, Vol. vi, p. 256..

¹⁵⁹⁸ Hooke's monograph: *An Attempt to Prove the Motion of the Earth by Observation*, London, 1674, as reproduced in *Early Science in Oxford* by R. T. Gunther, Oxford University Press, 1930, ref. 1, Vol. vii, pp. 1-28.

¹⁵⁹⁹ *Restless Genius: Robert Hooke and his Earthly Thoughts*, Ellen Tan Drake, Oxford University Press, 1966, pp. 32-33. Drake's source is Newton's letter to Oldenberg, Dec. 7 1675, as cited in Turnbull, 1959, vol. 1: 368; Patterson, 1950. John Aubrey in *Aubrey's Brief Lives*, University of Michigan Press, 1957, p. 166, also confirms that Hooke's discovery of the Inverse Square Law predated Newton's *Principia*.

Newton won the day against Hooke by using his influence at the Royal Society, just as he did in heading off the new discoveries of Robert Boyle, all in an effort to advance his own career.¹⁶⁰⁰ On at least three separate occasions Newton introduced fallacious figures into the *Principia* in order to increase its apparent power of prediction.¹⁶⁰¹ Because of Newton's vast social influence, the book was considered an "epoch-making" work long before it was thoroughly reviewed, the highly popular John Locke having accepted it based merely on the word of Newton.¹⁶⁰²

In addition to the ill-treatment he gave to his scientific colleagues, Newton was rumored to have had a homosexual relationship with one John Wickins, a friend with whom he had lived for twenty years. He is also said to have had a liaison with Nicholas Fatio De Duillier, a man twenty years his junior and with whom he exchanged intimate letters, many of which were later censored by Newton or a confidant. Newton was also deep into alchemy (illegal at the time) and the Jewish Kabbalah, the occult musings of medieval Talmudic authors. Although he was reputed to have Christian moorings, Newton embraced the heresy of Arianism (i.e., the denial of both the divinity of Christ and the Trinity).¹⁶⁰³

¹⁶⁰⁰ David Clark and Stephen P. H. Clark, *Newton's Tyranny: The Suppressed Scientific Discoveries of Stephen Gray and John Flamsteed*, New York: W. H. Freeman and Co., 2001; Richard S. Westfall, *Never at Rest: A Biography of Isaac Newton*, Cambridge University Press, 1981, 1983, pp. 471f, 601f; on Robert Boyle see *False Prophets*, Alexander Kohn, Oxford, Basil Blackwell Ltd., 1986, p. 39.

¹⁶⁰¹ "Newton and the Fudge Factor," Richard S. Westfall, *Science*, 179, 751-758, 1973; *False Prophets*, Alexander Kohn, Oxford, Basil Blackwell Ltd., 1986, pp. 36-39.

¹⁶⁰² Richard S. Westfall, *Never at Rest: A Biography of Isaac Newton*, Cambridge University Press, 1981, 1983, pp. 469-470; Morris Kline, *Mathematics in Western Culture*, Oxford University Press, 1953, p. 230. See also Kline's *Mathematics: The Loss of Certainty*, Oxford University Press, 1982.

¹⁶⁰³ Westfall writes: "In Newton's eyes, worshiping Christ as God was idolatry, to him the fundamental sin" (Richard S. Westfall, *Never at Rest: A Biography of Isaac Newton*, Cambridge University Press, 1981, 1983, p. 314). On Newton's intimacy with Wickens and Fatio, see *Isaac Newton: The Last Sorcerer*, Michael White, MA: Perseus Books, 1997, pp. 235-254. In addition, Voltaire had accused Newton of using his niece to entice politicians so that Newton could gain various positions of prestige. Voltaire writes: "I thought in my youth that Newton made his fortune by his merit. I supposed that the court and the city of London named him Master of the Mint by acclamation. No such thing. Isaac Newton had a very charming niece, Madame Conduitt, who made a conquest of the minister of Halifax. Fluxions and gravitation would have been of no use without a pretty niece" (*Dictionnaire Philosophique*, as cited in N. Martin Gywnne's *Sir Isaac Newton and Modern Astronomy*, Britons Catholic Library, n. d., p. 8). Biographer Richard Westfall, although an admirer of Newton and predisposed to dismiss any hearsay, adds: "The wider ramifications with Halifax, and Newton's involvement in it, do not evaporate with equal ease," although "With Halifax the libertine, Victorian eulogizers could not bear to associate Newton. Nor could they bear

Unknown to most, Newton spent most of his time interpreting biblical prophecy, writing over a million words on the subject. One of his more intriguing predictions is the date of 2060 AD as the end of the world, but that date surfaces only because Newton decided that the Roman Catholic Church was the Antichrist. Since he arbitrarily chose the Church's historical peak as occurring in 800 AD, upon which, if one adds the 1260 days of Apocalypse chapters 11-13 but changes them to 1260 years, then one obtains $800 + 1260 = 2060$.¹⁶⁰⁴ As Westfall says, Newton "hated and feared popery,"¹⁶⁰⁵ and as Koestler concludes, Newton was "a crank theologian like Kepler...and held that the tenth horn of the fourth beast of the Apocalypse represented the Roman Catholic Church."¹⁶⁰⁶

the thought, the point of Voltaire's jibe, that Newton used the degradation of his niece to advance his own career." (*Never at Rest: A Biography of Isaac Newton*, Cambridge University Press, 1981, 1983, pp. 596-597).

¹⁶⁰⁴ Newton borrowed the '1260 days = 1260 year' scheme from the Puritan mystic Joseph Mede. Mede added the 1260 years to 400-455 AD and held that the end of the world would come around 1760-1815 AD. Others began at different dates (e.g., Bengel at 576; Ellicott at 608; Melancthon at 660, et al., most trying to bring the terminus to the Reformation). Newton believed that the Second Coming of Christ would follow plagues and war and would precede a 1,000-year reign of Christ and the saints on Earth, otherwise known today as "premillennialism." He spent close to 50 years delving into biblical prophecy, writing over 4,500 pages in an effort to determine the end of the world. Many of these papers had lain undisturbed in the house of the Earl of Portsmouth for 250 years, which were eventually sold by Sothebys in the late 1930s. Of the various dates he proposed, one of the last, which he apparently wrote on a separate piece of paper, was 2060. This collection of papers was purchased by Abraham Yahuda, and was stored in the Hebrew National Library. It was among these documents that the date 2060 was found. (See also Michael White's *The Last Sorcerer*, pp. 156-157).

¹⁶⁰⁵ Richard S. Westfall, *Never at Rest: A Biography of Isaac Newton*, Cambridge University Press, 1981, 1983, p. 483.

¹⁶⁰⁶ Arthur Koestler, *The Sleepwalkers*, p. 536.

Albert Einstein

Albert Einstein's biography is one of the more lurid in the annals of science, but most of it has been hid from the public for many years. Although *Time* magazine named him "Person of the Century,"¹⁶⁰⁷ up until recently few in modern history have had the privilege of being shrouded in as much impenetrable media insulation as Einstein, that is, until the executors of his estate deceased (Helen Dukas d. 1982; Otto Nathan d. 1987),¹⁶⁰⁸ and which precipitated the release of many of Einstein's personal papers that had been previously censored. In the information contained therein we find that a Mr. Hyde hid close behind the Dr. Jekyll commonly portrayed by the wire-haired, absent-minded professor.

Einstein's exploits began early in his career. He fathered a daughter out of wedlock with Mileva Marić, although the couple eventually married. They named the child Lieserl, but that is all the attention she would ever receive from Einstein. He persuaded Mileva to give the child to an orphanage so that he could avoid the social repercussions of having an illegitimate daughter. He handled it as a mere business transaction, for he never saw Lieserl face-to-face. As biographer Michele Zackheim explains it:

¹⁶⁰⁷ Stephen Hawking, "Person of the Century," *Time Magazine*, December 31, 1999. *Time* lavished praise on Einstein with such phrases as: "first among the century's giants," "its greatest scientific genius," "the person who, for better or worse, personified our times and will be recorded in history as having the most lasting significance," "the world's first scientific celebrity," "the century's greatest thinker," and "the patron saint of distracted schoolkids." Such unqualified admiration for Einstein is quite sacrosanct in the scientific field. In the book *Einstein's Unfinished Symphony* by Marcia Bartusiak (New York, Berkley Books, 2000, p. 4), MIT scientist Rainer Weiss, working on the federally funded LIGO system to test for gravity waves to confirm General Relativity, is quoted as saying: "The worship of Einstein, it's the only reason we're here, if you want to know the truth." Incidentally, Bartusiak's book is titled "Unfinished Symphony" because, of all the LIGO systems built across the world, no one has ever detected General Relativity's "gravitational wave" (*ibid.*, p. 10).

¹⁶⁰⁸ Helen Dukas had motivation to do so, since she met Einstein in 1928 when Einstein's second marriage [to his cousin Elsa Löwenthal] was rapidly deteriorating, of which Elsa "sought as far as possible to block the subject of infidelity from her mind" (*The Private Lives of Albert Einstein*, p. 210). Zackheim adds: "Hans Albert suspected they were lovers. His allegation was fortified by the proximity of her room in Princeton – just off Albert's study and down the hall from Elsa's. In addition, Einstein left Dukas more money in his will than any other member of his blood family, as well the net income from his royalties and copyright fees and all his books and personal effects" (*Einstein's Daughter: The Search for Lieserl*, p. 253). Highfield and Carter add: "Dukas became fiercely loyal to her employer: she was liable to attack as 'dung' any biography that dared shed light on Einstein's personal life, and she saw newsmen as her 'natural enemies'" (*The Private Lives of Albert Einstein*, p. 211).

Einstein scholars have concluded from his September 19 [1903] letter that the couple had decided to put Lieserl up for adoption, based on Albert's concern that the child's registration (or lack thereof) not be a source of trouble for her – or her parents – in the years to come...Apparently, in the end, Albert and Mileva agreed it would be best to pretend that Lieserl had never existed. And so, with a deliberate hand, the short life of Lieserl Einstein-Marić was erased.¹⁶⁰⁹

That such callousness wasn't just an incidental quirk is demonstrated when Einstein later forsook his son Eduard and consigned him to a sanatorium so that he could be relieved of the financial responsibility of Eduard's care and take full advantage of the public funding available. Eduard eventually died in the sanatorium.¹⁶¹⁰

Einstein's indifference to his children, however, was overshadowed by the animosity he showed to his wife. According to the divorce papers, Mileva was the victim of physical violence in the marriage, and Einstein's adultery was the final straw that led to the legal separation in 1914 and final divorce in 1919.¹⁶¹¹ As the marriage to

¹⁶⁰⁹ *Einstein's Daughter: The Search for Lieserl*, pp. 52-53. Zackheim also concludes from her massive evidence that Lieserl had a severe mental handicap, which helped seal the Einsteins' decision, and that she died at twenty-one months old, on September 21, 1903. Mileva's father was given the task of making sure that no official records concerning her short life remained in any governmental or church repositories (*ibid.*, pp. 276-277). Highfield and Carter describe the situation: "There is no evidence that Einstein and his daughter ever set eyes on one another. For all his apparent enthusiasm after the birth, it seems that his main concern was to free himself of this burden at the earliest opportunity. Lieserl's existence was kept hidden even from his closest friends, and within months she had disappeared from his life without trace. Einstein was never to talk of her publicly, and Lieserl might have been erased from history had it not been for the discovery of his letters to Mileva by the Einstein papers project...The dangers that seemed to preoccupy him were unconnected to the child's illness: his question about registration strongly suggests that she was being surrendered for adoption, and that Einstein was eager to cover his tracks. The lack of any official record of the birth would appear to be a tribute to the thoroughness of the precautions that he referred to. Lieserl's birth posed a threat to Einstein's new start as a patent examiner in Berne. He had gained Swiss citizenship only a year earlier, and the stigma of an illegitimate child would have harmed his prospects...The couple's meager income may have provided another motive for giving the child away..." (*The Private Lives of Albert Einstein*, pp. 88-90).

¹⁶¹⁰ Mileva wrote to Albert: "You have here a dear, seriously ill child. Often he asks if his father will come, and with each postponement, he becomes even more morose. He is terribly wounded." Albert refused to come back to Zurich to see Eduard. And he refused to acknowledge the financial and psychological battles that Mileva had to wage over his care" (*Einstein's Daughter*, p. 190).

¹⁶¹¹ Zackheim writes: "He tended to have a few romances going at once, but after Mileva, he was known to prefer simpler women" (*Einstein's Daughter*, p. 227). Highfield and Carter write: "Einstein was obliged to admit in his legal submissions that he had committed adultery. There were also references to fierce fights between him and his wife, which had made their continued marriage intolerable" (*The Private Lives of*

Mileva began to deteriorate, “Einstein established himself in a bachelor apartment around the corner from Elsa,” his cousin and next love interest, whom he eventually married in 1919, only four months after his divorce.¹⁶¹² In one of his more audacious moves, Einstein had actually pleaded with Mileva to allow him to marry Elsa, using as his excuse that Elsa’s daughter “...had to suffer from rumors that have been circulating regarding my relationship with her mother. That weighs upon me and needs to be remedied through a formal marriage.”¹⁶¹³ If this had been the real motive for Einstein’s pleading, we might be tempted to conclude that he was merely a deranged individual who had lost touch with reality. The real truth is even more sinister and shocking. The thirty-nine-year-old Einstein was actually in a debate with himself whether he should marry Elsa or her twenty-year-old daughter, Ilse, while all along he had been shacking up with Elsa (for the four years prior), and while still married to Mileva. As Zackheim explains:

Albert Einstein, p. 188). Zackheim gives the wording of the deposition from Einstein’s own hand: “...It is true that I have committed adultery. I have been living for approximately four and one-half years with my cousin, the widow Elsa Löwenthal, and since then I have had intimate relations with her. My wife, the plaintiff, has been informed that I have had intimate relations with my cousin since the summer of 1914” (*Einstein’s Daughter*, p. 87). In a related incident, the biographers add: “The following day Lisbeth and her mother visited Mileva and found her face badly swollen. It seems that Lisbeth may have been suggesting that Mileva had been beaten. Einstein was a powerful man and, for what it is worth, Hans Albert recalled that when he misbehaved his father ‘beat me up’. It is known that Einstein’s divorce papers – which remain under seal in Jerusalem – refer to violence within the marriage” (*The Private Lives of Albert Einstein*, pp. 153-154; See also *Einstein’s Daughter*, p. 73). After Mileva suspected an affair between Albert and Anna Meyer-Schmid, Albert complained that this “was typical in a woman of such ‘uncommon ugliness,’” adding, “Professor John Stachel says this remark was the first to shock him as he worked through Einstein’s papers after his appointment as their editor” (*Private Lives*, pp. 125-126). Mileva describes herself as “starved for love” as early as 1900 (*ibid.*, p. 128). See also *In Albert’s Shadow: The Life and Letters of Mileva Marić*, pp. 16-17.

¹⁶¹² *The Private Lives of Albert Einstein*, p. 172. Yet, Highfield and Carter add: “But there is no evidence that Mileva believed her husband was about to be stolen from her, battered though their marriage was. Einstein...had no plans to leave her. Instead he intended to pursue his affair while remaining her husband. ... He remarked to Elsa ‘But the order is always to pretend. Only when we are born and when we die are we permitted to act in an honest way’” (*The Private Lives of Albert Einstein*, pp. 163-164); “Mileva would remain a virtual invalid for three years after Albert’s decision to end the marriage...” (*In Albert’s Shadow*, p. 19). Prior to his involvement with Elsa, Einstein had a short fling with Paula Einstein, Elsa’s sister, but soon ended the relationship. He then wondered why he had become involved with her, settling for the rationale that “she was young, a girl, and complaisant. That was enough” (*Einstein’s Daughter*, p. 72).

¹⁶¹³ *Einstein’s Daughter*, p. 85.

Albert was not being honest [with Milvea]. By May [1918], he had made it clear that he wanted to marry Elsa's daughter Ilse. Ilse reported to a friend, Georg Nicolai: 'Yesterday, suddenly the question was raised about whether A[lbert] wished to marry Mama or me...A[lbert] himself is refusing to take any decision, he is prepared to marry either Mama or me. I know that A[lbert] loves me very much, perhaps more than any other man ever will, he also told me so himself yesterday...' ¹⁶¹⁴

In the waning months of his time with Mileva, records made public in 1996 show that Einstein gave her a list of conditions in order for her to remain under his financial care:

- (A) You will see to it: (1) that my clothes and linen are kept in order; (2) that I am served three regular meals a day in my room; (3) that my bedroom and study are always kept in good order and that my desk is not touched by anyone other than me.
- (B) You will renounce all personal relationships with me, except when these are required to keep up social appearances. In particular, you will not request: (1) that I sit with you at home; (2) that I go out with you or travel with you.
- (C) You will promise explicitly to observe the following point in any contact with me: (1) You will expect no affection from me and you will not reproach me for this; (2) You must answer me at once when I speak to you; (3) You must leave my bedroom or study at once without protesting when I ask you to go; (4) You will promise not to denigrate me in the eyes of the children, either by word or deed. ¹⁶¹⁵

Mileva was apparently no fool. A few months after receiving the above letter she moved to Zurich with her children and never returned to Einstein.

¹⁶¹⁴ *Einstein's Daughter*, pp. 85-86. Zackheim adds: "At the top of the letter, Ilse had written, 'Please destroy this letter immediately after reading it!'" Shortly after Ilse wrote this letter, Albert wrote to Mileva and told her that he had changed his mind about coming to see the boys in the summer. Instead, he had decided to go to Ahrenshoop, a remote village on the Baltic Sea, with Elsa, Ilse, and Ilse's younger sister, Margot" (*ibid.*, p. 86). Sixteen years later when Ilse lay dying of cancer in Paris at age 34, Elsa asked Albert to go to her bedside but he refused (*A World Without Time: The Forgotten Legacy of Gödel and Einstein*, Palle Yourgrau, New York, Basic Books, p. 148).

¹⁶¹⁵ *London Daily Telegraph*, October 30, 1996; *Einstein's Daughter*, p. 77. In one of his love letters to Elsa, Einstein wrote: "I treat my wife as an employee whom I cannot fire. I have my own bedroom and avoid being alone with her" (*Einstein's Daughter*, p. 73).

Things fared no better for Elsa, the eventual winner of the ‘Elsa versus Ilse’ contest. Einstein persuaded Elsa to divorce her husband, Max Löwenthal, so that the two lovers could marry. But this marriage shortly began to deteriorate due to Einstein’s sexual affairs. According to one biographer, “she told him he could have a woman on the side, but only one at a time,”¹⁶¹⁶ and to her dismay, Einstein’s adultery was, indeed, serial.¹⁶¹⁷ As he had with Mileva, Einstein recast their relationship as one of mere convenience. She died in 1936, nineteen years before Einstein.

Within the amoral scientific community it is rather amazing to read other scientists’ description of this part of Einstein’s life. For example, Ludwik Kostro, concealing any unethical behavior on the part of Einstein, writes: “His wife and two sons left him soon after that, moving back to Zürich, and it was a shock to him. After she left him, he rented a bachelor flat at 13 Wittelsbacherstrasse.”¹⁶¹⁸ Yet perhaps the reason Kostro writes such a biased description is that he is citing one of the chief biographies of Einstein, which is itself a systematic and deliberate attempt to conceal Einstein’s immorality. The book is *Subtle is the Lord* written by Abraham Pais.¹⁶¹⁹ The mere title implies that Pais set out to idolize Einstein and make it appear as if his theories were divinely endorsed, if not inspired. Although Roger Penrose is honest enough in the Foreword to admit that: “Einstein was certainly no saint,”¹⁶²⁰ his penetration stops there, and following him, Pais fails to mention even one incident of Einstein’s unethical or immoral behavior in his entire 552 page treatise. Whenever accusations of plagiarism surface against Einstein, Pais invariably makes it appear as if Einstein miraculously and coincidentally came to the same idea by his own independent study. Whenever Einstein is guilty of abandoning his family, Pais invariably makes it appear as if Einstein is a dedicated father who is misunderstood.

¹⁶¹⁶ From biographer Michael Shara, *Discover*, September 2004, pp. 29-30. Highfield and Carter write: “It has to be said that Elsa was not the only one of Einstein’s female relatives to catch his eye. It appears that, either during this trip or some time earlier, he had also flirted with her younger sister, Paula” (*The Private Lives of Albert Einstein*, p. 148).

¹⁶¹⁷ Highfield and Carter note: “Einstein joked that he preferred ‘silent vice to ostentatious virtue,’ but there was little that was furtive about his affairs. Either they were conducted in open view, or easy clues were left for Elsa to discover. Another incident...gives the impression that Einstein was eager for his wife to know what he was up to...” (*The Private Lives of Albert Einstein*, p. 209).

¹⁶¹⁸ *Einstein and the Ether*, Aperion, 2000, p. 57.

¹⁶¹⁹ Abraham Pais, *Subtle is the Lord: The Science and Life of Albert Einstein*, Foreword by Roger Penrose, Oxford University Press, 1982, 2005. Kostro cites pp. 224, 240.

¹⁶²⁰ Abraham Pais, *Subtle is the Lord: The Science and Life of Albert Einstein*, Foreword by Roger Penrose, Oxford University Press, 1982, 2005, p. ix.

Whenever Einstein is guilty of adultery, Pais divulges no mention of such improprieties; instead he makes Einstein's wives appear as if they are neurotic, referring to Mileva as a "difficult woman, distrustful of other people and given to spells of melancholy,"¹⁶²¹ but never making so much as a suggestion that she might have fallen into such mistrust and depression because her husband was committing some of the worst sins against her and the family that society has ever witnessed.

In addition to his sexual escapades, Einstein was suspected of plagiarism and failing to give scientific credit to Mileva who helped him develop his theories.¹⁶²² One of the biggest myths surrounding the aura of Einstein is that he was the inventor of the famous $E=mc^2$ formula. In actuality, there were at least a dozen scientists who had either developed or employed the formula prior to Einstein. (See Appendix 3).

Other instances of Einstein's outright plagiarism abound. Although Abraham Pais does his best either to minimize or to make these incidents coincidental, the facts speak for themselves.¹⁶²³ One of the more notable instances occurs in September 1924. At a meeting of famous physicists Einstein proposed that the community investigate interference and diffraction phenomena with molecular beams. Louis de Broglie, however, had already been working on the idea for quite a while

¹⁶²¹ Abraham Pais, *Subtle is the Lord: The Science and Life of Albert Einstein*, Foreword by Roger Penrose, Oxford University Press, 1982, 2005, p. 301. Pais complete description of these events is limited to pages 300-301. The reader would simply have no inkling to Einstein's malice upon reading Pais' biography.

¹⁶²² Highfield and Carter note: "As he grew older, Einstein had begun to express some very bitter feelings towards the opposite sex" (*The Private Lives of Albert Einstein*, p. 209). On the accusations of plagiarism, see C. J. Bjerknes, *Albert Einstein: The Incurable Plagiarist*, Downers Grove, IL, XTX Inc., 2002; R. Carroll, "Einstein's $E = mc^2$ 'was Italian's idea,'" *The Guardian*, Nov. 11, 1999; G. H. Keswani, "Origin and Concept of Relativity," *British Journal of the Philosophical Society*, 15:286-306, 1965; Richard Moody, Jr., "Plagiarism Personified," *Mensa Bulletin*, 442, Feb.: 5, 2001; *The Private Lives of Albert Einstein*, pp. 108-109.

¹⁶²³ Abraham Pais, *Subtle is the Lord: The Science and the Life of Albert Einstein*, Oxford University Press, 1982, 2005. Pais claims Einstein's ignorance in many instances: "In 1905, at that time [he was] aware only of Lorentz's writing up to 1895" (*ibid.*, p. 21); "...in the period of 1902-04...his knowledge of the writings of Ludwig Boltzmann was fragmentary and he was not at all aware of the treatise by Josiah Willard Gibbs" (*ibid.*, p. 55); "In 1905, Einstein was blissfully unaware of the detailed history of Brownian motion. At that time, he knew neither Poincaré's work on relativity..." (*ibid.*, p. 94); "By a quite remarkable coincidence, Eq. 5.12 was discovered in Australia at practically the same time Einstein did his thesis work. In March 1905 William Sutherland submitted a paper that contained the identical result..." (*ibid.*, p. 92); and claims that Einstein knew nothing of the work of David Hilbert: "Five days earlier, David Hilbert had submitted a paper...which contained the identical equation but with one qualification. Einstein, having learned the hard way from his mistakes a few weeks earlier..." (*ibid.*, p. 257), yet in all these cases Einstein's work contains other men's ideas and equations.

and eventually published a paper on it in November 1924. As it turns out, de Broglie had sent a copy of the unpublished manuscript to Paul Langevin some months earlier, and Langevin had passed it to Einstein, whereupon Pais records Einstein's reaction that de Broglie's ideas "seemed quite interesting to him."¹⁶²⁴ Obviously, Einstein obtained the notion of searching for "interference and diffraction phenomena with molecular beams" from de Broglie's unpublished paper, but he failed to mention de Broglie's work to the September 1924 audience of physicists, thus leaving the impression that this was all his idea. De Broglie himself says: "I am certain that Einstein knew of my Thèse since the spring of 1924."¹⁶²⁵ In the face of all this weighty circumstantial evidence, Pais, as he is prone to do in his biography, glosses over them and concludes: "Thus, Einstein was not only one of the three fathers of the quantum theory, but also the sole godfather of wave mechanics."¹⁶²⁶

Physically speaking, the youthful Einstein was the epitome of strength and vigor, since he was by common standards very muscular and attractive. But as the years wore on Einstein became grossly unhygienic, refusing to brush his teeth or even change his clothes. The image of the unkempt, wire-haired professor is not the prop of a Hollywood producer but the symptoms of a man who was losing his grip on life.¹⁶²⁷

Eventually, the promiscuous lifestyle of his earlier years may have finally caught up with him. Einstein's personal doctor, János Plesch, who knew him quite well, concluded that he died of syphilis, demonstrating from the results of the autopsy that the abdominal aneurysm that took his life is always associated with the tertiary stage of the dreaded disease, which can be 25 years or longer from time of onset. Historians Highfield and Carter write that, in an April 18, 1955 letter to his son Peter, remarking on Einstein's sexual escapades, Plesch stated:

"Why shouldn't a healthy and beautiful man have had bad luck in his youthful daredevil days and contracted a lues [syphilis]?" Plesch insisted that Einstein's symptoms were entirely

¹⁶²⁴ *Subtle is the Lord: The Science and the Life of Albert Einstein*, p. 438.

¹⁶²⁵ Letter to Abraham Pais from Louis de Broglie, September 26, 1978, cited in *Subtle is the Lord*, p.438.

¹⁶²⁶ *Subtle is the Lord*, p. 438.

¹⁶²⁷ *The Private Lives of Albert Einstein*, Robert Highfield and Paul Carter, NY, St. Martins Press, 1993, pp. 59-217; *In Albert's Shadow: The Life and Letters of Mileva Marić*, ed. Milan Popović, Baltimore: Johns Hopkins Univ. Press, 2003, pp. 16-27; "Whose Relativity Was It, Anyway?" Patricia Nemo, *College of St. Thomas Magazine*, Spring 1990, pp. 22-25; "Sex-mad Father of Relativity left family out of equation," *London Daily Telegraph*, Anthea Hall, July 25, 1993; "Relatively imperfect genius," *Jewish Chronicle*, Monica Porter, August 8, 1993.

consistent with the disease, and boasted that in all his years of medical practice he had never once been wrong in tracing an abdominal aneurysm to this cause.¹⁶²⁸

Michele Zackheim's research reveals the following:

He [Plesch] also insisted that Albert had syphilis, the 'gentlemen's disease.' "In my long medical practice I have found, almost without exception, that abdominal aneurysms which Einstein suffered from are syphilitic in origin. It might, of course, be that Einstein was exceptional in that respect too and that his aneurysm was nonspecific. However, an earlier syphilitic infection is also indicated by the fact that he suffered from extensive secondary anemia attacks...I think the infection was acquired during the interval [between his marriages].... Even though many may shake their heads about this, I am adhering to my thesis."¹⁶²⁹

¹⁶²⁸ *The Private Lives of Albert Einstein*, pp. 265-266. The biographers add: "It appears that the same thoughts may have been occupying Seelig, for the cause of the aneurysm was a point on which he had been pressing Nathan....One is tempted to wonder whether the possibility of syphilis had occurred to Nathan too. Dr. Harvey has stated that, medically speaking, Plesch 'had justification for thinking along those lines,' but added, 'It is known that tertiary syphilis does cause aneurysms, but not in this location very often'" (*ibid.*, p. 266). Mileva's letters reveal that in Albert's reading of the book *Die Sexuelle Frage*, he had underlined the parts dealing with venereal disease. Zackheim notes: "this highlighted passage about venereal disease suggests that Mileva apparently worried about Albert's sexual life outside their bedroom. Furthermore, Einstein historians believe that Albert frequented prostitutes before he married, and that Mileva may have been aware of it" (*Einstein's Daughter*, p. 268). "...Janos Plesch, who described his friend [Einstein] as a man with a strong sex drive... 'in the choice of sex partners he was not too discriminating,' wrote Plesch... 'Einstein loved women, and the commoner and sweatier and smellier they were, the better he liked them'" (*The Private Lives of Albert Einstein*, p. 206); "Einstein was also voicing deep misgivings about the institution of holy matrimony. He told Plesch that it must have been invented 'by an unimaginative pig,' and...it was 'slavery in a cultural garment'" (*ibid.*, p. 210). Deborah Hayden's article, titled "Syphilis in the Einstein Factory," says that the interest level from other biographers regarding the possibility that Einstein contracted syphilis is practically nil. In order to protect Einstein, most have ignored or ridiculed the suggestion, yet Einstein's numerous sexual affairs remain an open book. Some doctors claim that abdominal aneurysms are not all caused by syphilis although they admit that many cases are (from 6-17-05 letter from Deborah Hayden on file, used with permission).

¹⁶²⁹ *Einstein's Daughter: The Search for Lieserl*, p. 255. Zackheim adds: "Dr. János Plesch had maintained that Albert contracted syphilis sometime between leaving Mileva and marrying Elsa. But Albert could have contracted the disease prior to 1910, when he began to exhibit active interest in other women. If Albert had contracted syphilis before Mileva became pregnant with Eduard, in November 1909, or even before Lieserl was born, in 1902, he might have passed the syphilis to Mileva, who could have been a latent carrier. She, in turn, could have passed it to a baby *in utero*. The closer to conception that the mother is infected, the greater the risk of congenital syphilis in the fetus, which can result in a variety of birth defects from skin lesions to a failure to thrive to an enlarged liver and spleen to mental retardation. But with a mother

For the record, syphilis is purported to be the impetus for the genius, and often the eventual madness, of many notables in history (e.g., Beethoven, Capone, Dostoyevsky, Goya, H. Hughes, Hitler, Joyce, Lenin, Lincoln, Mozart, Napoleon, Nietzsche, Poe, Roosevelt, Toulouse-Lautrec, van Gogh, Wilde, et al.).¹⁶³⁰ Whether or not this phenomenon had anything to do with Einstein's theories, we simply do not have enough evidence to make a firm conclusion.

On the religious side of things, Mileva and her children converted to Catholicism in 1905, a fact little advertised by the secular press, then or now.¹⁶³¹ The year 1905, of course, was when his Relativity theory was introduced to the scientific community. Unmoved by his wife's religious life, Einstein wrote to his confidante Professor Hurwitz: "They've turned Catholic. Well, it's all the same to me."¹⁶³²

Einstein was, for all intents and purposes, an atheist.¹⁶³³ Any notions he had of God were of an entity completely impersonal and uninvolved with human affairs. His path toward allowing science to unseat Scripture and the Church as the ultimate authority for any intellectual endeavor that crossed its domain had begun very early in his life. After receiving instruction up until the age of twelve at Bavarian

who is a latent carrier, a healthy child can be born between two syphilitic children. Hans Albert, Mileva and Albert's only healthy offspring, was a middle child" (*ibid.*, p. 268). Despite his candidness about Einstein's syphilis, Plesch had written a much softer biography of Einstein, after having discussed its contents with Einstein. In remarking on the book, Plesch tells Einstein: "You can believe me that while I was writing these seven hundred pages, I was laughing a lot about how marvelously we are all trained to lie and how little human beings are allowed to state the truth. Our good Ibsen hit the nail on the head when he said, 'Take somebody's life lie away and you will take away his whole life.' The book is written with this compromise" (*ibid.*, p. 249). Unfortunately, the publisher destroyed the book.

¹⁶³⁰ *Pox: Genius, Madness and the Mysteries of Syphilis*, Deborah Hayden, Basic Books, 2003, p. 306f.

¹⁶³¹ *Einstein: The Life and Times*, Ronald W. Clark, p. 139.

¹⁶³² *Einstein: Life and Times*, p. 139. When Einstein reached his heyday in the world, Cardinal O'Connell of Boston concluded that Relativity theory "cloaked the ghastly apparition of atheism" and "befogged speculation, producing universal doubt about God and His Creation" (*ibid.* p. 502).

¹⁶³³ *The Private Lives of Albert Einstein*, p. 18. The authors write: "Einstein's views were atheistic in almost every important respect. He found it impossible to conceive of a personal deity, had no belief in an afterlife and considered morality an entirely man-made affair. His worship of cosmic harmony was genuine; his claims that this was the face of God were at best benign affectation." Highfield and Carter add that Einstein's pupil in Zurich, David Reichinstein, writes of a "Messiah-feeling" unfolding in Einstein's psyche, so much so that "his account contains dark hints that Einstein's arrogance bordered on hubris" (*ibid.*, p. 127). "Einstein was well aware that his harsh attitude disturbed people" (*ibid.*, p. 180).

schools, which included teaching on the Catholic faith (and in particular the traditional six-day creation), Einstein later reflected that in “reading of popular scientific books” he “soon reached the conviction that much in the stories of the Bible could not be true.”¹⁶³⁴ At another time he said: “It is quite possible that we can do greater things than Jesus, for what is written in the Bible about him is poetically embellished.”¹⁶³⁵ Obviously, Scripture’s insistence on an Earth-centered cosmos is one idea Einstein had long ago dismissed as childish fantasy. This presupposition is noted in an address to Princeton Theological Seminary (a seminary which by this time had become very liberal in its theology, denying the inerrancy of Scripture and the literal interpretation of Genesis to make room for the theory of evolution) to which Einstein stated:

For example, a conflict arises when a religious community insists on the absolute truthfulness of all statements recorded in the Bible. This means an intervention on the part of religion into the sphere of science; this is where the struggle of the Church against the doctrines of Galileo and Darwin belongs.¹⁶³⁶

Einstein excused his immoral life as mere “stupidities” and blamed God for creating him:

I see only with deep regret that God punishes so many of his children for their numerous stupidities, for which he himself can be held responsible; in my opinion, only his nonexistence could excuse him.¹⁶³⁷

Yet Einstein would later modify his position:

In view of such harmony in the cosmos which I, with my limited human mind, am able to recognize, there are yet people who say there is no God. But what makes me really angry is that they quote me for support of such views.¹⁶³⁸

¹⁶³⁴ *Einstein: The Life and Times*, p. ix.

¹⁶³⁵ Quoted in W. Hermanns, “A Talk with Einstein,” October 1943. Einstein archive 55-285. Cited in *The Expanded Quotable Einstein*, p. 215.

¹⁶³⁶ Albert Einstein, *Ideas and Opinions*, New York, Crown Publishers, 1954, Wing Books, 1984, p. 45.

¹⁶³⁷ To Edgar Meyer, a Swiss colleague, January 2, 1915. CPAE, Vol. 8, Doc. 44, cited in *The Expanded Quotable Einstein*, Alice Calaprice, Princeton University Press, 2000, p. 201.

¹⁶³⁸ To a German anti-Nazi diplomat and author, Hubertus zu Löwenstein around 1941. Quoted in Löwenstein’s book *Towards the Further Shore* (London, 1968), p. 156. Cited in the *Expanded Quotable Einstein*, p. 214.

At times Einstein wrestled with the concept of God. In one of his later works he writes:

The idea of God in the religions taught at present is a sublimation of that old concept of the gods. Its anthropomorphic character is shown, for instance, by the fact that men appeal to the Divine Being in prayers and plead for the fulfillment of their wishes. Nobody, certainly, will deny that the idea of the experience of an omnipotent, just, and omnibeneficent personal God is able to accord man solace, help, and guidance; also, by virtue of its simplicity it is accessible to the most undeveloped mind. But, on the other hand, there are decisive weaknesses attached to this idea in itself, which have been painfully felt since the beginning of history. That is, if this being is omnipotent, then every occurrence, including every human action, every thought, and every human feeling and aspiration is also His work; how is it possible to think of holding men responsible for their deeds and thoughts before such an almighty Being? In giving out punishment and rewards He would to a certain extent be passing judgment on Himself. How can this be combined with the goodness and righteousness ascribed to Him. The main source of the present-day conflicts between the spheres of religion and of science lies in this concept of a personal God.¹⁶³⁹

This rationale for being an agnostic is ironic, in a way, since the complaint of not being able to combine God's omnipotence with man's free will comes from a man who had little problem combining the hitherto incompatible entities of space and time, energy and mass, inertia and gravity, and matter and antimatter. In fact, Einstein was known for trying always to simplify things by combining them, as he sought, although in vain, for his Unified Field Theory. As Einstein himself admits about the methodology:

¹⁶³⁹ Albert Einstein, *Out of My Later Years*, New York: Philosophical Library, 1950, p. 27; and Albert Einstein, *Ideas and Opinions*, New York, Crown Publishers, 1954, Wing Books, 1984, pp. 46-47. In his book *The World as I See It*, Einstein writes: "I cannot conceive of a God who rewards and punishes his creatures, or has a will of the kind that we experience in ourselves. Neither can I nor would I want to conceive of an individual that survives his physical death; let feeble souls, from fear or absurd egoism, cherish such thoughts. I am satisfied with the mystery of the eternity of life and with the awareness and a glimpse of the marvelous structure of the existing world, together with the devoted striving to comprehend a portion, be it ever so tiny, of the Reason that manifests itself in nature" (Citadel Press, translated by Alan Harris, 1956, 1984, originally published in 1934).

[Science] seeks to reduce the connections discovered to the smallest possible number of mutually independent conceptual elements. It is in this striving after the rational unification of the manifold that it encounters its greatest successes...¹⁶⁴⁰

So why someone who spent his whole life combining incompatible things would suddenly falter when it involved a unification between God's will and man's will, is surprising. Perhaps, with Einstein's apparent fear of being held responsible for his "deeds and thoughts" and having to face the Almighty's "reward and punishment," he is echoing the deepest motives of all men who suppress the evidence of His existence in order to make themselves autonomous.

Einstein assured his followers that he, indeed, did not believe in a personal God, and, in fact, had no religious leanings other than, perhaps, the "structure of the world."

It was, of course, a lie what you read about my religious convictions, a lie which is being systematically repeated. I do not believe in a personal God and I have never denied this but have expressed it clearly. If something is in me which can be called religious then it is the unbounded admiration for the structure of the world so far as our science can reveal it.¹⁶⁴¹

¹⁶⁴⁰ Albert Einstein, *Ideas and Opinions*, New York, Crown Publishers, 1954, Wing Books, 1984, p. 49.

¹⁶⁴¹ *Albert Einstein: The Human Side*, editors: Banesh Hoffman and Helen Dukas (Princeton University Press, 1981). In the same source, Einstein is quoted as saying: "I do not believe in immortality of the individual, and I consider ethics to be an exclusively human concern with no superhuman authority behind it." To a child who asked if scientists prayed, Einstein responded: "Scientific research is based on the idea that everything that takes place is determined by laws of nature, and therefore this holds for the action of people. For this reason, a research scientist will hardly be inclined to believe that events could be influenced by a prayer, i.e. by a wish addressed to a Supernatural Being." Einstein had a particular animosity for the Catholic Church. Another book by the same editors, *Albert Einstein: Creator and Rebel*, contains anecdotes that appear to be for the purpose of creating a cult following for Einstein. Other remarks from Einstein about God include: "Everything is determined, the beginning as well as the end, by forces over which we have no control. It is determined for the insect as well as for the star. Human beings, vegetables, or cosmic dust, we all dance to a mysterious tune, intoned in the distance by an invisible piper" (*Einstein: The Life and Times*, p. 422). In 1921 he replied to a Jewish rabbi: "I believe in Spinoza's God who reveals himself in the orderly harmony of what exists, not in a God who concerns himself with fates and actions of human beings" (*Einstein: The Life and Times*, p. 502). More to the point, Einstein writes: "I cannot conceive of a God who rewards and punishes his creatures, or has a will of the type of which we are conscious in ourselves. An individual who should survive his physical death is also beyond my comprehension, nor do I wish it otherwise; such notions are for the fears or absurd egoism of feeble souls" (*The World As I See It*, Citadel Press, 1956, 1984, p. 5); "The Jewish God is simply a negation of superstition, an imaginary result of its elimination" (*ibid.*, p. 91).

His own reasons for rejecting a personal God are stated quite clearly. Albert Einstein was a humanist who gave no credence to the divine. This is summed up in one short sentence of his: “There is nothing divine about morality, it is a purely human affair.”¹⁶⁴² He elaborates in the following paragraph:

To be sure, the doctrine of a personal God interfering with natural events could never be refuted, in the real sense, by science, for this doctrine can always take refuge in those domains in which scientific knowledge has not yet been able to set foot. But I am persuaded that such behavior on the part of the representatives of religion would not only be unworthy but also fatal. For a doctrine which is able to maintain itself not in clear light but only in the dark, will of necessity lose its effect on mankind, with incalculable harm to human progress. In their struggle for the ethical good, teachers of religion must have the stature to give up the doctrine of a personal God, that is, give up that source of fear and hope which in the past placed such vast power in the hands of priests. In their labors they will have to avail themselves of those forces which are capable of cultivating the Good, the True, and the Beautiful in humanity itself. This is, to be sure, a more difficult but an incomparably more worthy task.¹⁶⁴³

All of this, of course, reflects on Einstein’s moral life. Instead of allowing the awe-inspiring complexities of the universe to bring him to the foot of God’s throne in humble submission, science becomes the insulation to keep him away from God, and in the end, Einstein becomes his own god. In 1930 he wrote the following:

When one views the matter historically one is inclined to look upon science and religion as irreconcilable antagonists, and for a very obvious reason. The man who is thoroughly convinced of the universal operation of the law of causation cannot for a moment entertain the idea of a being who interferes in the course of events—that is, if he takes the hypothesis of causality really seriously. He has no use for the religion of fear and equally little for social or moral religion. A God who rewards and punishes is inconceivable to him for the simple reason that a man’s actions are determined by necessity, external and internal, so that in God’s eyes he cannot be responsible, any more than an inanimate object is responsible for the motions it goes through. Hence science has been charged with

¹⁶⁴² Albert Einstein, *The World As I See It*, translated by Alan Harris, Citadel Press, 1956, 1984, p. 29.

¹⁶⁴³ Albert Einstein, *Ideas and Opinions*, New York, Crown Publishers, 1954, Wing Books, 1984, p. 48.

undermining morality, but the charge is unjust. A man's ethical behavior should be based effectually on sympathy, education, and social ties and needs; no religious basis is necessary. Man would indeed be in a poor way if he had to be restrained by fear of punishment and hope of reward after death."¹⁶⁴⁴

¹⁶⁴⁴ Albert Einstein, "Religion and Science," *New York Times Magazine*, November 9, 1930; as originally stated in *The World As I See It*, p. 27. Einstein adds: "Our actions should be based on the ever-present awareness that human beings in their thinking, feeling, and acting are not free but are just as causally bound as the stars in their motion" (Statement to the Spinoza Society of America, Sept. 22, 1932. Einstein Archive 33-291, cited in *The Expanded Quotable Einstein*, p. 209).

Bibliography

- Abell, George, *Exploration of the Universe*, New York, Holt, Rinehart and Winston, 1969.
- Acel, Amir, D., *Entanglement: The Greatest Mystery in Physics*, New York, Four Walls Eight Windows, 2002.
- Adamczewski, Jan, with Edward J. Piszczek, *Nicolaus Copernicus and His Epoch*, Copernicus Society of America, Philadelphia, PA., Charles Scribners, 1974.
- Aharoni, J., *The Special Theory of Relativity*, 1965, Dover Publications, 1985.
- Airy, George Biddell, "On a supposed alteration in the amount of astronomical aberration of light produced by the passage of light through a considerable thickness of refracting medium," *Proceedings of the Royal Society*, London, 1871.
- Aiton, E. J., in "Newton's Aether-Stream Hypothesis and the Inverse Square Law of Gravitation" in *Pushing Gravity*, Matthew R. Edwards, ed., Montreal: C. Roy Keys Inc, 2002.
- Albrech, Andrea, and João Magueijo, "A Time Varying Speed of Light as a Solution to Cosmological Puzzles," *Physical Review D*, Feb. 15, 1999.
- Alfonso-Faus, Antonio, "Quantum Gravity and General Relativity Consistent with a Decreasing Speed of Light and Mach's Principle", *Substance and Spacetime*, Vol. 3, 2002, No. 3 (13).
- Alfvén, Hannes O. G., "Cosmology in the Plasma Universe: An Introductory Exposition," *IEEE Transactions on Plasma Science*, February 1990.
- Ali, Jacqueline, British Broadcasting Company News, 2004/08/06.
- Allais, Maurice, "Des régularités très significatives dans les observations interférométriques de Dayton C. Miller (1925-1926) *C. R. Academy of Science*, Paris, t. 327, Série II b, 1999.
- Allais, Maurice, "L'origine des régularités constatés dans les observations interférométriques de Dayton C. Miller (1925-1926): variations de température ou anisotropie de l'espace," *C. R. Academy of Science*, Paris, t. 1, Série IV, 2000.
- Allais, Maurice, "Nouvelles régularités très significatives dans les observations interférométriques de Dayton C. Miller (1925-1926)" *C. R. Academy of Science*, Paris, t. 327, Série II b, 1999.
- Allais, Maurice, "The Experiments of Dayton C. Miller (1925-1926) And the Theory of Relativity" *21st Century, Science and Technology*, Spring 1998.
- Allan, D. W. and D. D. Davis, M. Weiss, A. Clements, B. Guinot, M. Granveaud, K. Dorenwendt, B. Fischer, P. Hetzel, S. Aoki, M. K. Fujimoto, L. Charron, and N. Ashby, "Accuracy of International Time and Frequency Comparisons Via Global Positioning System Satellites in Common-View," *IEEE Transactions on Instrumentation and Measurement*, IM-34, No. 2, 118-125, 1985. (BIN: 689); Also in *Science*, 228: 69-70 (1985).

- Anastasowski, P. K., et al, *Foundations of Physics Letters*, 12, 579, 1999.
- Anderson, R. et al, *American Journal of Physics*, 62, 975, 1994.
- Anderson, R. and H. R. Bilger and G. E. Stedman, "The 'Sagnac' effect: a century of earth rotated interferometers," *American Journal of Physics* 62: 975-985 (1994).
- Aquinas, St. Thomas, *Summa Theologica*.
- Arago, François, "Mémoire sur la vitesse de la lumière, lu à la première classe de l'Institut, le 10 décembre 1810. *Académie des sciences* (Paris), *Comptes Rendus* 36 (1853).
- Aristotle's *De Caelo*, 295b32, cited in Karl Popper's *Conjectures and Refutations: The Growth of Scientific Knowledge*, New York, Harpers and Row, 1965.
- Aronowitz, F., ed. Monte Ross, *Laser Applications*, NY: Academic Press, 1971, vol. 1.
- Arp, Halton, *Quasars, Redshifts and Controversies*, Montreal, Interstellar Media, 1987.
- Arp, Halton, *Seeing Red: Redshifts, Cosmology and Academic Science*, Montreal, Apeiron Press, 1998.
- Arp, Halton, "The Observational Impetus for Le Sage Gravity," Max Planck Institut fur Astrophysik, 1997.
- Ashby, Neil, letter on file written to a colleague, Feb 21, 2005.
- Ashby, Neil, "Relativity and the Global Positioning System," *Physics Today*, May 2002.
- Ashby, Neil, and Bruno Bertotti, *Physical Review D* 34, 2246, 1986.
- Ashtekar and Magnon, "The Sagnac Effect in General Relativity," *Journal of Mathematical Physics*, 16, 2:341, 1975.
- Ashtekar, A., V. Husain, J. Samuel, C. Rovelli, L. Smolin: "2+1 quantum gravity as a toy model for the 3+1 theory," *Classical and Quantum Gravity* 6, L185 (1989).
- Ashtekar, A., C. Rovelli: "Connections, loops and quantum general relativity," *Classical and Quantum Gravity* 9, 3 (1992).
- Ashtekar, A., C. Rovelli, L. Smolin: "Gravitons and loops," *Physical Review D* 44, 1740, 1991.
- Aspden, Harold, *Physics Without Einstein*, Southampton, England, Sabbiton Publications, Camelot Press, Ltd., 1969.
- Aspden, Harold, *Physical Letters* 8, No. 9, (1981).
- Assis, A., *Rational Mechanics*, Apeiron, Montreal, Canada 1999.
- Athanasius, *Against the Heathen*, First Book.
- Attwood, D. K., et al, *Physical Review Letters*, 52, 1673, 1984.

Aubrey, John, *Aubrey's Brief Lives*, University of Michigan Press, 1957.

Augustine, St., *The Literal Meaning of Genesis*, translated and annotated by John Hammond Taylor, S. J., New York, Newman Press, 1982, in *Ancient Christian Writers*, ed., Johannes Quasten, *et al.*, No 41.

Augustine, *Homilies on First John*.

Babcock, L. M and R. C. Bergman, *Journal of the Optical Society of America* 54, 1:44, 1964.

Baker, Adolf, *Modern Physics and Antiphysics*, Reading, MA, Addison-Wesley Publishing Company, 1970.

Bär, Nicholas Reimers, *Fundamentals of Astronomy* [actual title: *Nicolai Raimari Ursi Dithmarsii Fundamentum astronomicum*, Strasburg, 1588.

Barbour, J. B. and B. Bertotti, "Gravity and Inertia in a Machian Framework," *Il Nuovo Cimento*, 32B(1), March 11, 1977.

Barbour, J. and H. Pfister, editors, *Mach's Principle—From Newton's Bucket to Quantum Gravity*, Boston, Birkhauser, 1995.

Barfield, Owen, *Saving the Appearances: A Study in Idolatry*, New York, Wesleyan University Press, 2nd edition, 1965, 1988.

Barnett, Lincoln, *The Universe and Dr. Einstein*, New York, New American Library, 2nd revised edition, 1957.

Barrow, John D., "Speed of Light Slowing Down," *London Sunday Times*, Nov. 15, 1988;

Barrow, John D., "Is Nothing Sacred," *New Scientist*, Vol. 163, July 24, 1999.

Barrow, John D., *The Book of Nothing: Vacuums, Voids, and the Latest Ideas about the Origins Of the Universe*, New York, Pantheon, 2000.

Barrow, J. D. and J. Levin, "The Copernican principle in compact space-times," *Monthly Notices of the Royal Astronomical Society*, December 2003, vol. 346, no. 2.

Barrow, John D., and Frank J. Tipler, *The Anthropic Cosmological Principle*, New York: Oxford University Press, 1986.

Bartocci, Umberto, *Albert Einstein E Olinto De Pretto: la vera storia della formula piu' famosa del mondo* (translated: *Albert Einstein and Olinto De Pretto, the true history of the most famous formula in the world*), Societa Editrice Andromeda, via S. Allende1, 40139.

Bartusiak, Marcia, *Einstein's Unfinished Symphony*, Joseph Henry Press, Washington, D.C., 2004.

Basil the Great, *Hexameron*.

Basil the Great, *Homilies*.

Baskin, Wade, *Albert Einstein: Letters to Solovine*, translated by Wade Baskin from the French *Lettres à Maurice Solovine*, New York: Philosophical Library, Inc, 1986.

Basu, D., "The Hubble Relation for a Comprehensive Sample of QSOs," *Journal of Astrophysics and Astronomy* (2003).

Batten, A. H., "The Barr Effect," *Journal of the Royal Astronomical Society of Canada*, 77:95, 1983.

Baughar, Joseph F., *On Civilized Stars: The Search for Intelligent Life in Outer Space*, Englewood Cliffs, NJ, Prentice-Hall, 1985.

Bayle, Pierre, *Dictionnaire historique et critique*, Desoer edition, 1820.

British Broadcasting Company, "Hubble's Deepest Shot is a Puzzle," BBC News, Sept. 23, 2004.

Beehler, R. E., R. C. Mockler and J. M. Richardon, *Meteorlogia I*, No. 3, 1965.

Beintenholtz, M. and P. Kronberg, *Astrophysics J*, LI, 287, 1984.

Bell, John Stewart, *Speakable and Unspeakable in Quantum Mechanics*, New York, Cambridge University Press, 1993.

Bell, Robert, *Impure Science: Fraud, Compromise and Political Influence in Scientific Research*, New York, John Wiley and Sons, 1992.

Berenda, "The Problem of the Rotating Disk," *Physical Review* 62:280f (1942).

Berlinski, David, "Was There a Big Bang?" *Commentary*, February 1998.

Berman, Bob, *Discover*, "Sky Lights Meet the Dark Universe," Vol. 25, No 10, October 2004.

Bernal, J. D., *Science in History*, 1st edition, London, Watts, 1954; 2nd edition, 1965.

Beth, Evert, *The Foundations of Mathematics*, New York, Harper and Row, 1966.

Bethel, Tom, "Rethinking Relativity," *The American Spectator*, April 1999.

Beyersdorf, Robert, *Giordano Bruno and Shakespeare*, Leipsic, 1889.

Biagioli, Mario, *Galileo, Courtier, The Practice of Science in the Culture of Absolutism*, The University of Chicago Press, Chicago & London, 1993.

Bible, The, Douay-Rheims version 1899.

Bilger, H. R. and G. E. Stedman, Ziyuan Li, U. Schreiber and M. Schneider, Ring lasers for geodesy, *IEEE Transactions on Instrumentation and Measurement* (special issue for CPEM/94: Conference on Precision Electromagnetic Measurements, Boulder CO, June 27-July 1, 1994) 44: 468-470 (1995).

Bilger, H.R. and G. E. Stedman, M. P. Poulton, C. H. Rowe, Li Ziyuan and P. V. Wells, "Ring laser for precision measurement of non-reciprocal phenomena," *IEEE Transactions on Instrumentation and Measurement* 42: 407-411 (1993).

Bilger, H. R. and U. Schreiber, and G. E. Stedman, "Design and application of large perimeter ring lasers," Symposium Gyro Technology, Stuttgart (Germany), 17-18 September 1996.

Bills, Bruce and Richard Ray, ("Lunar Orbital Evolution: A Synthesis of Recent Results," *Geophysical Research Letters* 26(19): 3045-3048 (October 1, 1999).

Binney, J., 1982b, *Annual Review of Astronomy and Astrophysics*, 20, 399.

Binney, J., 1981b, in *The Structure and Evolution of Normal Galaxies*, ed. S. M. Fall and D. Lynden-Bell, Cambridge: Cambridge Univ. Press.

Binney, James, *Nature*, 255:275-276, 1975.

Birch, Paul, "Is the Universe Rotating?" *Nature*, vol. 298, 29 July 1982.

Birkeland, Kristian, "The Worlds in the Universe," *Sky and Telescope*, "Birkeland and the Electromagnetic Cosmology," May 1985.

Birks, D. and S., www.babin.net.

Bjerknes, C. J., *Albert Einstein: The Incurable Plagiarist*, Downers Grove, IL, XTX Inc., 2002.

Blackwell, Basial, *A Philosophical Enquiry into the Origin of Our Ideas of the Sublime and Beautiful*, Oxford University Press, nd.

Blackwell, Richard J., *Galileo, Bellarmine, and the Bible, Including a Translation of Foscarini's Letter on the Motion of the Earth*, University of Notre Dame, Notre Dame & London, 1991.

Bodanis, David, *E=mc²: A Biography of the World's Most Famous Equation*, New York, Walker and Company, 2000.

Bohm, D., *The Special Theory of Relativity*, New York, W. A. Benjamin, 1965.

Bohm, D. and B. J. Hiley, *The Undivided Universe: An Ontological Interpretation of Quantum Mechanics*, London: Routledge, 1993.

Bondi, Hermann, "Angular Momentum of Cylindrical Systems in General Relativity," Royal Society Proceedings, Series A - Mathematical and Physical Sciences, vol. 446, no. 1926, July 8, 1994.

Bondi, Hermann, "Spherically Symmetrical Models in General Relativity," Monthly Notices of the Royal Astronomical Society, vol. 107, Nos. 5, 6, 1947.

Bondi, Hermann, *Cosmology*, Cambridge University Press, Cambridge, 1960.

Bonnor, W. B., "The Instability of the Einstein Universe," *Royal Astronomical Society*, December 9, 1954.

Bonnor, W. B., "Non-Uniform Relativistic Cosmological Model," Monthly Notices of the Royal Astronomical Society, 159, 1972.

Bordag, M., U. Mohideen and V.M. Mostepanenko, "New Developments in the Casimir Effect," *Physics Reports* 353 (2001): 1-205.

- Born, Max, *Einstein's Theory of Relativity*, New York, Dover Publications, 1962.
- Born, Max, "The Twins Paradox of Relativity," *Wireless World*, July 1981.
- Boscovich, Guiseppe, *De Determinanda Orbita Planeta ope catoptrica*, Rome 1749.
- Boscovich, Guiseppe, *Opera Pertinentia ad Opticam et Astronomiam*, Bassan, 1785.
- Bouw, Gerardus, *Bulletin of the Tychoonian Society*, No. 46, 1988.
- Bouw, Gerardus, *Bulletin of the Tychoonian Society*, No. 47, 1988.
- Bouw, Gerardus D., *Geocentricity*, Association for Biblical Astronomy, Cleveland, Ohio, 1992.
- Bouw, Gerardus, *The Geocentric Papers*, Association for Biblical Astronomy, Cleveland, Ohio, 1993.
- Brace, DeWitt Bristol Brace, "Double Refraction in Matter Moving Through the Ether," *Philosophical Magazine*, new series, 7: 317-328 (1904).
- Brans, Carl H., "Citation Classic," in *Current Contents*, March 7, 1983.
- Brans, C., and R. H. Dicke, "Mach's principle and a relativistic theory of gravitation," *Physical Review* 124 (1961).
- Brecher, Kenneth, "Is the Speed of Light Independent of the Velocity of the Source?" *Physical Review Letters*, Vol. 39, No. 17, Oct 24, 1977.
- Brehme, Robert W., "A New Look at the Ptolemaic System," *American Journal of Physics*, 44:506-514, 1976.
- Brillet and Hall, "Improved Laser Test of the Isotropy of Space," *Physical Review Letters* 42, 549-552 (1979).
- Brillet and Hall, *Physical Review Letters* 64 (1990).
- Brillouin, Leon, *Relativity Reexamined*, New York, Academic Press, 1970.
- Britt, Robert R., *Black Holes Abundant, Varied in Early Universe, Detailed Study Shows*, March 2001.
- Broad, William and Nicholas Wade, *Betrayers of the Truth*, New York: Simon and Schuster, 1982.
- Brophy, James and Henry Paolucci, eds., Introduction by Henry Paolucci, preface by Anne Paolucci, 2001, *The Achievement of Galileo*, first published by Twayne Publishers, Inc., reprinted College and University Press, 1962.
- Brown, G. Burniston, Letter to Mr. Stout, October 15, 1980, copy on file.
- Brown, G. Burniston, "A Theory of Action at a Distance," *Proceedings of the Physical Society B*, 1955, vol. 68.

- Brown, G. Burniston, "What is Wrong with Relativity," *Bulletin of the Institute of Physics and Physical Society*, 1967.
- Brown, Julian, "Faster Than the Speed of Light," *New Scientist*, April 1, 1995.
- Browne, Malcolm, *In Chile, Galaxy-Watching Robot Seeks Measure of Universe*, *New York Times*, Dec. 17, 1991.
- Browne, Malcolm W., interview of Arno Penzias appearing in *The New York Times*, March 12, 1978.
- Brown, Walt, *In the Beginning*, Phoenix, AZ, Center for Scientific Creation, seventh edition, 2001.
- Brumfiel, Geoff, "Particle no-show pans former find," *Nature*, May 6, 2004.
- Bruno, Giordano, *De Immense et Innumerabilis*, in *Opera Latina Conscripta*, ed., Fiorentino, Naples, 1884.
- Bruno, Giordano, *La Cena de le Ceneri* in *Opere Italiano*, ed., Gentile, Bari, 1907.
- Bruno, Giordano, *Spaccio de la Destia Trionphante*, cited in Dorothy Stimson, *The Gradual Acceptance of the Copernican Theory*, p. 50, from J. Lewis McIntyre, *Giordano Bruno*, London, 1903.
- Brush, C. F., *Journal of Franklin Institute*, Vol. 206, No. 1, 1928.
- Brush, C. F., *Physical Review*, vol. 31, 1928.
- Brush, C. F., Vol LXVII, No. 2, 1928.
- Brush, C. F., Vol LXVIII, No. 1, 1929.
- Brush, C. F., Vol 32, abstract, *Proceedings of the American Philosophical Society*, Vol IX No. 2, 1921.
- Brush, Charles F., "Some new experiments in gravitation," *Proceedings of the American Philosophy Society*, vol. 63, 1924.
- Brush, Stephen G., Algemeen Rijksarchief, The Hague, published by Stephen G. Brush, in *Note on the History of the Fitzgerald-Lorentz Contraction*, *Isis*, 58:231, 1967.
- Brush, Stephen G., "Why Was Relativity Accepted?" *Physics in Perspective* 1 (1999).
- Brylinski, E., "Sur la vitesse relative de la terre et de ether avoisinant." *Comptes Rendes*, 184 (1927).
- Builder, Geoffrey, *Australian Journal of Physics* 11, 1958.
- Buneman, Oscar, "A Tribute to Oscar Buneman – Pioneer of Plasma Simulation," *IEEE Transactions of Plasma Science*, February, 1994.
- Bunge, Mario, *The Myth of Simplicity*, Englewood Cliffs, New Jersey: Prentice Hall, 1963.
- Burbidge, Geoffrey, *Astrophysical Journal*, February 10, 2005.

Burke, James, *The Day the Universe Changed: How Galileo's Telescope Changed the Truth and Other Events in History That Dramatically Altered Our Understanding of the World*, New York: Little, Brown and Co., 1985.

Bursa, M., "The Sun's flattening and its influence on planetary orbits," *Bulletin of the Astronomical Institute Cze.*, 37, 5, 312-313 (1986).

Burt, E. A., *The Metaphysical Foundations of Modern Science*, Dover Publications, 2003.

Butterfield, Herbert, *The Origins of Modern Science: 1300-1800*, New York, The Free Press, 1957.

Cahill, R. T., "Absolute Motion and Gravitational Effects," *Apeiron*, 11, No. 1, 2004.

Cahill, R. T., "Quantum Foam, Gravity and Gravitational Waves," *Relativity, Gravitation, Cosmology*, editors, V. V. Dvoeglazov and A. A. Espinoza, New York: Nova Science Publication, 2004.

Cahill, Reginald T., *Novel Gravity Probe B Gravitational Wave Detection*, School of Chemistry, Physics and Earth Sciences, Flinders University, Australia, August 21, 2004.

Cahill, Reginald T., *The Einstein Postulates: 1905-2005: A Critical Review of the Evidence*, Flinders University, Adelaide, Australia, December 7, 2004.

Calaprice, Alice, *The Expanded Quotable Einstein*, Princeton University Press, 2000.

Callahan, Gene, "The History and the Pseudo-History of Science," January 25, 2005.

Campanella, O. P., Thomas, of Colabria, Richard J. Blackwell, translator, *A Defense of Galileo the Mathematician from Florence: An Inquiry as to Whether the Philosophical View Advocated by Galileo is in Agreement, or is Opposed to Sacred Scriptures*, University of Notre Dame Press, Notre Dame & London, 1994.

Campbell, L., J. C. Mc Dow, J. W. Moffat, D. Vincent, "The Sun's Quadrupole Moment and Perihelion Precession of Mercury," *Nature* 305:508, 1983.

Carrasco, L., M. Roth and A. Serrano, "Density Scaling of the Angular Momentum Versus Mass Universal Relationship," *Astronomy and Astrophysics*, 106, 89, 1982, citing Ozernoy's paper published in Russian in *Astronomicheskii Tsirkulyar*, No. 407, 1967.

Carroll, R., "Einstein's $E = mc^2$ 'was Italian's idea,'" *The Guardian*, Nov. 11, 1999.

Carter, Brandon, "Large Number Coincidences and the Anthropic Principle," M.S., Longair, editor, Dordrecht, Holland and Boston, D. Reidel Publishing Co., 1974.

Casimir, Hendrik. B. G. "On the attraction between two perfectly conducting plates," *Proceedings Koninkl. Ned. Akad. Wetenschap.* 51 (1948): 793-95.

Cedarholm, J. P., B. L. Havens, and C. H. Townes, "New experimental test of special relativity," *Physical Review Letters* 1 (1958), p 342.

- Champeney, D. C., G. R. Isaak, and A. M. Khan, "A time dilatation experiment based on the Mössbauer effect," *Proceedings of the Physical Society*, 85, 583 (1965).
- Chan, H. B., *et al*, "Nonlinear micromechanical Casimir oscillator," *Physical Review Letters* 87, 211801 (2001).
- Chandrasekhar, S., University of Chicago, *Eddington: The Most Distinguished Astrophysicist of His Time*, Cambridge University Press, Cambridge, 1983.
- Chao, Ben, NASA Space Geodesy Branch, Code 926, Goddard Space Flight, Nov. 1, 2004.
- Chappell, John, "Georges Sagnac and the Discovery of the Ether," *Archives of the International d'Histoire des Sciences*, 18:175-190, 1965.
- Chase, C. T., "A repetition of the Trouton-Noble ether drift experiment," *Physical Review*, 1927, 30, 516-519.
- Chatterjee, Bina, "Geometrical Interpretation of the Motion of the Sun, Moon and the Five Planets as Found in the Mathematical Syntaxis of Ptolemy and in the Hindu Astronomical Works," *Journal of the Royal Asiatic Society of Bengal*, 15:41-88, 1947.
- Chen, F. and U. Mohideen, "Demonstration of the lateral Casimir force," *Physical Review Letters* 88, 101801 (2002).
- Chepick, Alex M., "The Calculation of the Indispensable Accuracy of the Measuring of an EM's Wave Energy," *Spacetime and Substance*, Vol. 3, (2002), No. 3 (13).
- Chesterton, G. K., *Orthodoxy*, New York, Doubleday, 1957.
- Chiao, R. Y., and A. M. Steinberg, "Tunneling Times and Superluminality," *Progress in Optics*, vol. XXXVII, editor, Emil Wolf, Elsevier (Amsterdam: 1997), 347-406.
- Chiao, R. Y., P.G. Kwiat, and A.M. Steinberg, "Faster Than Light?" *Scientific American*, vol. 269, (no. 2): 52-60, August (1993).
- Chow, W. W., *et al*, *Review of Modern Physics*, 57, 61 (1985).
- Chown, Marcus, "Axis of Evil Warps Cosmic Background," *New Scientist*, October 22, 2005.
- Christianson, Gale E., *Edwin Hubble Mariner of the Nebulae*, Farrar-Straus-Giroux, New York, 1995.
- Christianson, Gail E., *This Wild Abyss: The Story of the Men Who Made Modern Astronomy*, Simon and Schuster, 1978.
- Chrysostom, *Homilies on Genesis* (PG 53, 57-58).
- Chrysostom, *Homilies on Titus* 2:1.
- Ciufolini, I., E. C. Pavlis. "A Confirmation of the General Relativistic Prediction of the Lense-Thirring Effect," *Nature*, 431, 958-960, October 21, 2004.
- Clark, Arthur C., *Profiles of the Future: An Inquiry into the Limits of the Possible*, New York: Holt, Rinehart and Winston, 1963, 1984.

- Clark, David and Stephen P. H. Clark, *Newton's Tyranny: The Suppressed Scientific Discoveries of Stephen Gray and John Flamsteed*, New York: W. H. Freeman and Co., 2001.
- Clark, Robert, *Nature* 202 (1964),
- Clark, Ronald W., *Einstein: The Life and Times*, Avon Books, New York, 1971, 1984.
- Clarke, Tom, *Nature Reviews*, "Gravity Leaps into Quantum World," January 17, 2002.
- Clube, Victor, "Do We Need a Revolution in Astronomy," *New Scientist*, 80:284, 1978.
- Clube, Victor, and William Napier, "Universe to Galaxy: The Cosmic Framework," *The Cosmic Serpent*, New York, 1982.
- Cochran, Adam, *Still Pitying the Fool: Why Scientists are Frauds – The Truth about our World*, San Jose, New York, Writers Club Press, 2002.
- Cohen, I. Bernard, *Birth of a New Physics*, revised and updated, New York, W. W. Norton, 1985.
- Cohen, I. Bernard, *Lives in Science*, New York: Simon and Schuster, 1957.
- Cohen, I. Bernard and Anne Whitman, *The Principia: A New Translation*, I. Bernard Cohen and Anne Whitman, University of California Press, 1999.
- "Collected Papers of Albert Einstein, The", vol. 1, Document 57, Princeton University Press, 1987.
- Collins, Graham P., "The Search for Relativity Violations," *Scientific American*, Sept. 2004.
- Connor, James A, *Kepler's Witch*, Harper Collins, 2004.
- Consoli, M. and E. Costanzo, "The Motion of the Solar System and the Michelson-Morley Experiment," Istituto Nazionale di Fisica Nucleare, Sezione di Catania Dipartimento di Fisica e Astronomia dell' Università di Catania, November 26, 2003.
- Consolmagno, S. J., Brother Guy, *Brother Astronomer: Adventures of a Vatican Scientist*, McGraw-Hill, New York, 2000.
- Cooper, Lane, *Aristotle, Galileo, and The Tower of Pisa*, Ithaca, New York, Cornell University Press, London: Humphrey Milford Oxford University Press, 1935.
- Copernicus, Nicolaus, *De revolutionibus orbium coelestium* (On the Revolutions of the Heavenly Spheres), translated by Charles Glenn Wallis, Prometheus Books, 1995
- Copernicus, Nicolaus, *Nicolai Copernici de hypothesisibus motuum coelestium a se constitutes commentariolus*, 1613.
- Corliss, William, R., *Mysterious Universe: A Handbook of Astronomical Anomalies*, The Sourcebook Project, Glen Arm, MD, 1979.
- Corliss, William, R., *Mysteries of the Universe*, New York, Thomas Y. Crowell Company, 1967.

- Corliss, William, R., *Scientific Anomalies and Other Provocative Phenomena*, The Sourcebook Project, Glen Arm, MD, 1003.
- Corliss, William, R., *Science Frontiers: Some Anomalies and Curiosities of Nature*, The Sourcebook Project, Glen Arm, MD, 1994.
- Corliss, William, R., *Stars, Galaxies, Cosmos, A Catalog of Astronomical Anomalies*, The Sourcebook Project, Glen Arm, MD, 1987.
- Corliss, William, R., *The Moon and the Planets: A Catalog of Astronomical Anomalies*, The Sourcebook Project, Glen Arm, MD, 1985.
- Corliss, William, R., *The Sun and Solar System Debris: A Catalog of Astronomical Anomalies*, The Sourcebook Project, Glen Arm, MD, 1986.
- Cornille, P., "A linear Trouton-Noble experiment which shows the violation of Newton third law," *Hadronic J. Supplement*, 1998.
- Cornille, P., "Correspondence: Making a Trouton-Noble experiment succeed," *Galilean Electrodynamics*, 1998.
- Cowen, Ron, "A Cosmic Crisis? Dark Doings in the Universe" *Science News Online*, Oct 13, 2001.
- Cowen R., "X-ray data reveal black holes galore," *Science News* 157, Jan. 15, 2000.
- Crabtree, Harold, *An Elementary Treatment of the Theory of Spinning Tops and Gyroscopic Motion*, Longmans, Green, and Co., London, 1909.
- Crease, Robert and Charles Mann, "Uncertainty and Complimentarity," *World Treasury of Physics, Astronomy and Mathematics*, editor, T. Ferris, 1991.
- Crémieu, Victor, "Recherches sur la gravitation," *Comptes Rendus de l'Académie des Sciences*, December 1906.
- Croca, J., *Nuovo Cimento B*, 114, 447, 1999.
- Crombie, A. C., *Augustine to Galileo, Volume 1: Science in the Middle Ages 5th to 13th Centuries, Volume II: Science in the Later Middle Ages and Early Modern Time, 13th to 17th Centuries*, Heinemann Educational Books, London, 1959.
- Cunningham, *The Principle of Relativity*, Cambridge University Press, London, 1914.
- Curie, Mme. Sklodowska, "Radium and Radioactivity," *Century Magazine*, January 1904.
- Custance, A. C., "The Medieval Synthesis and the Modern Fragmentation of Thought," cited in *Science and Faith*, The Doorway Papers VIII, Grand Rapids, nd.
- Dahl, Per F., *The Flash of the Cathode Rays: J. J. Thomson and His Contemporaries*, IOP Publishing, Ltd., UK, 1998.
- Darwin, George, "The Law of Redshifts," Lecture, May 1953, *Royal Astronomical Society*.

- Davies, Paul, C. W., “Cosmic Heresy?” *Nature*, 273:336, 1978.
- Davies, Paul, C. W., *God and the New Physics*, New York, Touchstone, Simon and Schuster, 1983.
- Davies, Paul, C. W., and J. Brown, *Superstrings – A Theory of Everything*, Cambridge University Press, 1998 .
- Davies, Paul, C. W. and J. R. Brown eds., *The Ghost in the Atom*, Cambridge University Press, 1986.
- Davies, Paul, C. W. personal correspondence on file.
- De Bernardis, Paolo, et al., “A flat universe from high-resolution maps of the cosmic microwave background radiation,” *Nature* 404, 955–959, 2000.
- De Bray, M. Gheury, *L’Astronomie*, *Nature* 1934.
- De Broglie, Louis, *Selected Papers on Wave Mechanics*, London: Blackie, 1928.
- De Broglie, Louis, “Waves and Particles,” *Physics Bulletin*, 22, February, 1971.
- De Chardin, Fr. Pierre Teilhard, *The Phenomenon of Man*, revised English translation by Benjamin Wall, Harper & Row, 1975.
- De Dorlodot, Canon Henri, *Darwinism and Catholic Thought*, translated by Fr. Ernest Messenger, 1922.
- De Vaucouleurs, Gerard, “The Case for a Hierarchical Cosmology,” *Science*, February 27, 1970.
- DeMeo, James, “Dayton Miller’s Ether-Drift Experiments: A Fresh Look,” 2002.
- De Oliveira-Costa, A., et al. 2004, *Physical Review D* 69 063516, as cited in *Cern Courier*, IOP Publishing, Inc, 2005.
- Derose, Noël, *If the World Only Knew: Fernand Crombette, His Life and Work*, (C.E.S.H.E., BP 1055, 59011 Lille Cedex, France, 1996.
- De Santillana, Giorgio, *The Crime of Galileo*, New York, *Time Inc.*, 1955, 1962.
- De Santillana, Giorgio and Hertha Von Dechend, *Hamlet’s Mill: An Essay Investigating the Origins of Human Knowledge and its Transmission Through Myth*, Boston, David R. Godine Publishers, 1969, 2005.
- Descartes, René, *Die Prinzipien der Philosophie*, ed. A. Buchenau, Philosophische Bibliothek, Vol. 28, F. Meiner, Hamburg, Germany, 1992.
- De Sitter, Willem, *Kosmos*, Cambridge, Harvard University Press, 1932.
- De Sitter, W., *On Einstein’s Theory of Gravitation and its Astronomical Consequences*, in *Monthly Notices*, Royal Astronomical Society, vol. lxxvi, No. 9.
- Dicke, Robert, H., *A scientific autobiography*, unpublished manuscript on file in the Membership Office of the National Academy of Sciences, 1975.

- Dicke, Robert, H., "Dirac's cosmology and Mach's principle," *Nature* 192, 1961.
- Dicke, Robert H., *Gravitation and the Universe*, American Philosophical Society, Philadelphia, 1970.
- Dicke, Robert, H. *Theoretical Significance of Experimental Relativity*, New York: Gordon and Breach, 1964.
- Dicke, Robert H., et al., "Solar Oblateness and Gravitation," *Gravitation and the Universe*, January 13, 1967, *Physical Review Letters*, 18, 313.
- Dicke, Robert H., J. R. Kuhn, K. G. Libbrecht, "Is the solar oblateness variable? Measurements of 1985," *Astrophysical Journal*, 318, 451-458 (1987).
- Dicke, R. H., J. R. Kuhn, K. G. Libbrecht, "Variable oblateness of the Sun, The: measurements of 1984," *Astrophysical Journal*, 311, 1025-1030, 1986.
- Dijksterhuis, E. J., *The Mechanization of the World Picture*, London, Oxford University Press, 1969.
- Dingle, Herbert, *Science at the Crossroads*, London: Martin Brian & O'Keeffe, 1972.
- Dingle, Herbert, *The Special Theory of Relativity*, London, Methuen & Co., New York, John Wiley and Sons, 1961.
- Dingle, Herbert, *Nature*, London 177, 782, 1956.
- Dingle, Herbert, Personal letter signed by Herbert Dingle written to Timothy O'Keeffe of Martin, Brian and O'Keeffe, Ltd., London, England, on March 20, 1972. Copy on file.
- Dingle, Herbert, Personal letter signed by Herbert Dingle written to Timothy O'Keeffe, dated October 14, 1972. Copy on file.
- Dingle, Herbert, Personal letter signed by Herbert Dingle written to Timothy O'Keeffe, dated October 26, 1972. Copy on file.
- Dingle, Herbert, Personal unsigned letter from Dingle "To the Editor of NATURE," no date given. Copy on file.
- Dirac, Paul, A. M., *Proceedings of the Royal Society A*, 117, 610 (1928a); 118, 351 (1928b).
- Dirac, Paul, A. M., *Scientific American*, May 1963.
- Dirac, Paul, A. M., *The Principles of Quantum Mechanics*. Oxford: Oxford University Press, 1930.
- Dirac, Paul, A. M., *Nature* (London): 168: 906-907 (1951).
- Dirac, Paul, A. M., *World Treasury of Physics, Astronomy and Mathematics*, ed., T. Ferris, 1991.
- Disney, M., *Science Frontiers*, No. 105: May-June 1996.

Dobrzycki, Jerzy, Editor, *The Reception of Copernicus' Heliocentric Theory: Proceedings of a Symposium Organized by the Nicolas Copernicus Committee of the International Union of the History and Philosophy of Science*, Torun, Poland, D. Reidel Publishing Company, Dordrecht-Holland/Boston U.S.A., 1972.

Donne, John, *An Anatomy of the World*, poem.

Drake, Ellen Tan, *Restless Genius: Robert Hooke and his Earthly Thoughts*, Oxford University Press, 1966.

Drake, Stillman, *Galileo*, Oxford University Press, Oxford, 1980.

Drake, Stillman, *Galileo At Work: His Scientific Biography*, Chicago, London, The University of Chicago Press, 1978.

Drake, Stillman, *Galileo: Pioneer Scientist*, University of Toronto Press, Toronto, Buffalo, London, 1990.

Drake, Stillman, *Galileo Studies Personality, Tradition and Revolution*, Ann Arbor, University of Michigan Press, 1970.

Dreyer, J. L. E., *A History of Astronomy from Thales to Kepler*, New York, Dover Publications; originally under the 1905 title: *History of Planetary Systems from Thales to Kepler*, Dublin, Ireland, Cambridge University Press, 1906.

Dreyer, J. L. E., *A History of Astronomy from Thales to Kepler*, New York, Dover Publications, reprint, 1953.

Dreyer, J. L. E., *Tycho Brahe*, New York, Dover Publications reprint, 1963.

Dubbey, J. M., *Development of Mathematics*, Crane, Russak and Co., 1970.

Dufour and Prunier, *Comptes Rendus* 204, 1925 (1937).

Dunham, David W., et al, "Observations of a Probable Change in the Solar Radius between 1715 and 1979," *Science* 210:1243, 1980.

Duncan, Ronald, and Miranda Weston-Smith, *The Encyclopedia of Ignorance*, New York, Pocket Books, 1977.

Duncan, David E., *The Calendar*, London, Fourth Estate, 1998.

Dunham, Pierre, *To Save the Phenomena: An Essay on the Idea of Physical Theory from Plato to Galileo*, University of Chicago Press, 1969.

Dyson, Eddington and Davidson, under the title: "Radial Displacement of Individual Stars," the "Report" presented to the *Royal Astronomical Society*, nd.

Eddington, Arthur, "On the Instability of Einstein's Spherical World," in *Monthly Notices of the Royal Astronomical Society*, 90 (1930).

Eddington, Arthur, *Relativity, Time and Reality*, Harold Nordenson, London, 1969.

Eddington, Arthur, "The End of the World: from the Standpoint of Mathematical Physics," *Nature*, 127 (1931).

Eddington, Arthur, *The Internal Combustion of the Stars*, England: Cambridge University Press, 1926.

Eddington, Arthur, *The Nature of the Physical World*, New York, MacMillian Company and Cambridge University Press, 1929.

Edwards, Matthew R., editor, "Gravity in the Century of Light," *Pushing Gravity: New Perspectives on Le Sage's Theory of Gravitation*, Matthew R. Edwards, ed., Montreal: C. Roy Keys Inc, 2002.

Edwards, Matthew R. "Induction of Gravitation in Moving Bodies," *Pushing Gravity*, Matthew R. Edwards, editor, Montreal: C. Roy Keys Inc, 2002.

Edwards, Matthew R. editor, "Le Sage's Theory of Gravity: The Revival by Kelvin," in *Pushing Gravity*, Montreal: C. Roy Keys Inc, 2002.

Edwards, Matthew R. editor, "Newton's Aether-Stream Hypothesis and the Inverse Square Law of Gravitation" in *Pushing Gravity*, Montreal: C. Roy Keys Inc, 2002.

Edwards, Matthew R. editor, *Pushing Gravity: New Perspectives on Le Sage's Theory of Gravitation*, Montreal: C. Roy Keys Inc, 2002.

Egbert, Gary D., and Richard D. Ray, "The Motion in the Ocean," *Nature*, July 15, 2000.

Eichenwald, A., *Annalen der Physik* 11:1, 241, 1903.

Einstein, Albert, "Dialog über Einwände gegen die Relativitätstheorie," *Die Naturwissenschaften* 6, 1918.

Einstein, Albert, "Elementary Derivation of the Equivalence of Mass and Energy," *Bulletin of the American Mathematical Society* 61, 1935; first delivered as The Eleventh Josiah Willard Gibbs Lecture at a joint meeting of the American Physical Society and Section A of the AAAS, Pittsburgh, December 28, 1934.

Einstein, Albert, "Fundamental Ideas and Methods of Relativity Theory, Present in their Development," Part II, translated from the German by Gerald Holton from Einstein's own handwriting, cited in *Thematic Origins of Scientific Thought*, Gerald, Holton, Harvard University Press, 1988.

Einstein, Albert, "Geometry and Experience," in *Sidelights on Relativity*, New York, Dover Publications, 1983.

Einstein, Albert, "Grundgedanken and Methoden der Relativitätstheorie in ihrer Entwicklung dargestellt," *Morgan Manuscript*, EA 2070, as cited in Ludwik Kostro, *Einstein and the Ether*, Aperion, 2000.

Einstein, Albert, *Ideas and Opinions*, Dell, Pinebrook, New Jersey, 1954; Wings, Reprint edition, 1988.

Einstein, Albert, Lecture at the University of Leyden, Germany, May 5, 1920.

Einstein, Albert, "Le Principe de relativité et ses consequences dans la physique moderne," *Archives de sciences physiques et naturelles*, 29.

Einstein, Albert, "Letter to H.A. Lorentz, November 15, 1919," EA 16,494 as cited in Ludwik Kostro, *Einstein and the Ether*, Aperion, 2000.

Einstein, Albert, "Letter to A. Sommerfeld, 28/11/1926," in *A. Einstein, A. Sommerfeld Briefwechsel*, Basel-Stuttgart: Schwabe u. Co. Verlag, 1968, as cited in Kostro, *Einstein and the Ether*, Aperion, 2000.

Einstein, Albert, *Out of My Later Years*, New York: Philosophical Library, 1950.

Einstein, Albert, *Relativity: The Special and the General Theory*, authorized translation by Robert W. Lawson, Three Rivers Press, New York, 1961.

Einstein, Albert, *Relativity: The Special and General Theory*, 15th edition, New York, Crown Publishers, 1961.

Einstein, Albert, "Religion and Science," *New York Time Magazine*, November 9, 1930.

Einstein, Albert, *Schweizerische naturforschende Gesellschaft, Verhandlungen*, 105 (1924).

Einstein, Albert, *Scientific American*, March 1930.

Einstein, Albert, *Sidelights on Relativity*, Dover Publications, 1983.

Einstein, Albert, *The Meaning of Relativity*, Princeton University Press, 3rd edition, 1950.

Einstein, Albert, *The World as I See It*, translated by Alan Harris, Citadel Press, 1956, 1984.

Einstein, Albert, "Über die vom Relativitätsprinzip geforderte Trägheit der Energie," *Annalen der Physik* 23 (4), 1907.

Einstein, Albert, "Über den Einfluß der Schwerkraft auf die Ausbreitung des Lichtes," *Annalen der Physik*, 35, 903f.

Einstein, Albert, "Über das Relativitätsprinzip und die aus demselben gezogenen Folgerungen," *Jahrbuch der Radioaktivität*, IV, V, (Berichtigungen), 1907.

Einstein, Albert, "Zur Elektrodynamik bewegter Körper," *Annalen der Physik*, Vol. 17, 1905.

Einstein, Albert, *Zur Enthüllung von Ernst Machs Denkmal*, n. 13.

Einstein, Albert and Leopold Infeld, *The Evolution of Physics: From Early Concepts to Relativity and Quanta*, Albert Einstein and Leopold Infeld, New York, Simon and Schuster, 1938, 1966.

Einstein, Albert and Willem de Sitter, *Proceedings of the National Academy of Sciences*, Washington, 18 [1932].

Einstein, Albert to Paul Ehrenfest, June 3, 1912, Doc. 404, 409, in Papers, vol. 5, cited in "Einstein's Investigations of Galilean Covariant Electrodynamics Prior to 1905," John D. Norton, University of Pittsburgh, Dept. of History and Philosophy of Science, Jan. 28, 2004.

- Elliger, E. et W. Rudolph, *Textum Masoreticum curavit H. P. Ruger*, Gedruckt mit Unterstützung der Deutschen Forschungsgemeinschaft 1967, 1977.
- Ellis, G. F. R., “Is the Universe Expanding?” *General Relativity and Gravitation*, vol. 9, no. 2, 1978.
- Ellis, G. F. R., *New Scientist*, May 25, 1978.
- Ellis, George, F. R., R. Maartens and S. D. Nel, “The Expansion of the Universe,” *Monthly Notices of the Royal Astronomical Society*, 184, 439-465, 1978.
- Ellis, G. F. R. and D. R. Matravers, “General Covariance in General Relativity?” in *General Relativity and Gravitation*, Vol. 27, No. 7, 1995.
- Ephrem the Syrian, *Genesim et in Exodum commentarii*, in CSCO, v. 152.
- Erasmus, Desiderius, *The Praise of Folly*, translated by J. P. Dolan, New York, New American Library, 1964.
- Eriksen, H. K., et al., 2004 *Astrophysical Journal* 605, 14.
- Essen, Louis, *Creation Research Society Quarterly*, 14:46, 1977.
- Essen, Louis, “Relativity – Joke or Swindle?” *Electronics and Wireless World*, February 1988.
- Essen, Louis, *The Special Theory of Relativity: A Critical Analysis*, London, Oxford University Press, 1971.
- Estling, Ralph, *Skeptical Inquirer*, January/February, 1995.
- Euler, Leonhard, “Réflexions sur l’espace et le temps,” *Memoir de l’academie des sciences de Berlin* 4, 324 (1748).
- Evans, James, “Gravity in the Century of Light,” in *Pushing Gravity*, Edwards, Matthew, R., ed., Montreal: C. Roy Keys Inc, 2002.
- Everett, Hugh, www.physics.fsu.edu.
- Everitt, C. W. F., “Experimental Tests of General Relativity: Past, Present and Future,” in Riazuddin, ed., *Physics and Contemporary Needs*, vol. 4, NY: Plenum, 1980.
- Falk, Dan, *Astronomy Magazine*, December 8, 2004.
- Fälthammar, Carl-Gunne, Plasma Physics from Laboratory to Cosmos – The Life and Achievements of Hannes Alfvén., *IEEE Trans. Plasma Science*, June 1997.
- Fälthammar, Carl-Gunne, *World-Antiworlds: Antimatter in Cosmology*, 1966.
- Faulkner, D. R., “Geocentrism and Creation,” *Technical Journal* 15(2):110-121, 2001.
- Favaro, Antonio, *Galileo e l’Inquisizione, Documenti de Processo Galileiano...per la prima volta integralmente publicati*, Florence, 1907.

Favaro, Antonio , *Le Opere Di Galileo Galilei*, Nuova Ristampa Della Edizione Nazionale, Sotto L'Alto Patronato Del Presidente Della Repubblica Italiana, Giuseppe Saragat, direttore: Antonio Favaro, Vol. XVIII, Firenze, G. Barbèra – Editore, 1968.

Feldhay, Rivka, *Galileo and the Church: Political Inquisition or Critical Dialogue*, Cambridge University Press, 1995.

Ferguson, Kitty, *Measuring the Universe*, New York, Walker and Company, 1999.

Ferguson, Kitty, *Tycho & Kepler: The Unlikely Partnership that Forever Changed Our Understanding of the Heavens*, New York, Walker and Company, 2002.

Ferm, Virgilius, editor, *Encyclopedia of Religion*, New Jersey, Littlefield, Adams and Co., 1959

Ferris, Timothy, *The Red Limit: The Search for the Edge of the Universe*, New York, Quill, 1983.

Ferris, Timothy, *Coming of Age in the Milky Way*, New York, Doubleday, 1988.

Feynman, Richard, “The Feynman Lectures on Physics,” Vol. 1 Reading, Massachusetts: Addison-Wesley, 1963.

Feynman, Richard P., *The Principle of Least Action in Quantum Mechanics*, Ph.D. dissertation, Princeton University, Princeton NJ.; Publication No. 2948, Ann Arbor: University Microfilms, 1942.

Feynman, Richard P., *The Strange Theory of Light and Matter*, Princeton University Press, 1988.

Feynman, Richard P., “The Theory of Positrons,” *Physical Review* 76 (1949).

Feynman, Richard P., “The Character of Physical Laws,” 1967.

Finchiaro, Maurice A., editor and translator, *The Galileo Affair: A Documentary History*, University of California Press, Berkeley, 1989.

Fischbach, E., D. Sudarsky, A. Szafer, C. Talmage and S H. Aronson, *Physical Review Letters* 56, 3, 1986.

Fischer, Klaus, *Galileo Galilei, Munich Germany*, Beck, 1983.

Fishman, G. J. and C. A. Meegan, *Annual Reviews of Astronomy and Astrophysics* 33, 415 (1995).

Fizeau, Armand, Hippolyte, Louis, “Sur les hypotheses relatives à l'éther lumineux, et sur une experience qui paraît démontrer que le mouvement des corps change la vitesse à laquelle la lumière se propage dans leur intérieur” *Académie des sciences (Paris), Comptes Rendus* 33, (1851).

Flamsteed, John, *Historia Coelestis Britannica*, 1725, ed., Allan Chapman, trans., Alison D. Johnson, National Maritime Museum Monograph, No. 52, 1982.

Folger, Tim, “Antimatter,” *Discover*, August 2004.

- Folger, Tim, "Einstein's Grand Quest for a Unified Theory," *Discover*, September 2004.
- Folger, Tim, "Nailing Down Gravity," *Discover*, October 2003.
- Fominskiy, L. P., "The Concept of an Interval: A Basic Mistake of the Theory of Relativity," *Spacetime and Substance*, Vol. 3 (2002), No. 2 (12).
- Foschini, Luigi, "Short Range Gravitational Fields: The Rise and Fall of the Fifth Force," CNR Institute, 2002.
- Fox, Karen, *The Big Bang Theory – What It Is, Where It Came from and Why It Works*, New York, John Wiley and Sons, 2000.
- Freedman, D. H., "Faster Than a Speeding Photon," *Discover*, August 1998.
- Freedman, Stuart and John Clauser, *Physical Review Letters* 28, 938, 1976.
- French, A. P., *Special Relativity*, London, Chapman and Hall, 1968.
- Friedman, Herbert, *The Amazing Universe*, National Geographic Society, 1975.
- Friedman, Alexander, "Über die Krümmung des Raumes," *Ztschr. Phys.*, 10:377-386 (1922) and 21:332-336, (1922), English translation in: *General Relativity and Gravitation*, 31 (1999), 1991-2000.)
- Friedmann, Alexander, "Über die Möglichkeit einer Welt mit konstanter negativer Krümmung des Raumes," *Z. Phys.* 21, (1924), 326-332, English translation in: *General Relativity and Gravitation* 31 (1999), 2001-2008.)
- Fresnel, Augustin, "Sur la diffraction de la lumière," 1839, *Comptes Rendus de l'Académie des Sciences*, 8, 326.
- Fresnel, Augustin Jean, "Lettre d'Augustin Fresnel à François Arago sur l'influence du mouvement terrestre dans quelques phénomènes d'optique," *Annales de chimie et de physique* 9 (1818): 57-66, 286. Reprinted in *Oeuvres Complètes*. Paris: Imprimerie impériale, 1866-1870, vol. 2.
- Fresnel, Augustin Jean, *Ann. De Chimie*, 17:180, 1821.
- Frisch, Otto, *Niels Bohr, A Centenary Volume*, editors: A. P. French and P. J. Kennedy, 1985.
- Frisch, D. and J. Smith, "Measurement of the Relativistic Time Dilation Using Mesons," *American Journal of Physics* 31 (1963) 342.
- Föppl, August, *Einführung in die Maxwellsche Theorie der Elektrizität*, Leipzig: B. G. Tuebner.
- Fourier, Joseph B. J., *Théorie analytique de al cahleur* [translated: "The Analytic Theory of Heat"], 1822.
- Gagnon, D. R., D. G. Torr, P. T. Kolen, and T. Chang, "Guided-wave measurement of the one-way speed of light," *Physical Review A* 38 no. 4 (1988).

- Galaev, Yuri M., "Ether-drift effects in the experiments on radio wave propagation," *Radiophysics and Electronics*, Institute for Radiophysics and Electronics of the National Academy of Sciences of Ukraine, Vol. 5, 2000, Ukrainian.
- Galaev, Yuri M., "Ether-drift. Experiment in the band of radio wave," Petit, Zhukovsky, 2000.
- Galaev Yuri, "Ethereal Wind in Experience of Millimetric Radiowave Propagation," *Spacetime and Substance*, Vol. 2, No. 5 (10), 2001.
- Galaev, Yuri, "Ethereal Wind in Experience of Millimetric Radiowave Propagation," *The Institute of Radiophysics and Electronics of NSA in Ukraine*, Aug. 26, 2001.
- Galaev, Yuri, "The Measuring of Ether-Drift Velocity and Kinematic Ether Viscosity Within Optical Waves Band," *Spacetime and Substance*, Vol. 3, No. 5 (15), 2002.
- Gale, George, "The Anthropic Principle," *Scientific American*, vol. 245, December 1981.
- Galilei, Galileo, *Trattato della Sfera*, Florence, Opere, Ediz. Nazionale, Vol. II, 1929.
- Galilei, Galileo, *Dialogue Concerning the Two Chief World Systems*, translated with revised notes by Stillman Drake, Berkeley, University of California Press, 1967.
- Gamov, *Physical Review*, 70:572-573 (1946).
- Gamow, George, *My World Line*, Viking Press, 1970.
- Gamow, George, *The Creation of the Universe*, New York: Viking Press, 1961.
- Gardner, Martin, *Relativity for the Million*, New York: Macmillan Co., 1962.
- Gardner, Martin, *The Relativity Explosion*, New York, Vintage Books/Random House, 1976.
- Garfinkel, Simon, "When Fraud Taints Science," *Christian Science Monitor*, July 1992.
- Gehrcke, Ernst, "Die Gegensätze zwischen der Äthertheorie und Relativitätstheorie und ihre experimentale Prüfung," *ZfP*, 4, 1923, Nr. 9.
- Gehrcke, Ernst, "Zur Kritik und Geshichte der neueren Gravitationstheorien," *AdP*, 50, 1916.
- Geller, Margaret J., John P. Huchra, of the Harvard-Smithsonian Center for Astrophysics: *Science*, November 17, 1989.
- Genet, C., A. Lambrecht and S. Reynaud, "Temperature dependence of the Casimir force between metallic mirrors," *Physical Review A* 62 012110 (2000).
- Gentry, Robert, "Creation's Tiny Mystery," 3rd edition, *Earth Science Associates*, Knoxville, Tennessee, 1992.
- Gentry, Robert, *Modern Physics Letters A* 12 (37): 2919-2925, 1997.
- Giancoli, Douglass C., *Physics: Principles with Applications*, Englewood Cliffs, New Jersey, Prentice-Hall, 1980.

- Giancoli, Douglass C., *Physics: Principles with Applications*, fourth edition, New Jersey, Prentice Hall, 1995.
- Giancoli, Douglass C., *Physics: Principles with Applications*, fifth edition, New Jersey, Prentice Hall, 1998.
- Gibbons, G.W., *Very Early Universe*, Cambridge University Press, 1983.
- Gibbs, W. Wayt, "Profile: George F. R. Ellis," *Scientific American*, October 1995, Vol. 273, No. 4.
- Gilder, Joshua and Gilder, Anne-Lee, *Heavenly Intrigue: Johannes Kepler, Tycho Brahe, and the Murder Behind One of History's Greatest Scientific Discoveries*, New York: Doubleday, 2004.
- Gilliland, Ronald L., "Solar Radius Variations over the Past 265 Years," *Astrophysical Journal*, 248:1144, 1981.
- Gilson, E., *The Philosophy of St. Bonaventure*, New Jersey, St. Anthony Guild Press, 1965.
- Gingerich, Owen, *The Book Nobody Read: Chasing the Revolutions of Nicolaus Copernicus*, New York, Walker and Co., 2004.
- Gingerich, Owen, ed., *The Nature of Scientific Discovery A Symposium Commemorating the 500th Anniversary of the Birth of Nicolaus Copernicus*, Smithsonian Institution Press, City of Washington, 1975.
- Ginzburg, V. L., *Key Problems of Physics and Astronomy*, Moscow, Mir Publishers, 1976.
- Glazebrook, Karl, press release on July 7, 2004 for John Hopkins University study.
- Gleick, James, *Genius: The Life and Science of Richard Feynman*, New York: Vintage Books, 1992, 1993.
- Goethe, Johann Wolfgang, *Zur Farbenlehre, Materialien zur Geschichte der Farbenlehre, Vierte Abteilung, Zwischenbetrachtung*, Deutscher Klassiker Verlag, Frankfurt am Main, 1991, Seite 666.
- Goldhaber and Nieto "New Geomagnetic Limit on the Mass of the Photon," *Physical Review Letters* 21:8 (1968).
- Goldsmith, Donald, *The Evolving Universe*, Menlo Park, CA, The Benjamin/Cummings Publishing Company, 1985.
- Goldstein, Herbert, *Classical Mechanics*, Addison-Wesley Publishing, Reading, MA, 2nd edition, 1980.
- Golino, Carlo Luigi, Editor, *Galileo Reappraised*, University of CA Press, Berkeley, 1960.
- Goodman, Jeremy, "Geocentrism Re-examined," Princeton University Observatory, Peyton Hall, Princeton, New Jersey, June 9, 1995.

Gorman, Gary, *The Age of the Universe: What are the Biblical Limits?* Washington, Morning Star Publications, 2005.

Gough, D. O., "Internal rotation and gravitational quadrupole moment of the Sun," *Nature*, 298, 334-339, 1982.

Gould, Stephen Jay, *Dinosaur in a Haystack: Reflections in Natural History*, New York: Harmony Books, 1996.

Gould, Stephen, "The Persistently Flat Earth," *Natural History*, March 1994.

Gould, Stephen, *Wonderful Life*, New York, W. W. Norton and Co., 1989.

Goy, F., *Foundations of Physics Letters* 10, 17, 1997.

Granek, Galina, "Einstein's Ether: Rotational Motion of the Earth," *Apeiron*, vol. 8, no. 2, April 2001.

Granek, Galina, "Einstein's Ether: Why Did Einstein Come Back to the Ether?" *Apeiron*, vol. 8, no. 3, July 2001.

Grassi, Horatio, *The Astronomical and Philosophical Balance*, nd.

Green, M. G., *Electron-Positron Physics at the Z*, "Series in High Energy Physics, Cosmology and Gravitation," Royal Holloway and Bedford College, UK, January 1998.

Greene, Brian, "A Conversation with Brian Greene," *Nova* television series, Public Broadcasting Service, October 2004.

Greene, Brian, *The Elegant Universe: Superstrings, Hidden Dimensions, and the Quest for the Ultimate Theory*, New York, W. W. Norton & Company, 1990.

Greene, Brian, *The Fabric of the Cosmos: Space, Time and the Texture of Reality*, New York, Alfred A. Knopf, 2004.

Greenstein, George, *The Symbiotic Universe: Life and Mind in the Cosmos*, New York: William Morrow, 1988.

Gregory of Nyssa, *Hexameron*.

Gregory of Nyssa, *On the Soul and the Resurrection*.

Gribbon, John, "Cosmologists Move Beyond the Big Bang," *New Scientist*, 110, No. 1511, 1986.

Gribbon, John, *In Search of Schrödinger's Cat*, New York, Bantam Books, 1984.

Gribbon, John, *Stephen Hawking: A Life in Science*, Penguin Books, 1993.

Gribbon, John, "Riddle of the Red Shift," *New Scientist*, July 9, 1994.

Grøn, Oyvind, "Relativistic Description of a Rotating Disk," *American Journal of Physics* 43, 10:869f (1975).

Guillaume, C. E., *La Nature* 24, 2, 234, 1896.

- Gurzadyan, V. G. and S. Torres, "Testing the effect of geodesic mixing with COBE data to reveal the curvature of the universe," *Astronomy and Astrophysics*, 321:19–23, 1997.
- Guth, Alan. *The Inflationary Universe*, New York: Addison-Wesley, 1997.
- Guth, Alan. "The Inflationary Universe: A Possible Solution to the Horizon and Flatness Problems," *Physical Review D* 23 (1981): 347-56.
- Guth, Alan and Paul Steinhardt, "The Inflationary Universe," *Scientific American*, May 1984.
- Gwynne, N. Martin, *Einstein and Modern Physics*, Britons Catholic Library, nd.
- Gwynne, N. Martin, *Sir Isaac Newton and Modern Astronomy*, Britons Catholic Library, nd.
- Hamar, G. W., "Velocity of Light Within a Massive Enclosure," *Physical Review*, 48 (5): 462–463, 1935.
- Hefele, J. C. and R. E. Keating, "Around-the-world atomic clocks: predicted relativistic time gains," *Science*, Vol. 177, 1972.
- Haisch, Bernard, "Brilliant Disguise: Light, Matter and the Zero-Point Field," *Science and Spirit Magazine*, 1994.
- Haisch, B and A. Rueda, "Electromagnetic Zero-Point Field as Active Energy Source in the Intergalactic Medium," presented at 35th Jet Propulsion Conference, June 1999.
- Haisch, B., A. Rueda, and H.E. Puthoff, "BEYOND $E=mc^2$: A First Glimpse of a Post-modern Physics in Which Mass, Inertia and Gravity Arise from Underlying Electromagnetic Processes," *The Sciences*, November/December, Vol. 34, No. 6, (1994).
- Haisch, B., A. Rueda, and H.E. Puthoff, "Inertia as a Zero Point Field Lorentz Force," *Physical Review A*, Vol. 49, No. 2, 1994.
- Haisch, B., A. Rueda, and H.E. Puthoff, *Physical Review A*, 49, 678 (1994).
- Haisch, B. and A. Rueda, "Electromagnetic Zero-Point Field as Active Energy Source in the Intergalactic Medium," presented at 35th Jet Propulsion Conference, June 1999.
- Haisch, B., A. Rueda and H.E. Puthoff, *The Sciences*, November/December, Vol. 34, No. 6, 1994.
- Hall, Anthea, "Sex-mad Father of Relativity left family out of equation," *London Daily Telegraph*, July 25, 1993.
- Hall, A. R., and M. Boas Hall, editors, "The Unpublished Scientific Papers of Isaac Newton," Cambridge, MA, 1962.
- Hall, Marshall, *The Earth is Not Moving*, Fair Education Foundation, Ann Arbor, Michigan, 1991, Cornelia, Georgia, 1994.
- Halliday, David and Robert Resnick, *Physics for Students of Science and Engineering*, New York, John Wiley and Sons, 1963.

- Hanes, David A., "Is the Universe Expanding?" *Nature* 289:745.
- Hanson, N. R., *Constellations and Conjectures*, Dordrecht, D. Reidel, 1973.
- Harré, Rom, *Great Scientific Experiments*, Oxford, Phaidon Press Ltd., 1981.
- Harres, Franz, "Die Geschwindigkeit de Lichtes in bewegten Korpern," Ph.D. dissertation, Univ. of Jena, Germany, 1912.
- Harrison, Edward R., *Cosmology*, Cambridge University Press, 1981.
- Harzer, P., *Astronomische Nachrichten*, 199, 337, 1914.
- Hasenöhr, F., *Annalen der Physik*, 4, 16, 589, 1905.
- Hasselbach, F. and M. Nicklaus, *Physical Review A*, 48, 143, 1993.
- Hassleberger, Josef , "Comments on gravity drop tests performed by Donald Kelly," *Nexus*, Dec. 1994 – Jan. 1995.
- Hatch, Ronald, R., *Escape from Einstein*, Kneat Company and Pacific Meridian Publishing Co., 1992.
- Hatcher, W. S., *Foundation of Mathematics*, W. B. Saunders, 1968.
- Hawkins, E., S. J. Maddox and M. R. Merrifield, "No periodicities in 2dF Redshift Survey data," *Monthly Notices of the Royal Astronomical Society*, Vol. 336, Is. 1, October 2002.
- Hawking, Stephen, *A Brief History of Time: From the Big Bang to Black Holes*, Bantam Books, New York, 1988.
- Hawking, Stephen, "Black Holes and Baby Universes", *Black Holes and Baby Universes and Other Essays*, Bantam Books, 1994.
- Hawking, Stephen, *On the Shoulders of Giants*, ed., Phila., PA, Running Press Book Publishers, 2002.
- Hawking, S. W. And Ellis, G. F. R., *The Large Scale Structure of Space-Time*, Cambridge University Press, Cambridge, 1973.
- Hawking, Stephen and Leonard Mlodinow, *A Briefer History of Time*, New York, Bantam-Dell Books, 2005.
- Hayden, Deborah, *Pox: Genius, Madness and the Mysteries of Syphilis*, Basic Books, 2003.
- Hayden, Deborah, "Syphilis in the Einstein Factory," from June 17, 2005 letter from Hayden on file, used with permission.
- Hayden, Howard, C., "Analysis of Trouton-Noble experiment," *Galilean Electrodynamics*, Vol. 5, No. 4, 1994.
- Hayden, Howard, C., "High sensitivity Trouton-Noble experiment," *Review Scientific Instruments*, Vol. 65, No. 4, 1994.

- Hayden, Howard C. and Cynthia K Whitney, "If Sagnac and Michelson-Gale Why Not Michelson-Morley?" *Galilean Electrodynamics*, vol. 1, no. 6, Tufts University, Nov./Dec. 1990.
- Hazelett, Richard, and Dean Turner, *The Einstein Myth and the Ives Papers: A Counter-Revolution in Physics*, Greenwich, CT, Devin-Adair Co. publishers, 1979.
- Heath, Thomas, *Aristarchus of Samos: The Ancient Copernicus*, Oxford, Clarendon Press, 1913.
- Hecht, Laurence, *21st Century Science*, Spring 2001.
- Heilbron, J. L., *The Sun in the Church: Cathedrals as Solar Observatories*, Harvard University Press, 1999.
- Heisenberg, Werner, Letter to Wolfgang Pauli, February 8, 1934.
- Heisenberg, Werner, *Physics and Beyond, Physics and Beyond*, translated by Arnold J. Pomerans, New York: Harper, 1971. Original in German is titled *Der Teil und das Ganze*, München: Piper, 1969.
- Heisenberg, Werner, *Physics and Philosophy: The Revolution in Modern Science*, New York, Harper and Row, 1966.
- Hellman, Hal, *Great Feuds in Science*, New York, John Wiley and Sons, 1998.
- Henderson, R. L., *The Return of Common Sense: The Demise of Relativity*, Common Sense Publishers, 1992.
- Herbert, Nick, *Quantum Reality: Beyond the New Physics: An Excursion into Metaphysics and the Meaning of Reality*, New York, Anchor Books, Doubleday, 1987.
- Herneck, Friedrich, "Zum Briefwechsel Albert Einsteins mit Ernst Mach," *Forschungen und Fortschritte*, 37:239-243, 1963.
- Heyl, Paul R., "The History and Present Status of the Physicist's Concept of Light," in "Proceedings of the Michelson Meeting of the Optical Society of America," vol. XVIII, nos. 1-6, March 1929.
- Hicks, W. M., "On the Michelson-Morley Experiment Relating to the Drift of the Aether," *Philosophical Magazine*, Series 6, 3, 1902.
- Highfield, Robert and Paul Carter, *The Private Lives of Albert Einstein*, New York, St. Martins Press, 1993.
- Hils, Dieter, and J. L. Hall, "Improved Kennedy-Thorndike Experiment to Test Special Relativity," *Physical Review Letters* 64 (1990), p 1697.
- Hildegard, von Bingen, *Die göttlichen Werke*.
- Hildegard, von Bingen, *Ursachen u. Behandlung der Krankheiten*.
- Hildegard, von Bingen, *Welt und Mensch*.
- Hilton, David, "Antimatter," *Discover*, August 2004.

- Hirshfeld, Alan W., *Parallax: The Race to Measure the Universe*, New York, W. H. Freeman and Co, 2001.
- Hoek, Martinus, "Determination de la vitesse avec laquelle est entraînée une onde lumineuse traversant un milieu en mouvement," *Arch. Neerl.*, 1868, 3; and 1869, 4.
- Hoffman, Banesh, *Albert Einstein, Creator and Rebel*, London, Granada Publishing, 1979.
- Hoffman, Banesh and Helen Dukas, editors, *Albert Einstein: Creator and Rebel*, Princeton University Press, 1981.
- Hoffman, Banesh and Helen Dukas, editors, *Albert Einstein: The Human Side*, Princeton University Press, 1981.
- Hogan, James P., *Kicking the Sacred Cow*, New York, Baen Publishing Enterprises, 2004.
- Holding, S. C., and G. J. Tuck "A New Mine Determination of the Newtonian Gravitational Constant," *Nature*, Vol. 307, Feb. 1984.
- Holton, Gerald, "On the Origins of the Special Theory of Relativity," *American Journal of Physics*, Vol. 28, 1960.
- Holton, Gerald, *Thematic Origins of Scientific Thought*, Harvard University Press, 1988.
- Holton, Gerald and Stephen G. Brush, *Introduction to Concepts and Theories in Physical Science*, Reading, MA, Addison-Wesley Publishing Co., 1973.
- Honorius of Autun, *Hexameron*.
- Hooft, Gerald 't, *Salamfestschrift*, editors, A. Ali, J. Ellis and S Randjbar-Daemi, World Scientific, Singapore, 1993.
- Hooke, Robert, *An Attempt to Prove the Motion of the Earth by Observation*, London, 1674 as reproduced in *Early Science in Oxford* by R. T. Gunther, Oxford University Press, 1930, ref. 1, Vol. vii.
- Hooke, Robert, Lecture given to the Royal Society titled *Planetary Movements as a Mechanical Problem*, on May 23, 1666, as reproduced in *Early Science in Oxford* by R. T. Gunther, Oxford University Press, 1930, ref. 1, Vol. vi.
- Horgan, John, *Scientific American*, "Profile: Fred Hoyle: The Return of the Maverick," March 1995.
- Horgan, John, Interview with, cited in *The End of Science*, New York, Broadway Books, 1996.
- Horgan, John, *The End of Science: Facing the Limits of Knowledge in the Twilight of the Scientific Age*, New York: Broadway Books, 1997.
- Hotson, D. L., "Dirac's Equation and the Sea of Negative Energy" *Infinite Energy*, Issue 43, 2002.

- Hoyle, Fred, *A Different Approach to Cosmology*, England: Cambridge, University Press, 2000.
- Hoyle, Fred, "A New Model for the Expanding Universe," *Royal Astronomical Society*, 108, 1948.
- Hoyle, Fred, *Astronomy and Cosmology*, San Francisco, W. H. Freeman and Co, 1975.
- Hoyle, Fred, in *Frontiers of Astronomy*, New York: Harper and Row, 1963.
- Hoyle, Fred, *Nicolaus Copernicus: An Essay on his Life and Work*, New York: Harper and Row Publishers, 1973.
- Hoyle, Fred, *The Nature of the Universe*, Oxford University Press, 1952.
- Hoyle, Fred, *The Quasar Controversy Resolved*, University College Cardiff Press, 1981.
- Hoyle, Fred, "The Universe: Past and Present Reflections," *Annual Reviews of Astronomy and Astrophysics*, 20 (1982).
- Hoyle, Fred and Chandra Wickramasinghe, *Evolution From Space*, New York, Simon and Schuster, 1981.
- Hubble, Edwin, "A Relation Between Distance and Radial Velocity Among Extra-Galactic Nebulae," *Proceedings of the National Academy of Science*, 15, 1929.
- Hubble, Edwin, *Astrophysical Journal* 84, 517, 1936.
- Hubble, Edwin, *Monthly Notices of the Royal Astronomical Society*, 17, 506, 1937.
- Hubble, Edwin, "Redshifts in the Spectra of Nebulae," *The Halley Lecture*, May 8, 1934, Oxford, Clarendon Press, 1934.
- Hubble, Edwin, *The Observational Approach to Cosmology*, Oxford, Clarendon Press, 1937.
- Hubble, Edwin, "The Problem of the Expanding Universe," *American Scientist*, Vol. 30, No. 2, April 1942,
- Hubble, Edwin, *The Realm of the Nebulae*, Yale University Press, 1936.
- Hubble, Edwin and Milton Humason, "The Velocity-Distance Relation Among Extra-Galactic Nebulae," *Astrophysical Journal*, 74, 1931.
- Hubble, Edwin and Richard Tolman, "Two Methods of Investigating the Nature of the Nebular Redshift," *Astrophysical Journal*, 82:302-37, 1935.
- Hughes, David W., "Solar Size Variation," *Nature* 286:439, 1980.
- Humason, Milton, "Velocity-Distance Relation Among Extra-Galactic Nebulae," *Astrophysical Journal*, 74, 1931.
- Humason, Milton, "The Apparent Radial Velocities of 100 Extra-Galactic Nebulae," *Astrophysical Journal*, 83, 1936.

Humphreys, D. Russell, "Our galaxy is the center of the universe, quantized-redshifts show," *Technical Journal* 16 (2).

Humphreys, D. Russell, *Starlight and Time: Solving the Puzzle of Distant Starlight in a Young Universe*, Green Forest, Arkansas, Master Books, 1994.

Huxley, T. H., *Letters and Diary 1885*, November 12, 1885.

Ibadova, Umida, "Spontaneous Breaking of Symmetry and Fundamental Mass," Dept. of Theoretical Physics, Samarkand, Uzbekistan.

Illingworth, K. K., "A repetition of the Michelson-Morley experiment using Kennedy's refinement," *Physical Review*, 30, 692-696, 1926.

Irion, Robert, "The Warped Side of Dark Matter," *Science*, 300: 1894, June 22, 2003.

Ives, Herbert, and G. R. Stilwell, "Light Signals on Moving Bodies as Measured by Transported Rods and Clocks" *Journal of the Optical Society of America*, July 1937, vol. 27.

Ives, Herbert, and G. R. Stilwell, "Light Signals Sent Around a Closed Path" in the *Journal of the Optical Society of America*, April 16, 1938, Vol. 28.

Ives, Herbert, "Measurement of the Velocity of Light by Signals Sent in One Direction, The," *Journal of the Optical Society of America*, Oct. 1948, vol. 38, no. 10.

Ives, Herbert, "Historical Note on the Rate of a Moving Clock," *Journal of the Optical Society of America*, Oct. 1947, vol. 37, no. 10.

Ives, Herbert, *Journal of the Optical Society of America*, 29:183-187, 1939.

Ives, Herbert, *Journal of the Optical Society of America* 38: 879-884, 1948.

Ives, Herbert, *Journal of the Optical Society of America* 27: 263-273, 1937.

Ives, Herbert, *Proceedings of the American Philosophical Society* 95: 125-131, 1951.

Ives, Herbert, "Revisions of the Lorentz Transformations," *Proceedings of the American Philosophical Society*, vol. 95, no. 2, April, 1951.

Iwasaki, J., C. Rovelli: "Gravitons from loops: non-perturbative loop-space quantum gravity contains the graviton-physics approximation," *Classical and Quantum Gravity* 11, 1653, 1994.

Jaakkola, Toivo, "Action-at-a-Distance and Local Action in Gravitation," in *Pushing Gravity*, Edwards, Matthew R. ed., Montreal: C. Roy Keys Inc, 2002.

Jaffe, Bernard, *Michelson and the Speed of Light*, Garden City, New York, Doubleday and Company, 1960.

Jaki, Stanley, *Bible and Science*, Christendom Press, 2004.

Jaki, Rev. Stanley L., *Genesis 1 Through the Ages*, London, Thomas More Press, 1992.

Jammer, M., "John Stewart Bell and the Debate on Significance of his Contributions to the Foundations of Quantum Mechanics," in *Bell's Theorem and the Foundations of*

Modern Physics, eds. A. Van der Merwe, F. Felleri, G. Tarozzi, Singapore, New Jersey, World Scientific, 1992.

Janssen, Michel, "A comparison between Lorentz's ether theory and special relativity in the light of the experiments of Trouton and Noble," Ph.D. thesis, 1995.

Janssen, Michel, "The Einstein-Besso Manuscript: A Glimpse Behind the Curtain of the Wizard," Fall 2002.

Janssen, Michael, "The Einstein-De Sitter Debate and Its Aftermath," University of Minnesota, class handout, nd..

Janssen, Michael, "What Did Einstein Know and When Did He Know It?: A Besso Memo Dated August 1913," nd.

Jaseja, T. S., A. Javan, J. Murray and C. H. Townes, "Test of Special Relativity or of the Isotropy of Space by use of Infrared Masers," *Physical Review* 1, 133a: 1221-1225, 1964.

Jaseja, T. S., et al., "Measuring ether drift à la Michelson-Morley with an interference experiment," *Physical Review* 133 (1964), p. A 1221.

Jeans, James, *Astronomy and Cosmogony*, 2nd edition, Cambridge University Press, 1929.

Jefimenko, Oleg D., "The Trouton-Noble paradox," *Journal of Physics A*. 32, 3755–3762, 1999.

Jenkins, Francis and Harvey White, *Fundamentals of Optics*, New York: McGraw Hill, 1957.

Jerome, *Letters*, 124, To Avitus.

Joos, Georg, "Die Jenaer Wiederholung des Michelsonversuchs," *Annalen der Physik S.* 5, vol. 7, No. 4, 1930.

Joos, Georg, *Theoretical Physics* (1934), third edition, London, Blackie, 1958.

Joos, Georg, and Dayton Miller, Letters to the Editor, *Physical Review*, Vol.45, p.114, 15 Jan. 1934.

Jones, B. E., *Astronomical Journal*, 1976, 81:455.

Jones, Neville, T., "Stellar Distances and the Age of the Universe," private paper, nd.

Judson, Horace F., *The Great Betrayal: Fraud in Science*, Harcourt, Inc., Orlando, Florida, 2004.

Kagan, B. A. and Maslova, N. B., "A stochastic model of the Earth-Moon tidal evolution accounting for the cyclic variations of resonant properties of the ocean: An asymptotic solution," *Earth, Moon and Planets* 66: 173-188 (1994).

Kane, Gordon, *The Particle Garden: Our Universe as Understood by Particle Physicists*, New York: Addison-Wesley, 1995.

Kant, Immanuel, "Critique of Pure Reason," *Great Books of the Western World*, vol. 42, editor, Robert Maynard Hutchins, Chicago: Encyclopedia Britannica, 1952.

Kant, Immanuel, "Metaphysische Anfangsgründe der Naturwissenschaft," *Schriften zur Naturphilosophie*, Werkausgabe Band IX, editor, W. Weischedel, Suhrkamp, Frankfurt, 1968.

Kant, Immanuel, *Religion Within Limits of Pure Reason Alone*, translated by T. M. Green and H. H. Hudson, New York: Harper and Row, 1960.

Kant, Immanuel, *Universal Natural History and Theory of the Heavens, Theories of the Heavens*, editor, Milton K. Munitz, Glencoe, IL: Free Press, 1957.

Kantor, W., *Journal of the Optical Society of America*, vol. 52, no. 8.

Kantowski, Ronald, "The Coma Cluster as a Spherical Inhomogeneity in Relativistic Dust," *The Astrophysical Journal*, vol. 155, March 1969.

Kaplan, Morton F., Editor, *Homage to Galileo: Papers Presented at the Galileo Quadricentennial University of Rochester Oct. 8 & 9, 1964*, Massachusetts Institute of Technology, 1965.

Karlsson, "Possible discretization of quasar redshift," *Astronomy and Astrophysics*, 13:333, 1971.

Katz, Jonathan I., *The Biggest Bangs: The Mystery of Gamma-Ray Bursts, The Most Violent Explosions in the Universe*, Oxford University Press, 2002.

Kelly, Alphonsos G., "Hefele & Keating Tests; Did They Prove Anything?" HDS Energy Ltd., Celbridge, Co. Kildare, Ireland, nd.

Kendall, D. and G. A. Young, *Monthly Notices of the Royal Astronomical Society*, 207, 637, 1984.

Kennedy, Barbara, "Strong New Evidence of a New, Supersolid Phase of Matter," *Science Journal*, Penn State University, Summer 2005.

Kennedy, R. J., "Conference on the Michelson-Morley Experiment held at Mount Wilson Observatory," Feb 4-5, 1927 in *The Astrophysical Journal* 68, 1928.

Kennedy, R. J., "A Refinement of the Michelson-Morley experiment," *Proc. National Academy of Science*, 12, 621-629, 1926.

Kennedy, R. J. and E. M. Thorndike, *Experimental Establishment of the Relativity of Time*, *Physical Review* 42, 1932, 400-432.

Kepler, Johannes, *Apologia Tychonis contra Ursum*, published in the Kepler's *Opera Omnia*, editor, Frisch, I.

Kepler, Johannes, *Gesammelte Werke*, "Band I Mysterium Cosmographicum De Stella Nova", C.H. Beck'sche Verlagsbuchhandlung, München MCMXXXX.

Kepler, Johannes, *Gesammelte Werke*, "Band VI Harmonice Mundi", C.H. Beck'sche Verlagsbuchhandlung, München MCMXXXX.

- Kepler, Johannes, *Harmonice Mundi*, Lib. IV, Casper's Biography, I., *Gesammelte Werke*, vol. Vi.
- Kepler, Johannes, *Johann Kepler, 1571-1630, A Tercentary Commemoration of His Life and Work: A Series of papers Prepared Under the Auspices of the History of Science Society*, The Williams & Wilkins Company, composed & printed at the Waverly Press, Inc., 1931.
- Kepler, Johannes, *Letter to D. Fabricius*, February 1604, *Gesammelte Werke*, vol. xv.
- Kepler, Johannes, *Letter to Michael Maestlin*, October 3, 1595, *Gesammelte Werke*, vol. xiii.
- Kepler, Johannes, *Letter to Michael Maestlin*, February 16, 1599, *Gesammelte Werke*, vol. xiii.
- Kepler, Johannes, *On the Motion of Mars*, Prague, 1609.
- Kesten, Hermann, Hugo Steiner-Prag Illus., *Copernicus and His World*, Roy Publishers, New York, 1945.
- Keswani, G. H., "Origin and Concept of Relativity," *British Journal of the Philosophical Society*, 15:286-306, 1965.
- Kierien, John, "Gravitation as a Compton Effect Redshift," in *Pushing Gravity*, Matthew R. Edwards, ed., Montreal: C. Roy Keys Inc, 2002.
- Kierien, John, "Implications of the Compton Effect Interpretation of the Redshift," *IEEE Transactions of Plasma Science* 18, 61, 1990.
- King, Henry C., *Gearred to the Stars: The Evolution of Planetariums, Orreries and Astronomical Clocks*, University of Toronto Press, 1978.
- King, Ivan, *The Evolution of Galaxies and Stellar Populations*, editors, B. M. Tinsley and R. B. Larson, New Haven: Yale University Observatory, 1977.
- Kirshner, R., "Deep Redshift Survey of Galaxies Suggest Million-MPC3 Void," *Physics Today*, 35:17-19, January 1982.
- Kline, Morris, *Mathematics and the Physical World*, Dover Publications, 1981.
- Kline, Morris, *Mathematics and the Search for Knowledge*, Oxford University Press, 1986.
- Kline, Morris, *Mathematics in Western Culture*, Oxford University Press, 1953.
- Kline, Morris, *Mathematics: The Loss of Certainty*, Oxford University Press, Oxford, 1981, New York, 1982.
- Klinkerfues, Ernst, *Die Aberration der Fixsterne nach der Wellentheorie*. Leipzig: Von Quandt and Händel, 1867.
- Knowles, S. H., et al, "Spectra, Variability, Size, and Polarization of H₂O Microwave Emission Sources in the Galaxy," *Science*, March 7, 1969.
- Koestler, Arthur, *Lives in Science*, New York: Simon and Schuster, 1957.

- Koestler, Arthur, "The Greatest Scandal in Christendom," *The Critic*, October-November, 1964.
- Koestler, Arthur, *The Sleepwalkers: A History of Man's Changing Vision of the Universe*, Peilican Books Ltd., England, 1959, reprinted 1979.
- Kohn, Alexander, *False Prophets*, Oxford, Basil Blackwell Ltd., 1986.
- Kolen, P. and D. G. Torr, "An Experiment to Measure the One-Way Velocity of Propagation of Electromagnetic Radiation," *Foundations of Physics* 12, 401-411, 1982.
- Koo, D., and R. Krone, *Annual Review of Astronomy and Astrophysics*, 30, 613, 1992.
- Kostelecký, Alan, "The Search for Relativity Violations," *Scientific American*, Sept. 2004.
- Kostro, Ludwik, *Einstein and the Ether*, Aperion, 2000.
- Kostro, Ludwik, "Einstein and the Ether," *Electronics and Wireless World*, 94:238-239, 1988.
- Koyré, Alexandre, *From the Closed World to the Infinite Universe*, Johns Hopkins University Press, 1968.
- Koyré, Alexandre, "Galileo and Plato," *Journal of the History of Ideas*, vol. 4, no. 4, Oct. 1943.
- Koyré, Alexander, translated by John Mepham, *Galileo Studies*, Humanities Press, New Jersey, 1978.
- Koyré, Alexandre, "Traduttore-Traditore. A Propos de Copernic et de Galilée," *Isis*, 34, 209-210, 1943.
- Koyré, Alexandre, *Metaphysics and Measurement: Essays in Scientific Revolution*, Harvard University Press, Cambridge, 1968.
- Krasinski, Andrzej, *Inhomogeneous Cosmological Models*, University of Cambridge Press, 1997.
- Krasinski A and C. Hellaby, "Structure Formation in the Lemaître-Tolman model," *Physical Review*, D65 023501, 2002.
- Kraus, Gerhard, *Physics or Metaphysics*, Janus Publishing Company, London, 1998.
- Krauss, Lawrence M., "Questions That Plague Physics," *Scientific American*, Sept. 2004.
- Krauss, Lawrence M., *Hiding in the Mirror: The Mysterious Allure of Extra Dimensions from Plato to String Theory and Beyond*, New York, Viking, 2005.
- Kruglinski, Susan, "Hunting of the First Stars," *Discover*, February 2006.
- Kuhn, J. R., K. G. Libbrecht, "Oblateness of the Sun in 1983 and Relativity," *Nature*, 316, 687-690, 1985.

Kuhn, Thomas S., *The Copernican Revolution: Planetary Astronomy in the Development of Western Thought*, New York: Random House, 1959.

Kuhn, Thomas, S., *The Structure of Scientific Revolutions*, 3rd edition, University of Chicago Press, 1996.

Kunzig, Robert, *Discover* contributing editor, "The Master's Mistakes," September 2004.

Kunzig Robert, *Discover* contributing editor, "Testing the Limits of Einstein's Theories," September 2004.

Lactantius, *The Divine Institutes*, Book 3, Chapter 23.

Lakatos, Imre, *The Methodology of Scientific Research Programmes: Philosophical Papers*, edited by J. Worrall and G. Currie, Vol. 1, Cambridge University Press, 1978, 1999.

Lakatos, Imre and Elie Zahar, "Why Did Copernicus' Research Program Supersede Ptolemy's," *The Copernican Achievement*, editor, Robert S. Westman, University of California Press, 1975.

Lakes, "Experimental limits on the Photon Mass and Cosmic Magnetic Vector Potential," *Physical Review Letters* 80:9, 1998.

Lamoreaux, K., "Demonstration of the Casimir force in the 0.6 to 6 micrometer range," *Physical Review Letters* 78 5, 1997.

Lamoreaux, S., *Physical Review Letters*, 78, 1996.

Langevin, Paul, *Comptes Rendus* 173, 1921.

Larmor, "On the dynamics of radiation," *Proceedings of the International Congress on Mathematics*, Cambridge, 1912.

Larmor, J. J., *Aether and Matter*, Cambridge, 1900.

La Rosa, *Phys. Zeitschrift* 13:1129, 1912.

Larson, Dewey B., "Globular Clusters," *The Universe in Motion*, North Pacific Publishers, Portland, Oregon, 1984.

Latham, R. and J. Last, *Proceedings of the Royal Society of London*, A320, 131, 1970.

Laughlin, Robert B., *A Different Universe: Reinventing Physics from the Bottom Down*, New York, Basic Books, 2005.

Lear, John, *Kepler's Dream*, Berkeley, University of California Press, 1965.

Lederman, Leon M. and Christopher T. Hill, *Symmetry and the Beautiful Universe*, Amherst, New York, Prometheus Books, 2004.

Leibniz-Clarke Correspondence, 5th paper, Manchester University Press, England, 1956.

- Lemaître, Georges, A., "A Homogeneous Universe of Constant Mass and Increasing Radius Accounting for the Radial Velocity of Extra-Galactic Nebulae," *Royal Astronomical Society*, 91, 1931, translated from the original French paper published in 1927.
- Lemaître, Georges, A., *The Expanding Universe*, 1933 Ann. Soc. Sci Bruxelles A53 51 (French), reprinted in 1997 in *General Relativity and Gravitation*, 29, 641;
- Lemaître, Georges, *The Primeval Atom: An Essay on Cosmogony*, translated by Betty and Serge Korff, New York: D. Van Nostrand, 1950.
- Lenard, P. H., *Über Äther und Uräther*, Leipzig, Verlag von S. Kitzel, 1921.
- Lenard, P. H., *Über Energie und Gravitation*, Berlin/Leipzig, Walter de Gruyter und Co., 1929.
- Lenard, P. H., "Über Relativitätsprinzip, Äther, Gravitation," Leipzig, S. Hirzel, 1918.
- Lenard, P. H., "Allgemeine Diskussion über Relativitätstheorie," *Physikalische Zeitschrift*, 1920.
- Lense, Joseph and Thirring, Hans, Über den Einfluss der Eigenrotation der Zentralkörper auf die Bewegung der Planeten und Monde nach der Einsteinschen Gravitationstheorie. *Physikalische Zeitschrift* 19, 156-163 (1918), translated as: "On the Influence of the Proper Rotation of Central Bodies on the Motions of Planets Moons According to Einstein's Theory of Gravitation."
- Lerner, Eric, in "An Open Letter to the Scientific Community," *New Scientist*, May 22, 2004.
- Lerner, Eric, *The Big Bang Never Happened*, New York, Random House, 1991.
- Letters to the Editors, *Scientific American*, March 1995.
- Lévy, Joseph, *From Galileo to Lorentz...and Beyond*, Apeiron, Roy C. Keys, 2003.
- Lévy, Joseph, "Hidden Variables in Lorentz Transformation," P. I. R. T., 1998.
- Lévy, Joseph, "How the Apparent Speed of Light Invariance Follows from Lorentz Contraction," France, unpublished, nd.
- Lévy, Joseph, "Some Important Questions Regarding Lorentz-Poincare's Theory and Einstein's Relativity," P. I. R. T., 1996.
- Lewis, C. S., *Studies in Medieval and Renaissance Literature*, Cambridge University Press, 1966.
- Lewis, C. S., *The Discarded Image*, Cambridge University Press, 1964.
- Lewis, C. S., *The Pilgrim's Regress*, Grand Rapids, W. B. Erdmans, 1958.
- Lewontin, Richard, "Billions and Billions of Demons," *The New York Review of Books*, January 9, 1997.
- Liddell and Scott, *Greek-English Lexicon*, Oxford University Press, 1871, 1977.

- Linde, Andrei, "The Self-Producing Inflationary Universe," *Scientific American*, Magnificent Cosmos, 1998.
- Livingston, Dorothy M., *The Master of Light: A Biography of Albert A. Michelson*, Scribners, 1973.
- Livio, Mario, *The Golden Ratio: The Story of Phi, The World's Most Astonishing Number*, New York, Random House, 2002.
- Lodge, Oliver, *My Philosophy*, London, Ernest Benn, 1933.
- Logde, Sir Oliver, "On Aberration Problems," *Philosophical Transactions of the Royal Society*, London, 189, 149, 1897.
- Lodge, Oliver, *Philosophical Transcripts of the Royal Society*, London 184: 727-804, 1893.
- Lodge, Oliver, "On the Present State of Knowledge of the Connection between Ether and Matter: A Historical Summary," *Nature*, 46:164-165, 1892.
- Lodge, Oliver, "Popularity Relativity and the Velocity of Light," *Nature*, vol. CVI, November 4, 1920.
- Lodge, Oliver, *The Ether of Space*, Harper and Brothers, New York and London, 1909.
- Lombard, Peter, *Lombardi opera omnia*, PL 192, 651.
- London Daily Telegraph*, cited in *The Washington Times*, 3-24-2003.
- London Daily Telegraph*, October 30, 1996.
- London Daily Telegraph*, September 1997.
- Long, D. R., "Experimental Examination of the Gravitational Inverse Square Law," *Nature*, April 1976, Vol. 260.
- Long, D. R., "Why Do We Believe Newtonian Gravitation at Laboratory Dimensions?" *Physical Review D* 9, 1974.
- Longair, M. S., editor, "Confrontation of Cosmological Theories with Observational Data," Dordrecht, Holland and Boston, D. Reidel Publishing Co., 1974.
- Lopez-Corredoira, M., and C. Gutierrez, *Astronomy and Astrophysics*, 2002, 390.
- Lorentz, Henrick, *Astrophysical Journal*, 68, 350, 1928.
- Lorentz, Henrick, A., editor, "Space and Time", *The Principle of Relativity*, Dover Publications, 1952.
- Lorentz, Henrick, A., and A. Einstein, H. Minkowski, H. Weyl, "Electromagnetic Phenomena in a System Moving with any Velocity Less Than that of Light," *The Principle of Relativity: A Collection of Original Memoirs on the Special and General Theory of Relativity*, translated by W. Perrett and G. B. Jeffery, Dover Publications, 1923.

Lorentz, Hendrik, A., and A. Einstein, H. Minkowski, H. Weyl, "Space and Time," *The Principle of Relativity: A collection of Original Memoirs on the Special and General Theory of Relativity*, translated by W. Perrett and G. B. Jeffery from the original 1923 edition, Dover Publications, 1952.

Lorentz, Hendrik, "De relatieve beweging van de aarde en den aether" reprinted as "The Relative Motion of the Earth and the Ether," 1886.

Lorentz, Hendrik, "La theorie electromagnétique de Maxwell et son application aux corps mouvants," *Archives néerlandaises des sciences exactes et naturelles* 25, 1892.

Lorentz, Hendrik, "On the Influence of the Earth's Motion of Luminiferous Phenomena," 1886.

Lorentz, Hendrik, "Over den invloed, dien de beweging der aarde op de lichtverschijnselen uitoefent," *Koninklijke Akademie van Wetenschappen (Amsterdam); Afdeling Natuurkunde, Verslagen en Mededeelingen* 2 (1885-86): 297-372. Reprinted: "De l'influence du mouvement de la terre sur les phénomènes lumineux," *Archives néerlandaises des sciences exactes et naturelles* 21 (1887).

Lorentz, Hendrik, "Versuch einer Theorie der elektrischen und optischen Erscheinungen in bewegten Körpern," 1895.

Lovejoy, Arthur, "The Dialectical Argument against Absolute Simultaneity", 1930.

Lynch, Arthur, *The Case Against Einstein*, London: Philip Allan, 1932.

Lynden-Bell, D., J. Katz and J. Bičák, "Mach's Principle from the Relativistic Constraint Equations," *Monthly Notices of the Royal Astronomical Society*, 272, 150, 1995.

Macek, W. M. and D. T. M. Davis, Jr., *Applied Physics Letters* 2 (1963).

Mach, Ernst, *Die Mechanik in Ihrer Entwicklung Historisch-Kritisch Dargestellt*, Leipzig: Brokhaus, 1883. English title: *Mechanics: A Critical and Historical Account of its Development*, translated by T. J. Macormack, La Salle, Open Court Publishing, 1960, 6th edition.

Mach, Ernst, *History and Root of the Principle of the Conservation of Energy*, Note No. 1, published 1872, reprinted by Open Court Publishing Co., La Salle, IL, 1911.

MacRobert, Alan, "Beating the Seeing," *Sky and Telescope*, 89, 4, 1995.

MacRobert, Alan M., *Sky and Telescope*, "Old Galaxies in the Young Universe," January 6, 2004.

MacRoberts, D. T., *Galilean Electrodynamics*, Sept/Oct 1992.

Maddox, Sir John Maddox, "More Precise Solar-limb Light Bending," *Nature* 377:11, 1995.

Magie, William F., "The Primary Concepts of Physics," *Science*, vol. XXXV, February 23, 1912, as cited in Loyd S. Swenson, Jr., *The Ethereal Aether*, Austin and London, University of Texas, 1972.

Magueijo, João, *Faster than the Speed of Light*, Cambridge, Massachusetts, Perseus Publishing, 2003.

Manuel, F., *A Portrait of Isaac Newton*, Cambridge, Massachusetts, 1968.

Marangos, Jon, "Faster Than a Speeding Photon," *Nature*, Vol. 406, July 20, 2000.

Marinov, Stephen, *Eppur Si Muove*, Brussels: CBDS-Pierre Libert, 1977.

Marinov, Stefan, *Foundations of Physics* 8 (1978).

Marinov, S., *General Relativity and Gravity* 12, 57, 1980b.

Markov, M. A., Supplement of the Progress of Theoretical Physics, 1965, as cited in "Spontaneous Breaking of Symmetry and Fundamental Mass" by Umida Ibadova, Dept. of Theoretical Physics, Samarkand, Uzbekistan.

Marmets, Paul, www.newtonphysics.on.ca.

Marmet, Paul, and Christine Couture, "Relativistic Deflections of Light Near the Sun Using Radio Signals and Visible Light," (<http://is.volta.alessandria.it/episteme/marm1.html>).

Marmet, Paul, Grote Reber, "Cosmic matter and the nonexpanding universe," *IEEE Transactions of Plasma Science*, 17, no.2, 264, 1989.

Marrin, West, *Universal Water: The Ancient Wisdom and Scientific Theory of Water*, Hawaii, Interocean Publishing, 2002.

Martin, Geoffrey J. and Preston E. James, *All Possible Worlds: A History of Geographical Ideas*, 4th edition, Oxford University Press, 2005.

Mascart, M., "Sur les modifications qu'éprouve la lumière par suite du mouvement de la source lumineuse et du mouvement de l'observateur," *Annales Scientifiques de l'École Normale Supérieure* Sér.2, 1, 1872.

Matthews, Robert, "Do Galaxies Fly through the Universe in Formation?" *Science*, 271:759, 1996.

Matthews, R., "Inertia: Does Empty Space Put Up the Resistance?" *Science*, Vol. 263, 1994.

Mavrides, Stamatia, "Anomalous Hubble Expansion and Inhomogeneous Cosmological Models," *Monthly Notices of the Royal Astronomical Society*, 177, 1976.

Maxwell, James Clerk, "Ether," *Encyclopedia Britannica*, 9th edition, Edinburgh: Adam and Charles Black, 1875, republished by Cambridge University Press, 1890.

Maxwell, James Clerk, "Atom," *Encyclopedia Britannica*, 9th edition, Edinburgh: Adam and Charles Black, 1875, republished by Cambridge University Press, 1890.

Maxwell, James Clerk, *A Treatise on Electricity and Magnetism*, Oxford University Press, London, 142, 670, 1873.

Maxwell, James Clerk, *Scientific Papers of James Clerk Maxwell*, New York: Dover Publications, 1965.

Mayer, J. R., "Remarks on the Mechanical Equivalent of Heat," translated by J. C. Foster, *The Correlation and Conservation of Forces*, D. Appleton, New York, 1867.

McCauley, J. L., Letters on File, 10-1-04.

McColley, Grant, *The Defense of Galileo of Thomas Campanella*, RPC: Richwood Publishing Co., Merrick, NY, 1937, Reprint 1976.

McCrea, W. H., *Relativity Physics*, fourth edition, London, Methuen, 1954.

McIntyre, J. Lewis McIntyre, *Giordano Bruno*, London, 1903.

McMullin, Eman, editor, *Galileo Man of Science*, Basic Books, Inc., Publishers, NY, London, 1967.

McRobert, Alan M., *Sky and Telescope*, December 2002.

Mehra, J. and H. Rechenberg, *The Historical Development of Quantum Theory*, Vol. 1, Part 1: "The Quantum Theory of Planck, Einstein, Bohr, and Sommerfeld: Its Foundation and the Rise of Its Difficulties" (1900-1925), New York: Springer-Verlag, 1982.

Melanchthon, Philip, *Doctrine of Physics*.

Melberg, Hans, *How Much Gossip is Required Before Science Becomes Interesting*, Walker Publishing, 2000.

Merli, P. G., et al., "On the Statistical Aspect of Electron Interference Phenomena," *American Journal of Physics* 44, 306-307, 1976.

Messenger, Fr. Ernest, *Evolution and Theology: The Problem of Man's Origin*, New York, Macmillan and Company, 1932.

Michell, John, *Philosophical Transactions of the Royal Society of London*, 1783.

Michelson, A. A., "The Effect of the Earth's Rotation on the Velocity of Light," *The Astrophysical Journal*, April 1925, Vol .LXI, No. 3.

Michelson, A. A., F. G. Pease and F. Pearson, "Repetition of the Michelson-Morley experiment," *Journal of the American Optical Society* 18, 1929.

Michelson, A. A., F. G. Pease and F. Pearson, "Repetition of the Michelson-Morley experiment," *Nature* 123, 1929.

Michelson, Albert, "Relative Motion of the Earth and the Ether," *American Journal of Science*, vol. III, June 1897.

Michelson, Albert, *Philosophical Magazine*, London, sixth series, 8, 1904.

Michelson, Albert A., and E. W. Morley, "The Relative Motion of the Earth and the Luminiferous Ether," *American Journal of Science*, Vol. 22, August 1881.

Michelson, Albert and Edward Morley, "Influence of Motion of the Medium on the Velocity of Light," *American Journal of Science*, 31, 1886.

- Michelson, Albert and Edward Morley, "On the Relative Motion of the Earth and the Luminiferous Ether," *American Journal of Science*, Third Series, Vol. xxxiv (203), Nov. 1887.
- Mikkelsen, D. R., M. J. Newman, "Constraints on the Gravitational Constant at Large Distances," *Physical Review*, D 16, 1977.
- Miller, Arthur I., *The Special Theory of Relativity: Emergence and Early Interpretation*, (Springer-Verlag, New York, 1998.
- Miller, Dayton, "The Ether-Drift Experiment and the Determination of the Absolute Motion of the Earth," *Reviews of Modern Physics*, vol. 5 (2), July 1933.
- Miller, Dayton, "The Ether-Drift Experiments at Mount Wilson Solar Observatory," *Physical Review*, 19:407-408, 1922.
- Milne, E. A. *Relativity, Gravitation, and World Structure*, Oxford University Press, 1935.
- Milnes, Harold W., "Faster Than Light?" *Radio-Electronics*, Vol. 54, Jan 1983.
- Milton, K. A., *The Casimir Effect: Physical Manifestations of Zero-point Energy*, World Scientific, Singapore, 2001.
- Milton, Richard, *Forbidden Science: Exposing the Secrets of Suppressed Research*, Cox and Wyman Ltd., Great Britain, 1994.
- Minkel, J. R., "The Power of Five," *New Scientist*, July 3, 2004.
- Minkowski, Hermann, Minkowski's 1908 lecture to the 80th Assembly of German Natural Scientists and Physicians.
- Misner, Charles W., Kip S. Thorne and John A. Wheeler, *Gravitation*, New York, W. H. Freeman and Co., 1973.
- Mitchell, Joni, song lyrics "Woodstock," 1969.
- Mitchell, William C., *Bye, Bye Big Bang: Hello Reality*, Common Sense Books, 2002.
- Mirabel, I. F. and L. F. Rodriguez, "A Superluminal Source in the Galaxy," *Nature* 371 no. 1 (1994).
- Mivart, Fr. George, *On the Genesis of Species*, New York: D. Appleton and Company, 1871.
- Mizwa, A. M., Paul, *Nicholas Copernicus*, The Kosciuszko Foundation, New York, 1943.
- Möllenstedt, G. and H. Düker, *Zeitschrift für Physik* 145, 377-397.
- Møller, C., *The Theory of Relativity*, Oxford, Clarendon Press, 1952.
- Møller, C., *The Theory of Relativity*, second edition, Oxford, Clarendon Press, 1972.
- Montgomery, Alan and Lambert Dolphin, "Is the Velocity of Light Constant in Time?" *Galilean Electrodynamics*, Vol. 4, No. 5, Sept-Oct 1993.

- Moody, Jr., Richard, "Plagiarism Personified," *Mensa Bulletin*, 442, February 5, 2001.
- Moody, Richard, in *Nexus Magazine*, vol. 11, no. 1, Dec.-Jan. 2004.
- Moon, Parry, and Domina E. Spencer, "Binary stars and the velocity of light," *Journal of the Optical Society of America*, Vol. 43, 1953.
- Moon, Parry and Domina Spencer, "Mach's Principle," *Philosophy of Science*, 26, 1959.
- Moon, Parry, and Domina E. Spencer, "On the establishment of universal time," *Philosophy of Science*, Vol. 23, 1956.
- Moon, Parry, Domina E. Spencer and E. E. Moon, "The Michelson-Gale experiment and its effect on the postulates of the velocity of light," *Physics Essays*, Vol. 3, No. 4, 1990.
- Moon, Parry, Domina E. Spencer and E. E. Moon, "Universal time and the velocity of light," *Physics Essays*, Vol. 2, 1989.
- Moon, Parry, Domina E. Spencer and U. Y Shama, "The Sagnac effect and the postulates on the velocity of light," *Physics Essays*, Vol. 4, No. 2, 1991.
- Moon, Robert, "Space Must Be Quantized," *21st Century*, May-June, 1988.
- Mooney, Stephen, "From the Cause of Gravity to the Revolution of Science," *Apeiron*, vol. 6, no. 1-2, 1999.
- Morales-Tecotl, H. and C. Rovelli: "Loop space representation of quantum fermions and gravity," *Nuclear Physics B* 451, 325, 1995.
- Morgan, H. R., *Journal of the Optical Society of America*, 20, 225, April 1930.
- Morrison, L. V., C. G. Ward, "An analysis of the transits of Mercury: 1677-1973," *Notes of the Royal Astronomical Society* 173, 183-206, 1975.
- Morrison, Philip and Phylis, "The Big Bang: Wit or Wisdom?" *Scientific American*, February 2001.
- Mossotti, O. F., "On the Forces which Regulate the Internal Constitution of Bodies," 1830.
- "Most Distant Galaxies Surprisingly Mature," *Science News*, 119:148, 1981.
- Motte, Andrew, translator, *Sir Isaac Newton's Mathematical Principles of Natural Philosophy and His System of the World*, vol. I, Berkeley, CA, University of California Press, 1966.
- Moyer, Michael, "Journey to the 10th Dimension," *Popular Science*, March 2004.
- Mullan, Dermott, astrophysicist at the University of Delaware, private correspondence on file.
- Muller, *Scientific American*, May, 1978.

- Müller, Holger, Sven Herrmann, Claus Braxmaier, Stephan Schiller, and Achim Peters, "Modern Michelson-Morley Experiment using Cryogenic Optical Resonators," *Physical Review Letters* 91, 020401 (2003).
- Múnera, Héctor A., "An Absolute Space Interpretation of the Non-Null Results of Michelson-Morley and Similar Experiments" in *Apeiron*, Vol. 4, Nr. 2-3, Apr-July 1997.
- Múnera, Héctor, "Michelson-Morley Experiments Revisited: Systematic Errors, Consistency Among Difference Experiments, and Compatibility with Absolute Space," *Apeiron*, Vol. 5, Nr. 1-2, January-April 1998.
- Munitz, Milton K., *Theories of the Universe*, Glencoe, IL: Free Press, 1957.
- Murray, W. A. Scott, "If you want to know the time..." *Wireless World*, December, 1986.
- Mushotzky, Richard F. Mushotzky, NASA Goddard Space Flight Center, as cited in *Science News*, Vol. 158, No. 17, Oct. 21, 2000.
- Musser, George, "Was Einstein Right?" *Scientific American*, September 2004.
- Napier, William, and Geoffrey Burbidge, *Monthly Notices of the Royal Astronomical Society*, 342, 2003.
- Narlikar, Jayant, *Times of India*, July 30, 1994.
- Narlikar, J. V., and N. C. Rana, "Newtonian N-body calculations of the advance of Mercury's perihelion," *Notes of the Royal Astronomical Society* 213, 657-663, 1985.
- Needham, Joseph, "Marx's Theory on the Historical Process," *Science at the Crossroads*, London, Frank Cass and Co., 1971.
- Neher, André, *Jewish Thought and the Scientific Revolution of the Sixteenth Century: David Gans (1541-1613) and His Times*, translated from the French by David Maisel, Oxford University Press, 1986.
- Nemo, Patricia, "Whose Relativity Was It, Anyway?" *College of St. Thomas Magazine*, Spring 1990.
- Newcomb, S., "Tables of Mercury," *Astronomical Papers of American Ephemeris Nautical Almanach*, 6, Washington (1895-1898).
- Newton, Isaac, *Mathematical Principles of Natural Philosophy*, Berkeley, 1962.
- Newton, Isaac, Letter to Halley, June 20, 1686 in reference to Newton's paper "An Hypothesis Explaining the Properties of Light," registered in the Royal Society in 1675, *Correspondence*.
- Newton, Isaac, letter to Oldenberg, Dec. 7, 1675.
- Newton, Isaac, *Opticks*, Dover Publications, New York, 1952, from the fourth edition, 1730.
- Newton, Isaac, *Philosophiae Naturalis Principia Mathematica*, translated by Andrew Motte (1729), revised, Florian Cajori, Berkeley: University of California Press, 1934.

Newton, Isaac, *Scholium to the Definitions in Philosophiae Naturalis Principia Mathematica*, Book 1 (1689); translated by Andrew Motte (1729), rev. Florian Cajori, Berkeley: University of California Press, 1934.

Newton, Isaac, *Principia*, Book III, cited in “The Unpublished Scientific Papers of Isaac Newton,” A. R. Hall and M. Boas Hall, editors, Cambridge, MA, 1962.

Newton, Isaac, *Third Letter to Bentley*, February 25, 1693, Newton’s Correspondence, registered in the Royal Society in 1675, *Correspondence*, vol. 3.

Newton, Isaac, “To the Reverend Dr. Richard Bentley, at the Bishop of Worcester’s House, Park Street, Westminster from Cambridge, December 10, 1692,”

Nicholas of Lyra, *Postillae perpetuae*.

Nieto, Michael, “Nailing Down Gravity,” *Discover*, October 2003.

Nietzsche, “The Gay Science,” *Thus Spoke Zarathustra*, 1885.

Nieves, L., M. Rodriguez, G. Spavieri, and E. Tonni, “An experiment of the Trouton-Noble type as a test of the differential form of Faraday’s law,” *Il Nuovo Cimento* 116 B (5), 585–592, 2001.

Nightingale, J. David, “Specific Physical Consequences of Mach’s Principle,” *American Journal of Physics*, 1977, vol. 45.

Nobili Anna Maria, and Clifford M. Will, “The Real Value of Mercury’s Perihelion Advance,” *Nature* 320, 39-41, 1986.

Nodland, Borge and John Ralston, “Indication of Anisotropy in Electromagnetic Propagation over Cosmological Distances,” *Physical Review Letters* 78, 16:3043, April 21, 1997.

Nordenson, Harold, *Relativity, Time and Reality*, London: Allen and Unwin, 1969.

North, J. D., *The Measure of the Universe*, Oxford, Clarendon Press, 1965.

Northrop, Eugene P., *Riddles in Mathematics*, Krieger Publishing, 1975.

Norton, John D., “Einstein’s Investigations of Galilean Covariant Electrodynamics Prior to 1905,” University of Pittsburgh, Dept. of History and Philosophy of Science, Jan. 28, 2004.

Nunn, T. P., *Relativity and Gravitation*, London, University of London Press, 1923.

Obukov, Yu, N., “Rotation in Cosmology,” *General Relativity and Gravitation*, Vol. 24, No. 2, 1992.

Obukhov, Yu, N., “Gauge Theories of Fundamental Interactions,” World Scientific, Singapore, 1990.

Omer, Guy C. Jr., “A Nonhomogeneous Cosmological Model,” *Journal of the American Astronomical Society*, 109, 1949.

- O’Rahilly, Alfred, *Electromagnetics: A Discussion of Fundamentals*, Longmans, 1938; Dover reprint edition, 1965.
- Orwig, Lawrence P., “Machian Effect in Compact, Rapidly Spinning Shells,” *Physical Review D*, 1757-1763, 1978, abstract.
- Otis, Arthur S., *Light Velocity and Relativity*, Yonkers-on-Hudson, New York, Christian E. Burckel and Associates, 1963.
- Overbye, Dennis, “Universe as Doughnut: New Data, New Debate,” *The New York Times*, March 11, 2003.
- Ozernoy, Leonid, *Astronomicheskii Tsirkulyar*, No. 407, 1967.
- Padmore, Tim, “A Great Theory Once – Now It’s Been Recycled,” *Vancouver Sun*, Vancouver, Canada.
- Pais, Abraham, *Subtle is the Lord: The Science and the Life of Albert Einstein*, Clarendon Press, Oxford, 1982.
- Pannekoek, A., *A History of Astronomy*, New York, Interscience Publishers, 1961; originally published in 1951 under the Dutch title: *De Groei van ons Wereld*.
- Pappas, P. T., and Alexis G. Obolensky, “Thirty-Six Nanoseconds Faster Than Light,” *Electronics and Wireless World*, Dec. 1988.
- Pascal, Blaise, *Pensées sur la religion*, 1669.
- Paul, Erich Robert, *The Milky Way Galaxy and Statistical Cosmology: 1890-1924*, Cambridge University Press, 1993.
- Pauli, W., Jr., “Relativitätstheorie,” *Encyclopedia Math. Wiss.* V-2, hft 4, 19, 679, 1920.
- Pauli, Wolfgang, *Theory of Relativity*, translated by G. Field, New York, Dover Publications, 1958.
- Pearson, T. J., *et al*, in “Superluminal Expansion of Quasar 3C273,” *Nature* 290:365, 1997.
- Pederson, Olaf, *A Survey of the Almagest*, Odense, Denmark, Odense University Press, 1974.
- Peebles, James, *Science Frontiers*, No. 105: May-June 1996.
- Peebles, James; David N. Schramm; Edwin L. Turner and Richard G. Kron, “The Evolution of the Universe,” *Scientific American*, October 1994.
- Penrose, Roger, *The Road to Reality: A Complete Guide to the Laws of the Universe*, New York, Alfred Knoph, 2005.
- Penzias, A. A., Wilson, R. W., *Astrophysical Journal*, 142: 419-427 (1965).
- Peratt, A., and D. Nielsen, “Evolution of Colliding Plasmas,” *Physical Review Letters*, 44, 1767-1770, 1980.

- Peters, Christian H.F., *Ptolemy's Catalogue of Stars: A Revision of the Almagest*, Carnegie Institute of Washington, 1915.
- Peterson, I., "A New Gravity? Challenging Einstein's General Theory of Relativity," *Science News*, Vol. 146, 1994.
- Peterson, Ivars, *Newton's Clock: Chaos in the Solar System*, New York: William H. Freeman and Co., 1993.
- Philippi IV, Regnis, *Index Librorum Prohibitorum et Expurgandorum Novissimus, Pro Catholicis Hispaniarum*, Madrid, 1667.
- Piccard, A. and E. Stahel, "L'absence du vent d'ether au Rigi," *Comptes Rendes*, 185, 1927.
- Piccard, A. and E. Stahel, "Sur le vent d'ether," *Comptes Rendes*, 184 (1927).
- Pireaux, S., J. P., and Rozelot, S. Godier, "Solar quadrupole moment and purely relativistic gravitation contributions to Mercury's perihelion Advance," *Astrophysics and Space Science* 284, 2003.
- Planck, Max, "Sitz. der preuss. Akademie der Wissenschaften," *Physik. Math. Klasse*. Berlin, June, 1907.
- Podolsky, Boris and Nathan Rosen, "Can Quantum-Mechanical Description of Physical Reality be Considered Complete?" versus the Copenhagen group headed by Bohr (Erwin Schrödinger, Max Born, Werner Heisenberg, et al), 1935.
- Pogany, B., Über die Wiederholung des Harres – Sagnaschen Versuches. *Ann. Phys.*, 1926, 80.
- Poincaré, Henri, *La science et l'hypothèse*, 1901, now published in Paris, Flammarion, 1968.
- Poincaré, Henri, lecture: "L'état actuel et l'avenir de la physique mathématique," St. Louis, Sept. 24, 1904, *Scientific Monthly*, April, 1956.
- Poincaré, Henri, *New Methods of Celestial Mechanics*, ed. Daniel L. Goroff, New York: American Institute of Physics, 1993.
- Poincaré, Henri, "The Principles of Mathematical Physics," *The Monist*, vol. XV, January 1905.
- Poincaré, Henri, "The Theory of Lorentz and the Principle of Reaction," 1900.
- Polanyi, M., *The Logic of Liberty*, 1951.
- Poor, Charles Lane, "The Deflection of Light as Observed at Total Solar Eclipses," *Journal of the Optical Society of America* 20, 1930.
- Poor, Charles Lane, *Gravitation versus Relativity*, New York: G. P. Putnam's Sons, Knickerbocker Press, 1922.
- Poor, Charles Lane, "Relativity: An Approximation," Paper presented to the American Astronomical Society, Thirteenth Meeting, 1923, Mount Wilson Observatory, California.

- Pope Pius X, encyclical of March 12, 1904, *Iucunda Sane*, 35.
- Popović, Milan, editor, *In Albert's Shadow: The Life and Letters of Mileva Marić*, Baltimore: Johns Hopkins Univ. Press, 2003.
- Popper, Karl, *Conjectures and Refutations: The Growth of Scientific Knowledge*, New York, Routledge, 1992, 2002.
- Porter, Monica, "Relatively imperfect genius," *Jewish Chronicle*, August 8, 1993.
- Posch, Helmut, *Das wahre Weltbild nach Hildegard von Bingen*, Deutsche Bibliothek – CIP – Einheitsaufnahme, Aufl. – A-4880 St. Georgen, 1998.
- Post, E. J., in *Reviews of Modern Physics* 39 (2), 475, 1967.
- Pound and Rebka, "Apparent Weight of Photons," *Physical Review Letters* 4, 337, 1960.
- Prachett, Terry, *Lords and Ladies*, New York, Harper Prism, 1994.
- Preston, S. T., *Physics of the Ether*, E. & F. N. Spon, London, 1875, #165.
- Prokhovnik, S.J., "Light in Einstein's Universe," Dordrecht, Reidel, 1985.
- Ptolemy, *E Mathematike Syntaxis*, A.D. 142, retitled: *The Almagest*.
- Puthoff, H.E., "Gravity as a Zero Point Fluctuation Force," *Physical Review A*, Vol. 39, No. 5, 1989.
- Ragazzoni, Roberto, Massimo Turatto and Wolfgang Gaessler, "The Lack of Observational Evidence for the Quantum Structure of Spacetime at Planck Scales," *The Astrophysical Journal*, April 10, 2003.
- Rauch, Alan, *Useful Knowledge: The Victorians, Morality And The March of Intellect*, Durham: Duke University Press, 2001.
- Rautenberg, V., and N. P. Plag, M. Burns, G. E. Stedman and H. U. Juttner, "Tidally induced Sagnac signal in a ring laser," *Geophysical Research Letters* 24 (8): 893-896, 1997.
- Rayleigh, Lord, "On the Theory of Optical Images," *Philosophical Magazine*, 42:167 (1896).
- Rayleigh, Lord, *Philosophical Magazine*, 4, 678 (1902) and (1904).
- Reber, Grote, "Big bang creationism," *Physics Today*, 35, Nov. 1982.
- Reber, Grote, "Cosmic radio-frequency radiation near one megacycle," G. Reber and G. R. Ellis, *Journal of Geophysical Research*, 61, 1, 1956.
- Reber, Grote, "Cosmic Radio Noise," *Radio-Electronic Engineering*, July 1948.
- Reber, Grote, "Cosmic Static," *Astrophysical Journal*, 91, 1940.
- Reber, Grote, "Cosmic Static," *Astrophysical Journal*, 100, 279, 1944.

- Reber, Grote, "Cosmic Static at 144 meters wavelength," *Journal of the Franklin Institute*, vol. 285, Jan. 1968.
- Reber, Grote, "Cosmic Static," *Proc. IRE*, 28, 68, 1940.
- Reber, Grote, "Cosmic Static," *Proc. IRE*, 30, 367, 1942.
- Reber, Grote, "Cosmic Static," *Proc. IRE*, 36, 1215, 1948.
- Redmount, Ian and Wai-Mo Suen, "De Broglie Waves on Dirac Aether," *Lettere Al Nuovo Cimento*, vol. 29, No. 14, Dec. 1980.
- Redmount, Ian and Wai-Mo Suen, "Is Quantum Spacetime Foam Unstable?" Rapid Communication, *Physical Review D*, 47, 2163, 1993.
- Reeves, H., "The Non-expanding universe," *Journal of the Royal Astronomical Society*, 83, 223, 1989.
- Regener, Erhard, *Zeitschrift fur Physik*, 106:633-661, 1933.
- Reich, Robert, "The Last Word," *The American Prospect*, July 1, 2004.
- Reichenbach, Hans, *From Copernicus to Einstein*, translated by Ralph B. Winn, New York, Dover Publications, 1970.
- Reid, Constance, *Hilbert*, New York, Springer-Verlag, 1907.
- Renn, Jürgen, editor, *Galileo in Context*, Cambridge, Cambridge University Press, 2001.
- Renn, Jürgen, and Robert Schulmann, *Albert Einstein: Mileva Marić: The Love Letters*, translated by Shawn Smith, Princeton University Press, 1992.
- Rescher, Nicholas, *Scientific Progress*, Oxford, United Kingdom, Basil Blackwell, 1978.
- Resnick, Robert and David Halliday, *Basic Concepts in Relativity and Early Quantum Theory*, New York, John Wiley and Sons, 1985.
- Reston, Jr., James, *Galileo a Life*, Harper Collins Publishers, 1994.
- Rheticus, *Narratio prima*, dated 1540, translated by Edward Rosen, in *Three Copernican Treatises*, New York, Octagon Books, 1971.
- Riehle, F. et al, *Physical Review Letters*, 67, 177 (1991).
- Rindler, W., *Introduction to Special Relativity*, second edition, Clarendon, Oxford University Press, 1991.
- Ritz, W., *Annales de Chimie et de Physique*, vol. 13, 145, 1908.
- Ritz, W. and A. Einstein, *Physique Zeitschrift* 10, 323, 1909.
- Rizzi, G., "The Sagnac Phase shift suggested by the Aharonov-Bohm effect for relativistic matter beams," Guido Rizzi, *et al*, May, 2003.

- Rizzi, G. and M. Ruggiero, *Relativity in Rotating Frames*, Kluwer Academic Publishers, Dordrecht, 203.
- Rizzi, G. and A. Tartaglia, "Speed of Light on Rotating Platforms," *Foundational Physics*, 28:1663, 1998.
- Robinson, A., "The Metaphysics of the Calculus" in *The Philosophy of Mathematics*, editor, Jaakko Hintikka, Oxford University Press, 1969.
- Robinson, Leif M., "The Disquieting Sun: How Big, How Steady?" *Sky and Telescope*, 63:354, 1982.
- Roentgen (or Röntgen), W. C., *Annalen der Physik* 35:264 (1888).
- Rogers, Donald, W. *Einstein's Other Theory: The Planck-Bose-Einstein Theory of Heat Capacity*, Princeton University Press, 2005.
- Roseveare, N. T., *Mercury's Perihelion from Le Verrier to Einstein*, Oxford University Press, 1983.
- Ross, Hugh, *Beyond the Cosmos: What Recent Discoveries in Astronomy and Physics Reveal about the Nature of God*, Colorado: NavPress, 1996.
- Ross, Hugh, *Creation and Time: A Biblical and Scientific Perspective on the Creation-Date Controversy*, Colorado: NavPress, 1994.
- Ross, Hugh, *The Creator and the Cosmos: How the Greatest Scientific Discoveries of the Century Reveal God*, Colorado: NavPress, 1993.
- Ross, Hugh, *The Fingerprint of God*, CA: Promise Publishing Co., 1989, 1991.
- Ross, Hugh, *The Genesis Question: Scientific Advances and the Accuracy of Genesis*, Colorado: NavPress, 1998.
- Ross, John, *Chemical and Engineering News*, July 27, 1980.
- Rosser, William, G. V., *An Introduction to the Theory of Relativity*, London, Butterworths, 1964.
- Rosser, William, G. V., *Introductory Relativity*, London, Butterworths, 1967.
- Roth, Joshua, "Gamma-Ray Bursts Next Door," *Sky and Telescope*, January 9, 2002.
- Rothwarf, Allen, "Cosmological Implications of the Electron-Positron Aether," *Physics Essays*, 11, 1998.
- Rothwarf, Frederick R and Sisir Roy "The Time Dependence of Fundamental Constants and Planck Scale Physics," November 14, 2003.
- Rovelli C., "Loop space representation In: New perspectives in canonical gravity," A. Ashtekar Bibliopolis, Naples 1988.
- Rovelli, C. and L. Smolin: "Knot theory and quantum gravity," *Physical Review Letters* 61, 1155, 1988.

- Rovelli, C., L. Smolin: "Loop space representation for quantum general relativity," *Nuclear Physics B* 331, 80, 1990.
- Rovelli, C. and L. Smolin: "Spin Networks and Quantum Gravity," *Physical Review D* 53, 5743, 1995.
- Rowan-Robinson, Michael, "Aether drift detected at last," *Nature*, Vol. 270, November 3, 1977.
- Rowan-Robinson, Michael, "Extragalactic Distance Scale," *Nature*, Dec. 16, 1976, vol. 264.
- Rowe, C. H., and K. U. Schreiber, S. J. Cooper, B. T. King, M. Poulton and G. E. Stedman "Design and operation of a very large ring laser gyroscope," *Applied Optics* 38 (12): 2516-2523, 1999.
- Rowlan, Wade, *Galileo's Mistake: A New Look at the Epic Confrontation between Galileo and the Church*, Arcade Publishers, New York, 2001.
- Roxburgh, Ian W., "Solar Rotation and the Perihelion Advance of the Planets," *Icarus*, 3:92, 1964.
- Rubin, Vera C., Norbert Thonnard and W. Kent Ford, Jr., "Motion of the Galaxy and the Local Group determined from the velocity anisotropy of distant Sc I galaxies," *The Astronomical Journal*, vol. 81, No. 9, Sept. 1976.
- Rucker, Rudy, *Infinity and the Mind*, Boston, Birkhauser, 1982.
- Rudin, W., *Mathematical Analysis*, New York, McGraw-Hill, 1964.
- Rueda, A., B. Haisch and D. C. Cole, "Vacuum Zero-Point Field Pressure Instability in Astrophysical Plasmas and the Formation of Cosmic Voids," *Astrophysical Journal*, 445, 7, 1995.
- Rugh, S. E. and Henrik Zinkernagel, "The Quantum Vacuum And The Cosmological Constant Problem," *Studies in History and Philosophy of Modern Physics* 33, 2001.
- Russell, Bertrand, *Mysticism and Logic*, Doubleday, 1957.
- Russell, Bertrand, *The ABC of Relativity*, London, revised edition, editor Felix Pirani, New York, Signet Books, New American Library; England, George Allen and Unwin, 1958.
- Russell, Jeffrey, *Inventing the Flat Earth*, Praeger Paperback, 1997.
- Rutherford, James F., Gerald Holton and Fletcher G. Watson, *The Project Physics Course*, New York, Holt, Rinehart and Winston, Inc., 1970.
- Safarti, Jonathan, "The Sun: Our Special Star: Sunspots, Galileo and Heliocentrism," *Answers in Genesis*, Vol. 22, Issue 1, p. 5.
- Sagan, Carl, "A Gift for Vividness," *Time*, October 20, 1980, p. 61.
- Sagan, Carl, *Broca's Brain*, New York: Random House, 1979.
- Sagan, Carl, *Contact*, New York: Pocket Books, 1985.

- Sagan, Carl, *Cosmos*, New York: Random House, 1980.
- Sagan, Carl, *Dragons of Eden*, New York: Random House, 1977.
- Sagan, Carl, *Pale Blue Dot: A Vision of the Human Future in Space*, New York, Ballantine Books, 1977.
- Sagan, Carl, *The Demon-Haunted World: Science As a Candle in the Dark*, Random House, 1996.
- Sagnac, Georges, and E. Bouty, "The Luminiferous Ether Demonstrated by the Effect of the Relative Motion of the Ether in an Interferometer in Uniform Rotation" (in French): E. Bouty, *Comptes Rendus de l' Académie des Sciences* (Paris) 157, 1913.
- Sagnac, Georges, *Journal de Physique et le Radium*, fifth series, 4, 1914.
- Sánchez, J. –F., et al, "Geometry of an Accelerated Rotating Disk," Universidad de Valladolid, Spain, 2003.
- Sandage, Allan, "Cosmology," *Hammond Barnhart Dictionary of Science*, Barnhart Books, 1986.
- Sandage, Allan, *Journal of the Royal Astronomical Society of Canada*, Vol. 83, No. 6, Dec. 1989.
- Sard, R. D., *Relativistic Mechanics*, W. A. Benjamin, Inc., New York, 1970.
- Saxl, Erwin, "An Electrically Charged Torque Pendulum," *Nature*, v. 203, 1964.
- Schaeffer, Francis, *The God Who is There*, Crossway Books, 1990.
- Schechter, Paul L., "On the Solar Motion with Respect to External Galaxies," *Astronomical Journal*, vol. 82, August 1977.
- Schilling, Govert, "New results reawaken quasar distance dispute," *Science*, October 11, 2002.
- Schilpp, Edward, *Albert Einstein, Philosopher Scientist*, Library of Living Philosophers, 1949.
- Schilpp, Paul, A., editor, *Albert Einstein: Philosopher-Scientist*, New York, MJF Books, 1949, 1951, 1969, 1970, with Open Court Publishing, 1988.
- Schleich, W and M. O. Skully, "Course 10: General Relativity and Modern Optics," *New Trends in Atomic Physics*, Elsevier Science Publishers, Amsterdam-New York, 1982.
- Schlick, Moritz, *Ernst Mach, der Philosoph*, in a special supplement on Ernst Mach in the *Neue Freie Presse* (Vienna), June 12, 1926.
- Schoepffer, C., *The Earth Stands Fast*, C. H. Ludwig, 1900.
- Schreiber, U., M. Schneider, C. H. Rowe, G. E. Stedman, S. J. Cooper, W. Schlüter and H. Seeger, "The C-II ring laser project," *Phys. Chem. Earth A* 25 (12): 805-807, 2000.

- Schroeder, G. L., "The Universe – 6 Days and 13 Billion Years Old," *Jerusalem Post*, September 7, 1991.
- Schücking, E. L., "Cosmology," *Relativity Theory and Astrophysics*, editor, Jurgen Ehlers, Providence, RI: American Mathematical Society, 1967.
- Schulmann, Robert, A. J. Kox, Michael Janssen and József Illy, editors, *The Collected Papers of Albert Einstein, Correspondence 1914-1918*, Princeton University Press, 1998.
- Schultze, F. K., synopsis and translation of F. E. Pacshe's *Christliche Weltanschauung*.
- Schwarz, Domionik J., Glenn D. Starkman, Dragan Huterer and Craig J. Copi, "Is the Low- ℓ Microwave Background Cosmic?" *Physical Review Letters*, November 26, 2004.
- Schwarzschild, B., "From Mine Shafts to Cliffs: The 'Fifth Force' Remains Elusive," *Physics Today*, July, 21, 1988.
- Sciama, D. W., "On the Origin of Inertia," *Monthly Notices of the Royal Astronomical Society*, 113:34-42, 1953.
- Sciama, D. W., *The Unity of the Universe*, New York, Doubleday and Company, Anchor Books, 1961.
- Sciama, D. W. and M. J. Rees, "Larger Scale Density Inhomogeneities in the Universe," *Nature*, vol. 217, 1968.
- Sciama, D. W. and M. J. Rees, "Possible Large-Scale Clustering of Galaxies," *Nature*, vol. 213, 1967.
- Sciama, D. W. and M. J. Rees, "Possible Circular Polarization of Compact Quasars," *Nature*, vol. 216, 1967.
- Seidlmayer, Michael, *Currents of Mediaeval Thought: With Special Reference to Germany*, translated by D. Barker, Oxford, Basil Blackwell, 1960.
- Seife, Charles, "Physics in the Twilight Zone," *Science*, 305:464, 2004.
- Selbrede, Martin, G., "Geocentricity's Critics Refuse to Do Their Homework," *The Chalcedon Report*, 1994.
- Selleri, F., *Foundations of Physics*, 26, 641, 1996.
- Selleri, F., "Space-time Transformations in Ether Theories," *Z. Naturforsch.*, 46a, 1990.
- Seneca, *Nat. Quaest.*vii. 2, 3. Cited in *Aristarchus of Samos: The Ancient Copernicus*, Sir Thomas Heath, Oxford, Clarendon Press, 1913.
- Setterfield, Barry, *The Atomic Constants, Light and Time*, self-published, 1987.
- Shakespeare, William, *King John*.
- Shakespeare, William, *Merry Wives*.
- Shakespeare, William, *Troilus and Cressida*.

- Shamir, J. and R. Fox, "A new experimental test of special relativity," *Il Nuovo Cimento* 62B, No. 2, 1969.
- Shankland, Robert, S., "Conversations with Albert Einstein," *American Journal of Physics*, 31:47-57, 1963.
- Shankland, Robert, S. "Conversations with Albert Einstein II," *American Journal of Physics*, 41:895-901, July 1973.
- Shankland, R. S., et al, *Review of Modern Physics* 27:2, 167-178, 1955.
- Shankland, Robert, S., and S. W. McCuskey, F. C. Leone and G. Kuerit, "Analysis of the Interferometer Observations of Dayton C. Miller," *Reviews of Modern Physics*, 27(2):167-178, April, 1955.
- Shapere, Dudley, *Galileo a Philosophical Study*, University of Chicago Press, 1974.
- Shara, Michael, *Discover*, September 2004.
- Sharov, Alexander S. and Igor D. Novikov, translated by Vitaly Kisin, *Edwin Hubble: The Discoverer of the Big Bang Universe*, Cambridge University Press, 1993.
- Sharratt, Michael, *Galileo Decisive Innovator*, Cambridge University Press, 1994.
- Shea, W. R and M. Artigas, *Galileo in Rome: The Rise and Fall of a Troublesome Genius*, Oxford University Press, 2003.
- Sherrard, Philip, *The Rape of Man and Nature: An Enquiry into the Origins and Consequences of Modern Science*, Suffolk, Golgonooza Press, 1987.
- Siepmann, J. P., "The Laws of Space and Observation," *Journal of Theoretics*, Vol. 1, No. 1, 1999.
- Silberstein, Ludwik, *Journal of the Optical Society of America* 5: 291-307, 1921.
- Silk, Joseph, *The Big Bang: The Creation and Evolution of the Universe*, San Francisco, W. H. Freeman and Company, 1980.
- Silvertooth, E. W., *Journal of the Optical Society of America*, 62:1330, 1982.
- Silvertooth, E. W., "Experimental detection of the ether," *Speculations in Science and Technology*, vol. 10, no. 1, May 1986.
- Silvertooth, E. W., and S. F. Jacobs: "Standing Wave Sensor," *Applied Optics* 22 no. 9 (1983).
- Silvertooth, E. W., and C. K. Whitney, "A New Michelson-Morley Experiment," *Physics Essays* 5 no. 1 (1992).
- Simhony, Menahem., *An Invitation to the Natural Physics of Matter, Space, Radiation*, Singapore, New Jersey: World Scientific, 1994.
- Sis, Peter, *Starry Messenger: A Book Depicting the Life of a Famous Scientist, Mathematician, Astronomer, Philosopher, Physicist: Galileo Galilei*, Frances Foster Books at Farrar-Straus-Giroux, New York, 1996.

Slabinski, Victor J., "Notes on gravitation in the Meta Model," *Meta Research Bulletin* 7, 33-42; and "Force, Heat and Drag in the Graviton Model," in *Pushing Gravity*, ed. Matthew R. Edwards, Montreal: C. Roy Key Inc, 2002.

Slusher, Harold S., *The Origin of the Universe: An Examination of the Big Bang and Steady State Cosmologies*, El Cajon, CA, Institute for Creation Research, 1980.

Smith, Wolfgang, *The Wisdom of Ancient Cosmology: Contemporary Science in Light of Tradition*, Oakton, VA: Foundation for Traditional Studies, 2003.

Smolin, Lee, "Atoms of Space and Time," *Scientific American*, Sept. 2004.

Smolin, Lee, *Discover Magazine*, September 2004.

Smolin, Lee, *Three Roads to Quantum Gravity*, New York: Basic Books, 2001.

Smoot, G. F. et al. 1977. *Physical Review Letters* 39: 898. 1979.

Smoot, George, and Keay Davidson, *Wrinkles in Time*, Avon Books, New York, 1993.

Soddy, Frederick, "The Wilder Aspects of Atomic Distintegration," *New World Publications*, St. Stephens House, Westminster S. W. I, 1954.

Sofia, S., et al, "Solar Radius Change between 1925 and 1979," *Nature* 304:522, 1983.

Soldner, J., *Annalen der Physik*, 65:593, 1921.

Soldner, J., *Berliner Astronomisches Jahrbuch*, 1804.

Speake, C. C. et. al., "Test of the Inverse-Square Law of Gravitation Using the 300 m Tower at Erie, Colorado," *Physical Review Letters* 65 (1990b) 1967-1971.

Spencer, Domina and Uma Shama, "A New Interpretation of the Hefele-Keating Experiment," nd.

Spencer, D., and U. Y. Shama, "Stellar Aberation and Postulates on the Velocity of Light," *Physics Essays*, 1996.

Spergel, David, *New Scientist*, October 8, 2003.

Stacey, F. D., and G. J. Tuck, "Geophysical Evidence for Non-Newtonian Gravity," *Nature* 292, 1981.

Standen, Anthony, *Science is a Sacred Cow*, London, Sheed and Ward, 1952; E. P. Dutton Publishers, 2000.

Starkman, Glen D. and Dominik J. Schwarz, "Is the Universe Out of Tune," *Scientific American*, August 2005, p.52.

Stedman, G. E., *Rep. Prog. Phys.*, 60, 615, 1997.

Stedman, G. E., "Ring laser tests of fundamental physics and geophysics," *Rep. Prog. Phys.* 60: 615-688, 1997.

- Stedman, G. E. and K. U. Schreiber and H. R. Bilger, "On the detectability of the Lense-Thirring field from rotating laboratory masses using ring laser gyroscope interferometers," *Classical Quantum Gravity* 20 (13): 2527-2540, (2003).
- Stedman, G. E. and B. G. Wybourne, "Beyond the sixth place of decimals: From Michelson to large ring lasers," *Bulletin de la Société des Sciences et des Lettres de Łódz* 53 (Série: Recherches su les déformations vol 39): 47-56 (2003).
- Stenger, Victor J., *Has Science Found God? The Latest Results in the Search for Purpose in the Universe*, Amherst, NY: Prometheus Books, 2003.
- Stenger, Victor, "Was the Universe Created," *Free Inquiry* 7, 3, Summer 1987 and *Free Inquiry* 23, September 2003.
- Stenner, Michael D., Daniel J. Gauthier and Mark A. Neifeld, "The speed of information in a 'fast-light' optical medium," *Nature* 425, 695-698, 2003.
- Stent, Gunther, *The Paradoxes of Progress*, San Francisco: W. H. Freeman, 1978.
- Stephenson, C. B., *Astrophysics and Space Science*, 51, 117, 1977.
- Stephenson, G., and C. W. Kilmister, *Special Relativity for Physicists* (1958), Dover Publications, 1987.
- Stimson, Dorothy, *The Gradual Acceptance of the Copernican Theory of the Universe*, New York, The Baker and Taylor Company, 1917.
- Stokes, G. G., "On the Aberration of Light," *Philosophical Magazine* 27, 1845.
- Stokes, G. G., "On Fresnel's Theory of the Aberration of Light," *Philosophical Magazine* 28, 1846.
- Stokes, G. G., "On the Constitution of the Luminiferous Aether Viewed with Reference to the Phenomenon of the Aberration of Light," *Philosophical Magazine* 29, 1846.
- Stubbs, C. W. et. al, "Limits on Composition-Dependent Interactions Using a Laboratory Source: Is There a 'fifth force' Coupled to Isospin?" *Physical Review Letters* 62, 1989b.
- Suen, W.-M., "Minkowski Spacetime is Unstable in Semi-Classical Gravity," *Physical Review Letters*, 62, 2217, 1989.
- Susskind, Leonard, *The Cosmic Landscape: String Theory and the Illusion of Intelligent Design*, Little, Brown and Co., 2005.
- Svitil Kathy, *Discover*, May 2003.
- Swenson, L. S., "Michelson and Measurement," *Physics Today* 40, 24, 1987.
- Swenson, Loyd, *The Ethereal Aether*, Austin, University of Texas Press, 1972.
- Szames, Alexandre D., and Patrick Cornille, Jean-Louis Naudin and Christian Bizouard, AIP Conference Proceedings Vol. 504 (1), January 19, 2000.
- Taylor, E. F., and John Wheeler, *Spacetime Physics: Introduction to Special Relativity*, second edition, New York, W. H. Freeman, 1992.

Taylor, Geoffrey I., "Interference with Feeble Light," *Proceedings of the Cambridge Philosophical Society*, 15, 114-115, 1909.

Tegmark, Max, (<http://www.hep.upenn.edu/max/wmap3.html>).

Tegmark, Max, Angélica de Oliveira-Costa and Andrew J. S. Hamilton, "A high resolution foreground cleaned CMB map from WMAP," *Physical Review D*, July 26, 2003.

Tegmark, Max, and G. Efstathiou, *Monthly Notices of the Royal Astronomical Society*, 281, 1297, 1996.

Teller, E., *Physical Review*, 73, 801, 1948.

Teukolsky, Saul A., "The explanation of the Trouton-Noble experiment revisited," *American Journal of Physics* 64 (9), 1104, 1996.

Thayer, William Roscoe, *Throne Makers*, New York, 1899.

Thirring, Hans. Über die Wirkung rotierender ferner Massen in der Einsteinschen Gravitationstheorie. *Physikalische Zeitschrift* 19, 33 (1918), translated: "On the effect of Rotating Distant Masses in Einstein's Theory of Gravitation."

Thirring, Hans. Berichtigung zu meiner Arbeit: "Über die Wirkung rotierender ferner Massen in der Einsteinschen Gravitationstheorie." *Physikalische Zeitschrift* 22, 29, 1921, translated: "Correction to my paper 'On the effect of Rotating Distant Masses in Einstein's Theory of Gravitation.'"

Thomas, Calvin, in *The New Yorker*, November 28, 1964, as cited in Francis Schaeffer's *The God Who is There*, Crossway Books, 1990.

Thomas, Lewis, "On Science and Certainty," *Discover Magazine*, 1980.

Thomas, Lewis, "Making Science Work," *Discover*, March 1981.

Tifft, W. G. and W. J. Cocke, "Evidence for Quantized and Variable Redshifts in the CBR Rest Frame," *Astrophysics and Space Science*, 1997.

Tifft, W. G. and W. J. Cocke, "Galaxy Redshifts Come in Clumps," *New Scientist* of June 22, 1985.

Tifft, W. G. and W. J. Cocke, "Global redshift quantization," *Astrophysical Journal* 287:492-502, 1984.

Tifft, W. G. and W. J. Cocke, "Global Redshift Periodicities: Association with the Cosmic Background Radiation," *Astrophysics and Space Science*, 239, 35, 1996.

Tifft, W. G. and W. J. Cocke, "Quantized Galaxy Redshifts," *Sky and Telescope*, 73:19, 1987.

Tolansky, S., *An Introduction to Interferometry*, New York, John Wiley and sons, 1973.

Tolman, Richard C., *Relativity, Thermodynamics and Cosmology*, Oxford: Clarendon Press, 1934; Mineola, New York, Dover Publications, 1987.

- Tolman, Richard, "The Effect of Inhomogeneity on Cosmological Models," 1934 Proceedings of the National Academy of Sciences, 20 169, 1934, reprinted in 1997 General Relativity and Gravitation, 29 935;
- Tomashek, R., *Annalen der Physik*, 73, 105 (1924); 78, 743 (1925); 80, 509 91926); 84, 161 (1927).
- Tommer, G. J., *Ptolemy's Almagest*, London, Gerald Duckworth and Co., 1984.
- Tonnelat, M. A., *Les principes de la théorie électromagnétique et de la relativité*, Masson, Paris, 1959.
- Tonomura, Akira, et al, "Demonstration of Single-Electron Build-up of an Interference Pattern," *American Journal of Physics* 57, 117-120, 1989.
- Toomer, G. J., "Ptolemy," *Dictionary of Scientific Biography*, New York, Charles Scribner and Sons, 1975.
- Torr, D. G., and P. Kolen, B. N. Taylor and W. D. Phillips, editors, "Precision Measurement and Fundamental Constants II", National Bureau of Standards (U.S.), Spec. Publ. 617, 675-679 (1984).
- Trefil, James S., *Space Time Infinity*, New York, Pantheon Books, 1985.
- Trefil, James S., "The Accidental Universe," *Science Digest*, June 1984.
- Trefil, James S., *The Moment of Creation: Big Bang Physics from Before the First Millisecond to the Present Universe*, New York: Scribner's Sons, 1983.
- Troitskii, V. S., "Physical Constants and the Evolution of the Universe," *Astrophysics and Space Science*, Vol. 139, No. 2, Dec 1987.
- Trouton, F. T. and A. D. Rankine, "On the Electrical Resistance of Moving Matter," *Proceedings of the Royal Society* 80, 420, 1908.
- Trouton, F. T. and H. R. Noble, "The forces acting on a charged condenser moving through space," *Proceedings of the Royal Society*, Vol. 72, 1903; *Phil. Trans. Royal Soc. A* 202, 165-18, 1903.
- Trusted, Jennifer, *Physics and Metaphysics: Theories of Space and Time*, London and New York, Routledge, 1994.
- Tryon, Edward P., "Is the Universe a Vacuum Fluctuation?" *Modern Cosmology and Philosophy*, editor John Leslie, New York, Prometheus, 1998.
- Tryon, Edward P., "Is the Universe a Vacuum Fluctuation?" *Nature*, 246: 396-397, December 1973.
- Tryon, Edward P., "What Made the World?" *New Scientist*, 101: 14-16, March 1984.
- Turner, K. C., and H. A. Hill, "New Experimental Limit on Velocity-Dependent Interactions of Clocks and Distant Matter," *Physical Review*, 1964, vol. 134, No. 1B, Apr. 13, pp B252-B256.

- Twain, Mark, *The Wit and Wisdom of Mark Twain: A Book of Quotations*, New York, Dover Publications, 1999.
- Twain, Mark, *Life on the Mississippi*, 1883.
- Ulam, Stanislaw, M., *Adventures of a Mathematician*, University of California Press, 1976, 1991.
- Vali, V. and R. W. Shorthill, *Applied Optics*, 15, 1099, 1976.
- Van der Kamp, *Bulletin of the Tychoonian Society*.
- Van der Kamp, Walter, *De Labore Solis: Airy's Failure Reconsidered*, British Columbia, Canada, 1988.
- Van der Walls, J.D., *Ober den wereldaether*, Haarlem, Erven Bohn, 1929.
- Van Flandern, Tom, "The Big Bang Brouhaha," *Nature*, 356:731, 1992.
- Van Flandern, Tom, *Dark Matter, Missing Planets and New Comets*, revised edition, Berkeley, CA: North Atlantic Books, 1993.
- Van Flandern, T. "Gravity" in *Pushing Gravity*, editor, Matthew R. Edwards, Montreal: C. Roy Keys Inc, 2002.
- Van Flandern, T., *Physical Letters A* 250 (1998) 1-11.
- Van Flandern, T., "Possible new properties of gravity," Parts I & H, *Meta Research Bulletin* 5, 23-29 & 38-50, 1996.
- Van Flandern, T., "Relativity with Flat Spacetime," *Meta Research Bulletin* 3, 9-13, 1994.
- Van Flandern, T., "The Speed of Gravity: What the Experts Say," *Meta Research Bulletin*, Oct. 18, 2002.
- Van Lunteren, Frans, "Fatio and the Cause for Universal Gravitation," in *Pushing Gravity*, ed. Matthew R. Edwards, Montreal: C. Roy Keys Inc, 2002.
- Varshni, Y. P., *Astrophysics and Space Science*, 37, L1, 1975.
- Varshni, Y. P., *Astrophysics and Space Science*, 43, 3 1976.
- Varshni, Y. P., *Astrophysics and Space Science*, 51, 121, 1977.
- Varshni, Y. P., "Chance Coincidences and the So-Called Redshift Systems in the Absorption Spectrum of PKS 0237-23," *Astrophysics and Space Science*, 74, 3, 1981.
- Varshni, Y. P., "The Red Shift Hypothesis for Quasars: Is the Earth the Center of the Universe?" *Astrophysics and Space Science*, 43: (1), 1976.
- Veltmann, Wilhelm, "Über die Fortplanzung des Lichtes in bewegten Medien," *Annalen der Physik* 150, 1873.
- Veselov, K. E., "Chance Coincidences or Natural Phenomena," *Pushing Gravity*, Matthew R. Edwards, editor, Montreal: C. Roy Keys Inc, 2002.

Vessot, *et al*, *Physical Review Letters* 45, 2081, 1980.

Vigier, J. P., “Causal Superluminal Interpretation of the Einstein-Podolsky-Rosen Paradox,” and “New non-zero photon mass interpretation of Sagnac effect as direct experimental justification of the Langevin paradox,” *Physics Letters A*, 234, 1997.

Vigier, J. P., *Physical Review Letters*, vol. 49, No. 2, July 12, 1982.

Vigier, J. P., *Physical Letters A*, 234, 75, 1997.

Voelkel, James R., *Johannes Kepler and the New Astronomy*, Oxford University Press, New York, Oxford, 1999.

Voigt, Woldemar, “Über das Dopplersche Prinzip, Nachr. Ge. Wiss. Göttingen,” 1887.

Von Humboldt, Alexander, *Kosmos*, 1859, vol. 5.

Von Klüber, H., “The Determination of Einstein’s Light-Deflection in the Gravitational Field of the Sun,” *Vistas in Astronomy*, Pergamon Press, London, 3:41-77, 1960.

Waldrop, Mitchell M., “The Currents of Space,” *Science*, vol. 232, April 4, 1986.

Walker, W. D., “Superluminal propagation speed of longitudinally oscillating electrical fields,” abstract in *Causality and Locality in Modern Physics and Astronomy: Open Questions and Possible Solutions*, S. Jeffers, ed., York University, North York, Ontario, #72, 1997.

Wallace, William A., *Galileo and His Sources: The Heritage of the Collegio Romano in Galileo’s Science*, Princeton University Press, 1984.

Wallis, Charles Glen, translator, *On the Revolutions of Heavenly Spheres*, New York: Prometheus Books, 1995.

Wang, L. J., A. Kuzmich and A. Dogariu, “Gain-assisted Superluminal Light Propagation,” *Nature*, Volume 406, July 20, 2000.

Warburton, Richard and John Goodkind, “The Search for Evidence of a Preferred Reference Frame,” *Astrophysical Journal*, vol. 206, Sept. 1976.

Weber, Wilhelm, “Elektrodynamische Maasbestimmungen, insbesondere über den Zusammenhang des elektrischen Grundgesetzes mit dem Gravitationsgesetze,” Werke, Berlin: Julius Springer, 1894, cited in 21st Century Science by Laurence Hecht, Spring 2001.

Weber, Wilhelm, “Elektrodynamische Maasbestimmungen: Über ein allgemeines Grundgesetz der elektrischen Wirkung,” Werke, Berlin: Julius Springer, 1893.

Weeks, Jeffrey, *Nature*, vol. 425.

Weinberg Steven, *Gravitation and Cosmology*, New York: John Wiley, 1972.

Weinberg, Steven, *Gravitation and Cosmology: Principles and Applications of the General Theory of Relativity*. New York: John Wiley, 1972.

Weinberg, Steven, "The Cosmological Constant Problem," *Reviews of Modern Physics* 61 (1989).

Weinberg, Steven, *The First Three Minutes: A Modern View of the Origin of the Universe*, Basic Books, 1977.

Weisskopf, V. J., *American Scientist*, 71, 5, 473, 1983.

Werner, S. A., et al, *Physical Review Letters*, 42, 1103, 1979.

Wesley, J. P., *Galilean Electrodynamics*, "In Memorium: Stefan Marinov," Spring 1999.

Westfall, Richard S., *Never at Rest: A Biography of Isaac Newton*, Cambridge University Press, 1981, 1983.

Westfall, Richard S., "Newton and the Fudge Factor," *Science*, 179, 751-758, 1973.

Weyland, Paul, "Einsteins Relativitätstheorie – eine wissenschaftliche Massensuggestion," *Tägliche Rundschau*, August 6, 1920.

Weymann, R., T. Boronson and J. Scargle, *Astrophysics and Space Science*, 53, 265, 1978.

Wheeler, John A., "Bohr, Einstein, and the Strange Lesson of the Quantum," *Mind and Nature*, editor, Richard Q. Elvee, New York: Harper and Row, 1981.

Wheeler, John A., "Those Baffling Black Holes," *Time*, Sept. 4, 1978.

Wheeler John, A., and C. M. Patton, "Is Physics Legislated by Cosmology," in *The Encyclopedia of Ignorance*, eds., Ronald Duncan and Mirand Weston-Smith, New York, Pergamon Press, 1977.

Wheeler, John A. and C. M. Patton, "Is Physics Legislated by Cosmology?" *The Encyclopedia of Ignorance*, editors: Ronald Duncan and Miranda Weston-Smith, *Pocket Books*, 1978.

Whitaker, Edmund T., *A History of the Theories of Aether and Electricity*, vol. 1-2, New York, Harper and Brothers, 1953.

Whittaker, Edmund, *A History of the Theories of Aether and Electricity: The Classical Theories*, first edition 1910; revised 1951, Nelson and Sons, Ltd., London.

White, Andrew, *A History of the Warfare of Science with Theology In Christendom*, two volumes, New York, Appleton, 1907.

White, Michael *Isaac Newton: The Last Sorcerer*, Perseus Books, Reading Massachusetts, 1997, originally published in Great Britain by Fourth Estate Limited.

Whitehead, Alfred North, *The Concept of Nature*, University Press, 1955.

Whitrow, G. J., *The Structure and Evolution of the Universe*, New York, Harper and Brothers Publishers, 1959.

Whitrow, G. J., *The Natural Philosophy of Time*, second edition, Oxford University Press, 1980.

- Wiener, Philip P., editor, *Leibniz Selections*, New York, Charles Scribner's Sons, 1951.
- Wigner, Eugene, "The Unreasonable Effectiveness of Mathematics in the Natural Sciences," *Communications on Pure and Applied Mathematics* XIII, 1960.
- Wilczek, Frank. "The Cosmic Asymmetry Between Matter and Antimatter," *Scientific American* 243, no. 6, 1980.
- Wilders, Peter, "Galileo to Darwin," *Christian Order*, April 1993.
- Will, Clifford, "The Confrontation Between Gravitation Theory and Experiment," *General Relativity: An Einstein Centenary Survey*, editor, Stephen W. Hawking, Cambridge University Press, 1979.
- Will, Clifford M, *Was Einstein Right? Putting Relativity to the Test*, New York, Basic Books, Inc., Publishers, 1986.
- Williams, G. E., "Geological constraints on the Precambrian history of the Earth's rotation and the Moon's orbit," *Reviews of Geophysics* 38(1): 37-59, February, 2000.
- Wilson, H. A., *Philosophical Transactions of the Royal Society*, London 204:121, 1904.
- Winkler, G. M. R., and R. G. Hall, D. B. Percival, *Meteorologia* 6, No. 4, 126-134, 1970.
- Wolf, C., "Polarization Rotation Over Cosmological Distances as a Probe to New Physics," *Aperion*, Vol. 8, No. 3, July 2001.
- Wood, A. B., and G. A. Tomlinson, L. Essen, "The Effect of the Fitzgerald-Lorentz Contraction on the Frequency of Longitudinal Vibration of a Rod," *Proceedings of the Royal Society*, 158, 6061, 1937.
- Woolsey, S. E., "Gamma-Ray Bursts: What Are They?" in *Seventeenth Texas Symposium on Relativistic Astrophysics and Cosmology*, New York Academy of Sciences, 1995.
- Wouk, Herman, *The Winds of War*, Pocket Edition, 1973.
- Wright, Karen, *Discover*, contributing editor, "The Master's Mistakes," September 2004.
- Yates, Frances, A., *Giordano Bruno and the Hermetic Tradition*, University of Chicago Press, 1964, 1991.
- Yilmaz, H., "Towards a Field Theory of Gravitation," *Il Nuovo Cimento*, Vol. 107B, no. 8, 1991.
- Young, Thomas, "Experiments and Calculations Relative to Physical Optics," 1803 Bakerian Lecture, *Philosophical Transactions of the Royal Society of London* 94, 1-16.
- Yourgrau, Palle, *A World Without Time: The Forgotten Legacy of Gödel and Einstein*, Perseus Book Groups, 2006.
- Zackheim, Michele, *Einstein's Daughter: The Search for Lieserl*, New York, Riverhead Books, 1999.

Zhuck, N. A., "Cosmological Effects in Bulky Michelson-Morley Interferometers," Ukrainian-Russian conference, Nov. 8-11, 2000.

Zhuck, N. A., *Spacetime and Substance* 1:1, 29-34, 2000.

Zhuck, N. A., *Spacetime and Substance* 1:5, 71-77, 2000.

Zhuck, N. A. "The Microwave Background Radiation as aggregate radiation of all stars," XVII International Conference April 12-14, 2000.

Zhuck, N. A., and V. V. Moroz, A. A. Varaksin, "Quasars and the Large Scale Structure of the Universe," *Spacetime and Substance, International Physical Journal*, Ukraine, Vol. 2, No. 5 (10), 2001.

Zimmermann, J. E. and J. E. Mercerau, *Physical Review Letters*, 14, 887 (1965).

Zinner, Ernst, *Entstehung und Ausbreitung der Copernicanischen Lehre* (Erlangen, 1943).

Zirker, J. B., *Total Eclipses of the Sun*, Princeton University Press, 1995.

Zoffoli, Enrico, *Cristianesimo: corso di teologia cattolica*, Udine: Edizioni Segno, 1994.

Zurhellen, Observations of binary stars: $k < 10^{-6}$, *Astr. Nachr.* 198 (1914), p 1.

Zwicky, Fritz, "Redshift of Spectral Lines," *Proceedings of the National Academy of Sciences*, 15, 773, 1929.

GWW Chap 12 Webliography

General References

Wikipedia: <http://en.wikipedia.org/wiki/>

Hyperphysics: <http://hyperphysics.phy-astr.gsu.edu/hbase/hph.html>

Geocentrism

Geocentrism: forever on the scaffold:

<http://users.rcn.com/robert.bennett/GeocentrismRJBv2.doc>

Word IQ: <http://www.wordiq.com/definition/Geocentrism>

The non-moving Earth: <http://www.fixedearth.com/>

Geocentrism: <http://users2.ev1.net/%7Eorigins/menu-helio.htm>

De Labore Solis: <http://users2.ev1.net/%7Eorigins/pdf/vdkbook.pdf>

Association for Biblical Astronomy: <http://www.geocentricity.com/>

Geocentrism Bible:

<http://www.angelfire.com/journal/PhilsvIEWS/Problems/Geocentrism.html>

Modern Geocentrism Encyclopedia:

http://www.createdbygod.com/encyclopedia/Modern_geocentrism/

David Rice: <http://www.skepticfiles.org/misc3/geosync.htm>

Introduction to Geocentrism: <http://www.geocentric-universe.com/page78.htm>

The Whys and Wherefores of Geocentrism: Part II:

http://www.geocentricity.com/bibastron/ts_history/history2.html

The Heliocentric Hoax: <http://hometown.aol.com/lapidesclamabunt/hoax.htm>

Geocentrism: <http://www.glasglow.com/evolution/index.php/Geocentrism>

Geocentrism - Geostationism: <http://www.refcm.org/RICDiscussions/Science-Scripture/geocentricity.htm>

The Scriptural Basis for a Geocentric Cosmology:

<http://hypertextbook.com/eworld/geocentric.shtml>

Mach's principle

Library of Halexandria: <http://www.halexandria.org/dward146.htm>

20th Century Concepts in STM:

<http://www.physics.nyu.edu/courses/V85.0020/node24.html>

John K. Harms: <http://www.johnkharms.com/reference.htm>

Encyclopedia.com: <http://www.encyclopedia.com/html/M/Machspri.asp>

Criticism of the Foundations of the Relativity Theory:

<http://www.antidogma.ru/english/node30.html>

Ether

Modern Scientific Theories of the ancient Aether:

<http://www.mountainman.com.au/aetherqr.htm>

Definition of Aether: <http://www.wordiq.com/definition/Aether>

Subquantum Physics and Aether Theories:

<http://www.rialian.com/rnboyd/subquantum.htm>

Physics: <http://www.esotericscience.com/Physics.aspx>

The Aether, Yes or No: <http://www.lldolphin.org/aether.html>

Aether Sites: http://www.aethro-kinematics.com/wc_sites.html

The New Science of Massfree Energy (or Aether):
<http://www.massfree.com/Science.html>

Relativity

Relativity -The Special and General Theory: <http://www.bartleby.com/173/>
 Relativity Tutorial – Galilean/Special/General:
<http://www.astro.ucla.edu/~wright/relatvty.htm>

Special Relativity: <http://www2.slac.stanford.edu/vvc/theory/relativity.html>

Relativity on the World Wide Web: <http://math.ucr.edu/home/baez/relativity.html>

General relativity:
http://www-groups.dcs.st-and.ac.uk/~history/HistTopics/General_relativity.html

Reflections on Relativity: <http://www.mathpages.com/rr/rrtoc.htm>

Relativity dissent

Anti-relativity: <http://www.anti-relativity.com/>

The Ether Gauge Theory: <http://egtphysics.net/Index.htm>

The Michelson and Morley 1887 Experiment and the Discovery of Absolute Motion:
http://www.scieng.flinders.edu.au/cpes/people/cahill_r/CahillMM.pdf

Wisp Unification Theory: <http://www.kevin.harkess.btinternet.co.uk/>

The Great Error of Physics: <http://www.tsolkas.gr/english/english.html>

Book, Publications, Papers, and Writings of Ken H. Seto:
<http://my.erinet.com/~kenseto/>

Relativity Theory: <http://renshaw.teleinc.com/>

Aethro-kinematics: <http://www.aethro-kinematics.com/>

Crank dot net: <http://www.crank.net/relativity.html>

Parallax

Parallax: <http://www.ast.cam.ac.uk/~mjp/parallax.html>

Web Simulations: <http://instruct1.cit.cornell.edu/courses/astro101/java/simulations.htm>
 Stellar Parallaxes:
http://www.astro.washington.edu/labs/parallax/stellar_parallaxes.html

Trigonometric Parallax: <http://www.astro.ucla.edu/~wright/distance.htm>

Stellar aberration: Three traps in stellar aberration:
<http://www.aip.de/~lie/PUBLICATIONS/ThreeTraps.html>

Apparent Lack of Symmetry in Stellar Aberration :
<http://www.rajandogra.freesevers.com/>

Stellar Aberration and Einstein's Relativity:
<http://www.newtonphysics.on.ca/Aberration/Aberration.html>

Bradley's Discovery of Stellar Aberration:
<http://www.cseligman.com/text/history/bradley.htm>

The stellar aberration of the star γ -Draconis with ether: <http://www.paradox-paradigm.nl/The%20stellar%20aberration%20of%20the%20star%20y-Draconis.htm>

Stellar Aberration:
<http://www.globalseve.net/~bumblebee/geocentrism/aberration.html>

Stellar Aberration: <http://www.anti-relativity.com/stellaraberration.htm>

Occam's Razor

Relativity FAQ: <http://www.weburbia.com/physics/occam.html>

Occam's Razor: http://www.2think.org/occams_razor.shtml

Foucault Pendulum

Foucault Pendulum: <http://www.si.edu/resource/faq/nmah/pendulum.htm>

Foucault Pendulum:
http://www.phys.unsw.edu.au/PHYSICS_!/FOUCAULT_PENDULUM/foucault_pendulum.html

Foucault pendulum - the physics (and maths) involved:
<http://www.phys.unsw.edu.au/~jw/pendulumdetails.html>

Sagnac experiment

Sagnac experiment: <http://www.antidogma.ru/english/node38.html>

The Sagnac Effect: <http://www.ldolphin.org/sagnac.html>

Sagnac interferometer: http://www.physik.fu-erlin.de/~bauer/habil_online/node11.html

Sagnac Effect: <http://www.egtphysics.net/Sagnac.htm>

Experimental Tests Invalidating Einstein's Relativity:
<http://www.newtonphysics.on.ca/faq/invalidation.html>

Michelson-Gale-Pearson

Michelson-Gale Experiment: <http://renshaw.teleinc.com/papers/fizeau2/fizeau2.stm>

The Tribulations of Relativity with respect to Rotation:
<http://aetherometry.com/publications/direct/AS4-02.pdf>

Ives-Stilwell

Ives-Stilwell Experiment: <http://www.wbabin.net/physics/faraj7.htm>

High Speed Reenactments of the Ives-Stilwell Experiment:
<http://www.wbabin.net/sfarti/sfarti15.pdf>

Experimental Test Theories for STR: Part 1, The Ives-Stilwell Experiment:
http://www.mrelativity.net/Papers/29/ExperimentalTestsIforSTR_IS_1.pdf

Hefele-Keating

Hefele & Keating Tests; Did They Prove Anything?: <http://www.anti-relativity.com/Hefelekeatingdebunk.htm>

A New Interpretation of the Hefele-Keating Experiment: <http://www.physical-congress.spb.ru/english/spenser1/spencer1.asp>

Discussion: Hefele-Keating:
http://omniknow.com/common/wiki.php?in=en&term=Hefele-Keating_experiment

GPS

Relativity and GPS: <http://egtphysics.net/GPS/RelGPS.htm>

Real-World Relativity: The GPS Navigation System: <http://www-astronomy.mps.ohio-state.edu/~pogge/Ast162/Unit5/gps.html>

GPS and Relativity: <http://www.physicsmyths.org.uk/gps.htm>

What GPS Tells Us about the Twin's Paradox:
<http://www.metaresearch.org/cosmology/gravity/gps-twins.asp>

GPS and the Constant Velocity of Light:
<http://www.newtonphysics.on.ca/Illusion/index.html>

Atmospheric Circulation

Atmospheric Circulation:
<http://ess.geology.ufl.edu/ess/Notes/AtmosphericCirculation/atmosphere.html>

General Circulation of the Atmosphere:
http://www.uea.ac.uk/~e930/e174/17_atmc.html

Atmospheric circulation: <http://www.nationmaster.com/encyclopedia/Atmospheric-circulation>

Global Energy Balance:
http://geography.uoregon.edu/envchange/clim_animations/index.html

Galileo: Jovian moons

Galileo: the Telescope and the Laws of Dynamics: http://www.astro-tom.com/biographies/galileo_galilei.htm

The Jovian System: <http://www2.jpl.nasa.gov/galileo/Jovian.html>

Galileo : Venus phases

Images: Phases of Venus:

<http://www.calvin.edu/academic/phys/observatory/images/venus/venus.html>

How and Why Venus Changes Phases:

http://www.space.com/spacewatch/venus_phases_031128.html

Galileo: Tidal flow

The theory of tides: <http://www.pd.astro.it/E-MOSTRA/NEW/A1002OSS.HTM>

The Moon and the Tides: <http://mikeschuler.web.aplus.net/id14.html>

Galileo's Scientific Story: <http://plato.stanford.edu/entries/galileo/#3>

Aberration – All types

Aberration of Starlight: <http://www.phy6.org/stargaze/Saberr.htm>

Aberration of Starlight without Relativistic Consideration:

<http://zyx.org/ABERRATION.html>

The Bradley-Type Experiments: <http://www.setterfield.org/cx2.html>

Changes of Celestial Coordinates:

http://www.seds.org/~spider/spider/ScholarX/coord_ch.html#aberration

Did Bradley make a mistake in determining the course of diurnal aberration?:

<http://users.net.yu/~mrp/chapter22.html>

Basic Doubts on Relativity: <http://www.geocities.co.jp/Technopolis/2561/eng.html>

Double Star Images: <http://hyperphysics.phy-astr.gsu.edu/hbase/relativ/star.html>

A Dissident View of Relativity Theory: <http://www.infinite-energy.com/iemagazine/issue59/adissidentview.html>

Stellar and Planetary Aberration:

<http://redshift.vif.com/JournalFiles/Pre2001/V00NO19PDF/NR19PHI.PDF>

Topocentric (astronomic) coordinates of planets:

<http://levante.org/svarogich/en/memo05.html>

Lunar Laser Ranging Experiments:

<http://pages.sbcglobal.net/webster.kehr/Chapters/Chapter100-LLR.htm>

Aberration and Ether: <http://free-energy.webpark.cz/teorie/detection/chapter-14.htm>

WESTPAC Satellite. Scientific-Technical Note:
http://www.dgfi.badw-muenchen.de/edc/ilrs/ilrs.gsfc.nasa.gov/docs/Westpac_final.pdf

Retroreflector Array Transfer Functions:
<http://nercslr.nerc-monkswood.ac.uk/sig/Transfer.pdf>

New moon: http://www.serebella.com/encyclopedia/article-New_moon.html

Classical Aberration: <http://www.fourmilab.ch/cship/aberration.html>

The PROBA Satellite Star Tracker Performance:
<http://www.iaonet.org/symp/berlin/IAA-B4-0803.pdf>

Aberration of light: <http://brandt.kurowski.net/projects/lisa/wiki/view.cgi?doc=563>

Fresnel Drag

Light and the Aether: <http://www.energyscience.org.uk/tu/tu05.htm>

The drag coefficient of Fresnel: <http://www.paradox-paradigm.nl/The%20drag%20coefficient%20of%20Fresnel.htm>

Fresnel's Coefficient of Aether Drag:
<http://renshaw.teleinc.com/papers/fizeau/fizeau.stm>

Propagation of Light in Moving Bodies:
<http://home.att.net/~numericana/answer/relativity.htm#fizeau>

Stokes

19th Century Ether Theory: <http://www.tc.umn.edu/~janss011/pdf%20files/ether.pdf>

Luminiferous aether:
http://www.nebulasearch.com/encyclopedia/article/Luminiferous_aether.html

Requiem for Relativity: <http://www.relativitycollapse.net/ether.html>

Faraday Rotor Generator

Faraday generator rotor current field: <http://www.stardrivedevice.com/rotor-field.html>

Homopolar Generator Experiments: <http://amasci.com/freenrg/n-mach.html>

Stardrive Generator: http://www.stardrivedevice.com/power_plant.html

Notes on the Faraday Disc:
<http://depalma.pair.com/Absurdity/Absurdity08/FaradayDisc.html>

Fizeau

The Experiment of Fizeau: <http://www.paradox-paradigm.nl/The%20experiment%20of%20Fizeau.htm>

The Experiment of Fizeau: <http://renshaw.teleinc.com/papers/fizeau4b/fizeau4b.stm>

The Experiment of Fizeau: <http://renshaw.teleinc.com/papers/ph97fi1/ph97fi1.stm>

Hoek

Petr Beckmann:

<http://redshift.vif.com/JournalFiles/Pre2001/V00NO18PDF/NR18ISS.PDF>

The Whys and Wherefores of Geocentrism: Part III:

http://www.geocentricity.com/bibastron/ts_history/history3.html

Airy

Are the laws of "Classical Physics" true?: <http://www.csama.org/200001NL.htm>

Airy's experiment:

<http://www.public.iastate.edu/~edsall/physics/hep/relativity/Notes/book/node137.html>

Sir George Airy Water-Telescope Experiment:

<http://www.teslaphysics.com/Chapters/Chapter140-AberrationAndEther.htm>

Michelson-Morley

Michelson-Morley Expt.: <http://physics.bgsu.edu/~stoner/P202/relative1/sld008.htm>

The Overlooked Phenomena in the Michelson-Morley Experiment:

<http://www.newtonphysics.on.ca/michelson/michelson.html>

New look on Michelson and Morley 1887 experiment:

http://www.ontostat.com/anglais/interferometer_gb.htm

The Michelson-Morley Experiment:

http://www.drphysics.com/syllabus/M_M/M_M.html

The Michelson-Morley Experiment: <http://www.aquestionoftime.com/michmore.htm>

Crucial Tests?:The Michelson-Morley Experiment:

<http://www1.umn.edu/ships/updates/m-morley.htm>

Oliver Lodge

History: <http://maxwell.byu.edu/~spencerr/phys442/node4.html>

Trouton-Noble

Lecture No. 21: <http://www.energyscience.org.uk/le/le21.htm>

Induction and Relativity: http://www.electrogravityphysics.com/html/sec_1.html

Experiment: <http://trouton-noble-experiment.-neil-schulman.brainsip.com/>

Trouton-Rankine

Trouton Rankine Experiment and the End of the FitzGerald Contraction:
http://www.mrelativity.net/Papers/29/Trouton_Rankine.pdf

Zurhellen

Questions about the Speed of Light: <http://www.wbabin.net/physics/traill.htm>

Kennedy-Thorndike

High precision tests of Special and General Relativity: <http://www.exphy.uni-duesseldorf.de/ResearchInst/FundPhys.html>

Kennedy-Thorndike experiment: http://www.serebella.com/encyclopedia/article-Kennedy-Thorndike_experiment.html

Townes

The experiment of J.P. Cedarholm and C.H. Townes in 1958:
<http://pages.sbcglobal.net/webster.kehr/DeWitte/cedarh.htm>

Brecher

Depalma- spinning ball drop: Gravity & The Spinning Ball Experiment:
<http://www.rexresearch.com/depalma/depalma.htm#2>

Understanding the Dropping of the Spinning Ball Experiment:
<http://www.rexresearch.com/depalma/depalma.htm#3>

Gyro Drop

Gyro Drop Experiment: <http://depalma.pair.com/gyrodrop.html>

Tift Quantum red shifts

Red Shift Riddles: <http://www.cs.unc.edu/%7Eplaisted/ce/redshift.html>

Our galaxy is the centre of the universe, quantized red shifts show:
http://www.answersingenesis.org/home/area/magazines/tj/docs/TJv16n2_CENTRE.pdf

Atomic Quantum States, Light and the Redshift
[:http://www.setterfield.org/quantumredshift.htm](http://www.setterfield.org/quantumredshift.htm)

Redshift Energy Values and Aetheric Density Levels:
<http://ascension2000.com/DivineCosmos/08.htm>

Red shift anomaly

The Vacuum, Light Speed and the Redshift:
<http://www.ldolphin.org/setterfield/vacuum.html>

Cosmic Megawalls

Cosmic Megawalls: <http://www.science-frontiers.com/sf069/sf069a03.htm>

What are topological defects?: http://www.damtp.cam.ac.uk/user/gr/public/cs_top.html

What are domain walls and (cosmic) textures?:
<http://www.madsci.org/posts/archives/jul2000/963999791.As.r.html>

Mirabel and Rodriguez

A Superluminal Source in the Galaxy:
<http://www.nature.com/nature/journal/v371/n6492/abs/371046a0.html;jsessionid=C3998AB0A030AD44CED7FA626074B13A>

HEAD AAS Rossi Prize Winners: <http://www.aas.org/head/rossi/rossi.recip.html#L>

Binary Star Precession

Precession of the Binary Star Di Herculis :
<http://www.autodynamicsuk.org/DI%20Herculis.htm>

General Relativity or Newtonian Tidal Effects ?:
http://www.gsanctuary.com/general_relativity.html

Perihelion Advance: <http://www.autodynamicsuk.org/PerihelionAdvance.htm>

Universal Gravitation: <http://www.autodynamicsuk.org/Universal%20Gravitation7.htm>

Aspden Effect

Re-emergence of the Aether: <http://www.esotericscience.com/Aether.aspx>

The Aspden Effect: <http://ascension2000.com/ConvergenceIII/c03-aether.htm>

Marinov Plasma Tube

The Self Accelerating Plasma Tube: <http://amasci.com/freenrg/sap.txt>

Casimir Effect

The Casimir effect: a force from nothing: <http://physicsweb.org/articles/world/15/9/6>

The Energetic Vacuum: <http://www.ldolphin.org/energetic.html>

Experiment could reveal extra dimensions, exotic forces:
http://www.eurekalert.org/pub_releases/2002-10/pu-ecr102902.php

Casimir Effect: <http://www.halexandria.org/dward152.htm>

Casimir Force: <http://www.du.edu/~jcalvert/phys/casimir.htm>

Roth Magnetic Memory

5.9 Donald Roth and Magnetic Memory:

<http://ascension2000.com/ConvergenceIII/c305.htm>

The First Aether Conference: http://www.padrak.com/ine/NEN_5_4_1.html

Latent Forces in the Vacuum and in Matter:

<http://www.timstouse.com/EarthChanges/DivineCosmos/chapter1.htm>

Magnetic Memory: <http://ascension2000.com/ConvergenceIII/c03-aether.htm>

Super-luminality

Superluminal Light-A Scientific Revolution in Progress:

<http://www.wbabin.net/science/faraj8.htm>

Clear message for causality: <http://www.jefallbright.net/node/1744>

Holger Muller

Testing the Fundamental of Physics Using Cryogenic Microwave Oscillators:

<http://www.fsm.pd.uwa.edu.au/sol.html>

Quasars in galaxies

Quasars as Ejection Phenomena, and the Redshift Controversy:

<http://www.livingcosmos.com/quasar.htm>

Alternate Approaches and the Redshift Controversy:

<http://www.astr.ua.edu/keel/galaxies/arp.html>

Book Review: Seeing Red by Halton Arp:

<http://www.metaresearch.org/publications/books/SeeingRed-Arp.asp>

Quasars – Three Years Later: <http://www.reciprocalssystem.com/ce/q3y.htm>

Observing the Arp Peculiar Galaxies: <http://www.deep-sky.co.uk/galaxies/arp/arp.htm>

Redshift survey surprises

The CfA Redshift Survey: <http://cfa-www.harvard.edu/~huchra/zcat/>

Main Unsolvable Difficulties of the Big Bang Model.:

<http://www.newtonphysics.on.ca/QUASARS/Quasars.html>

The Great Wall: <http://csep10.phys.utk.edu/astr162/lect/gclusters/gwall.html>

The Great Attractor: <http://www.solstation.com/x-objects/greatatt.htm>

The Fingers Of God Point To No Big Bang:

<http://www.rense.com/general58/bbang.htm>

Fingers of God: <http://www.thunderbolts.info/tpod/2004/arch/041018fingers-god.htm>

Redshift-space Distortions: <http://astron.berkeley.edu/~louis/astro228/redshift.html>

Gamma ray bursts

Gamma ray bursts: <http://imagine.gsfc.nasa.gov/docs/introduction/bursts.html>

Gamma ray bursts: http://imagine.gsfc.nasa.gov/docs/science/know_11/bursts.html

BATSE: Burst and Transient Source Experiment: <http://www.batse.com/>

Gamma-rays: <http://imagers.gsfc.nasa.gov/ems/gamma.html>

Gamma-Ray Burst Afterglows: <http://www.aip.de/~jcg/grb.html>

Gravitomagnetic London Moment

Towards A New Test Of General Relativity:

http://www.spacedaily.com/reports/Towards_A_New_Test_Of_General_Relativity.html
1

In Search of Gravitomagnetism:

http://science.nasa.gov/headlines/y2004/19apr_gravitomagnetism.htm

Anti-gravity Effect? Gravitational Equivalent of a Magnetic Field Measured In Lab:

<http://www.sciencedaily.com/releases/2006/03/060325232140.htm>

Moving Gravity Field Measured in Lab: <http://technocrat.net/d/2006/3/23/1556>

Gravitomagnetic London Moment?: <http://dabacon.org/pontiff/?m=200603>

Dayton Miller

Dayton Miller's Ether-Drift Experiments: A Fresh Look:

<http://www.orgonelab.org/miller.htm>

Dayton Miller's Interferometer Experiments: <http://www.anti-relativity.com/daytonmiller.htm>

<http://www.anti-relativity.com/daytonmiller.htm>

The Michelson-Morley Experiment: <http://www.anti-relativity.com/mmx.htm>

The Experiments of Dayton Miller (1925-26) and the Theory of Relativity:

<http://allais.maurice.free.fr/English/media12-1.htm>

The Fundamental and Complete Collapse of Relativity Theory:

<http://allais.maurice.free.fr/English/yellow01.htm>

A Note on Dayton Miller's Supposed Discovery of an Aether Drift:

<http://www.aetherometry.com/miller.html>

Illingworth

Michelson-Morley Experiments Revisited: Systematic Errors, Consistency Among Different Experiments, and Compatibility with Absolute Space:
<http://redshift.vif.com/JournalFiles/Pre2001/V05NO1PDF/V05N1MUN.pdf>

Michelson-Morley's Experiments Revisited and the CMB Preferred Frame:
http://www.scieng.flinders.edu.au/cpes/people/cahill_r/HPS9.pdf

Pound-Rebka

GTR Tests – The Pound-Rebka- Snider Experiment:
http://www.mrelativity.net/Papers/29/GTR_Tests_Pound_Rebka.pdf

Pound-Rebka experiment: http://www.1-generator.com/articles/Pound-Rebka_experiment

Introduction to General Relativity:
<http://www.physics.fsu.edu/Courses/Spring98/AST3033/Relativity/GeneralRelativity.htm>

Jaseja

The experiment of T.S. Jaseja et al. in 1964.:
<http://pages.sbcglobal.net/webster.kehr/DeWitte/jaseja.htm>

Spinning Mossbauer Disc - Champeny

Experimental disproof of the theory of Relativity: <http://www.physics-talk.com/Experimental-disproof-of-the-theory-of-Relativity-6099365.html>

In Search of an Ether Drift: <http://www.egtphysics.net/ron1/etherdrift.htm>

Symmetry or Simultaneity: <http://www.egtphysics.net/Ron1/Symmetry.htm>

Turner – Hill

Clock Behavior and the Search for Underlying Mechanism for Relativistic Phenomena:
<http://www.aliceinphysics.com/introduce/clock.pdf>

Shamir and Fox

Searching for Earth's Trajectory in the Cosmos:
<http://redshift.vif.com/JournalFiles/V09NO4PDF/V09N4NAS.pdf>

Main Mistake of Michelson: <http://bourabai.georisk.kz/petrov/mistake-e.htm>

On the Trail of Fresnel's Search for an Ether Wind:
<http://redshift.vif.com/JournalFiles/Pre2001/V05NO3PDF/v05n3nas.pdf>

Shapiro - Venus radar

Light Lunacy: http://surf.de.uu.net/bookland/sci/farce/farce_6.html

Suppression of Inconvenient Facts in Physics:
<http://www.suppressedscience.net/physics.html>

Relativistic Deflection of Light Near the Sun Using Radio Signals and Visible Light:
<http://www.newtonphysics.on.ca/ECLIPSE/Eclipse.html>

Brillet - Hall

Collapse of SRT 2: Earth Carries Along Electric and Magnetic Fields:
http://mywebpages.comcast.net/adring/Hajra_part_2_ckw.pdf

Design Error in the Brillet and Hall's Experiment:
<http://www.newtonphysics.on.ca/brillet-hall/index.html>

Stasis Field Theory I: <http://users.powernet.co.uk/bearsoft/StFTi.html>

Brillet and Hall experiment and Klauber's challenge:
http://freeweb.supereva.com/solciclos/weber_c_3.pdf

Torr Kolen

One-way Speed of Light Measurement: <http://www.aspdn.org/books/Poc/IIIb.html>

The Torr-Kolen Experiment 1981:
http://www.scieng.flinders.edu.au/cpes/people/cahill_r/HPS16.pdf

Throbbing Earth

The Throbbing Earth: <http://www.science-frontiers.com/sf030/sf030p11.htm>

Silvertooth

Galactic Drift: <http://www.infinite-energy.com/iemagazine/issue59/adissidentview.html>

Standing Wave Interferometry: <http://www.aspdn.org/papers/bib/1990a.htm>

DeWitte

The DeWitte Experiment is clear proof that the ether exists:
<http://www.kevin.harkess.btinternet.co.uk/feedback/feedback.html>

My Experiment of Detection of the Ether-wind:
<http://www.teslaphysics.com/DeWitte/belgacom.htm>

Experiment 4, Positive Result: <http://www.teslaphysics.com/DeWitte/exp4.htm>

GTWMC Transformations: <http://www.teslaphysics.com/DeWitte/gtwmc.htm>

The De Witte Effect: <http://www.teslaphysics.com/Chapters/Chapter160-DeWitte.htm>

CMB dipole

U2 Anisotropy Experiment: <http://aether.lbl.gov/www/projects/u2/>

The CMB- A Relic from the Origin of the Universe:
<http://www.oarval.org/COBEen.htm>

Absolute Motion and Quantum Gravity:
http://www.mountainman.com.au/process_physics/HPS11.pdf

2.2. Cosmic Microwave Background Overview:
<http://www.science.doe.gov/hep/SAGENAPFINAL.pdf>

Models of Structure Formation in the Early Universe:
http://www.physics.ucsb.edu/~jatila/astro/astro2/cobe_lab.html

NASA's Legacy Archive for Microwave Background Data Analysis (LAMBDA):
<http://lambda.gsfc.nasa.gov/>

Nodland and Ralston

Indication of Anisotropy in Electromagnetic Propagation over Cosmological Distances:
http://arxiv.org/PS_cache/astro-ph/pdf/9704/9704196.pdf

Putting the Universe in Order: <http://www.exn.ca/Stories/1997/04/18/04.asp>
 Unequal space provides twist to Big Bang theory:
<http://www.telegraph.co.uk/htmlContent.jhtml?html=/archive/1997/04/18/nbang18.html>

Axis gives universe orientation: <http://www.spie.org/web/oer/june/jun97/axis.html>

Cosmic Axis Threatens Big Bang:
http://www.creationresearch.org/creation_matters/97/cm9705.html#Cosmic_Axis

Polarized Space - Is the Universe Rotating?:
<http://www.polarization.com/space/space.html>

The relevance of directions in the cosmos:
<http://www.cc.rochester.edu/college/rtc/Borge/analysis.html>

CMB quadrupole

A CMB Polarization Primer:
<http://background.uchicago.edu/%7Ewhu/polar/webversion/polarpage.html>

The Physics of Microwave Background Anisotropies: <http://background.uchicago.edu/>

Ned Wright's Cosmology Tutorial: http://www.astro.ucla.edu/~wright/cosmo_01.htm

CMB Polarization: <http://space.mit.edu/home/angelica/polarization.html>

Multipole Vectors: <http://www.phys.cwru.edu/projects/mpvectors/>

Map reveals strange cosmos: <http://www.whyevolution.com/strange.html>

Galaev

Aether-Drift Velocity and Kinematic Ether Viscosity within Optical Wave Bands:
<http://www.spacetime.narod.ru/0015-pdf.zip>

The Measuring of Ether-Drift Velocity and Kinematic Ether Viscosity within Optical Wave Bands: <http://home.t01.itscom.net/allais/blackprior/galaev/galaev-2.pdf>

Ether-drift Experiment in the band of radio wave: Yuri M.Galaev, Petit, Zhukovsky, 2000. (Russian).

What is Wrong with Relativity?: <http://www.esotericscience.com/Relativity.aspx>

Pioneer 10,11 anomaly

Indication, from Pioneer 10/11, Galileo, and Ulysses Data, of an Apparent Anomalous, Weak, Long-Range Acceleration+: http://arxiv.org/PS_cache/gr-qc/pdf/9808/9808081.pdf

Pioneer 10 AND 11 Acceleration Anomaly: <http://www.setterfield.org/accelanom.htm>

Anomalous Acceleration of Pioneer 10 and 11:
<http://www.newtonphysics.on.ca/Anomalous/Acceleration.html>

A Mission to Test the Pioneer Anomaly: http://www.arxiv.org/PS_cache/gr-qc/pdf/0205/0205059.pdf

Using Early Data to Illuminate the Pioneer Anomaly: http://arxiv.org/PS_cache/gr-qc/pdf/0507/0507052.pdf

Conventional Forces can Explain the Anomalous Acceleration of Pioneer 10:
http://www.arxiv.org/PS_cache/gr-qc/pdf/0107/0107092.pdf

Study of the anomalous acceleration of Pioneer 10 and 11:
http://arxiv.org/PS_cache/gr-qc/pdf/0104/0104064.pdf

ESA to look for the missing link in gravity:
<http://spaceflightnow.com/news/n0209/12gravity/>

Pioneer Space Probes Unexpectedly Slow Down In Deep Space:
<http://www.technovelgy.com/ct/Science-Fiction-News.asp?NewsNum=270>

Pioneer Anomaly: <http://home.earthlink.net/~chkington/PioneerAnomaly.htm>